



- (51) **International Patent Classification:**
D07B 5/00 (2006.01) D07B 1/02 (2006.01)
- (21) **International Application Number:**
PCT/EP2012/076005
- (22) **International Filing Date:**
18 December 2012 (18.12.2012)
- (25) **Filing Language:** English
- (26) **Publication Language:** English
- (30) **Priority Data:**
11194279.3 19 December 2011 (19.12.2011) EP
- (71) **Applicant:** DSM IP ASSETS B.V. [NL/NL]; Het Overloon 1, NL-6411 TE Heerlen (NL).
- (72) **Inventors:** DARDA, Kishor; c/oDSM Dyneema, 4th Floor, Windsor House, CST Road, Kalina, Santacruz East, Mumbai 400098 (IN). BOSMAN, Rigobert; P.O. Box 4, NL-6100 AA Echt (NL). DIRKS, Christiaan Henri Peter; P.O. Box 4, NL-6100 AA Echt (NL).
- (74) **Agent:** MORARIU-RADU, Mihai Dorin; P.O. Box 4, NL-6100 AA Echt (NL).
- (81) **Designated States** (unless otherwise indicated, for every kind of national protection available): AE, AG, AL, AM, AO, AT, AU, AZ, BA, BB, BG, BH, BN, BR, BW, BY, BZ, CA, CH, CL, CN, CO, CR, CU, CZ, DE, DK, DM, DO, DZ, EC, EE, EG, ES, FI, GB, GD, GE, GH, GM, GT, HN, HR, HU, ID, IL, IN, IS, JP, KE, KG, KM, KN, KP, KR, KZ, LA, LC, LK, LR, LS, LT, LU, LY, MA, MD, ME, MG, MK, MN, MW, MX, MY, MZ, NA, NG, NI,

[Continued on nextpage]

(54) **Title:** ROPE COMPRISING AT LEAST ONE FIBRILLATED FILM TAPE

(57) **Abstract:** A process for producing a high strength rope comprising the step of i) providing a uniaxially oriented tape (10) comprising ultra-high molecular weight polyethylene, the tape (10) having a tensile strength of at least 0.9 GPa, and ii) simultaneously twisting and fibrillating the tape (10) into a twisted strand of fibrillated tape with a coherent network of filaments and fibrils. A rope obtainable by the process and products comprising the rope are also disclosed.

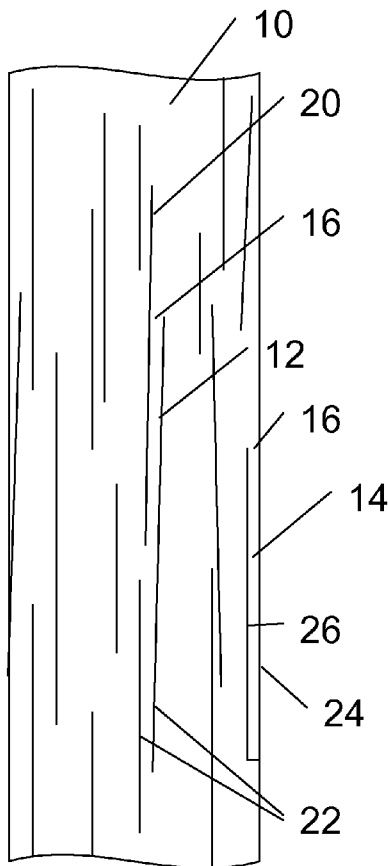

Figure 1

NO, NZ, OM, PA, PE, PG, PH, PL, PT, QA, RO, RS,
RU, RW, SC, SD, SE, SG, SK, SL, SM, ST, SV, SY, TH,
TJ, TM, TN, TR, TT, TZ, UA, UG, US, UZ, VC, VN,
ZA, ZM, ZW.

LV, MC, MK, MT, NL, NO, PL, PT, RO, RS, SE, SI, SK,
SM, TR), OAPI (BF, BJ, CF, CG, CI, CM, GA, GN, GQ,
GW, ML, MR, NE, SN, TD, TG).

(84) Designated States (*unless otherwise indicated, for every kind of regional protection available*): ARIPO (BW, GH, GM, KE, LR, LS, MW, MZ, NA, RW, SD, SL, SZ, TZ, UG, ZM, ZW), Eurasian (AM, AZ, BY, KG, KZ, RU, TJ, TM), European (AL, AT, BE, BG, CH, CY, CZ, DE, DK, EE, ES, FI, FR, GB, GR, HR, HU, IE, IS, IT, LT, LU,

Published:

- *with international search report (Art. 21(3))*
- *before the expiration of the time limit for amending the claims and to be republished in the event of receipt of amendments (Rule 48.2(h))*

ROPE COMPRISING AT LEAST ONE FIBRILLATED FILM TAPE

The invention relates to a process for production of a high tensile strength rope comprising at least one strand wherein said strand comprises a uniaxially oriented elongated body comprising ultra-high molecular weight polyethylene.

Such a rope is known from US 5901632. In this patent publication a large-diameter braided rope is described, which rope contains primary strands, preferably from secondary strands containing high tensile strength uniaxially oriented ultra-high molecular weight polyethylene filaments. In the most preferred embodiments indicated, the rope is a 12-strand, two-over/two-under circular braid, wherein each strand is itself a 12-strand braid made from high-modulus polyethylene (HMPE) filaments (12x12 construction).

Such ropes, especially if produced from high tenacity fibers, will show a high resistance to longitudinal deformation even when high extensional forces are applied, making them especially suited for load bearing applications.

Nevertheless it was observed that such ropes may undergo substantial deformation when non-extensional forces are applied in other directions, such as axial compression, bending forces or a transversal or rolling force applied crosswise to its length direction. When exposed to frequent non-extensional forces, ropes may fail due to rope and filament damage resulting from e.g. external and internal abrasion, frictional heat, or fatigue. Additionally, when ropes are subjected to an excessive number of axial compressions, e.g. cycles at low tension, axial compression fatigue caused by buckling and kinking within the strands is observed. No solution other than avoiding conditions of rope cycles at low tension has been proposed to improve axial compression fatigue; see for example at p.171ff and 353 of the Handbook of fibre rope technology (eds McKenna, Hearle and O'Hear, Woodhead Publishing Ltd, ISBN 1 85573 606 3).

It is an aim of the present invention to provide a process for a rope with optimized properties with respect to above mentioned deficits.

This aim is achieved according to the invention by a process for producing a rope comprising the step of providing a uniaxially oriented ultra-high molecular weight polyethylene tape having a tensile strength of at least 0.9 GPa as measured in accordance with ISO 1184(H), and simultaneously twisting and fibrillating the tape into a twisted strand of fibrillated tape with a coherent network of filaments and fibrils.

It was surprisingly observed that the process of the invention provides ropes which may have an optimized stability against the non-extensional deformational forces.

5 The invention further relates to a rope obtainable by the process according to the invention.

The rope according to the invention can have a round cross-section, e.g. a cross-section that is about circular or one that is oblong. By oblong-cross-section is herein meant that the cross-section of the rope shows a flattened, oval, or even an almost rectangular form. Such oblong cross-section preferably has an aspect
10 ratio, i.e. the ratio of width to height of the cross-section, in the range from 1.2 to 4.0. Methods to determine the aspect ratio are known to the skilled person; an example includes measuring the outside dimensions of the rope, while keeping the rope taut, or after tightly winding an adhesive tape around it. The advantage of an oblong cross-section with said aspect ratio is that during cyclic bending where the width direction of
15 the cross section is parallel to the width direction of the sheave, less stress differences might occur between the fibres in the rope. Also for certain applications, less abrasion and frictional heat may occur, which may result in enhanced bend fatigue life. The cross-section preferably has an aspect ratio of about 1.3 - 3.0, more preferably about 1.4 - 2.0.

20 Preferably, the rope and/or the fibrillated tape in the rope are coated with a coating for improving various properties such as abrasion resistance or bending fatigue. Such coatings, which can be applied to the fibrillated tape before construction of the rope, or onto the rope after it is constructed, are known and examples include coatings comprising silicone oil, bitumen and both. Polyurethane-based coating is also
25 known, possibly mixed with silicone oil. The rope preferably contains a coating in an amount of 2.5-35 wt%, expressed as weight of coating per total weight of the rope. More preferably, the rope contains an amount of 5-15 wt% of the coating.

By rope is herein understood a long assembly of at least one strand. Strands may also comprise more than one sub-strands, commonly called secondary
30 strands. Each strand or secondary strand may comprise at least one fibrillated tape as the one used in accordance with the invention.

In a preferred embodiment, the rope of the invention comprises more than one strand comprising the fibrillated tape.

35 In a further preferred embodiment all strands of the rope of the invention comprise a fibrillated tape.

In a yet another preferred embodiment, the at least one strand of the rope of the invention comprises secondary strands, wherein the secondary strands comprise the fibrillated tape.

5 The rope according to the invention may be of various constructions, including laid, braided, plaited, parallel, with or without a core. The number of strands in the rope may also vary widely. A parallel rope may be constructed with at least a single strand. The number of strands in more complex rope constructions may be at least 3 and preferably at most 50, more preferable at most 25, to arrive at a combination of good performance and ease of manufacture.

10 In a preferred embodiment the rope according to the invention is of a braided construction. Braiding provides a robust and torque-balanced rope that retains its coherency during use. There is a variety of braid types known, each generally distinguished by the method of braiding. Suitable constructions include soutache braids, tubular braids, and flat braids. Tubular or circular braids are the most preferred
15 braids for rope applications and generally consist of two sets of strands that are intertwined, with different patterns possible. The number of strands in a tubular braid may vary widely. Especially if the number of strands is high, and/or if the strands are relatively thin, the tubular braid may have a hollow core; and the braid may collapse into an oblong shape. The number of strands in a braided rope according to the
20 invention is preferably at least 4. There is no upper limit to the number of strands, although in practice ropes will generally have no more than 48 strands. Particularly suitable are ropes of an 8- or 12-strand braided construction. Such ropes provide a favourable combination of tenacity and resistance to bend fatigue, and can be made economically on relatively simple machines.

25 The rope according to the invention can also be of a laid construction having a lay length, wherein the lay length, i.e. the length of one turn of a strand in a laid construction, or of a braided construction having a braiding period, i.e. the pitch length of the braided rope, which is in the range of from 4 to 20 times the diameter of the rope. A higher lay length or braiding period may result in a rope having higher
30 strength efficiency. Preferably, the lay length or braiding period is about 5 - 15 times the diameter of the rope, more preferably 6 -10 times the diameter of the rope.

The construction of the strands of the rope according to the invention may also be laid, braided or twisted strands.

35 In one embodiment of the invention, at least one strand is a braided rope, more preferably all strands are braided ropes. Preferably said strands are

circular braids made from an even number of secondary strands, wherein the secondary strands comprise the fibrillated tape. The number of secondary strands forming the braided rope strand is not limited, and may for example range from 4 to 32; with 8, 12 or 16 being preferred in view of available machinery for making such
5 braids.

The uniaxially oriented ultra-high molecular weight polyethylene tapes suitable to manufacture the fibrillated tape may be prepared by drawing films. Films may be prepared by feeding an ultra-high molecular weight polyethylene (UHMWPE) powder between a combination of endless belts, compression-molding the UHMWPE
10 powder at a temperature below the melting point thereof and rolling the resultant compression-molded polymer thereby forming a film. Another preferred process for the formation of films comprises feeding UHMWPE powder to an extruder, extruding a film at a temperature above the melting point thereof and drawing the extruded polymer film. If desired, prior to feeding the polymer to the extruder, the polymer may be mixed
15 with a suitable liquid organic compound, for instance to form a gel, such as is preferably the case when using ultra high molecular weight polyethylene.

Drawing, preferably uniaxial drawing, of the films to produce tapes may be carried out by means known in the art. Such means comprise extrusion stretching and tensile stretching on suitable drawing units. To attain increased
20 mechanical strength and stiffness, drawing may be carried out in multiple steps.

The tapes used in the present invention are oriented by drawing, for instance at a suitable temperature, to obtain a uniaxially oriented material. With uniaxially oriented tapes is meant in the context of this application that the tapes exhibit a preferred orientation of the polymer chains in one direction, i.e. in the direction of
25 drawing. Such tapes will exhibit anisotropic mechanical properties.

The resulting drawn tapes may be used as such in the rope production process, or they may be cut or split to a desired width. Preferably the split is carried out along the direction of drawing.

The width of the tapes is only limited by the width of the film from
30 which they are produced. The width of the tapes used to produce the ropes is preferably more than 2 mm, more preferably more than 5 mm and most preferably more than 30 mm. The areal density of said tapes can be varied over a large range, for instance between 2 and 200 g/m². Preferred areal density is between 10 and 170 g/m², more preferred between 10 and 100 g/m² and most preferred between 20 and 60 g/m².
35 Further increased stability against non-extensional deformation forces may be

achieved by tapes within the described preferred ranges.

The linear density of the strand of fibrillated tape of the invention may vary within wide ranges and may be selected depending upon the number of fibrillated tapes in the strand as well as the final linear density of the rope. The linear density is measured by determining the weight in mg of 10 meters of material and is conveniently expressed in dtex (g/10km) or denier (den, g/9km). The linear density of the fibrillated tape may depend upon the areal density of the tape, the width of the tape and the twist level of the fibrillated tape. Accordingly a reduced width of the tape used to manufacture the fibrillated tape, a reduced areal density of said tape, or a higher twist level of the fibrillated tape may provide a lower linear density of the fibrillated tape, whereas increased width of said tape, areal density of said tape or reduced twist level of the fibrillated tape may provide a higher linear density of the fibrillated tape. Preferably the linear density of the fibrillated tape of the rope in the present invention will be in the range from 400 dtex (360 den) to 200.000 dtex (180000 den). More preferably the linear density of the fibrillated tape will be in the range from 1000 dtex (900 den) to 100000 dtex (90000 den), even more preferably from 2000 dtex (1800 den) to 50000 dtex (45000 den) and most preferably from 5000 dtex (4500 den) to 20000 dtex (18000 den). Stability against non-extensional deformation forces may be further optimized by tapes with linear density within the described preferred ranges.

The tape provided to the process of the invention comprises ultra-high molecular weight polyethylene (UHMWPE). The ultra-high molecular weight polyethylene may be linear or branched, although preferably linear polyethylene is used. Linear polyethylene is herein understood to mean polyethylene with less than 1 side chain per 100 carbon atoms, and preferably with less than 1 side chain per 300 carbon atoms; a side chain or branch generally containing at least 10 carbon atoms. Side chains may suitably be measured by FTIR on a 2 mm thick compression moulded film, as mentioned in e.g. EP 0269151. The linear polyethylene may further contain up to 5 mol% of one or more other alkenes that are copolymerisable therewith, such as propene, butene, pentene, 4-methylpentene, octene. Preferably, the linear polyethylene is of high molar mass with an intrinsic viscosity (IV, as determined on solutions in decalin at 135°C) of at least 4 dl/g; more preferably of at least 8 dl/g, most preferably of at least 10 dl/g. Such polyethylene is also referred to as ultra high molecular weight polyethylene (UHMWPE). Intrinsic viscosity is a measure for molecular weight that can more easily be determined than actual molar mass parameters like M_n and M_w .

The rope according to the invention may comprise further elongated bodies such as tapes, yarns and/or filaments. Such further elongated bodies may comprise polymers selected from the group consisting of polyolefins, polyesters, polyvinyl alcohols, polyacrylonitriles, polyamides, especially poly(p-phenylene teraphthalamide), liquid crystalline polymers and ladder-like polymers, such as
5 polybenzimidazole or polybenzoxazole, especially poly(1,4-phenylene-2,6-benzobisoxazole), or poly(2,6-diimidazo[4,5-b-4',5'-e]pyridinylene-1,4-(2,5-dihydroxy)phenylene). Preferably the further elongated bodies comprise UHMWPE according to the one of the tapes used in the present invention.

10 The tensile strength of the tapes prior to the fibrillation process depends on the UHMWPE from which they are produced, and on their (uniaxial) stretch ratio. The tensile strength of said tapes is at least 0.9 GPa, preferably at least 1.2 GPa, more preferably at least 1.5 GPa, even more preferably at least 1.8 GPa, and even more preferably at least 2.1 GPa, and most preferably at least 3 GPa.

15 The rope according to the invention is particularly useful in various applications such as mooring, towing, lifting, offshore installation.

It was also observed that the ropes according to the invention are also suitable for use in other applications like for example fishing lines, fishing nets, cargo nets, cargo curtains, belts, woven fabrics, raschels and slings. Therefore, the invention
20 also relates to the applications enumerated above containing the ropes of the invention.

One embodiment of the invention relates to a process for the production of a rope comprising the step of providing an uniaxially oriented tape comprising ultra-high molecular weight polyethylene having a tensile strength of at
25 least 0.9 GPa as measured in accordance with ISO 1184(H), and simultaneously twisting and fibrillating the tape into a twisted strand of fibrillated tape with a coherent network of filaments and fibrils. In the context of the invention the term fibrillation refers to providing the tape with a multitude of confined slits in the machine direction of the tape, with rows of slits displaced laterally with respect to one another. The fibrillation
30 occurs during the twisting of the uniaxially oriented tape and as a consequence of the mechanical treatment of the tape. Fibrillation may partly occur also before the twisting step such as during handling and supply of the uniaxially oriented tape to the twisting equipment as well as after the twisting step during for example transportation, winding and/or compaction. Suitable twisting equipments are the ones commonly used for the
35 processing of continuous filament or staples into yarns and will be well known to the

person skilled in the art.

The process according to the invention may also further comprise a step of post-stretching the twisted strand of fibrillated tape and/or the rope comprising the twisted strand of fibrillated tape. Such a post-stretching step is preferably
5 performed at elevated temperature but below the melting point of the (lowest melting) fibrillated tape in the stands (heat-stretching). For a rope containing fibrillated tape comprising UHMWPE, a preferred temperature lies in the range 100-120°C. Such a heat-stretching step is described in a.o. EP 398843 B1 or US 5901632.

The invention will be described referring to the figures in the
10 drawings.

Figure 1 diagrammatically illustrates a top view of the fibrillated tape upon spreading the twisted fibrillated tape to a flat fibrillated tape. According to the invention the fibrillated tape 10 comprises a multitude of longitudinal slits 20. The slits 20 may be of irregular length and number. The respective distances in the width
15 direction of the tape between adjacent slits may also be of irregular size.

The fibrillated tape upon spreading may show a net-like structure comprising filaments 12 and fibrils 14. The filaments 12 and fibrils 14 may be interconnected without however being continuous. The fibrillated tape may have the appearance of a loosely cohered continuous filament yarn or the appearance of an
20 interconnected web having randomly connected filaments further interconnected with fibrils to form a yarn-like product with a high degree of coherency.

In the context of the invention, the term filament and fibril are both understood to indicate an elongated body being a segment of the tape. Said elongated body (filament or fibril) is delimited in its width direction by either two adjacent slits 22 or
25 by one slit and one edge of the tape 24.

Filaments 12 are such elongated bodies interconnected with the net-like structure of the fibrillated tape by both their two ends 16. Fibrils 14 are such elongated bodies interconnected with the net-like structure by one of their ends 16. Simply, a fibril is a dangling filament.

The dimensions, e.g. width and length, of the filaments and fibrils will be strongly dependant upon the dimensions of the employed tape as well as the fibrillation process. The length of a filament is defined by the distance between two consecutive ends where the filament is interconnected with the net-like structure and may vary broadly in the range from 1 to 1000 mm. Preferably the fibrillation process is
35 adjusted to provide filaments having lengths of from 2 to 500 mm, more preferably from

4 to 200 mm and most preferably from 10 to 100mm. The length of a fibril is defined as the distance between the end where the fibril is interconnected with the net-like structure and the opposite end thereof and may vary broadly in the range from 1 to 1000 mm. Preferably the fibrillation process is adjusted to provide fibrils having a length
5 of from 2 to 500 mm, more preferably from 4 to 200 mm and most preferably from 10 to 100mm.

The thickness of the filaments or the fibrils may be substantially equal to the thickness of the employed tape. The width of a filament or a fibril as being defined by the distance between the 2 adjacent slits forming the filament or fibrils may
10 vary widely, preferably between 20 μm and 20 mm. Preferably the width of a fibril or a filament is from 40 μm to 5 mm, more preferably from 80 μm to 2 mm and most preferably from 100 μm to 1 mm. In a preferred embodiment of the invention, the filaments and fibrils may have a substantially rectangular cross-section.

In a preferred embodiment the process of the present invention
15 provides a twisted strand comprising the fibrillated tape, the strand having a twist level in the range from 1 to 100 turns per meter (tpm). Preferably said twist level is from 2 to 80 tpm, more preferably from 5 to 50 tpm and most preferably from 10 to 35 tpm.

In a yet preferred embodiment, the process of the present invention further comprises the step of braiding, laying, twisting or bundling into a rope at least
20 one of said twisted strands comprising the fibrillated tape.

In an alternative embodiment of the process of the present invention the uniaxially oriented tape is provided from a package. In the context of the invention a package may comprise any adequate form of storage of uniaxially oriented tape such as a bobbin, a roll, a continuous ribbon container or alike. In the instance that the
25 uniaxially oriented tape is provided by unwinding the tape from a package, such unwinding is preferably performed by pulling off the tape over-head from a stationary package. Stationary in the context of the present invention means that the package is not rotating substantially around its winding axis. Optionally the package may move along a predetermined pathway such as typical for braiding equipment.

30 The present invention will now be further elucidated by examples and comparative experiment, without being limited thereto.

Equipment

- A Roblon Tornado 300 (TT83) is used to twist and fibrillate the tape into a strand
- 35 - Roblon Strander RS2-12 - winding unit (TT99) is used to wind the fibrillated tape

onto 12 carriers for a Herzog equipment

- Herzog SE 1/12-266 (TT57) is used for braiding strands comprising the fibrillated tape
 - Zwick 1474 Winding grip / 800 kN horizontal tensile tester Mennens b.v. is used for
- 5 tensile measurement of the braided ropes.

Material

An ultra high molecular weight polyethylene tape was manufactured according to the process described in US 5,091,133. A tape with the following

10 properties was obtained: Linear density of 43300 dtex; Tenacity: 16.5 cN/dtex; Modulus: 1125 cN/dtex; Width: 100 mm; Areal density: 42 g/m²

Production steps

A bobbin of UHMWPE tape was mounted on a regular (un)winding

15 frame (rolling takeoff).

A Roblon Tornado 300 twister was used to twist the tape into strands of fibrillated tape. The twist level was chosen to be 18 tpm. 200 m of fibrillated tape Z-strands and 200 m of fibrillated tape S-strands were produced. Portions of the fibrillated tapes were untwisted for visual inspection. A net-like coherent structure of filaments

20 and fibrils could be observed for both strands of fibrillated tape.

The extent of fibrillation of the tape was determined by cutting from the fibrillated tapes 3 lengths of 5 mm each. The number of individual fragments present in each length was counted. The Z-strand had an average number of 53 fragments and the S-strand had an average number of 51 fragments. The fragments

25 showed random distribution of widths in the range of 0.1 to 5 mm. Such random distribution was considered to be a replication of the widths of the filaments and fibrils of the fibrillated tape.

Bobbins with the Z- and the S-strands of fibrillated tape were mounted on the winding unit of a Roblon Strander RS2-12. With this equipment the

30 strands were wound onto the Herzog carriers. Finally the carriers were mounted onto a Herzog SE 1/12-266 braiding machine and 3 ropes with different braiding periods have been produced.

Rope construction: 12 x 1 x 43300 dtex; Strand twist 18 tpm; Braiding pitch 64 mm, 70 mm and 76 mm. Rope diameter of all 3 ropes was 12 mm.

Test methods as referred to in the present application, are as follows

- Intrinsic Viscosity (IV) is determined according to ASTM-D1 601/2004 or alternatively method PTC-179 (Hercules Inc. Rev. Apr. 29, 1982) at 135°C in decalin, the dissolution time being 16 hours, with DBPC as anti-oxidant in an amount of 2 g/l solution, by extrapolating the viscosity as measured at different concentrations to zero concentration;
- Tensile properties of tapes were measured in accordance with ISO 1184(H). For calculation of the modulus and strength, the tensile forces measured are divided by the linear density of the tape (dtex); the linear density is determined by weighing in mg 10 meters of tape; values in GPa are calculated assuming a density of 0.97 g/cm³.

CLAIMS

1. Process for production of a high tensile strength rope comprising the step of providing an uniaxially oriented tape comprising ultra-high molecular weight polyethylene, the tape having a tensile strength of at least 0.9 GPa as measured in accordance with ISO 1184(H), and simultaneously twisting and fibrillating the tape into a twisted strand of fibrillated tape with a coherent network of filaments and fibrils.
2. The process according to claim 1 characterized in that the twist level of the twisted strand of fibrillated tape is in the range from 1 to 100 turns per meter.
3. The process of claims 1 or 2 characterized in that the linear density of the tape is between 400 and 200,000 dtex.
4. The process of any of the claims 1 to 3 characterized in that the tape has an areal density of between 2 and 200 g/m².
5. The process of any of the claims 1 to 4 characterized in that the tape has a tensile strength of at least 1.2 GPa, preferably 1.5 GPa.
6. The process of any of the claim 1 to 5 further comprising the step of braiding, laying, twisting or bundling into a rope at least one of said twisted strands comprising the fibrillated tape.
7. The process according to any of the claims 1 to 6 further characterized in that the uniaxially oriented tape is provided from a package.
8. The process according to claim 7 characterized in that the unwinding is performed by pulling off the tape over-head from a stationary package.
9. A rope obtainable by a process according to any of the claims 1 to 8.
10. The rope of claim 9 comprising at least one strand wherein said strand comprises a fibrillated tape having a tensile strength before fibrillation of at least 0.9 GPa as measured in accordance with ISO 1184(H) wherein the fibrillated tape comprises a coherent network of filaments and fibrils.
11. The rope of claim 9 or 10 characterized in that it comprises more than one strand comprising a fibrillated tape.
12. The rope according to any of the claims 9 to 11 characterized in that the rope is of a braided construction.
13. The rope according to any of the claims 9 to 12 characterized in that at least one strand is a braided rope.
14. A product comprising any one of the ropes according to claims 9 to 13.

15. The product of claim 14, wherein the product is chosen from the group consisting of mooring lines, towing lines, lifting ropes, off-shore ropes, fishing lines, fishing nets, cargo nets, cargo curtains, belts, woven fabrics, raschels and slings.

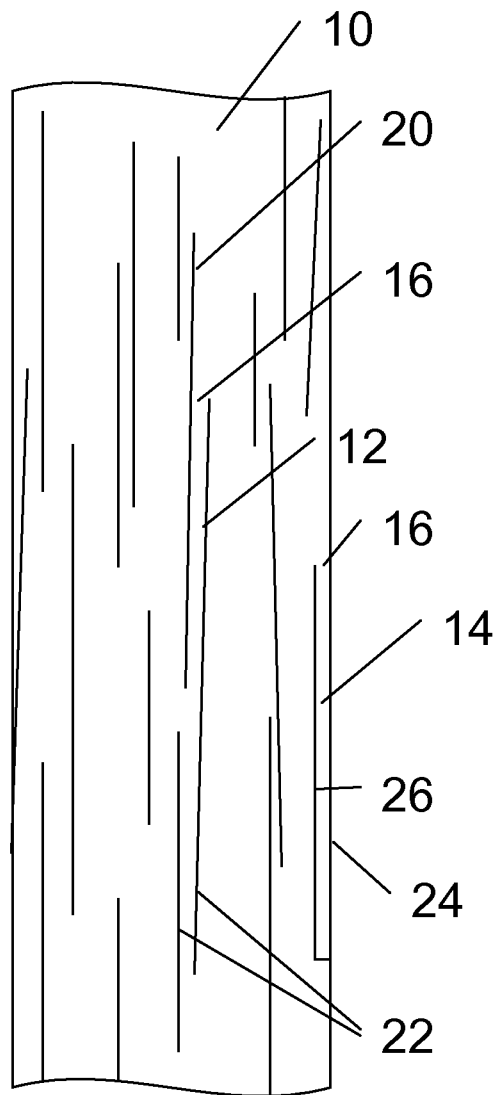

Figure 1

INTERNATIONAL SEARCH REPORT

International application No PCT/EP2012/076005
--

A. CLASSIFICATION OF SUBJECT MATTER
INV. D07B5/00 D07B1/02
 ADD.

According to International Patent Classification (IPC) or to both national classification and IPC

B. FIELDS SEARCHED

Minimum documentation searched (classification system followed by classification symbols)
D07B D04C

Documentation searched other than minimum documentation to the extent that such documents are included in the fields searched

Electronic data base consulted during the international search (name of data base and, where practicable, search terms used)
EPO-Internal , WPI Data

C. DOCUMENTS CONSIDERED TO BE RELEVANT

Category*	Citation of document, with indication, where appropriate, of the relevant passages	Relevant to claim No.
Y	US 3 500 626 A (SANDI FORD DENIS JAMES HENRY) 17 March 1970 (1970-03-17) the whole document -----	1-15
Y	GB 1 040 663 A (PLASTICISERS LTD) 1 September 1966 (1966-09-01) the whole document -----	11
A		1,9
Y	US 3 380 243 A (STANTON ROBERT L) 30 April 1968 (1968-04-30) the whole document -----	6, 12, 15
	-/- .	

Further documents are listed in the continuation of Box C. See patent family annex.

* Special categories of cited documents :

<p>"A" document defining the general state of the art which is not considered to be of particular relevance</p> <p>"E" earlier application or patent but published on or after the international filing date</p> <p>"L" document which may throw doubts on priority claim(s) or which is cited to establish the publication date of another citation or other special reason (as specified)</p> <p>"O" document referring to an oral disclosure, use, exhibition or other means</p> <p>"P" document published prior to the international filing date but later than the priority date claimed</p>	<p>"T" later document published after the international filing date or priority date and not in conflict with the application but cited to understand the principle or theory underlying the invention</p> <p>"X" document of particular relevance; the claimed invention cannot be considered novel or cannot be considered to involve an inventive step when the document is taken alone</p> <p>"Y" document of particular relevance; the claimed invention cannot be considered to involve an inventive step when the document is combined with one or more other such documents, such combination being obvious to a person skilled in the art</p> <p>"&" document member of the same patent family</p>
---	---

Date of the actual completion of the international search 4 April 2013	Date of mailing of the international search report 18/04/2013
--	---

Name and mailing address of the ISA/ European Patent Office, P.B. 5818 Patentlaan 2 NL - 2280 HV Rijswijk Tel. (+31-70) 340-2040, Fax: (+31-70) 340-3016	Authorized officer Uhl i g, Robert
--	--

INTERNATIONAL SEARCH REPORT

International application No

PCT/EP2012/076005

C(Continuation). DOCUMENTS CONSIDERED TO BE RELEVANT		
Category*	Citation of document, with indication, where appropriate, of the relevant passages	Relevant to claim No.
Y	MCKENNA H A ET AL: "Handbook of fibre rope technology, passages" , 1 January 2004 (2004-01-01) , HANDBOOK OF FIBRE ROPE TECHNOLOGY; [WOODHEAD PUBLISHING IN TEXTILES] , WOODHEAD PUBLISHING LTD, ENGLAND, PAGE(S) 47 - 59, 186, XP002584385 , ISBN: 978-1-85573-606-1 cited in the application on pages 51,53	1-15
A	----- US 3 791 129 A (SHUFORD A) 12 February 1974 (1974-02-12) column 4, line 27 - column 5, line 2 column 6, line 21 - line 25 column 6, line 49 - line 50	1,9-12 , 14
A	----- GB 1 232 450 A (DUNLOP) 19 May 1971 (1971-05-19) the whole document	1,9-12 , 14
A	----- FR 1 428 438 A (PLASTICISERS LTD) 11 February 1966 (1966-02-11) the whole document	1,9-12 , 14
A	----- US 3 371 477 A (PIERRE FELIX) 5 March 1968 (1968-03-05) the whole document	1,9-12 , 14
A	----- US 3 199 284 A (FREDERICK SERAGG) 10 August 1965 (1965-08-10) the whole document	1

INTERNATIONAL SEARCH REPORT

Information on patent family members

International application No PCT/EP2012/076005

Patent document cited in search report	Publication date	Patent family member(s)	Publication date
US 3500626	A	17-03-1970	BE 666243 A 04-04-2013 DE 1660364 AI 06-04-1972 GB 1104758 A 28-02-1968 LU 48961 A 01-09-1965 NL 6508429 A 03-01-1966 US 3500626 A 17-03-1970
GB 1040663	A	01-09-1966	BE 661133 A 15-09-1965 CH 494836 A 15-08-1970 DE 1660552 AI 06-04-1972 FI 45669 B 02-05-1972 GB 1040663 A 01-09-1966 JP S5112744 BI 22-04-1976 LU 48201 A 17-05-1965 NL 6503343 A 17-09-1965 SE 332870 B 22-02-1971
US 3380243	A	30-04-1968	GB 1156975 A 02-07-1969 US 3380243 A 30-04-1968
US 3791129	A	12-02-1974	NONE
GB 1232450	A	19-05-1971	NONE
FR 1428438	A	11-02-1966	NONE
US 3371477	A	05-03-1968	BE 676385 A 11-08-1966 CH 441609 A 15-08-1967 FR 1432800 A 25-03-1966 GB 1067704 A 03-05-1967 NL 6601471 A 15-08-1966 US 3371477 A 05-03-1968
US 3199284	A	10-08-1965	DE 1435668 AI 20-02-1969 GB 1058182 A 08-02-1967 US 3199284 A 10-08-1965