

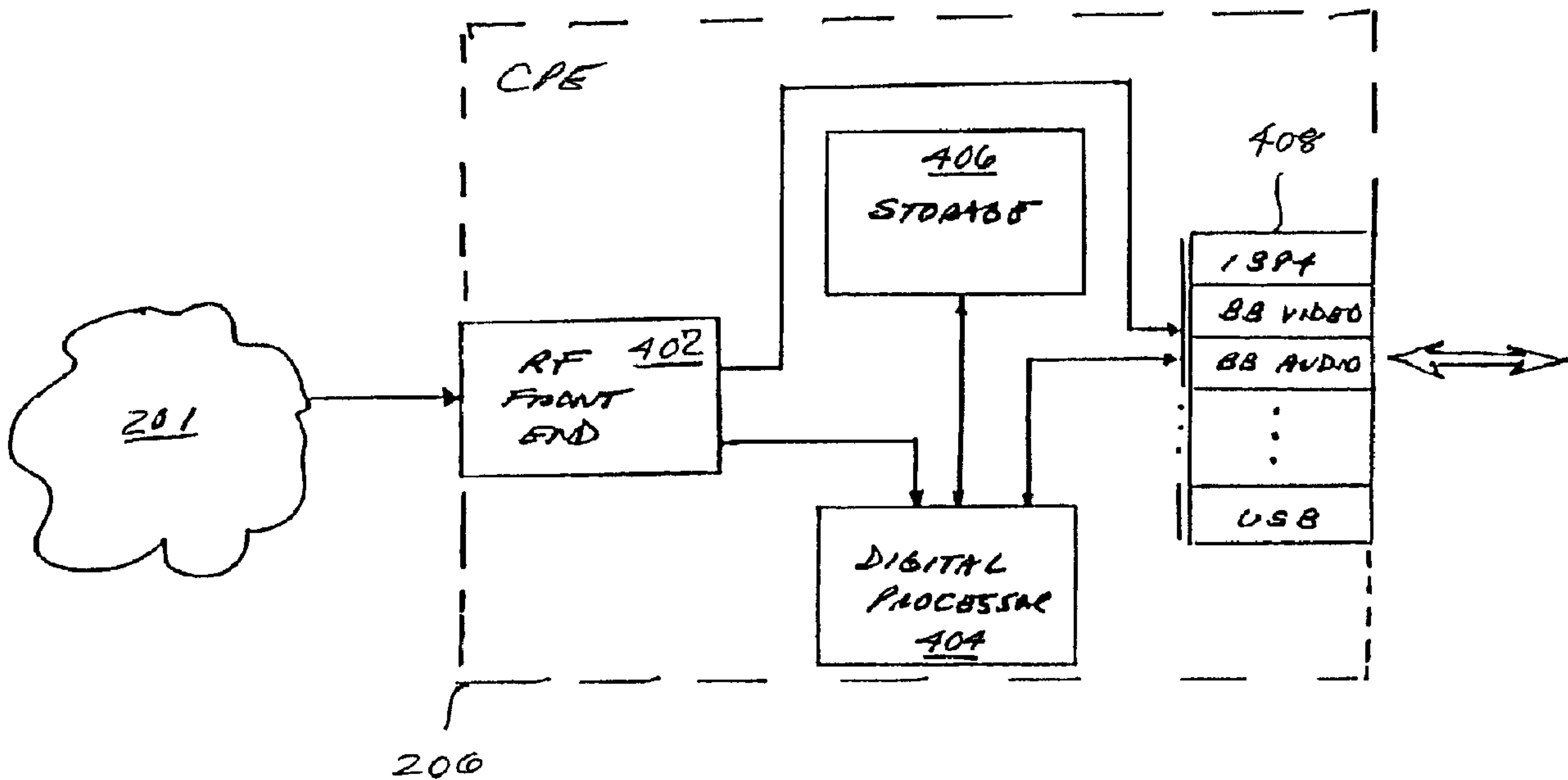

(22) **Date de dépôt/Filing Date:** 2005/12/14  
 (41) **Mise à la disp. pub./Open to Public Insp.:** 2006/06/22  
 (45) **Date de délivrance/Issue Date:** 2017/11/21  
 (62) **Demande originale/Original Application:** 2 590 138  
 (30) **Priorité/Priority:** 2004/12/15 (US11/013,671)

(51) **Cl.Int./Int.Cl.** *H04N 21/2365* (2011.01),  
*H04L 12/70* (2013.01), *H04N 7/015* (2006.01)  
 (72) **Inventeurs/Inventors:**  
CARLUCCI, JOHN B, US;  
HELMS, WILLIAM, US;  
WILLIAMSON, LOUIS D., US  
 (73) **Propriétaire/Owner:**  
TIME WARNER CABLE ENTERPRISES LLC, US  
 (74) **Agent:** GOWLING WLG (CANADA) LLP

(54) **Titre :** PROCÉDE ET APPAREIL DE DIFFUSION A LARGE BANDE DE CONTENUS  
 (54) **Title:** METHOD AND APPARATUS FOR WIDEBAND DISTRIBUTION OF CONTENT



(57) **Abrégé/Abstract:**

A method and apparatus to create and transmit transport multiplexes comprising one or more levels of service over a network. In one embodiment, the level of service comprises high definition (HD) content or programs, and the transmitted multiplexes are distributed over a plurality of downstream RF carriers in a cable network simultaneously. A head-end architecture for performing the multiplexing and distribution of multiple HD programs over the multiple carriers (i.e., in a "wideband" configuration) is disclosed. CPE having one or more wideband tuners is also disclosed, the CPE being adapted to receive the multiplexed HD content from the various RF carriers, and demultiplex it in order to permit decoding and subsequent viewing by the user. The use of multiple HD source programs with the multiplex advantageously provides for enhanced statistical multiplexing by providing a larger "pool" of constituent inputs and available carriers.

**ABSTRACT**

A method and apparatus to create and transmit transport multiplexes comprising one or more levels of service over a network. In one embodiment, the level of service comprises high definition (HD) content or programs, and the transmitted multiplexes are distributed over a plurality of downstream RF carriers in a cable network simultaneously. A head-end architecture for performing the multiplexing and distribution of multiple HD programs over the multiple carriers (i.e., in a "wideband" configuration) is disclosed. CPE having one or more wideband tuners is also disclosed, the CPE being adapted to receive the multiplexed HD content from the various RF carriers, and demultiplex it in order to permit decoding and subsequent viewing by the user. The use of multiple HD source programs with the multiplex advantageously provides for enhanced statistical multiplexing by providing a larger "pool" of constituent inputs and available carriers.

## METHOD AND APPARATUS FOR WIDEBAND DISTRIBUTION OF CONTENT

5

### Priority

This application claims priority to U.S. Patent Application Publication No. 2006/0130113 filed December 15, 2004 and entitled "Method and Apparatus for Wideband Distribution of Content".

10

### Background of the Invention

#### 1. **Field of the Invention**

The invention relates generally to the field of digital content distribution. In one exemplary aspect, the invention relates to methods and apparatus to create, transmit, receive and decode wideband transport streams comprising one or more service levels, such as standard definition (SD) and high definition (HD) television programs.

#### 2. **Description of Related Technology**

In conventional cable television networks, the available spectrum for transmission to customer premises ("downstream spectrum") is divided into RF channels that have a given frequency bandwidth (e.g., 6 MHz in the United States) and occupy spectral slots between a higher and lower bound, such as 54 MHz and 860 MHz. A 6 MHz wide channel is used to carry, for example, a single channel analog television program or a multi-program digital television stream (broadcast or on-demand) or a DOCSIS downstream transport stream to the customer premises.

Since cable signals are transmitted using a Quadrature Amplitude Modulation (QAM) scheme, available payload bitrate for typical modulation rates (QAM-256, QAM-64) used on HFC systems is roughly, e.g., 38 Mbps (for QAM-256). For conventional cable networks that use MPEG-2 audio/video compression technology, the available bandwidth (38 Mbps) on one 6-MHz channel can accommodate a group of approximately 10-12 standard definition television programs. This group of television programs is typically created at a cable headend by using a program multiplexer. Fig. 1 shows functional block diagram of such a multiplexing stage typically used at a headend.

In this architecture, a pre-determined number of programs in MPEG-2 format comprise a series of inputs 100 to a quantization stage 102. The quantization stage is so called because it has the ability to alter the bitrate of each stream in real time. These rate-altered programs are multiplexed together in a multiplexing stage 104 that produces an output transport stream 106 with the target rate suitable for modulation over a single channel carrier. The multiplexing stage also provides substantially real time feedback to the quantization stage via feedback loop 108.

### *High Definition Services*

In recent times, High Definition television (HDTV) has become an increasingly popular format for transmission and viewing television programming. More and more households and other premises are beginning to purchase High Definition (HD) televisions (HDTV). To keep up with this trend, cable operators have begun offering HD television programs to cable customers, and have recently also started deploying HD “on-demand” (OD) services.

Transmission of an entertainment-quality HD program requires about 4-to-6 times as much bandwidth as an SD program. For example, terrestrial HDTV signals are broadcast using 19.2 Mbps bitrate for video, which is substantially more than the typical 3-4 Mbps rate used for transmission of entertainment-quality SD program over cable networks. In spite of the use of latest video compression techniques, cable operators still require upwards of 12-15 Mbps bitrates for transmission of MPEG-2 Main Profile – High Level (MP@HL) HD programs.

Since transmission of HD programs results in a significantly higher usage of network bandwidth, network operators are looking for improved methods to reduce this burden by creating bitrate-efficient multiplexes of HD programs.

### *Statistical Multiplexing of HD Signals*

Statistical multiplexing is a technique used to efficiently pack multiple programs within a transport stream. This technique relies on the principle that instantaneous bandwidth required to transmit a program fluctuates over time, typically based on the ease of compression of the video content. This makes bandwidth-efficient transmission of multiple programs possible as a multiplex by staggering peak bandwidth requirements of the programs. Conventional approaches to statistical multiplexing have recognized that the greater the number of programs in a multiplex (i.e., “pool size”), the better the chances of using bandwidth efficiently.

However, in the context of transmission of HD programs over cable networks using conventional techniques, the applicability of statistical multiplexing is limited. The main reason for this is that due to the relatively high bitrates of HD programs, a typical transport stream corresponding to a 6 MHz cable channel can only carry 2 to 3 HD programs. This limits the effectiveness of statistically multiplexing HD programs in a multiplex with other HD or SD programs.

Accordingly, a technique that allows for the creation and transmission of transport multiplexes that comprise a larger number of HD programs, thereby improving the opportunity to efficiently group the programs for transmission over networks, will be useful to address the bandwidth burden problem. Such a transport multiplex will typically have a bitrate higher than what can be sent on one RF channel; hence the term "wideband multiplex" can be used to refer to such a multiplex.

United States Patent No. 5,708,664 to Budge, et al. issued January 13, 1998 entitled "Statistical multiplexing" discloses a transmitter for transmitting a plurality of digital signals through a plurality of channels, the channels having a predetermined total allocated bitrate. The transmitter includes a plurality of encoders each associated with one channel, a multiplexer for receiving the encoded digital signals and for transmitting the encoded signals as a stream of data, and operable for adjusting the distribution of the bitrate allocation between and among the encoded signals, and a processing device for providing an indication of a target quality and an actual quality for each channel and for causing the multiplexer to repeatedly adjust the distribution of the bitrate allocation in response to differences between the indicated actual quality and the indicated target quality for each channel so as to equalize differences between the actual and target quality across at least some of the channels. By grouping encoders together in "statistical multiplex groups", and making real time decisions about the bitrate requirements for those encoders, bitrate can be allocated to maximize picture quality for the group. For a variety of different picture sources in a statistical multiplex group, to achieve a target picture quality the bitrate requirements of each will vary with coding difficulty. Thus, a channel within the statistical multiplex group that is experiencing little difficulty in encoding its picture can free bits to channels that are having greater difficulty. The effect is to smooth the picture quality and subjectively improve it.

United States Patent No. 6,219,358 to Pinder, et al. issued April 17, 2001 entitled "Adaptive rate control for insertion of data into arbitrary bit rate data streams" discloses apparatus wherein the rate of insertion of data, such as MPEG table packets, into an

outgoing bit stream is varied by a packet handler. The packet handler, which is located in a modulator in a cable television system headend, comprises control logic and a packet router. The actual insertion rate of the outgoing data is based on the bit stream's available capacity for insertion of data and the desired insertion rate of the data. When the available capacity for insertion equals or exceeds the desired insertion rate, the actual insertion rate equals the desired insertion rate. When the available capacity for insertion is less than the desired insertion rate, the actual insertion rate is reduced from the desired insertion rate. The invention dynamically determines the available capacity for insertion and adjusts the actual insertion rate.

10 United States Patent Publication 20010055336 to Krause, et al. published December 27, 2001 and entitled "Compressed-Video Reencoder System For Modifying The Compression Ratio Of Digitally Encoded Video Programs" discloses a compressed video decoder/encoder (reencoder) system for varying the compression ratio of a compressed video program. The composite reencoder system implements tightly coupled  
15 elements for decoding and encoding compressed video data implementing techniques of header forwarding and utilizing an architecture in which a shared motion compensator supports both decoding and encoding operations simultaneously. The reencoder system may be introduced in a statistical multiplexer for generating a compressed video data stream multiplex suitable for use in cable distribution and other video distribution  
20 systems.

United States Patent Publication No. 20020085584 to Itawaki, et al. published July 4, 2002 entitled "Statistical multiplex system, statistical multiplex controller and method of statistical multiplex" discloses a statistical multiplex system, a statistical multiplex controller and a method of statistical multiplex, which can assign bit rates to  
25 program data and auxiliary data, ostensibly to improve image quality. A statistical multiplex system is provided with: a plurality of image encoders for encoding a plurality of program data; an information encoder for encoding the auxiliary data; a multiplexing apparatus for multiplexing output thereof, and a statistical multiplex controller for controlling each of the image encoders and the information encoder. The statistical  
30 multiplex controller is made to set the bit rate to be assigned to the information encoder first, and to assign the remaining bit rates to each of the image encoders.

United States Patent Publication No. 20030083054 to Francesca, et al. published May 1, 2003 and entitled "Multi-channel broadband content distribution system" discloses a system for managing bandwidth in a content distribution system. The system

can be incorporated into the content head end of the content distribution system. The system includes a program multiplexer, a multi-channel modulating module, a channel multiplexer, a digital-to-analog converter and a frequency block-up converter, all arranged in a sequential configuration. Packets representing respective content programs are fed to the program multiplexer. The program multiplexer multiplexes the packets into an output queue. How the packets are multiplexed by the program multiplexer into the output queue depends on the specific design and/or application. Packets from the output queue are then fed to the multi-channel modulating module. The multi-channel modulating module receives the packets and routes them to various modulators representing corresponding RF channels. The various modulators then modulate the respective packets to generate corresponding RF signals. These RF signals are then multiplexed by the channel multiplexer into a multi-channel RF signal. The multi-channel RF signal is then forwarded to the digital-to-analog converter for conversion into an analog, multi-channel RF signal. The frequency block-up converter then takes the analog multi-channel RF signal and shifts its to a higher frequency band for transmission. The shifted analog multi-channel RF signal is then transmitted over a medium to one or more customer premises equipment. Notwithstanding the foregoing, this solution fails to provide mechanisms for performing the important steps of encryption at a headend, and corresponding decryption at the customer premises equipment (CPE). Also, a corresponding CPE configuration that can receive wideband signals (essential to the operation of such a system) is not provided.

Based on the foregoing, it is evident that while the prior art has in general recognized the utility of wideband content transmission, it lacks apparatus and methods to adequately implement this approach. Specifically, prior art does not teach how to create transport multiplexes of the type needed to efficiently and effectively transport such wideband signals by enforcing various multiplexing rules across multiple carriers, nor does it address backwards compatibility with legacy devices.

What is needed are improved apparatus and methods to create, transmit and receive wideband multiplexes that allow flexible encryption and multiplexing of programs and program information tables, and which provide backwards compatibility with legacy customer premises equipment. Such improved apparatus and methods would also, *inter alia*, allow for a larger statistical multiplex pool size, thereby increasing the leverage in efficiency provided by the statistical multiplexing approach in an HD environment.

Summary of the Invention

The present invention addresses the foregoing needs by providing, in various embodiments, methods and apparatus for wideband transmission of content.

In a first aspect of the invention, a content distribution system adapted for efficient transmission of High Definition (HD) programs is disclosed. In one embodiment, the system comprises: first apparatus adapted to receive a plurality of HD programs; server apparatus operatively coupled to the first apparatus and configured to process the plurality of HD programs based on a plurality of operator-controlled rules; and transmission apparatus configured to transmit the processed programs across a plurality of RF channels, at least a portion of the channels being non-contiguous. Portions of each of the programs are transmitted using the plurality of RF channels. The processing of the programs further comprises the insertion of non-content data (such as PID or SI data) into the programs, the data being useful for receiving the programs at a receiver.

In a second aspect of the invention, improved customer premises equipment (CPE) for use in a content-based network is disclosed. In one embodiment, the CPE is adapted to receive transmitted content substantially simultaneously from a plurality of information carriers present on a plurality of RF channels, and comprises: a tuner stage capable of receiving first signals simultaneously from the plurality of carriers; a demodulator stage adapted to demodulate a plurality of the first signals; a decryption stage adapted to decrypt at least a portion of the demodulated signals; and content reassembly apparatus operatively coupled to the decryption stage, the reassembly apparatus adapted to reassemble the decrypted and demodulated signals into the transmitted content.

In a third aspect of the invention, a method of operating a cable network having a plurality of legacy-capable CPE and a plurality of "wideband" CPE operatively coupled thereto is disclosed. In one embodiment, the method comprises: distributing a first program comprising a plurality of content elements, the act of distributing comprising sending the content elements over multiple carriers of the network; and providing program information data as part of the distributing such that the wideband CPE can receive and decode the first program, the program information being structured so as to preclude the legacy-capable CPE from decoding the first program.

In a fourth aspect of the invention, improved statistical multiplex apparatus useful in a cable network is disclosed. In one embodiment, the apparatus comprises: a first process adapted to selectively extract content data packets associated with a plurality of

different programs from a plurality of N input queues; and a second process adapted to selectively allocate the extracted content data packets to a plurality of M RF channels; wherein the packets associated with at least one of the plurality of different programs are distributed across multiple ones of the M RF channels. In one variant, the first and  
5 second processes are controlled according to "round-robin" algorithms. In a second variant, the first process comprises a round-robin algorithm, while the second comprises a "most-loaded" or "least-loaded" algorithm.

In a fifth aspect of the invention, an improved content distribution system is disclosed, comprising: first apparatus adapted to receive a plurality of content; content  
10 server apparatus operatively coupled to the first apparatus and configured to process the plurality of content based on a plurality of operator-controlled rules; and transmission apparatus configured to transmit the processed content across a plurality of RF channels, at least a portion of the channels being non-contiguous; wherein at least portions of a program contained within the content are respectively transmitted using multiple ones of  
15 the RF channels.

In a sixth aspect of the invention, a method of improving the bandwidth utilization of an associated cable system for delivery of high definition (HD) video is disclosed. In one embodiment, the cable system comprises a content distribution system having apparatus adapted to receive a plurality of content, content server apparatus  
20 configured to process the plurality of content based on a plurality of operator-controlled rules, and transmission apparatus configured to transmit the processed content across a plurality of at least partly contiguous RF channels, and the method comprises: providing a plurality of HD programs and a plurality of SD programs as part of the content; providing a plurality of other data programs as part of the content; and multiplexing the  
25 HD, SD, and other data programs onto the plurality of RF channels.

In a seventh aspect of the invention, a head-end content distribution system for use in a cable network is disclosed. In one embodiment, the system comprises: at least one interface adapted to receive a plurality of input content streams; a multiplexer that processes the plurality of input content streams to produce a plurality of output streams  
30 in multiplexed form; an encrypter stage that encrypts the plurality of output streams; a modulation stage that modulates the encrypted output streams onto a plurality of carriers; and a frequency upconversion stage that translates the modulated signals into RF channels for delivery over multiple carriers within the network.

In an eighth aspect of the invention, a method of operating CPE within a cable network is disclosed. In one embodiment, the network comprises a plurality of legacy-capable CPE and a plurality of wideband CPE operatively coupled thereto, and the method comprises: receiving at least one first program comprising a plurality of content elements, the act of receiving comprising receiving the content elements over multiple carriers of the network; and extracting program information data as part of the act of receiving such that the wideband CPE can decode the at least one first program, the program information being structured so as to preclude the legacy-capable CPE from decoding the at least one first program.

10 In a ninth aspect of the invention, a method of providing cable network services to a service area is disclosed. In one embodiment, the service area has a plurality of first CPE installed therein, the first CPE being adapted to receive at least one program over a first number of channels of the cable network. The method comprises: providing second CPE to a first portion of the service area (such as via a planned, program, or incidental  
15 CPE upgrade), the second CPE being adapted to receive at least one program simultaneously over a second number of RF channels of the cable network; transmitting at least one program over the first number of channels to the service area for a first period of time; providing second CPE to a second portion of the service area; and transmitting at least one program over the second number of channels to the service area  
20 thereafter. The operation of the newer (upgraded) wideband CPE using a number of channels less than its capacity for a period of time allows for migration of older CPE to the newer capability over time without leaving the older CPE users "stranded" of forcibly requiring them to upgrade or lose service.

#### 25 Brief Description of the Drawings

The above and other features and advantages of the present invention are hereinafter described in the following detailed description of illustrative embodiments to be read in conjunction with the accompanying drawings and figures, wherein like reference numerals are used to identify the same or similar system parts and/or method  
30 steps, and in which:

Fig. 1 is a functional block diagram illustrating an exemplary prior art multiple-input, single-output multiplexer with a quantization step, and configured to perform rate shaping.

Fig. 2 is a functional block diagram illustrating one exemplary embodiment of an

HFC cable network architecture useful with the present invention.

Fig. 2a is a functional block diagram illustrating one exemplary embodiment of the multiplexer, modulator and encryption module (MEM) of the network of Fig. 2, in which a plurality (e.g., 12) HD programs are multiplexed and modulated on multiple QAM carriers.

5 Fig. 2b is a functional block diagram illustrating a second exemplary embodiment of the multiplexer, modulator and encryption module (MEM) of the network of Fig. 2, wherein separate modulators and encryptors are utilized.

Fig. 2c is a functional block diagram illustrating a third exemplary embodiment of the multiplexer, modulator and encryption module (MEM) of the network of Fig. 2,  
10 wherein separate upconverters are used.

Fig. 3 is a functional block diagram illustrating one exemplary embodiment of the wideband multiplexer according to the present invention, showing quantization, multiplexing and encryption functions.

Fig. 4 is a block diagram illustrating one exemplary embodiment of the CPE of the  
15 present invention showing various components thereof.

Fig. 4a is a functional block diagram of the CPE of Fig. 4 showing the receipt of a wideband signal, processing of the signal, and transfer to an HD decoder.

Fig. 5 is a logical flow diagram of an exemplary computer-implemented process used to perform content downloads in accordance with one embodiment of the present  
20 invention.

Fig. 6 is a functional block diagram of another exemplary network architecture according to the invention, wherein an optical network and Edge QAM are utilized.

Fig. 6a is a functional block diagram of yet another exemplary network architecture according to the invention, wherein both a wideband head-end MEM and a  
25 separate optical network and Edge QAM are utilized.

#### Detailed Description of the Invention

Reference is now made to the drawings wherein like numerals refer to like parts throughout.

30 As used herein, the term "on-demand" or "OD" is meant to include any service that enables real time, quasi-real time (e.g. "trick" mode delivery) or even non-real time delivery of content such as audio and/or video programs at any resolution, or data, based on some action of a user, customer, or its proxy. Such content may be, for example, stored or temporarily cached on a server or other device, or streamed directly from a source.

As used herein, the terms “multi-systems operator” and “MSO” refer to a cable, satellite, or terrestrial network provider having infrastructure required to deliver services including programming and data over those mediums.

As used herein, the terms “network” and “bearer network” refer generally to any  
 5 type of telecommunications or data network including, without limitation, hybrid fiber coax (HFC) networks, satellite networks, telco networks, and data networks (including  
 MANs, WANs, LANs, WLANs, PANs, internets, and intranets). Such networks or  
 portions thereof may utilize any one or more different topologies (e.g., ring, bus, star,  
 loop, etc.), transmission media (e.g., wired/RF cable, RF wireless, millimeter wave,  
 10 optical, etc.) and/or communications or networking protocols (e.g., SONET, DOCSIS,  
 IEEE Std. 802.3, 802.11, 802.15, 802.16 (WiMAX), ATM, X.25, Frame Relay, 3GPP,  
 3GPP2, WAP, SIP, UDP, FTP, RTP/RTCP, H.323, etc.).

As used herein, the term “QAM” refers generally to modulation schemes used for  
 sending signals over coaxial cable or other networks. Such modulation scheme might use  
 15 any constellation level (e.g. QAM-16, QAM-64, QAM-256 etc.) depending on the details of  
 a particular cable or other (e.g., satellite) network. A QAM may also refer to a physical  
 channel modulated according to said schemes.

As used herein, the term "head-end" refers generally to a networked system  
 controlled by an operator (e.g., an MSO or multimedia specific operator) that distributes  
 20 programming to MSO clientele using client devices. Such programming may include  
 literally any information source/receiver including, *inter alia*, free-to-air TV channels, pay  
 TV channels, interactive TV, and the Internet. DSTBs may literally take on any  
 configuration, and can be retail devices meaning that customers may or may not obtain their  
 DSTBs from the MSO exclusively. Accordingly, it is anticipated that MSO networks may  
 25 have client devices from multiple vendors, and these client devices will have widely  
 varying hardware capabilities. Multiple regional head-ends may be in the same or different  
 cities.

As used herein, the term “content” refers to audio, video, graphics files (in  
 uncompressed or compressed format), icons, software, text files and scripts, data, binary  
 30 files and other computer-usable data used to operate a client device and produce desired  
 audio-visual effects on a client device for the viewer.

As used herein, the terms “client device” and “end user device” include, but are  
 not limited to, personal computers (PCs) and minicomputers, whether desktop, laptop, or  
 otherwise, set-top boxes such as the Motorola DCT2XXX/5XXX and Scientific Atlanta

Explorer 2XXX/3XXX/4XXX/8XXX series digital devices, personal digital assistants (PDAs) such as the Apple Newton®, “Palm®” family of devices, handheld computers, personal communicators such as the Motorola Accompli devices, J2ME equipped devices, cellular telephones (including “smart phones”), wireless nodes, or literally any  
 5 other device capable of interchanging data with a network.

Similarly, the terms “Customer Premises Equipment (CPE)” and “host device” refer to any type of electronic equipment located within a customer or user premises and connected to a network. The term “host device” refers generally to a terminal device that has access to digital television content via a satellite, cable, or terrestrial network. The  
 10 host device functionality may be integrated into a digital television (DTV) set. The term “customer premises equipment” (CPE) includes electronic equipment such as set-top boxes, televisions, Digital Video Recorders (DVR), gateway storage devices (Furnace), and ITV Personal Computers.

As used herein, the term “application” refers generally to a unit of executable  
 15 software that implements a certain functionality or theme. The themes of applications vary broadly across any number of disciplines and functions (such as on-demand content management, e-commerce transactions, brokerage transactions, home entertainment, calculator etc.), and one application may have more than one theme. The unit of executable software generally runs in a predetermined environment; for example, the unit  
 20 could comprise a downloadable Java Xlet™ that runs within the JavaTV™ environment.

As used herein, the term “computer program” is meant to include any sequence or human or machine cognizable steps which perform a function. Such program may be rendered in virtually any programming language or environment including, for example, C/C++, Fortran, COBOL, PASCAL, assembly language, markup languages (e.g.,  
 25 HTML, SGML, XML, VoXML), and the like, as well as object-oriented environments such as the Common Object Request Broker Architecture (CORBA), Java™ (including J2ME, Java Beans, etc.) and the like.

The term “component” in the context of software refers generally to a unit or portion of executable software that is based on a related set of functionalities. For  
 30 example, a component could be a single class in Java™ or C++. Similarly, the term “module” refers generally to a loosely coupled yet functionally related set of components.

As used herein, the term “server” refers to any computerized component, system or entity regardless of form, which is adapted to provide data, files, applications, content, or other services to one or more other devices or entities on a computer network.

As used herein, the term “legacy” refers to any component, system, process, or method which is prior to the most current generation, revision, or modification of such component, system, process, or method.

### *Overview*

The present invention discloses apparatus and methods to create, transmit and receive wideband multiplexes that allow for efficient and flexible multiplexing of programs and program information tables. These apparatus and methods also advantageously provide backwards compatibility with legacy customer premises equipment (CPE), such that legacy CPE can receive and decode “legacy” content, while the wideband CPE of the present invention within the same network can receive and decode both the legacy content and the content (e.g., HD programs) distributed over the wideband carrier pool.

In one exemplary embodiment of the invention (adapted for HFC cable networks), elements in both the head-end and CPE are specially adapted to utilize existing transmission infrastructure to transmit and receive both the multiplexed wideband and legacy content.

At the head-end, transport stream processing comprises statistical multiplexing of content obtained via a plurality of input streams into one or more common “multiplexes” (Multi-program transport streams, or MPTS). These multiplexes are then split or divided across multiple different physical carriers for transmission across the network (including modulation, encryption, and RF upconversion). System information (SI) tables are also created at the head-end for inclusion within the transmitted signals. Any packet ID (PID) re-mapping performed by the modulators is optionally made consistent across the entire statistical multiplex pool.

The receiving CPE contains multiple tuners (or a single wide-band tuner) that allow the CPE to receive the signals from all of the relevant physical carriers simultaneously. The carriers are demodulated, and channel-based decryption and basic demultiplexing (recombination) is performed. The streams are then delivered to a transport demultiplexor which demultiplexes all of the streams resident within the statistical multiplex.

Advantageously, the present invention may be implemented using existing head-end infrastructure; i.e., via software modifications to existing rate shaper and multiplexer devices. Similarly, only minimal modifications to the CPE (including the addition of one or more wideband tuners and software modifications) are required to implement the invention.

One salient benefit obtained by implementing the invention relates to the increase or enhancement in the size of the “pool” available to the HD statistical multiplex processes of the head-end. Specifically, an increased number of variable rate content streams can be included in a multiplex, and the multiplex can be distributed over multiple different carriers,  
5 which collectively makes the statistical multiplexing process more effective.

#### *Description of Exemplary Embodiments*

Exemplary embodiments of the apparatus and methods of the present invention are now described in detail. While these exemplary embodiments are described in the  
10 context of the aforementioned hybrid fiber coax (HFC) cable architecture having an multi-system operator (MSO), digital networking capability, and plurality of client devices/CPE, the general principles and advantages of the invention may be extended to other types of networks and architectures where the efficient allocation of larger-bandwidth programs or content is desired. Hence, the following description is merely  
15 exemplary in nature.

It will also be appreciated that while described generally in the context of a network providing service to a customer (i.e., home) end user domain, the present invention may be readily adapted to other types of environments including, e.g., commercial/enterprise, and government/military applications . Myriad other applications  
20 are possible.

It is also noted that while the following discussion is cast primarily in terms of two service levels (i.e., SD and HD), the methods and apparatus disclosed herein can be extended to other numbers and types of service levels. For example, it is foreseeable that yet even higher levels of definition may be employed in the future (e.g., “ultra-high  
25 definition” or UHD), thereby allowing intelligent bandwidth allocation between three service levels (SD, HD, and UHD). As another option, multiple levels or rates may be present with one of the aforementioned service levels, such as where the SD level includes levels SD1, SD2, ...SDn, and the HD level similarly includes HD1, HD2,...HDn, with each of these sub-levels having different data rates and/or other  
30 characteristics. Relevant portions of the methods and apparatus described in co-pending and co-owned U.S. Patent Application Serial No. 10/881,979 filed June 29, 2004 and entitled “Method And Apparatus For Network Bandwidth Allocation”

may also be used consistent with the invention described herein.

It is further noted that while described primarily in the context of 6 MHz RF channels, the present invention is applicable to literally any frequency/bandwidth, such as for example 8 MHz channels. Furthermore, as referenced above, the invention is in no way limited to traditional cable system frequencies (i.e., below 1 GHz), and in fact  
5 may be used with systems that operate above 1 GHz band in center frequency or bandwidth, to include without limitation so-called ultra-wideband systems.

Also, any references to "RF carriers" herein are in no way limited to coaxial cable systems; the various approaches of the present invention may also readily be applied to wireless environments such as, e.g., satellite systems.

10 Although the methods and apparatus of the present invention have been described with reference to Internet Protocol (IP) based networks, it will be appreciated that the teachings presented herein are equally applicable to networks that use other transport protocols.

Lastly, while described primarily in the context of a downstream "broadcast"  
15 paradigm, it will be understood that the various aspects of the present invention are equally applicable regardless of whether a given program is intended for broadcast or supplied via an on-demand (OD) or other such "user pull" service.

Referring now to Fig. 2, one exemplary embodiment of a network and head-end architecture useful with the present invention is described. As shown in Fig. 2, the head-  
20 end architecture 200 comprises typical head-end components and services including a billing module 202, subscriber management system (SMS) and CPE configuration management module 204, cable-modem termination system (CMTS) and OOB system 207, as well as LAN(s) 208, 210 placing the various components in data communication with one another. It will be appreciated that while a bar or bus LAN topology is  
25 illustrated, any number of other arrangements as previously referenced (e.g., ring, star, etc.) may be used consistent with the invention. It will also be appreciated that the head-end configuration depicted in Fig. 2 is high-level, conceptual architecture and that each MSO may have multiple head-ends deployed using custom architectures.

The architecture 200 of Fig. 2 further includes a multiplexer/encrypter/modulator  
30 (MEM) 212 coupled to the HFC network 201 adapted to "condition" content for transmission over the network, as subsequently described in detail herein with respect to Figs. 2a-2c. In the present context, the distribution servers 203 are coupled to the LAN 210, which provides access to the MEM 212 and network 201 via one or more file servers 220. VOD servers (not shown) may be coupled to the LAN 210 as well, although

other architectures may be employed (such as for example where the VOD servers are associated with a core switching device such as an 802.3z Gigabit Ethernet device).

As previously described, information is carried across multiple channels. Thus, the head-end must be adapted to acquire the information for the carried channels from various sources. Typically, the channels being delivered from the head-end 200 to the CPE 206 (“downstream”) are multiplexed together in the head-end and sent to neighborhood hubs (not shown).

Content (e.g., audio, video, etc.) is provided in each downstream (in-band) channel associated with the relevant service group, as subsequently described herein. To communicate with the head-end, the CPE 206 uses the out-of-band (OOB) or DOCSIS channels and associated protocols. The OCAP specification provides for networking protocols both downstream and upstream.

In another embodiment, the network infrastructure includes one or more on-demand file or “carousel” functions. Specifically, the present invention contemplates that not only will more traditional movie (e.g., MPEG) data be allocated and delivered through the bandwidth allocation mechanisms described herein, but also data for interactive applications or other types of applications. For example, in a fashion not unlike existing approaches to ordering an on-demand (OD) movie, an application would request data, images, links, audio files, video files, and the like in an on-demand fashion. These unique data types may comprise single files, or be combined into a single or multiple data carousels, with each carousel potentially having a different data rate. Upon receiving an OD service request, the allocation algorithm can optimize the placement of these sessions on QAM resources for delivery to the requestor. Hence, the OD downstream service can be considered a third and separate level of service (i.e., SD, HD, and OD), or alternatively can be considered as one or more subclasses within the existing levels; i.e., where SD includes SD-OD, and HD includes HD-OD.

Many other permutations of the foregoing system components and communication methods may also be used consistent with the present invention, as will be recognized by those of ordinary skill in the field.

Referring now to Fig. 2a, a first embodiment of the MEM apparatus 212 according to the invention is described. Shown in Fig. 2a are a plurality (e.g., 12) different HD streams or sources 231, which may comprise for example 12 distinct HD content programs, or even a transport stream comprising multiple programs. Hence, the term “program” is used herein to refer one or more individual content-based programs.

Each stream utilizes a given data compression rate (e.g., 12 Mbps) from the head-end to the CPE over the cable network. It will be appreciated that the representation of Fig. 2a comprises a logical representation only, i.e., the various HD sources 231 may be input on the same physical connection, on individual physical connections, or any combinations thereof.

Due to the maximum bandwidth limitation on each RF channel associated with the network, conventional techniques require that up to three HD programs can be multiplexed and transmitted on a single QAM carrier. According to an embodiment of the present invention, these 12 content programs are input to a "wideband multiplexer" 232 (see Fig. 2a). This multiplexer element 232 performs the function of quantization (as needed), and transfer of incoming packets to four target outputs 237 each being input to one of a bank 234 of four modulator/encryption units 240. It will be noted that while encryption and modulation functions are shown in a combined unit 240 in Fig. 2a, the implementation of the modulation and encryption functions can be performed separately or together as desired. See, e.g., Fig. 2b, wherein four separate modulation units 250 and encryption units 252 are utilized.

The baseband outputs of four (e.g., QAM) modulators 240 are then fed to a block upconverter 236 that upconverts the baseband signals (whether via an intermediate frequency (IF) or a "direct conversion" approach) and produces an output 238 from which each modulated QAM signal is assigned to an appropriate RF channel to be transmitted over the cable network 201. RF upconversion apparatus is well known in the art, and accordingly is not described further herein.

Similar to the modulators/encryptors 240 described above, the block upconversion process 236 may be performed using individual upconversion apparatus 256 if desired (see Fig. 2c). Furthermore, the upconversion apparatus can be combined with the modulation and/or encryption units 240 if desired.

It will also be recognized that the wideband multiplexing function 232 can be performed in two or more stages or using various aggregation schemes if desired. For example, in the context of Fig. 2a, the twelve sources 231 may be aggregated into, e.g., three groups of four (4), wherein a "local" or first-stage wideband multiplex function exists for each of the three groups, and the three multiplexed outputs of each group are then multiplexed using a second-stage wideband multiplexer. The statistical and control processes controlling the first and second stages of multiplexing may be logically coupled (such as via an interprocess communication mechanism of the type well known

in the art) or alternatively independent, depending on the desired result. A coupled set of multiplex stages may be used for example to provide “intelligent” HD program distribution across the various available RF channels based on downstream demand, upstream conditions, etc.

5           The MEM apparatus 212 may take any number of physical forms, comprising for example one of a plurality of discrete modules or cards within a larger network device of the type well known in the art, or even the cable modem termination system (CMTS). The MEM 212 may also comprise firmware, either alone or in combination with other hardware/software components such as those previously described. Alternatively, the  
10 MEM 212 may be a stand-alone device disposed at the head end or other location. Numerous other configurations may be used. The MEM 212 may also be integrated with other types of components (such as satellite transceivers, encoders/decoders, etc.) and form factors if desired.

Hardware within the MEM 212 included, e.g., digital processor(s), storage  
15 devices, and a plurality of data interfaces for use with other network apparatus such as IP routers and other packet network devices, network management and provisioning systems, local PCs, etc. Other components which may be utilized within the MEM 212 include amplifiers, board level electronic components, as well as media processors and other specialized SoC or ASIC devices. Support for various processing layers and  
20 protocols (e.g., 802.3, DOCSIS MAC, OOB channels, DHCP, SNMP, H.323/RTP/RTCP, VoIP, SIP, etc.) may also be provided as required. These additional components and functionalities are well known to those of ordinary skill in the cable and embedded system fields, and accordingly not described further herein.

In one embodiment, the MEM 212 features a statistical multiplexer function that  
25 is generally similar to an existing (“legacy”) rate shaper used in non-wideband applications. A software modification is utilized that allows for the rate shaper to output portions of the multi-program transport stream (MPTS) generated by the existing multiplexer to the different physical outputs 237. These outputs 237 feed the QAM modulators that apply encryption and feed the block upconverter as shown in Fig. 2a.

### 30 *N:M wideband multiplexing*

Unlike conventional stream multiplexing of the type shown in Fig. 1, wideband transport streams generally require multi-input, multi-output multiplexing. Fig. 3 shows an example functional block diagram of a multiplexer 232 that performs such a function. The Figure shows multiple content programs or streams 300 being input to a quantization

unit 302. In the following discussion, the number of input programs or streams 300 is denoted by "N". The N programs that comprise the input multiplex 300 could be derived from, e.g., one or more physical inputs; hence, the illustrated configuration is logical in nature. The quantization unit 302 is provided feedback 310 by the multiplexing stage 5 306, the feedback comprising information related to the instantaneous bandwidth available on each out-going transport multiplex. It should be noted that the separation and logical placement of the quantization function 302 and the multiplexing/encryption function 306 in the exemplary embodiment of Fig. 3 is purely illustrative; the two functions can be combined into a single function and/or integrated into the same 10 hardware, or alternatively could split across different logical stages.

Various rules defining how the total number "N" of input programs are mapped to "M" outputs (an N:M multiplexing scheme) can be implemented consistent with the present invention. For example, in one embodiment, a packet belonging to a particular input program or stream 310 can appear on any of the M outputs, depending on 15 implementation rules relating to one or more parameters such as instantaneous bandwidth availability (e.g., according to a "round robin" or other such scheme of the type well known in the art). Alternatively, a "most loaded" or "least loaded" type approaches can be utilized. See, e.g., U.S. Patent Application Serial No. 10/881,979 filed June 29, 2004 previously referenced herein.

20 Specifically, different multiplexing rules can be applied to different processes within the statistical multiplex. In one embodiment, a first decision is made regarding which packets to pull out of the "N" incoming program (packet) queues. A first rule could direct the algorithm to pull packets preferentially from those queues with the most packets. Alternatively, packets could be pulled out of the queues in a round-robin 25 fashion. In yet another implementation, packets could be transferred out of the queues by evaluating which packets arrived earliest at their corresponding program queue, and subsequently assigning bandwidth to the earliest-arrived packets.

A second decision is also made within the exemplary statistical multiplexer regarding which of the "M" available output carriers to assign those packets pulled out of 30 the input (program) queues to. This decision can also be made according to any number of algorithms, including for example round-robin, least-loaded or most-loaded.

Hence, the statistical multiplexing engine used within the wideband multiplexer 232 of the illustrated embodiment can utilize multiple related or independent processes in order to provide the desired statistical performance.

In another exemplary embodiment, packets from an input program can be constrained to appear on a smaller subset of the M outputs (e.g. only one or two outputs). One benefit of such a constraint is to create transport streams wherein some programs are simultaneously decodable by both legacy (i.e., non-wideband) CPE and the wideband  
5 CPE of the present invention.

This approach of imposing one or more constraints also advantageously aids in maintaining operability and compatibility during future wideband CPE deployments or upgrades. For example, a wideband CPE deployed with the capability to receive four QAM channels simultaneously via its single or multiple tuners (described subsequently  
10 herein) will be able to receive programming sent according to a "constrained" multiplex scheme on an eight-channel wideband signal in future deployments, if these programs are constrained to occupy four or less channels out of eight.

This approach also provides a migration path as newer, wider-band CPE are progressively introduced into an area. Specifically, in the context of the foregoing  
15 example, the downstream multiplex can be constrained to 4-channel wideband scheme for a period of time after the 8-channel CPE begins distribution with the service area of interest, thereby allowing for the eventual replacement of all 4-channel CPE with 8-channel CPE. This avoids situations where 4-channel CPE users are left "stranded" in a purely 8-channel programming environment.

The present invention further contemplates multi-mode operation; i.e., providing  
20 the head-end MEM 112 and the CPE 206 with the ability to vary their rule scheme (even dynamically) in order to accommodate changes in programming, system operability, maintenance, etc. For example, where an 8-channel CPE is receiving an 8-channel downstream multiplex, the CPE can be selectively switched to constrained 4-channel  
25 operation such as in response to loss of one of its channels (e.g., due to failure of the QAM modulator associated with that channel). This switching can be according to a preprogrammed pattern or rule, or may be conducted dynamically based on, e.g., a "constraint" algorithm, so long as the affected CPE and head-end are in communication or otherwise apply a similar algorithm at the same time.

30 Similarly, rules-based input-output mapping also is helpful if changing channel conditions change the available bandwidth on one or more carriers over the duration of program transmission.

*PID Re-mapping, Reordering, and Table Generation*

Depending on the rules of implementation of the N:M wideband multiplexer 306, each of the M outputs individually may or may not be compliant with various broadcast and cable television transmission standards. In one embodiment, a packet ID (PID) remapping and table generation stage within the MEM 212 allows system operator to set the level of compliance by controlling generation of program-specific information (PSI) tables (e.g., PAT and PMT), System Information (SI) tables and other features such as PID remapping, deciding which tables to send on which QAM carrier, and so forth. In an exemplary embodiment of the invention, the PID remapping/ table generation function is implemented as a software process within the quantization unit 302 of Fig. 3 (i.e., prior to multiplexing), such that PSI and any other SI tables have to be generated only once. Packets belonging to a single SI or PSI table could appear on different inputs at the output of the quantizer 302.

In one embodiment of the head-end multiplexing apparatus 212 of the invention, each of the individual M outputs created by the multiplexers 306 can comprise a fully compliant MPEG stream. In another embodiment, the M output streams are combined together to form a compliant MPEG transport stream, but may not be compliant individually. Other schemes will also be recognized by those of ordinary skill provided the present disclosure.

*Exemplary CPE and Tuning*

Figs. 4 and 4a illustrate a first embodiment of the improved wideband CPE 206 according to the present invention. As shown in the simplified diagram of Fig. 4, the device 206 generally comprises an OpenCable-compliant embedded system having an RF front end 402 (including tuner, demodulator/decryptors, and demultiplexer as discussed with respect to Fig. 4a below) for interface with the HFC network 201 of Fig. 2, digital processor(s) 404, storage device 406, and a plurality of interfaces 408 (e.g., video/audio interfaces, IEEE-1394 "Firewire", USB, serial/parallel ports, etc.) for interface with other end-user apparatus such as televisions, personal electronics, computers, WiFi or other network hubs/routers, etc. Other components which may be utilized within the device (deleted from Fig. 4 for simplicity) various processing layers (e.g., DOCSIS MAC or DAVIC OOB channel, MPEG, etc.) as well as media processors and other specialized SoC or ASIC devices. These additional components and

functionality are well known to those of ordinary skill in the cable and embedded system fields, and accordingly not described further herein.

The device 206 of Fig. 4 is also provided with an OCAP 1.0-compliant application and Java-based middleware which, *inter alia*, manages the operation of the device and applications running thereon. It will be recognized by those of ordinary skill that myriad different device and software architectures may be used consistent with the wideband tuning and demultiplexing functions of the present invention, the device of Fig. 4 being merely exemplary. For example, different middlewares (e.g., MHP, MHEG, or ACAP) may be used in place of the OCAP middleware of the illustrated embodiment.

Fig. 4a illustrates one exemplary embodiment of the RF front end 402 of the CPE 206 of Fig. 4. The front end 402 includes a wideband tuner 420 (which may comprise for example a single wideband tuner such as the WBR device manufactured by Broadlogic Network Technologies, or a plurality of individual tuners effectively aggregated to provide wideband tuner functionality), one or more QAM demodulators and decryptors 422 (which may be separate or integrated devices as previously discussed with respect to the head-end apparatus), and a transport stream demultiplexer (and jitter compensator) 424. A decoder stage 426 is also provided at the (logical) output of the demultiplexer 424, such as for example an MPEG2 decoder of the type well known in the art.

As is well known, the decryption stage of an authenticated CPE 206 performs unscrambling of the program of interest by using appropriate key stream. In the illustrated embodiment, the decryption function is implemented together with the demodulators 422. Therefore, packets of a wideband content program will be decrypted in the multiple decryption engines within the modules 422 and subsequently demultiplexed back together for decoding purposes. However, other arrangements may be used, such where the decryption stage is implemented after the demodulation 422 and the de-multiplexing/jitter compensation 424 is completed.

As previously noted, it is desirable that the present embodiment of the wideband CPE 206 operate in both wideband multiplexed and legacy deployments. To receive a desired program using legacy CPE, the CPE must be able to tune to receive to the appropriate RF channel, demodulate the received signal, decrypt the demodulated signal if needed, de-multiplex the demodulated and decrypted multiplex, and finally decode the appropriate program. The information regarding which RF channel to tune to for receiving a program is found typically in program information tables that are repeatedly

sent either within the same transport stream or in another adjoining packet stream sent to the CPE.

For example, in CPE implementing the OpenCable™ standard, such translation from the desired program channel to the actual tuning details can be performed using special descriptors contained within the program-specific information (PSI); including  
5 e.g., PAT or PMT. In one variant, the cross-references or mapping is defined within the PMT. In another embodiment, the correlation between the desired program and the tuning details is performed using information contained in the Event Information Tables (EITs). Other approaches may also be used with equal success.

10 For wideband tuning, the exemplary CPE 206 of the present invention uses a mechanism somewhat similar to the aforementioned tuning mechanism. The tuning procedure is advantageously assisted in the exemplary embodiment of Fig. 4a by imposing the requirement that all table formats are kept substantially consistent with those present in legacy systems. A given content program is indicated as a wideband  
15 program if it requires simultaneous demodulation of multiple RF carriers. In another table entry, the number of channels ( $M$ ) that the program is spread over is provided. Once the CPE 206 decodes this number, it can then search for the exact QAM channel frequencies used for wideband modulation of this program, through yet another entry in a table. In one variant of this information scheme, all  $M$  channels over which the  
20 program is spread are listed. In another variant, the  $M$  channels are selected so as to be contiguous, and the table utilizes a syntax indicating a starting (or terminus) point and another field corresponding to the number of contiguous channels (e.g., “ $M$  contiguous channels starting at [starting point]”, or “ $M$  contiguous channels up to and including [terminus]”). These latter approaches economize the downstream transmission of table  
25 bits.

An exemplary embodiment of the program tuning logic according to the invention is shown in Fig. 5. When the CPE 206 is made to tune to a particular program, it first determines whether the program to which it has tuned is a wideband program (step 502). If the program is not wideband (as determined by, e.g., a table entry and/or other  
30 prescribed format as discussed above), the algorithm proceeds with conventional tuning steps (504). If the program is determined to be wideband in nature, the CPE makes sure that the wideband program is within its decoding capability (step 506). If the program cannot be decoded, then feedback is provided to the user (e.g., an “unable to decode” message displayed on the user’s display device), and/or transmitting entity (such as via

an upstream OOB channel) via step 508. If the program is decodable, tuning channel information for the program is extracted and parsed per step 510. Additional processing is then conducted per step 512, such additional processing comprising any number of different steps necessary to further decode and display the decoded content as is known to those of ordinary skill.

#### *Packet Jitter, Delay and Reordering*

It is possible for packets belonging to the same program or content stream to reach the CPE 206 by traveling over different physical carriers (i.e., a logical channel established over multiple physical channels, akin to ATM VPI/VCI), leading to a situation where these packets are received out-of-order or in a shuffled manner at the CPE. In one embodiment of the invention, a packet re-ordering function is implemented in the CPE 206. One variant of this reordering function comprises using a continuity counter (CC) field in the header of the bits of the MPEG header portion of the packets. This approach advantageously makes use of existing protocol structures, thereby obviating the addition of more packet overhead or other mechanisms. However, it will be appreciated that the packet reordering process of the invention is not inherently dependent on the MPEG CC field; many other transport protocols provide packet counter in header field that enable such packet reordering. Furthermore, other mechanisms for packet management can be employed along with reordering, such as use of jitter compensation (e.g., jitter buffer) described below or the like which, *inter alia*, sets outer bounds on the latency of late-arriving packets.

In general, the modulation parameters used for each of the M channels in a wideband multiplex may not be same. This poses the additional complication to the CPE 206 that packets may undergo unequal delay from input to the multiplexer on the head-end side to the output of the demultiplexer 424 on the CPE side. In some applications, CPE implementations will want to remove this timing jitter within a content program. Depending on variables such as the constellation used for a carrier, the end-to-end delay for packets could be different. The de-jittering operation can be performed using any number of different approaches, such as by inspecting the packets for embedded timestamps within the packets to indicate their degree of jitter (e.g., relative to a system or SI clock or other time reference). The jitter compensator 424 of the present invention may also employ analysis of the modulation characteristics of each QAM carrier within the wideband multiplex in relation to the extracted timing information to make dynamic adjustments of the jitter compensator (and/or even the relevant modulator/demodulator

itself). It will be appreciated that from the broader perspective, a timing correction function at the receiving end (e.g., CPE 206) that extracts the relevant timing information and compensates for any jitters is useful in meeting real time specifications for digital audio/video programs.

#### 5 *Implementation in Edge QAM*

In certain applications, cable system operators may use so-called "Gigabit Ethernet" (GBE) or a similar data infrastructure and protocol for transporting audio/video content in the core network (that is, between the head-end and the network hubs). Therefore, the hubs may be used as the location where digital television signals are modulated to QAM channels. The architectural device that performs this function is commonly referred to an "Edge QAM" device. At the Edge QAM device, packets belonging to a given content program are selected from the input (e.g., Gigabit Ethernet) interface and transferred to the desired output port.

Hence, in alternate embodiments of the present invention, aspects of the HD statistical multiplex implemented at the cable system head-end 200 of Fig. 2, such as QAM modulation, can be implemented at the Edge QAM, or alternatively all of the required functionality (e.g., multiplexing, modulation and encryption) can be implemented at the Edge device. Fig. 6 illustrates one exemplary embodiment of a system 600 wherein the head-end 602 is coupled via, e.g., an optical fiber network 604, to an optical receiver 606 and ultimately an Edge QAM 608. The optical network may comprise, e.g., a dense wave division multiplexing (DWDM), O/FDM, or similar approach. The optical receiver de-multiplexes the optical "transport stream", and provides this data via, e.g., a GBE interface or Asynchronous Serial Interface (ASI), to the Edge QAM device 608, which modulates the signal onto the various carriers 610 of the cable (RF) portion of the network.

It will be appreciated that literally any type of medium (or in fact multiple types of mediums in serial or parallel) can be interposed between the head-end 602 and the Edge QAM 608. Furthermore, the use of multiple homogeneous or heterogeneous edge devices is contemplated, such as for example where one configuration of Edge QAM is used at all hubs, or alternatively where a first configuration is used at one distribution hub, while another configuration is used at another hub. Furthermore, the network as a whole can be hybridized or heterogeneous, such as where portions of a given service

region are served by an architecture akin to that of Fig. 2a, and others served by an architecture akin to that of Fig. 6 (see Fig. 6a).

It is further noted that the foregoing reference to GBE systems is purely illustrative; for example, asynchronous transfer mode (ATM) backbones or other types of networks/protocols may be used as the preferred medium between various of the network's architectural elements.

It can also be appreciated that the methods of the present invention may be practiced using any configuration or combination of hardware, firmware, or software, and may be disposed within one or any number of different physical or logical entities. For example, the HD wideband multiplex functionality described above may take the form of one or more computer programs running on a single device disposed within the network (e.g., the MEM 212 previously described), such as at a head-end, node, or hub. Alternatively, such computer programs may have one or more components distributed across various hardware environments at the same or different locations. As yet another example, portions of the functionality may be rendered as a dedicated or application specific IC having code running thereon. Myriad different configurations for practicing the invention will be recognized by those of ordinary skill in the network arts provided the present disclosure.

#### 20 *Wideband Stagger-cast*

It will be recognized that the wideband apparatus and methods of the present invention can also be used to afford other benefits, including increased HD density and near-VOD (NVOD) capability. Specifically, in one embodiment, programming is "stagger-cast" such that time-shifted copies of a given high video quality (e.g., HD) program are transmitted over the wideband multiplex. Stagger-cast is a process wherein identical copies of the same program, with their start times staggered by some duration, are multiplexed with each other to form a transport stream. When a viewer tunes to the transport stream, the viewer can start watching the program from the beginning as soon as the start of a next staggered copy of the program is received. This results in a VOD-like functionality without having to wait for a long period of time (e.g., until the next scheduled iteration of the complete movie, such as the next 2-hour slot). For example, twenty-four copies of a movie of 120 minutes duration can be staggered to start 5 minutes apart in a single cable QAM channel, with each copy being assigned

approximately 1.2 Mbps bandwidth. When the viewer tunes into such a multiplex, he is never more than 5 minutes away from starting point of a copy of the program.

As noted above, each time-shifted version of the program comprises a different broadcast. Thus, the MSO can provide the user with a near-VOD capability, with the  
5 level of latency (i.e., how “near” the NVOD really is to true VOD, such as the 5 min. referenced in the above example) being determined by the metrics of the time delay and wideband multiplex.

It will be appreciated that there is a trade-off between the aforementioned latency versus and the number of copies of the same program that are multiplexed together. For  
10 example, the above exemplary stagger-cast stream could also be constructed using 12 copies of the program, staggered to start 10 minutes apart. Therefore, if a service provider wants to offer to the viewers a service that reduces the wait or latency of a given point in the program being again accessible, more copies of the programs will have to be multiplexed together.

15 If a stagger-cast technique is to be applied to high quality programs (such as HD programs) at the typical 12-18 Mbps compression rate, only about 3 copies can be stagger-cast together. However, when a wideband multiplex such as that of the present invention is used, there is additional bandwidth available to include more copies, thereby reducing the wait time or latency experienced by the viewer. As an example, in a  
20 wideband multiplex consisting of four QAM channels, 12 copies of an HD program of 120 minutes duration each can be stagger-cast, assuming 12 Mbps each, with the resultant wait time being less than 10 minutes.

Therefore, the use of a wideband multiplex according to the invention advantageously overcomes the limitation of offering multiplexed HD stagger-cast  
25 programming in a single multiplex, and offers a system operator the ability to provide high quality stagger-cast near-VOD services with minimal user wait time.

Use of the wideband tuner of the present invention also provides additional benefits in that it avoids the “tuning away” from a single physical channel as in the prior art (non-wideband) systems, thereby making the stagger-cast implementation more  
30 efficient. Specifically, the user can access stagger-cast copies of the program by simply accessing the wideband multiplex at a given stagger time coordinate, and hence no additional tuning to a different simulcast/stagger-cast channel is required.

### *Business Methods*

In another aspect of the invention, the foregoing “wideband” head-end, Edge, and CPE capabilities can be used to implement various business paradigms. As previously discussed, the migration of a given service area or subset of users to newer (wideband) CPE can be performed in a controlled fashion which does not strand any users or forcibly  
5 require them to upgrade to the newer CPE or face losing service.

However, additional business models are envisaged, including for example selectively providing the upgraded or wideband CPE to a subset of users/subscribers (whether on a fee basis, as a promotion, or for free) as a “premium” feature. As previously discussed, with two or more operating modes (such as, e.g., 8 QAMs, 4  
10 QAMs, and 2 QAMs) for the wideband receiver, and changes between the modes being essentially seamless, the subscriber is provided with enhanced reliability and continuity during periods of equipment failure, maintenance, or mode-shifting at the head-end in response to changing program conditions. For example, with a single-QAM prior art CPE, loss of that single QAM means (at least temporary) loss of the HD or other content  
15 streamed over it. In contrast, loss of a single QAM in an eight QAM wideband system reduces the QAM pool for the head-end multiplexer, in effect forcing a mode shift (e.g., to four QAMs, where the four QAMs do not include the lost QAM). This shift can be seamless, such as via a simple in-band or OOB downstream communication telling the CPE when and which mode to shift to. The head-end and CPE can also be configured  
20 with “QAM packages”, or predetermined sets of particular QAMs, such that the head-end need merely transmit the QAM package number to the CPE. Alternatively, the QAM packages can be programmatically shifted-to under certain operational conditions, such as maintenance, etc.

It will also be appreciated that the user or subscriber can be provided a financial  
25 or other incentive to install the wideband CPE (as to replace their existing legacy CPE), since the greater the permeation of the wideband CPE in a given service area, the greater the benefits to the MSO or provider in terms of statistical multiplexing efficiency for HD programs. Consider, for example, the limiting case of where the wideband statistical multiplexer (MEM 212) described in Fig. 2 is in communication with an installed CPE  
30 pool comprising only legacy (non-wideband) CPE. The benefits of the wideband MEM 212 are hence totally frustrated, since the MEM can only use a single QAM to communicate with each CPE. However, at the other limit (i.e., all installed CPE are wideband CPE), the full benefits of the multiplexing approaches described herein can be realized. Hence, there is financial incentive to the MSO to get as many wideband CPE

installed as possible, and one possible way to accomplish this is to pay subscribers, or offer discounts or other incentives, to make the trade.

It will be recognized that while certain aspects of the invention are described in terms of a specific sequence of steps of a method, these descriptions are only illustrative  
5 of the broader methods of the invention, and may be modified as required by the particular application. Certain steps may be rendered unnecessary or optional under certain circumstances. Additionally, certain steps or functionality may be added to the disclosed embodiments, or the order of performance of two or more steps permuted. All such variations are considered to be encompassed within the invention disclosed and  
10 claimed herein.

While the above detailed description has shown, described, and pointed out novel features of the invention as applied to various embodiments, it will be understood that various omissions, substitutions, and changes in the form and details of the device or process illustrated may be made by those skilled in the art without departing from the  
15 invention. The foregoing description is of the best mode presently contemplated of carrying out the invention. This description is in no way meant to be limiting, but rather should be taken as illustrative of the general principles of the invention. The scope of the invention should be determined with reference to the claims.

What is claimed is:

1. Customer premises equipment (CPE) configured to receive transmitted content substantially simultaneously from a plurality of information carriers present on a plurality of radio frequency (RF) channels, said CPE comprising:

a tuner stage configured to receive first signals simultaneously from said plurality of information carriers;

a demodulator stage configured to demodulate a plurality of said first signals;

a decryption stage configured to decrypt at least a portion of said demodulated signals;

and

content reassembly apparatus operatively coupled to said decryption stage, said content reassembly apparatus configured to reassemble said decrypted and demodulated signals into said transmitted content;

wherein said tuner stage is further configured to receive both (i) a first program information table entry comprising a number of said plurality of RF channels over which said first signals are received, and (ii) a second program information table entry that identifies one or more frequency bands configured to be used by said first signals; and

wherein said CPE is further configured to dynamically search for particular ones of said one or more frequency bands corresponding to said first signals, based on said first and second program information table entries.

2. The CPE of Claim 1, wherein said content reassembly apparatus provides a plurality of packets in order.

3. The CPE of Claim 2, wherein said order is determined based on a continuity counter associated with one or more Moving Picture Experts Group (MPEG) streams.

4. The CPE of Claim 1, wherein at least a portion of said demodulated and decrypted signals comprise Moving Picture Experts Group (MPEG) packets, and said content reassembly apparatus provides for a timing correction of at least a portion of said MPEG packets.

5. The CPE of Claim 4, wherein said timing correction is performed based at least in part on information relating to a modulation scheme of each of said carriers.

6. The CPE in Claim 1, wherein said decryption is accomplished via a substantially independent decryptor apparatus on a per-carrier basis.

7. The CPE of Claim 1, wherein at least a first and second of said plurality of RF

channels are separated by at least one third RF channel.

8. A method of providing cable network services to a service area having a first customer premises equipment (CPE) installed therein, said first CPE being configured to receive at least one program over a first number of channels of said cable network, said method comprising:

providing a second CPE to a first portion of said service area, said second CPE being configured to receive said at least one program over a second number of channels of said cable network;

transmitting said at least one program over said first number of channels to said service area for a first period of time;

providing said second CPE to a second portion of said service area;

transmitting said at least one program over said second number of channels to said service area thereafter;

removing said first CPE from said service area; and

removing one or more channels associated with said first number of channels, said one or more channels being used only by said first CPE.

9. The method of Claim 8, wherein said first CPE comprises a legacy CPE, said first number of channels comprises one (1), said second CPE comprises a wideband CPE, and said second number of channels comprises a number greater than one (1).

10. The method of Claim 8, wherein said first CPE comprises a wideband CPE, said first number of channels comprises a number greater than one (1), said second CPE comprises a second wideband CPE, and said second number of channels comprises a number greater than said first number of channels.

11. The method of Claim 10, wherein said transmitting said at least one program over said first number of channels to said service area for said first period of time comprises constraining a wideband multiplex to a subset of said second number of channels.

12. The method of Claim 11, wherein said subset is a number less than or equal to said first number of channels.

13. A method of operating a customer premises equipment (CPE) within a cable network comprising a plurality of legacy-capable CPE and a plurality of wideband CPE operatively coupled thereto, said method comprising:

receiving a plurality of programs comprising a plurality of packets, said receiving comprising receiving said plurality of packets over multiple carriers of said network; and

extracting program information data as part of said receiving such that one or more of said plurality of wideband CPE can decode said plurality of programs, said program information data comprising a value which indicates a number of said multiple carriers over which said plurality of packets are spread so as to enable simultaneous demodulation of said plurality of programs, said spreading of said plurality of packets over said number of said multiple carriers precluding said legacy-capable CPE from decoding said plurality of programs, said legacy-capable CPE being configured to decode only non-spread programs;

wherein said cable network is configured to cause transmission of selected ones of said plurality of programs to be constrained to a subset of said multiple carriers of said network based at least in part on a failure of one or more of said multiple carriers during a distribution of said plurality of programs.

14. The method of Claim 13, wherein said extracting program information data comprises:

using an object-oriented computer program resident on said wideband CPE to extract said program information data; and

decoding said at least one first program based at least in part on said extracted program information data.

15. The method of Claim 13, further comprising extracting program information data such that at least one second program sent in a legacy format can be decoded by both said legacy-capable CPE and said wideband CPE.

16. The method of Claim 14, wherein said first program comprises an encrypted stream.

17. The method of Claim 15, wherein said program information data comprises a virtual service defined to have multiple physical carriers.

18. Wideband customer premises equipment (CPE) configured to operate within a cable network also having legacy CPE operatively coupled thereto, said wideband CPE comprising:

radio frequency (RF) tuner apparatus configured to receive at least one first program comprising a plurality of first content elements, and also at least one second program comprising a plurality of second content elements, said RF tuner apparatus configured to receive said first and second content elements over multiple carriers of said network; and

data processing apparatus configured to extract program information data as part of said receipt of said at least first and second content elements such that said wideband CPE

can decode both said at least one first program and said at least one second program;

wherein said extracted program information is structured so as to preclude said legacy CPE from decoding said at least one first program;

wherein said RF tuner apparatus is further configured to receive both (i) a first program information table entry comprising a number of a plurality of RF channels over which said plurality of first content elements are received, and (ii) a second program information table entry that identifies one or more frequency bands configured to be used by said plurality of first content elements; and

wherein said wideband CPE is further configured to dynamically search for particular ones of said one or more frequency bands corresponding to said plurality of first content elements, said dynamic search being based on said first and second program information table entries.

19. The wideband CPE of Claim 18, wherein said RF tuner apparatus comprises a plurality of tuners configured to receive with a frequency band which is less than a total frequency band of said multiple carriers.

20. The wideband CPE of Claim 18, wherein said RF tuner apparatus comprises a unitary tuner configured to receive with a frequency band which is at least as large as a total frequency band of said multiple carriers.

21. The wideband CPE of Claim 18, wherein said wideband CPE is configured to operate in at least first and second modes, said first mode comprising receipt of content elements over a first number of said multiple carriers, said second mode comprising receipt of content elements over a second number of said multiple carriers, said first and second numbers being different.

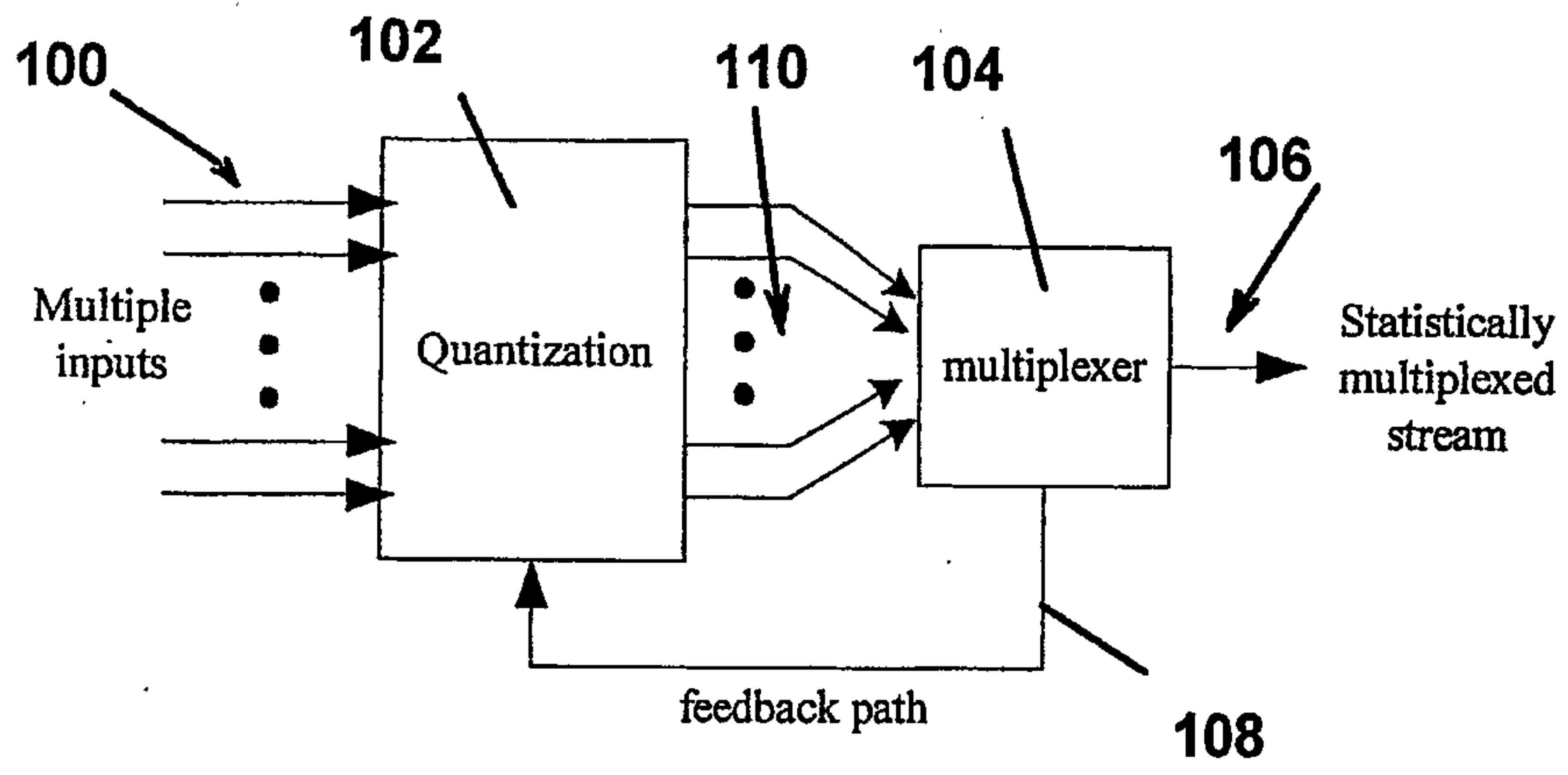
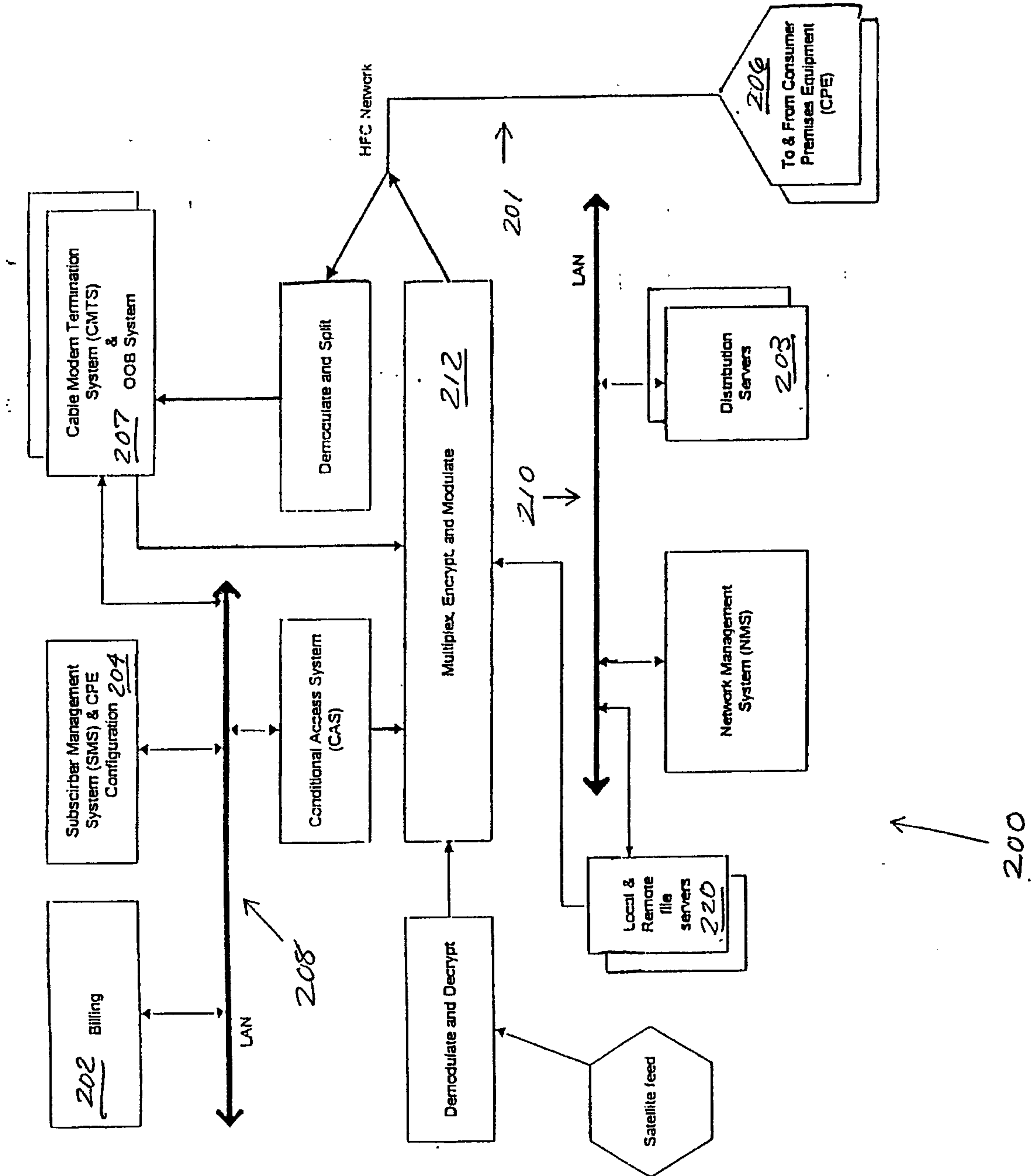

Fig. 1 (Prior Art)

FIG 2



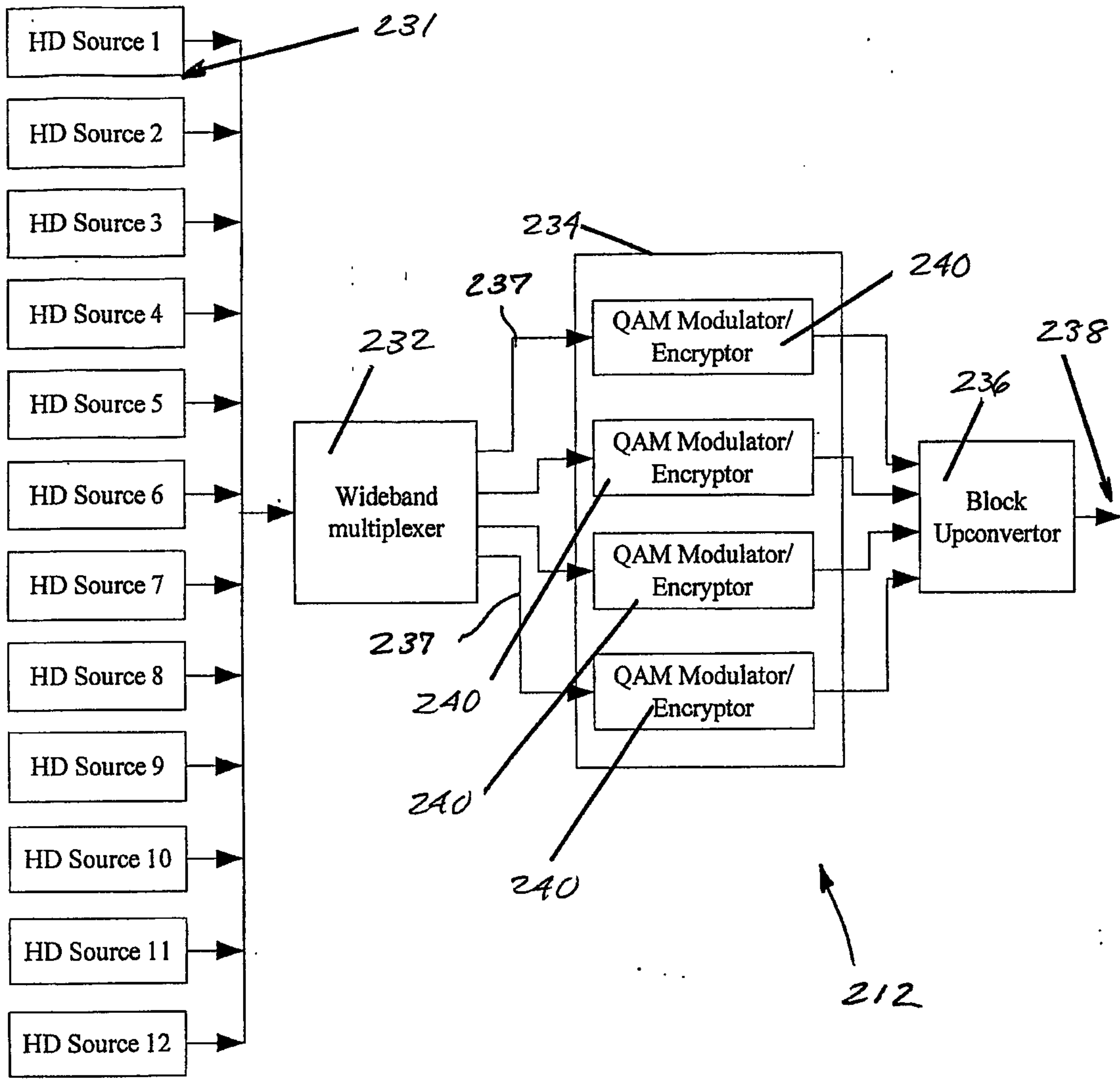

FIG. 2a

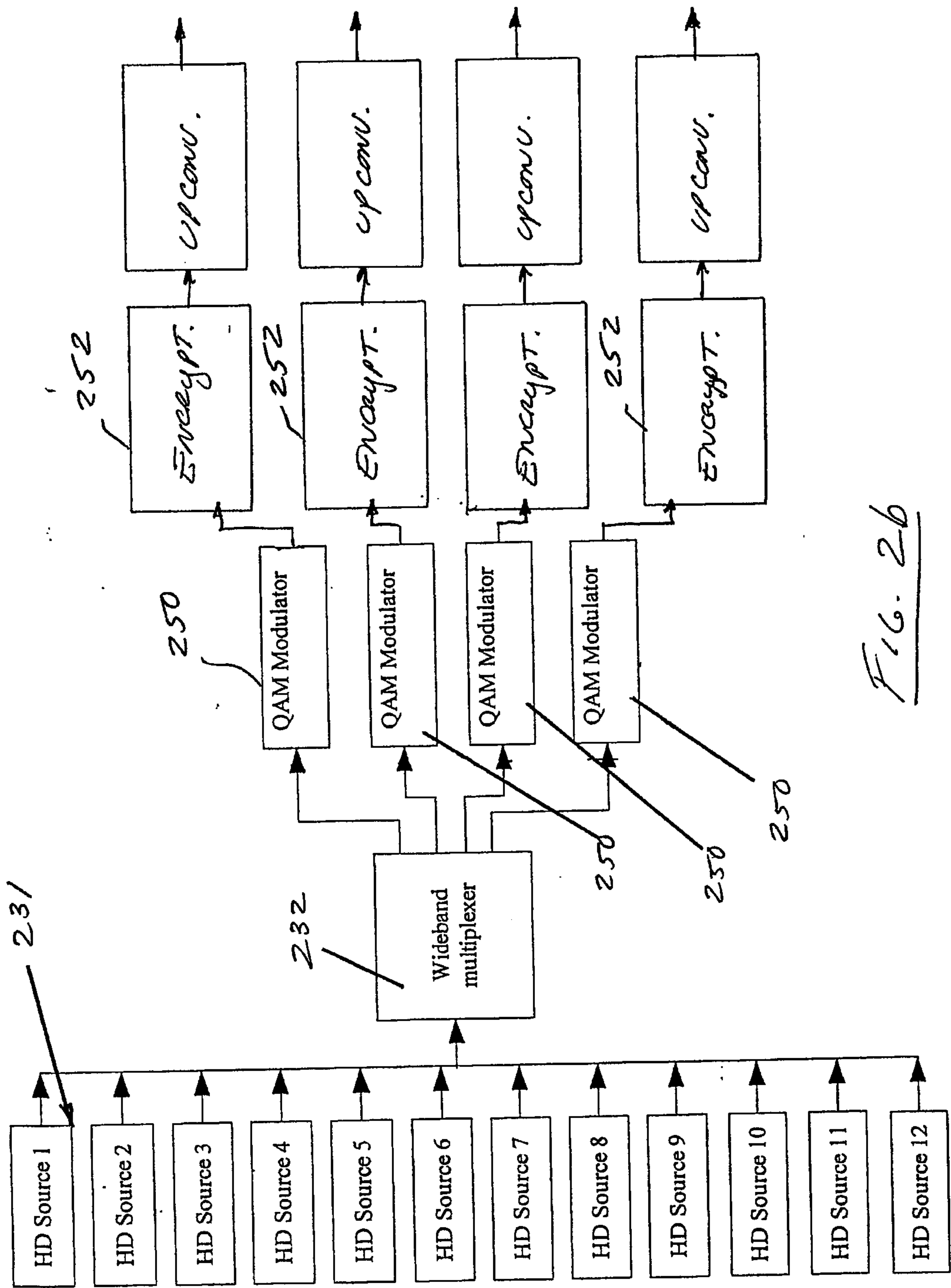
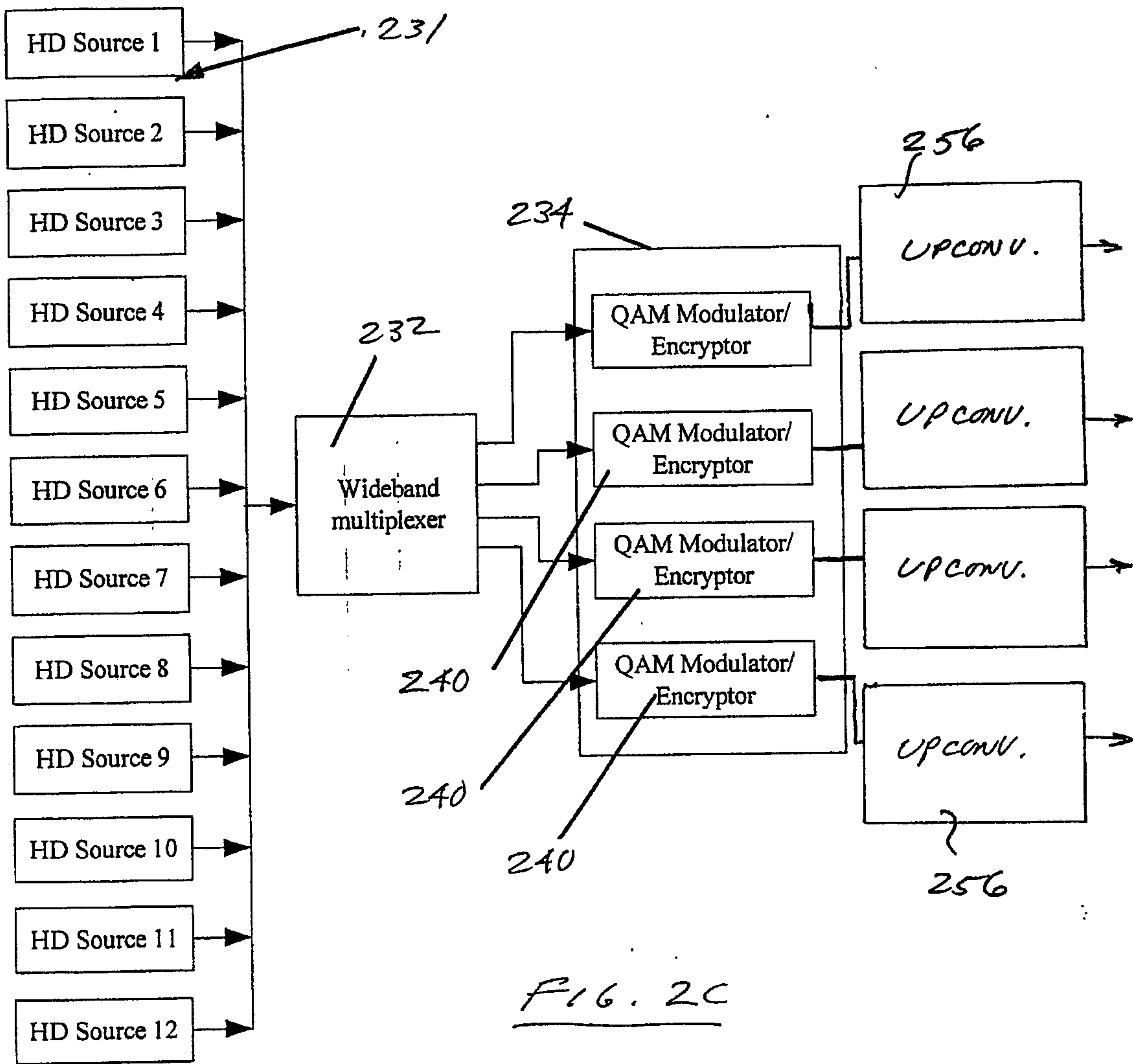

FIG. 2b



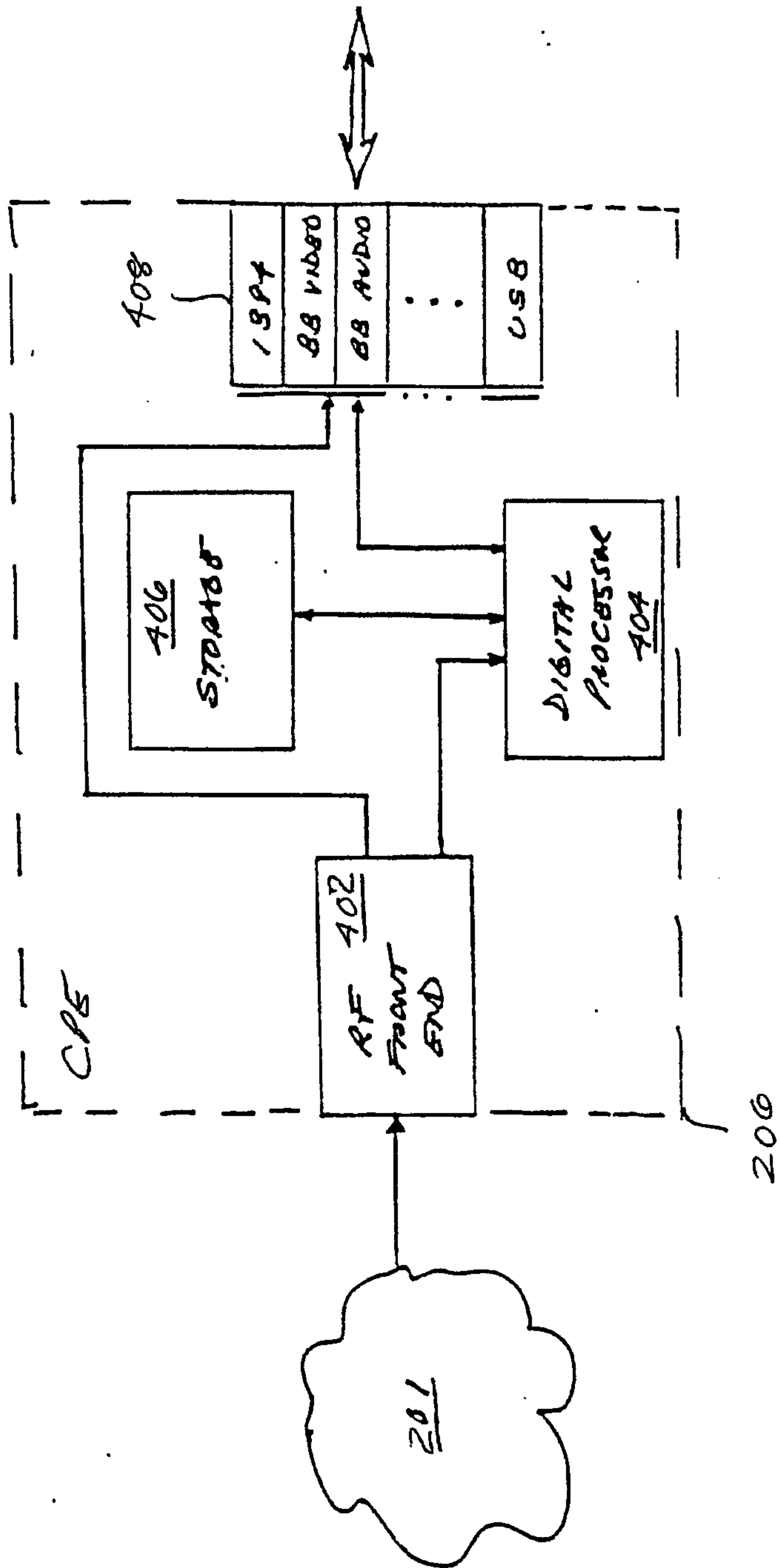

FIG. 4

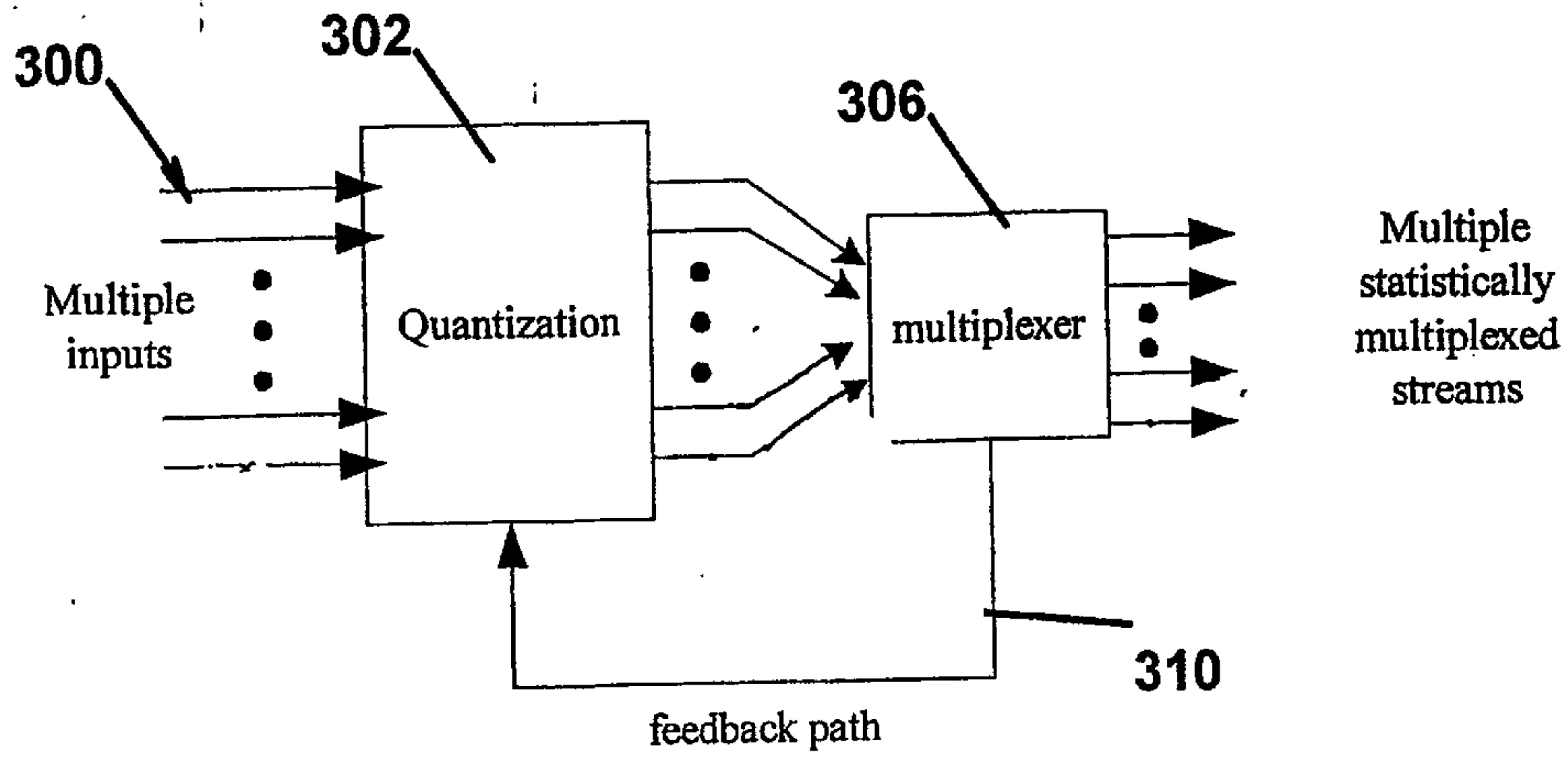
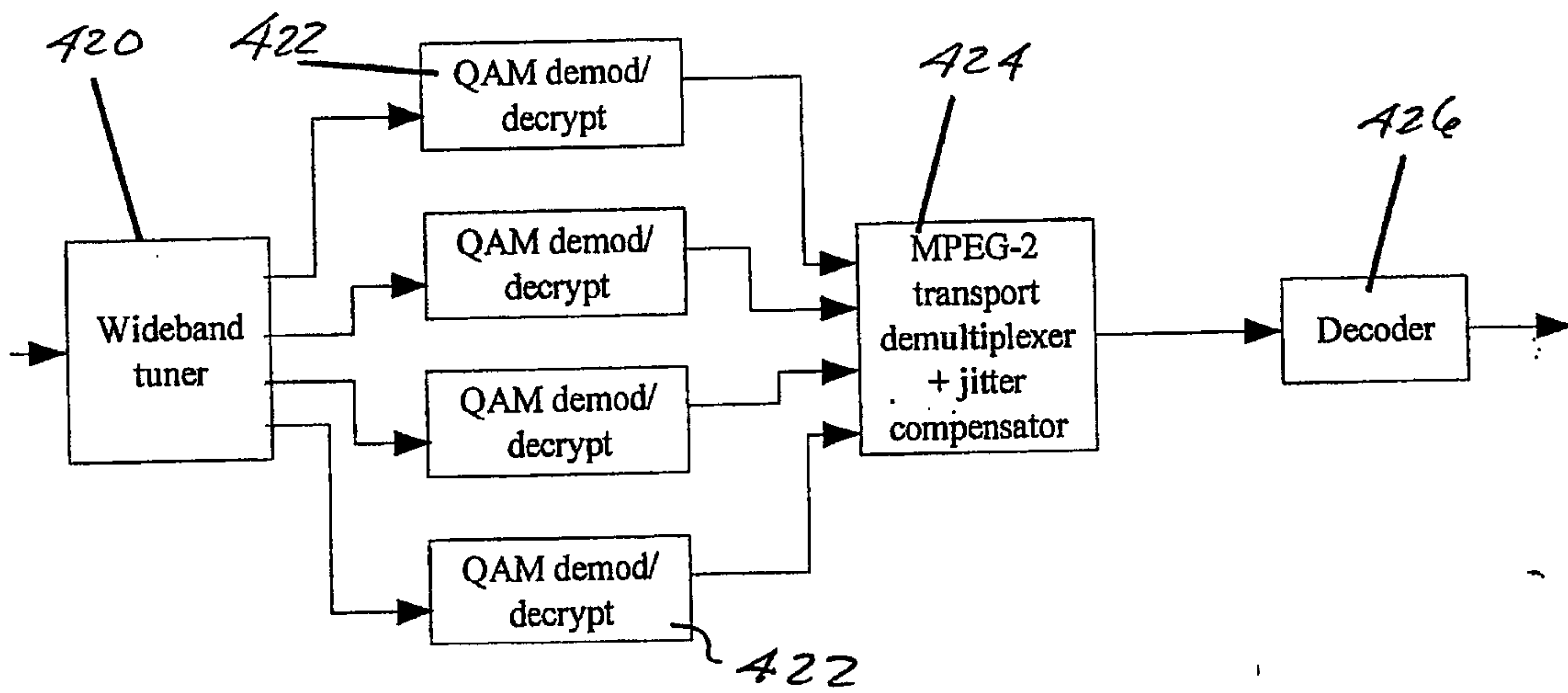

Fig. 3



402

Fig. 4a

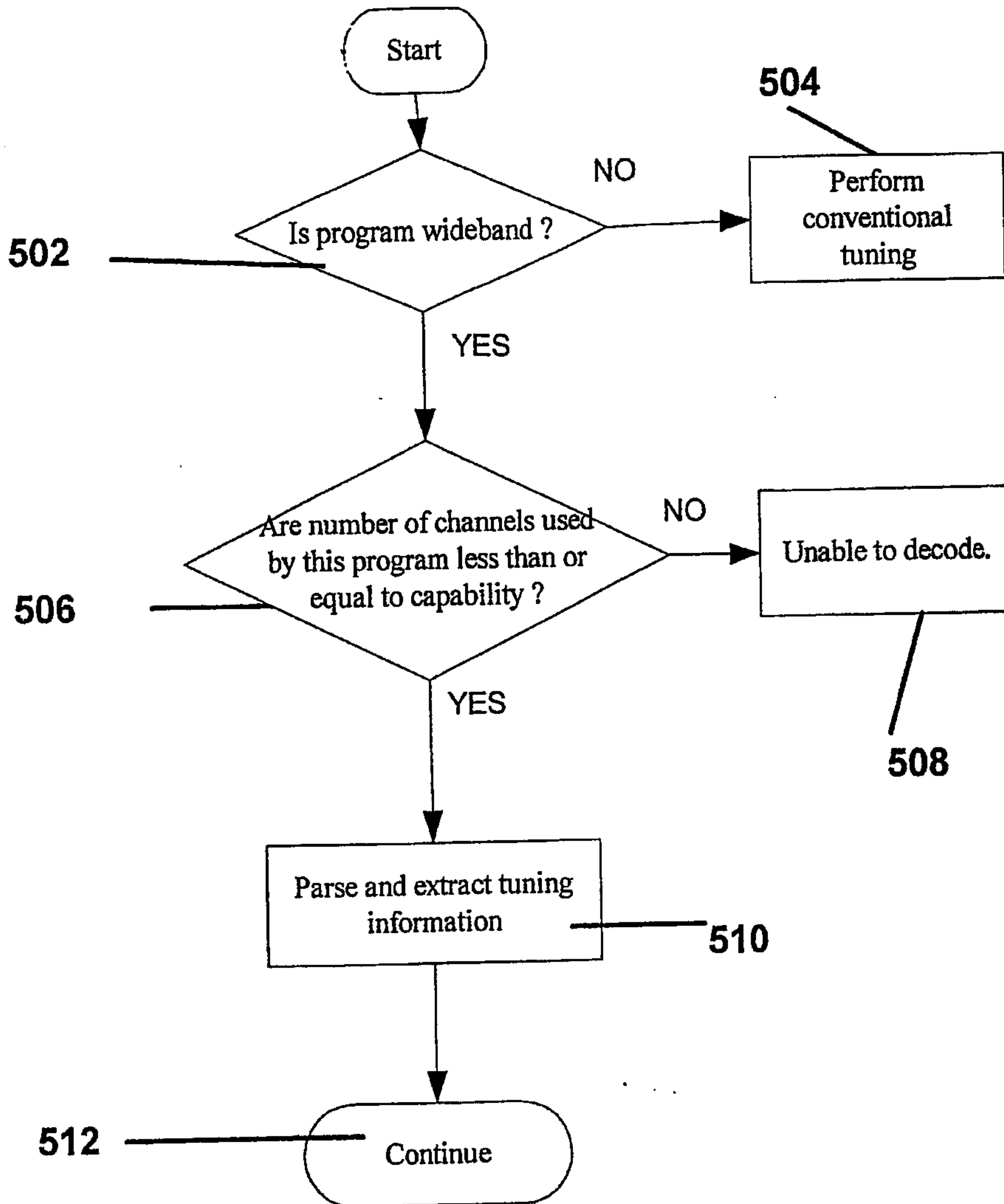

Fig. 5

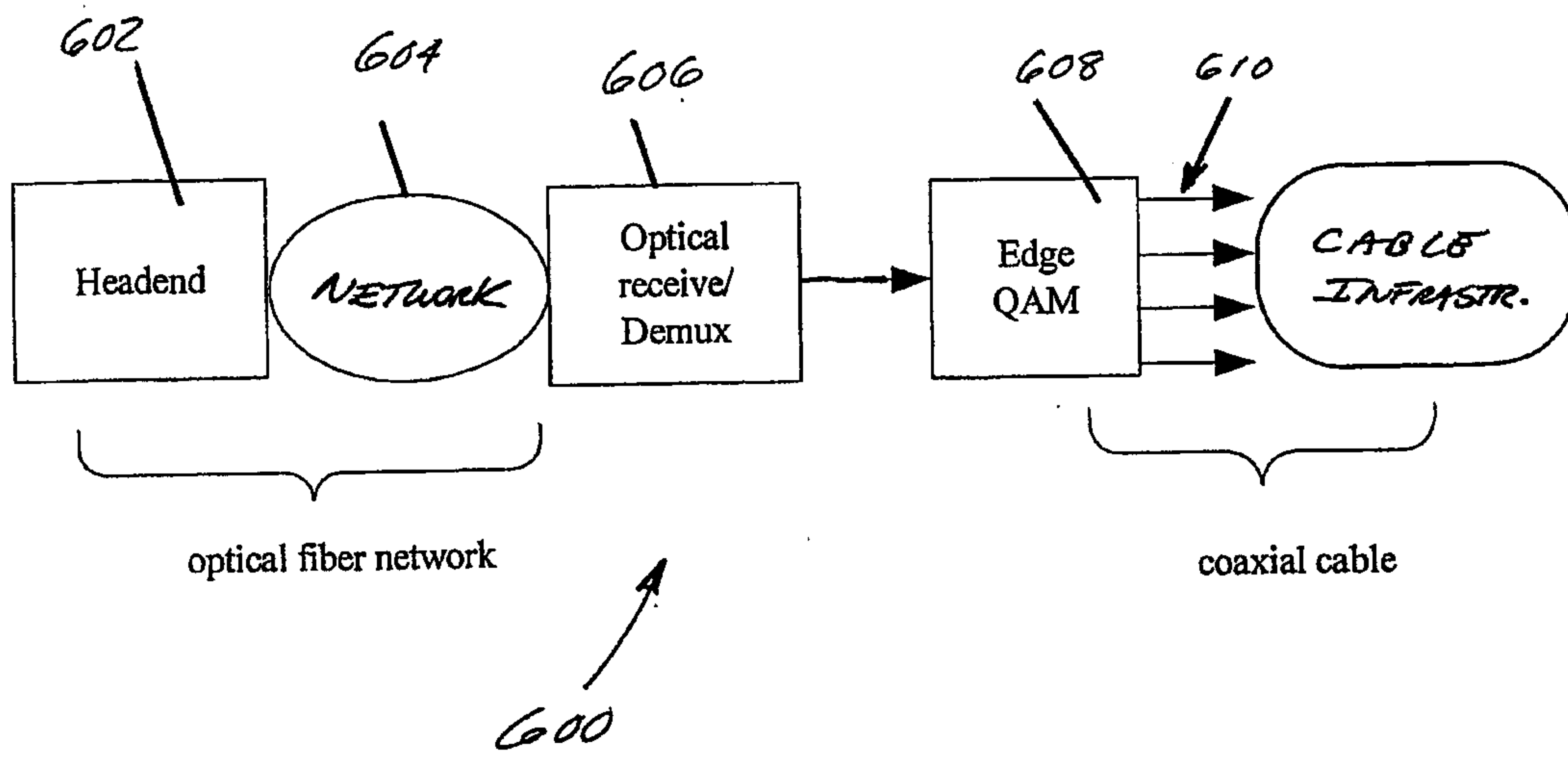

Fig. 6

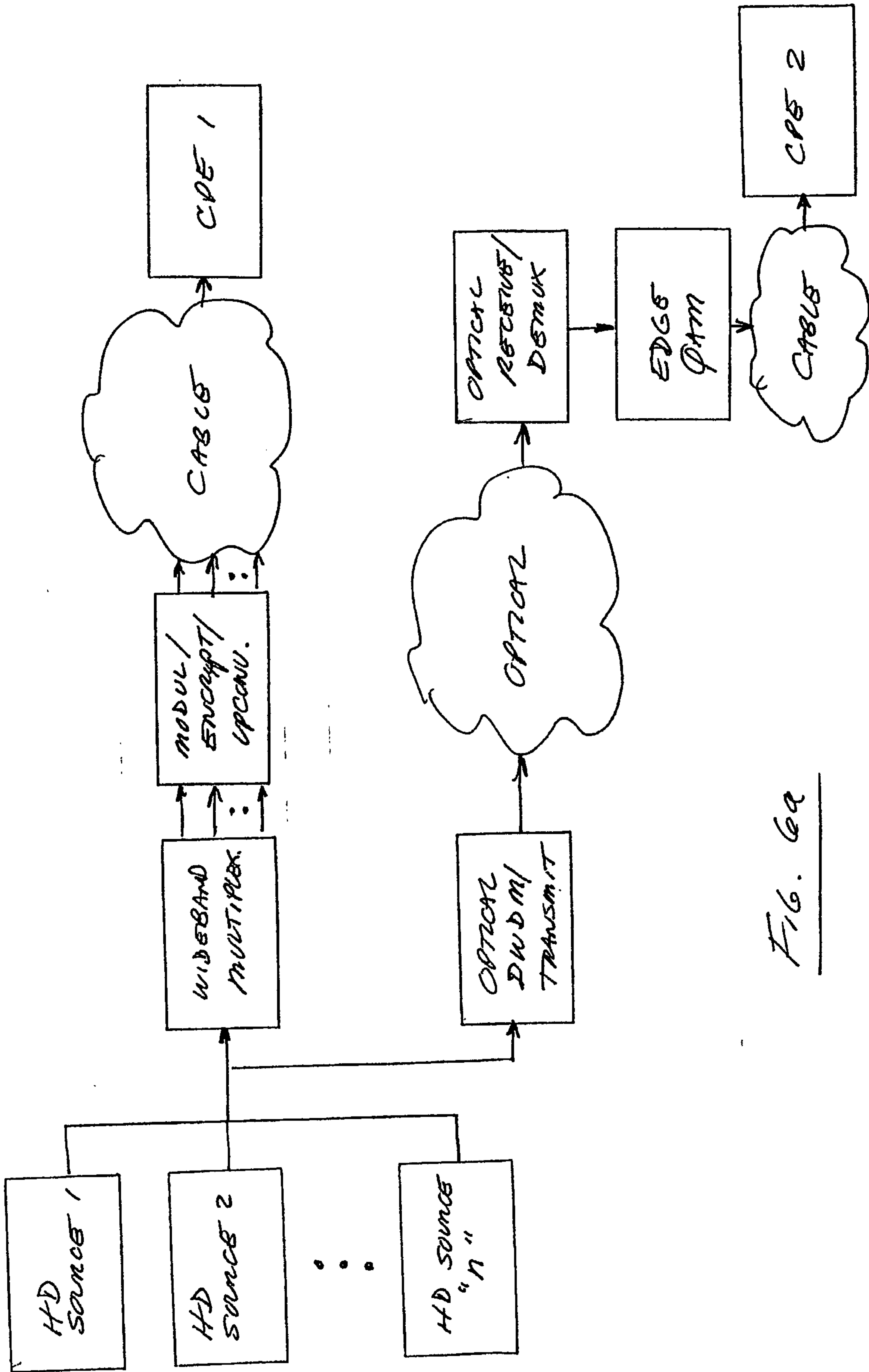

FIG. 6a

