



US 20140144030A1

(19) **United States**

(12) **Patent Application Publication**  
**Heaton et al.**

(10) **Pub. No.: US 2014/0144030 A1**

(43) **Pub. Date: May 29, 2014**

(54) **EKG TARGETING SYSTEM**

(71) Applicants: **Mark A. Heaton**, Elberta, AL (US);  
**Thomas Lee Melvin**, Elberta, AL (US)

(72) Inventors: **Mark A. Heaton**, Elberta, AL (US);  
**Thomas Lee Melvin**, Elberta, AL (US)

(21) Appl. No.: **13/687,553**

(22) Filed: **Nov. 28, 2012**

**Publication Classification**

(51) **Int. Cl.**  
**F41G 1/467** (2006.01)

(52) **U.S. Cl.**

CPC ..... **F41G 1/467** (2013.01)

USPC ..... **33/228; 33/265**

(57)

**ABSTRACT**

The present invention is a mechanical device used in the hunting and gaming industries. The device is a system called the EKG targeting system, which is comprised of a scope, which, in one embodiment is comprised of a laser rangefinder, an L-shaped sliding mount, a sliding face-mount bracket, a trigger release mounting bracket, bolts and nuts to secure pieces of the system together, a pin sight, a mounting for the pin sight and a trigger release. In another embodiment, the system is comprised of almost any scope used in archery targeting, an L-shaped sliding mount, a sliding face-mount bracket, a trigger release mounting bracket, bolts and nuts to secure pieces of the system together and a trigger release.

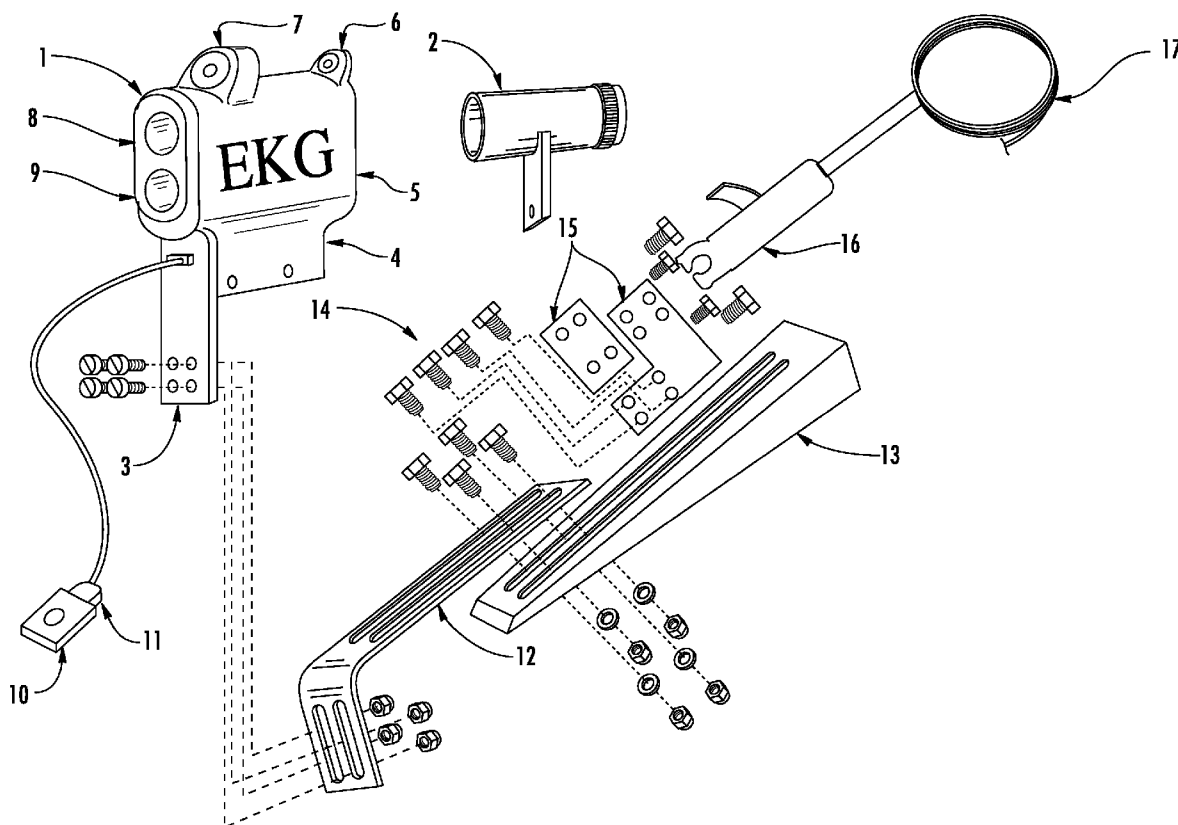

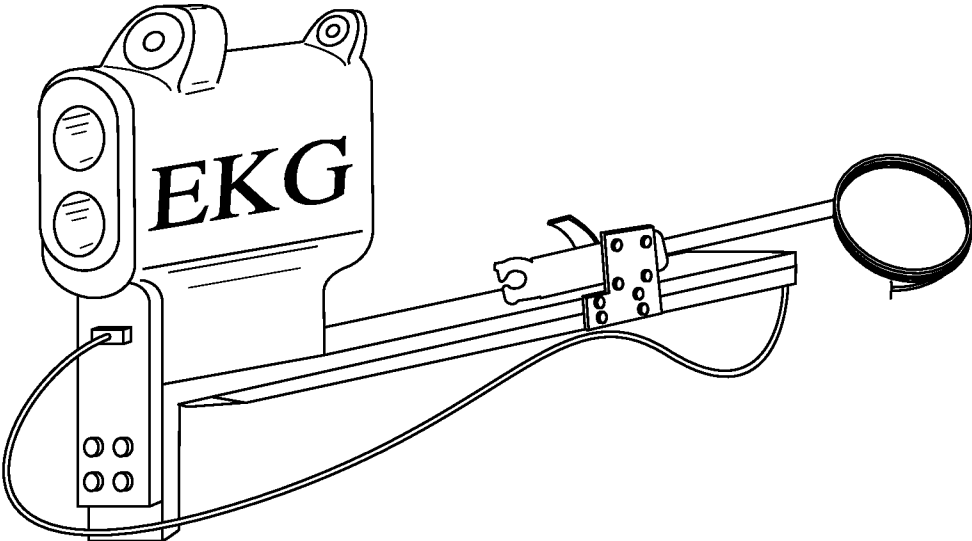

**FIG. 1**

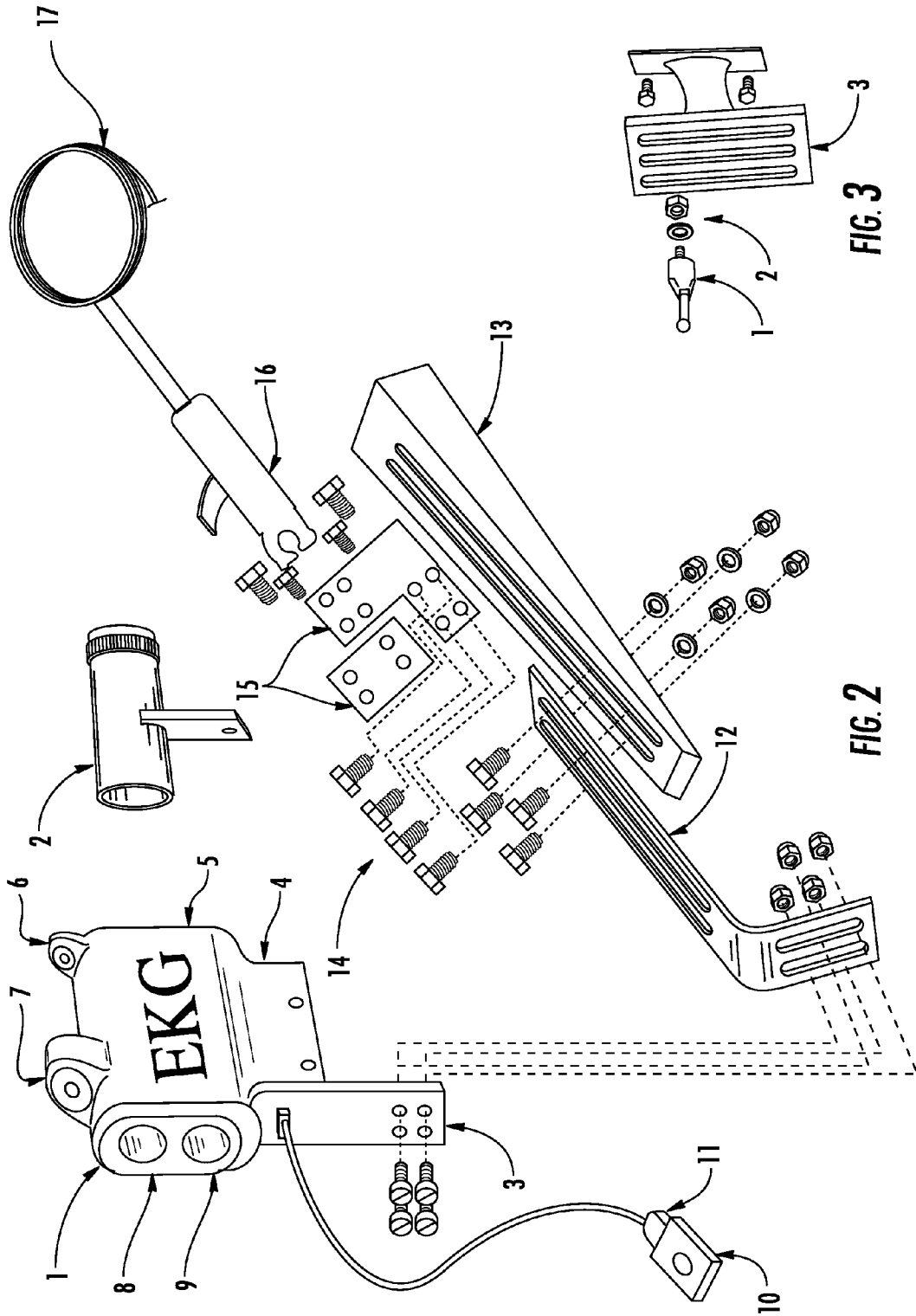

**EKG TARGETING SYSTEM**

**[0001]** We are claiming the filing date of Nov. 28, 2011 of Provisional Application #61/629,812.

**CROSS-REFERENCE TO RELATED APPLICATIONS**

Not Applicable

**STATEMENT REGARDING FEDERALLY SPONSORED RESEARCH OR DEVELOPMENT**

Not Applicable

**REFERENCE TO SEQUENCE LISTING, A TABLE, OR A COMPUTER PROGRAM LISTING COMPACT DISK APPENDIX**

**[0002]** Not Applicable

The following definitions have been provided for a precise understanding of the terminology used in the present application.

**DEFINITIONS**

**[0003]** Basic Unit: a unit which is comprised of an L-shaped sliding mount, a sliding face-mount bracket and a trigger release mounting bracket that a scope, a pin sight and a trigger release may be attached to and that, taken as an entire unit, forms the basis for the EKG system.

Non-magnified Scope: any scope used in targeting, as long as it is non-magnified

Red Dot Technology: Red Dot Technology is a floating red dot that appears in a targeting scope that is currently used in the field of archery. It is used to properly align a scope. If the red dot does not appear in the center of the scope, the user knows that the scope must be readjusted to be in proper alignment.

SCOPE: Any scope used in the field of archery including range finding scopes and non-magnified scopes.

**BACKGROUND OF THE INVENTION**

**[0004]** The present invention is in the technical field of archery. More particularly, the present invention is in the technical field of targeting in archery.

**[0005]** The present invention, which is called the EKG targeting system, is a targeting system used in archery. The EKG Targeting System provides for a long felt need in the archery industry to provide accuracy and consistency in shooting. The system is based on a basic unit comprised of an L-shaped sliding mount, a sliding face-mount bracket and a trigger-release mounting bracket that a scope, a pin-sight and a trigger release may be attached to. Further, the complete system is comprised of a non-magnified scope, an L-shaped sliding mount, a sliding face-mount bracket, a trigger release, a trigger release mounting bracket, a pin sight and the pin sight mounting, bolts and nuts to secure pieces of the system together and a trigger release.

**[0006]** The purpose of the invention is to enhance an archer's accuracy and consistency. The EKG Targeting System implements an extra level of shooting accuracy by allowing the attachment of most scopes including ones with Red Dot Technology. Traditional targeting utilizes a string peep sight and riser mounted pin-sights and only has 3 points of target reference: the peep-sight, the pin-sight and the target.

The EKG targeting system has 4 points of reference: the back aperture, front aperture with optional Red Dot Technology, pin-sight and target. This extra level of alignment allows for the most accurate targeting ever introduced to archery.

**[0007]** The EKG targeting system also offers the shooter range-finding capabilities. The EKG system may be used with a laser rangefinder, which removes the need to have a separate device for determining distance to targets. It also reduces unnecessary movements by combining the range finding phase with the targeting phase. The EKG system is designed with value in mind, as it is universally adaptable to most open pin-sights, most trigger-releases and most non-magnified scopes on the market today.

**SUMMARY OF THE INVENTION**

**[0008]** The present invention is a mechanical system used in targeting in archery. The system is called the EKG targeting system. The system is based on the use of a basic unit comprised of an L-shaped sliding mount, a sliding face-mount bracket and a trigger release mounting bracket that a scope to which a pin-sight and a trigger release may be attached. The system with all of the added components is comprised of a non-magnified scope, an L-shaped sliding mount, a sliding face-mount bracket, a trigger release, a trigger release mounting bracket, bolts and nuts to secure pieces of the system together and a trigger release. In another embodiment the scope used may be a laser rangefinder. Almost any typical rangefinder may be used as the scope. In another embodiment, a rangefinder sight with red dot technology may be used as a scope. Nuts and bolts are used to secure the various components to the basic unit.

**[0009]** In one embodiment, the EKG targeting system is a targeting system that is comprised of a non-magnified scope that is attached to a sliding mount, a sliding mount made from air craft aluminum, with a curved portion, slits running down said mount, which end at the curve and then begin again at the curve and is non-rail, a face-mount with jawbone bevel with rail system down its length, four bolts on the L-shaped bracket with four nuts to secure the bolts, four bolts on the trigger release bracket in the grooves on the face mount that will pass through all 3 pieces of the L-bracket face-mount and trigger mount and four nuts to secure the bolts, four bolts and nuts to secure the rail system, four bolts and nuts to secure the non-magnified scope to the sliding mount, a trigger release mount comprised of two parts: a rectangle bracket and an L-shaped bracket, both with holes in them, a trigger release that is mounted to the trigger release mount, a pin sight, a pin sight mount, one lock washer and nut on the pin sight portion and a wrist strap.

**[0010]** In another embodiment, the EKG targeting system is a targeting system that, when using a laser rangefinder, is comprised of a laser rangefinder that is connected to an L-shaped bracket, a 9-volt battery, an LCD Screen Y/M display, a rear peep aperture, a front aperture with red dot technology, a laser sending unit, a laser receiving unit, a mounting tab, an on/off set button, a sliding mount made from air craft aluminum, with a curved portion, slits running down said mount, which end at the curve and then begin again at the curve and is non-rail. The system is further comprised of a face-mount with jawbone bevel with rail system down its length, four bolts on the L-shaped bracket with four nuts to secure the bolts, four bolts on the trigger release bracket in the grooves on the face mount, that will pass through all 3 pieces of the L-bracket, face-mount and trigger mount and four nuts

to secure the bolts, four bolts to secure the non-magnified scope unit to the sliding mount, four bolts to secure the rail system, one lock washer and nut on the pin sight portion, a trigger release system comprised of two parts: a rectangle bracket and an L-shaped bracket, both with holes in them, a trigger release that is mounted to the L-shaped bracket and a wrist strap.

**[0011]** In another embodiment, this targeting system is comprised of the above mentioned components further comprised of the sliding mount which may be made from air craft aluminum, measuring 9 inches in length by  $\frac{3}{4}$  inch in width, the curved portion measuring 2 and  $\frac{3}{4}$  inches length by  $\frac{3}{4}$  inch width, having  $\frac{3}{16}$  of an inch slits running down the 9 inch portion which end at the curve and then begin again at the curve and is non-rail; the face-mount with jawbone bevel measuring 6 inches by  $\frac{13}{16}$  inches and with a  $\frac{3}{16}$  inch rail system down its length; the four bolts on the L-shaped bracket are  $\frac{1}{8}$  by  $\frac{3}{8}$  bolts and have four nuts to secure the bolts; the four bolts on the trigger release bracket are  $\frac{1}{8}$  by  $\frac{3}{8}$  bolts and are in the grooves on the face mount, and will pass through all 3 pieces of the L-bracket, face-mount and trigger mount and four nuts to secure the bolts; there are four bolts and nuts to secure the rail system are  $\frac{3}{16}$  by  $\frac{3}{4}$  bolts; there are four  $\frac{1}{8}$  by  $\frac{3}{8}$  bolts and nuts used to secure the non-magnified scope to the sliding mount; the rectangle bracket and the L-shaped bracket have  $\frac{1}{8}$  of an inch holes in them; the mount measuring  $\frac{3}{4}$  on one end and  $\frac{1}{2}$  inch on the other, with each side being 1 and  $\frac{1}{2}$  inches long and the trigger release having a  $\frac{3}{8}$  to  $\frac{1}{2}$  inch space for mounting to the L-shaped bracket. The targeting system can further be comprised of an ordinary scope, or a laser rangefinder with or without Red Dot Technology.

**[0012]** To use the invention with a laser rangefinder, one must connect the wrist strap to his wrist. Next one must connect the trigger release to the bow's string. This operation works just as it does with a standard trigger. Next the bow's string must be drawn back to full draw. At this point, the back aperture aligns with the dominant eye. Now one must look through the back aperture to the front aperture and see the red dot appear in the front aperture. Then, one must align the red dot with the operate pin sight out on the riser and align the pin sight on the target. When the target is acquired, one can squeeze the trigger on the trigger release.

**[0013]** To use the invention with a non-laser range finding scope, one must connect the wrist strap to his wrist. Next one must connect the trigger release to the bow's string. This operation works just as it does with a standard trigger. Next the bow's string must be drawn back to full draw. At this point, the back aperture aligns with the dominant eye. One must align the pin sight on the target. When the target is acquired, one can squeeze the trigger on the trigger release.

**[0014]** The pieces in this system may be produced from molded carbon plastic or molded aircraft aluminum, a combination of these materials or any suitable lightweight material.

**[0015]** This system, when assembled, will vary in dimension depending on the user's configurations. The device can range in height from 3.25 inches to 6 inches. The system's length can range from 4.5 inches to 10 inches. The unit housing is 3 and  $\frac{1}{8}$  inches long and 3 and  $\frac{1}{4}$  inch high with a mounting tab of 2 and  $\frac{3}{4}$  inch long by  $\frac{1}{16}$  inches wide and  $\frac{3}{16}$  inches thick. The unit housing is 1 and  $\frac{1}{8}$  inches wide. The sliding mount is 9 inches long and  $\frac{3}{4}$  inches wide. It has a 90-degree turn that extends it another 2 and  $\frac{3}{4}$  inches. The 2 and  $\frac{3}{4}$  inch turn has a rail feature that will accommodate the

$\frac{1}{16}$  by  $\frac{3}{16}$  inch unit housing mounting tab. The face mount with Jawbone bevel is 6 inches long by  $\frac{13}{16}$  inches wide. It also has the  $\frac{3}{16}$ -inch rail system down its entire length. The jawbone bevel is  $1\frac{1}{2}$  inches high and angles upward toward the length of the face mount. The trigger release mount is L-shaped and is  $\frac{3}{4}$  inches on one end and  $\frac{1}{2}$  inch on the other and is  $\frac{3}{16}$  inches thick. Each side is 1 and  $\frac{1}{2}$  inches long.

#### BRIEF DESCRIPTION OF THE DRAWINGS

**[0016]** FIG. 1 is a side view of the present invention assembled;

**[0017]** FIG. 2 is a side view of the present invention disassembled; and

**[0018]** FIG. 3 is a side view of a disassembled standard open pin system.

#### DETAILED DESCRIPTION OF THE INVENTION

**[0019]** This system is comprised of four main components: the non-magnified scope, the basic unit, which is comprised of an L-shaped sliding mount, a sliding face-mount bracket and a trigger release mounting bracket that a scope and a trigger release may be attached to, the pin sight and a trigger release. To assemble, pick up the L-shaped bracket with the L-shape pointing down. Next pickup the non-magnified scope and slide it into the grooves on the L-shaped bracket. Then insert four  $\frac{1}{8}$  by  $\frac{3}{8}$  bolts into the holes on the bracket and secure with the locknuts being sure to leave them loose. Pickup the sliding face-mount and slide the non-magnified scope/L-bracket assembly into the grooves on the face-mount. Insert the trigger release bracket in the grooves on the face mount. Insert four  $\frac{1}{8}$  by  $\frac{1}{2}$  bolts. These bolts will pass through all 3 pieces of the L-bracket, face-mount and trigger mount. Install the locknuts. Align the trigger release alongside the face-mount under the release-mounting bracket. Place the second piece of trigger mounting bracket under trigger release. Ensure the trigger release is lined up so that the bracket does not interfere with the trigger function. Insert four  $\frac{3}{16}$  by  $\frac{3}{4}$  bolts in mounting holes. Install locknuts and, if using a laser rangefinder, remove desired bolt to mount the laser rangefinder function button and then install the button.

#### DETAILED DESCRIPTION OF DRAWINGS

**[0020]** FIG. 1 is the present invention fully assembled. FIG. 2 is the entire system and it contains both a laser rangefinder, Part 1, and a non-magnified scope, Part 2. Either the laser rangefinder or the scope may be attached to the sliding mount, but not both at the same time. Part 1 is a laser rangefinder with Red Dot Technology. Part 2 is the non-magnified scope. Part 3 is the portion of the laser rangefinder that is connected to the L-shaped bracket. The corresponding portion on the non-magnified scope would be attached at this junction is used in lieu of the laser rangefinder. Part 4 houses a 9-volt battery. Part 5 is where the LCD Screen Y/M display is. Part 6 is the rear peep aperture. Part 7 is the front aperture with Red Dot Technology. Part 8 is the laser-sending unit. Part 9 is the laser-receiving unit. Part 10 is the mounting tab. Part 11 is the on/off set button. Part 12 is the sliding mount. It measures 9 inches in length  $\frac{3}{4}$  inch width. The curved portion measures 2 and  $\frac{3}{4}$  inches length by  $\frac{3}{4}$  inch width. This mount has  $\frac{3}{16}$  of an inch slits running down the 9 inch portion which ends at the curve and then begins again at the curve. The 9-inch portion is non-rail. Part 13 is the face-mount with jawbone bevel. It measures 6" by  $\frac{13}{16}$  with  $\frac{3}{16}$  slits running down it. It is a  $\frac{3}{16}$

inch slid rail to allow for double stacking. Part 14 are the nuts and bolts that are used in the L-shaped bracket and in the sliding mount. Part 15 is the trigger release mount, which is comprised of two parts; one being a rectangle bracket and one being L-shaped bracket. Both parts have 1/8 of an inch holes in them. The trigger release mount is L-shaped and is 3/4 on one end and 1/2 inch on the other, with each side being 1 and 1/2 inches long. Part 16 is the trigger release. This release must have a 3/8 to 1/2 inch space for mounting to the L-shaped bracket. Part 17 is the wrist strap.

[0021] FIG. 3 is a standard open pin system. Closed sight models may also work. Part 1 is the pin sight. Part 2 is the lock washer and nut. Part 3 is the body of the pin system.

[0022] While the foregoing written description of the invention enables one of ordinary skill to make and use what is considered presently to be the best mode thereof, those of ordinary skill will understand and appreciate the existence of variations, combinations, and equivalents of the specific embodiment, method, and examples herein. The invention should therefore not be limited by the above described embodiment, method, and examples, but by all embodiments and methods within the scope and spirit of the invention as claimed.

We are claiming the following:

1. A targeting system that is comprised of:

- a non-magnified scope that is attached to a sliding mount;
- a sliding mount made from air craft aluminum, with a curved portion, slits running down said mount, which end at the curve and then begin again at the curve and is non-rail;
- a face-mount with jawbone bevel with rail system down its length;
- four bolts on the L-shaped bracket with four nuts to secure the bolts;
- four bolts on the trigger release bracket in the grooves on the face mount that will pass through all 3 pieces of the L-bracket face-mount and trigger mount and four nuts to secure the bolts;
- four bolts and nuts to secure the rail system;
- four bolts and nuts to secure the non-magnified scope to the sliding mount;
- a trigger release mount comprised of two parts: a rectangle bracket and an L-shaped bracket, both with holes in them;
- a trigger release that is mounted to the trigger release mount;
- a pin sight;
- a pin sight mount;
- one lock washer and nut on the pin sight portion; and
- a wrist strap.

2. The targeting system of claim 1, further comprised of a laser rangefinder as the non-magnified scope.

3. The targeting system of claim 1, further comprised of a rangefinder sight that has Red Dot Technology as the non-magnified scope.

4. The targeting system of claim 1, further:

- said sliding mount made from air craft aluminum measuring 9 inches in length by 3/4 inch in width, the curved portion measuring 2 and 3/4 inches length by 3/4 inch width, having 3/16 of an inch slits running down the 9 inch portion which end at the curve and then begin again at the curve and is non-rail;
- said face-mount with jawbone bevel measuring 6 inches by 13/16 inches and with a 3/16-inch rail system down its length;
- said four bolts measuring 1/8 by 3/8 on the L-shaped bracket with four nuts to secure the bolts;
- said four bolts measuring 1/8 by 3/8 and nuts to secure the scope to the sliding mount;
- said four bolts measuring 1/8 by 1/2 and nuts fastened on the trigger release bracket in the grooves on the face mount, that will pass through all 3 pieces of the L-bracket, face-mount and trigger mount and four nuts to secure the bolts;
- said four bolts measuring 3/16 by 3/4 and nuts to secure the rail system;
- said rectangle bracket and an L-shaped bracket comprised of 1/8 of an inch holes in them; and the mount measuring 3/4 on one end and 1/2 inch on the other, with each side being 1 and 1/2 inches long;
- said trigger release with a 3/8 to 1/2 inch space for mounting to the EKG system.

5. A unit comprised of an L-shaped sliding mount, a sliding face-mount bracket and a trigger-release mounting bracket that a scope, a pin sight and a trigger release may be attached to.

- 6. The method of use of the system of claim 1 comprised of:
  - connecting the wrist strap to one's wrist;
  - connecting the trigger release to the bow's string;
  - drawing back the string to full draw;
  - aligning the back aperture with the dominant eye;
  - acquiring the target;
  - aligning the pin sight on the target; and
  - squeezing the trigger on the trigger release.

7. The method of claim 6, further comprised of using a scope with Red Dot Technology and after aligning the back aperture with the dominant eye, looking through the back aperture to the front aperture to visualize the red dot appear in the front aperture; aligning the red dot with the operate pin sight out on the riser; aligning the pin sight on the target and once the target is acquired, squeezing the trigger on the trigger release.

\* \* \* \* \*