

(No Model.)

G. H. FOSTER & P. H. FARRELL.
INKSTAND.

No. 481,649.

Patented Aug. 30, 1892.

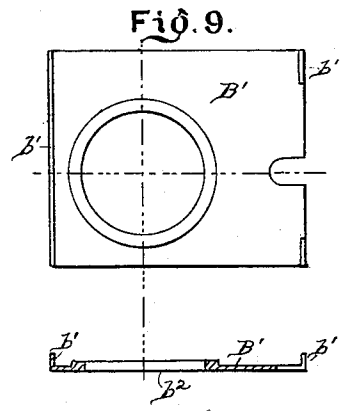
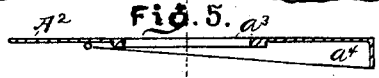
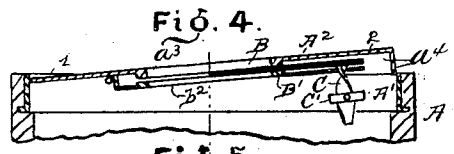
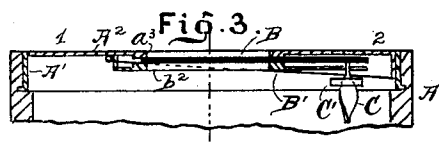
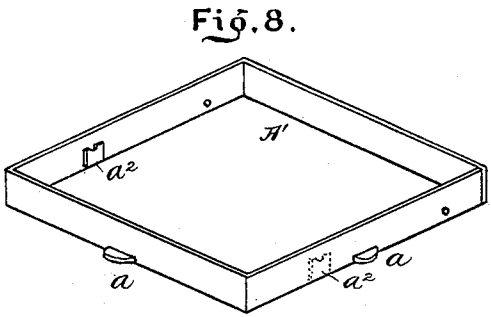
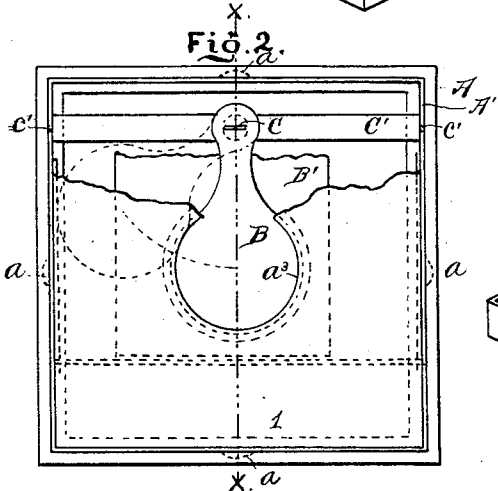
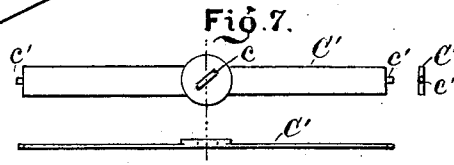
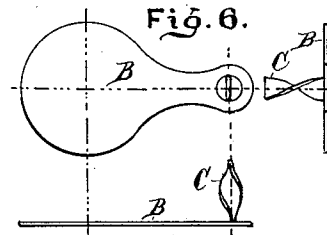
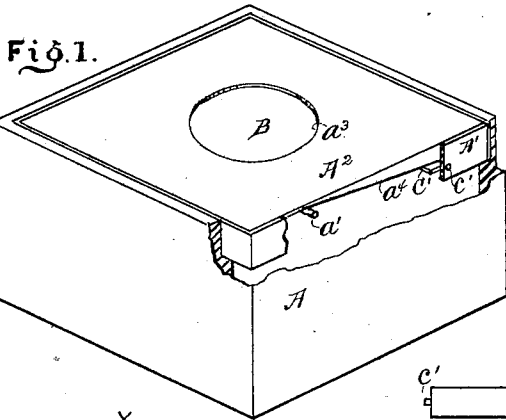

WITNESSES:

C. R. Ferguson
Wm. M. Shiff

INVENTORS.

George H. Foster
Philip H. Farrell
BY
Edwin V. Brown
THEIR ATTORNEY

UNITED STATES PATENT OFFICE.

GEORGE H. FOSTER AND PHILIP H. FARRELL, OF BROOKLYN, NEW YORK.

INKSTAND.

SPECIFICATION forming part of Letters Patent No. 481,649, dated August 30, 1892.

Application filed January 5, 1892. Serial No. 417,061. (No model.)

To all whom it may concern:

Be it known that we, GEORGE H. FOSTER and PHILIP H. FARRELL, both of Brooklyn, county of Kings, and State of New York, have invented a certain new and useful Improvement in Inkstands, of which the following is a specification.

This invention relates to inkstands; and it consists in the construction and novel arrangement of parts, as hereinafter set forth.

We will describe an inkstand embodying our improvement and then point out the novel features in claims.

In the accompanying drawings, Figure 1 is a perspective view of an inkstand embodying our improvement with a portion broken away. Fig. 2 is a plan view with a portion of the top broken away. Fig. 3 is a section on the line xx of Fig. 2, showing the cover in a normal position. Fig. 4 is a section on the line xx of Fig. 2, showing the cover in another position. Fig. 5 is a section of tilting top on the line xx of Fig. 2. Fig. 6 is a plan and edge view of a movable cover. Fig. 7 is a plan and edge view of a rock-bar employed. Fig. 8 is a perspective view of a frame which may be employed in the construction. Fig. 9 is a plan and cross-section of a plate adapted to be secured to the under side of the top plate.

Referring by letter and numerals to the drawings, A designates an ink-fount, which may be made of any suitable material, such as metal, glass, hard rubber, or similar material. When the fount A is made of glass, hard rubber, or the like, we prefer to attach to its upper inner edge a metal frame A', in which bearings may be formed for certain movable parts hereinafter mentioned. This frame A' may be secured in place by means of lugs a , with which it is provided and around which the material of the fount may be cast or vulcanized.

A² shows a metal top plate fitted within the frame A' and designed to have a tilting motion imparted to it. With that end in view we provide it with trunnions a' , which have bearings a^2 in the frame A'. These trunnions are shown as arranged between the longitudinal center of the plate A² and one of its edges, so that said plate will require but a slight tilt to operate a closure B for its central opening a^3 . The plate A² has a downwardly-extend-

ing flange a^4 at three of its sides, as shown, to prevent the entrance of dirt or dust to the interior of the fount when the said plate is tilted. The closure B is laterally movable to open and close the opening a^3 . It is moved away from said opening by the tilting of the plate A² and is operated to close the opening by a return movement of said plate. The closure operates in a pocket b , having one of its walls formed by the inner side of the plate A² and the other of its walls formed by a plate B', having opposite upwardly-turned edges b' , secured to the plate A². This plate B' has an opening b^2 through it, registering with the opening a^3 , so that a pen may be inserted to the ink.

The closure B has secured to it a screw-shaped cam C, which passes loosely through a slot c in a rock-bar C'. This rock-bar C' is provided at its ends with journals c' , having bearings in the frame A'. The object in providing a rocking motion for the bar C' is to accommodate the bearing or slot c to the vertical movement of the cam C.

The operation of the device is as follows: A downward pressure on the plate A², which is in effect a finger-piece, at the side 1 will tilt the opposite side 2 upward, which will carry the closure B with it. This tilting will cause the cam C to move upward through the slot c , and owing to its screw form the cam will cause the closure to swing laterally into the position shown in dotted line in Fig. 2, so that a pen may be inserted to the ink. Upon releasing the pressure on the plate A² it will, owing to its greater weight at the side 2 of its trunnions, return to its normal position and automatically cause the closure B to close the opening a^3 .

Having described our invention, what we claim is—

1. The combination, with an ink-fount, of a top therefor provided with an opening, an automatically-operating closing-cover for said opening, and a movable finger rest or piece which may be operated in the act of passing a pen to the opening to effect the uncovering of the opening, substantially as specified.

2. In an inkstand, the combination, with a fount, of a tilting top having an opening through it and a closure operated by the movements of said top, substantially as specified.

3. In an inkstand, the combination, with a
fount, of a tilting top plate provided with an
opening and having trunnion-bearings in said
fount and a laterally-movable closure oper-
5 ated by the movements of said top plate, sub-
stantially as specified.

4. In an inkstand, the combination, with a
fount, of the tilting top plate having an open-
ing, a closure for said opening, a cam on said
10 closure, and a rock-bar having a bearing for
said cam, substantially as specified.

5. In an inkstand, the combination, with
the fount or body, of the metal frame secured

in said fount or body, a tilting plate having
trunnion-bearings in said frame, and a closure 15
for an opening in the plate, operated by move-
ments of said plate, substantially as specified.

In testimony whereof we have signed our
names to this specification in the presence of
two subscribing witnesses.

GEORGE H. FOSTER.
PHILIP H. FARRELL.

Witnesses:

S. O. EDMONDS,
C. R. FERGUSON.