



(51) International Patent Classification:

E21B 23/01 (2006.01) E21B 17/02 (2006.01)

(21) International Application Number:

PCT/US2018/034426

(22) International Filing Date:

24 May 2018 (24.05.2018)

(25) Filing Language:

English

(26) Publication Language:

English

(30) Priority Data:

15/604,124 24 May 2017 (24.05.2017) US

(71) Applicant: **BAKER HUGHES, A GE COMPANY, LLC** [US/US]; 17021 Aldine Westfield, Houston, TX 77073 (US).

(72) Inventors: **EGGERS, Heiko**; Hauptstrasse 74a, 29683 Dorfmark (DE). **MELLES, Henning**; Wittinger Strasse 132A, 29223 Celle (DE).

(74) Agent: **CARSON, Matt, W.**; Intellectual Property Counsel, Baker Hughes, A GE Company, LLC, 17021 Aldine Westfield, Houston, TX 77073 (US).

(81) Designated States (unless otherwise indicated, for every kind of national protection available): AE, AG, AL, AM, AO, AT, AU, AZ, BA, BB, BG, BH, BN, BR, BW, BY, BZ, CA, CH, CL, CN, CO, CR, CU, CZ, DE, DJ, DK, DM, DO,

DZ, EC, EE, EG, ES, FI, GB, GD, GE, GH, GM, GT, HN, HR, HU, ID, IL, IN, IR, IS, JO, JP, KE, KG, KH, KN, KP, KR, KW, KZ, LA, LC, LK, LR, LS, LU, LY, MA, MD, ME, MG, MK, MN, MW, MX, MY, MZ, NA, NG, NI, NO, NZ, OM, PA, PE, PG, PH, PL, PT, QA, RO, RS, RU, RW, SA, SC, SD, SE, SG, SK, SL, SM, ST, SV, SY, TH, TJ, TM, TN, TR, TT, TZ, UA, UG, US, UZ, VC, VN, ZA, ZM, ZW.

(84) Designated States (unless otherwise indicated, for every kind of regional protection available): ARIPO (BW, GH, GM, KE, LR, LS, MW, MZ, NA, RW, SD, SL, ST, SZ, TZ, UG, ZM, ZW), Eurasian (AM, AZ, BY, KG, KZ, RU, TJ, TM), European (AL, AT, BE, BG, CH, CY, CZ, DE, DK, EE, ES, FI, FR, GB, GR, HR, HU, IE, IS, IT, LT, LU, LV, MC, MK, MT, NL, NO, PL, PT, RO, RS, SE, SI, SK, SM, TR), OAPI (BF, BJ, CF, CG, CI, CM, GA, GN, GQ, GW, KM, ML, MR, NE, SN, TD, TG).

Published:

- with international search report (Art. 21(3))
- before the expiration of the time limit for amending the claims and to be republished in the event of receipt of amendments (Rule 48.2(h))

(54) Title: SOPHISTICATED CONTOUR FOR DOWNHOLE TOOLS

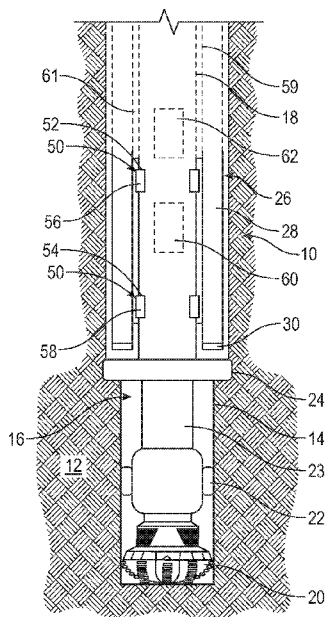

FIG. 1

(57) Abstract: A well tool includes a first component, a second component having a passage for receiving the first component, and an anchor assembly. The anchor assembly includes at least one anchor positioned on the first component that is received by at least one profile formed on an inner surface defining the passage of the second component. Either or both of the at least one profile and the at least one anchor include a ramp section that has a ramp contour defined by a ramp tangent. The ramp tangent forms an acute angle with a longitudinal axis of the borehole. A related method includes the steps of forming at least one profile in the second component, the at least one profile including a ramped section; disposing at least one anchor in the first component; and lowering the first component relative to the second component until the first anchor and the first profile align the first component and the second component in a predetermined relative alignment.

- 1 -

**TITLE:                    SOPHISTICATED CONTOUR FOR DOWNHOLE  
                                 TOOLS**

### **BACKGROUND OF THE DISCLOSURE**

1.        Field of the Disclosure

[0001]    This disclosure relates generally to oilfield downhole tools and more particularly to contours and related methods for selectively connecting well tools.

2.        Description of the Related Art

[0002]    To obtain hydrocarbons such as oil and gas, boreholes are drilled by rotating a drill bit attached to the bottom of a BHA (also referred to herein as a "Bottom Hole Assembly" or ("BHA")). The BHA is attached to the bottom of a tubing, which is usually either a jointed rigid pipe or a relatively flexible spoolable tubing commonly referred to in the art as "coiled tubing." The string comprising the tubing and the BHA is usually referred to as the "drill string." In some situations, tubulars like tools or sections of a drill string or BHA may need to be connected or disconnected in the borehole and / or at the surface. The connection may be a radial connection between an inner and an outer tubular as opposed to an axial connection. Also, the connection or disconnection may be before the BHA is retrieved to the surface (*i.e.*, run uphole). The present disclosure addresses the need to efficiently and reliably connect and / or disconnect drilling tools, as well as other well tools, in a downhole location and / or at a surface location.

### **SUMMARY OF THE DISCLOSURE**

[0003]    In aspects, the present disclosure provides a well tool that includes a first component, a second component having a passage for receiving the first component, and an anchor assembly. The anchor assembly includes at least

- 2 -

one anchor positioned on the first component, and at least one profile formed on an inner surface defining the passage of the second component and configured to receive the at least one anchor. Either or both of the at least one profile and the at least one anchor may include a ramp section. The ramp section may have a ramp contour defined by a ramp tangent. The ramp tangent may form an acute angle with a longitudinal axis of the borehole, the acute angle being larger than 1 degree and smaller than 90 degrees.

**[0004]** In aspects, the present disclosure also provides a related method that includes the steps of forming at least one profile in the second component, the at least one profile including a ramped section; disposing at least one anchor in the first component; and lowering the first component relative to the second component until the first anchor and the first profile align the first component and the second component in a predetermined relative alignment.

**[0005]** Illustrative examples of some features of the disclosure thus have been summarized rather broadly in order that the detailed description thereof that follows may be better understood, and in order that the contributions to the art may be appreciated. There are, of course, additional features of the disclosure that will be described hereinafter and which will form the subject of the claims appended hereto.

### BRIEF DESCRIPTION OF THE DRAWINGS

[0006] For detailed understanding of the present disclosure, references should be made to the following detailed description of the preferred embodiment, taken in conjunction with the accompanying drawings, in which like elements have been given like numerals and wherein:

**FIG. 1** shows a schematic diagram of a well construction system with a bottomhole assembly utilizing an anchor assembly of the present disclosure;

**FIG. 2** shows a sectional view of profiles for an anchor in accordance with the present disclosure;

**FIG. 3A** and **3B** sectionally and isometrically illustrate an embodiment of contours in accordance with the present disclosure;

**FIG. 4A** shows an unfolded view of a section of a well tool where contours and anchors mate and align;

**FIG. 4B** shows an unfolded view of a section of a well tool where contours and anchors are configured to mate only in a coded position;

**FIG. 5** is a line diagram of an exemplary drill string that includes an inner string and an outer string, wherein the inner string is connected to a first location of the outer string to drill a hole of a first size;

**FIG. 6A** is a schematic illustration of a liner and running tool in accordance with an embodiment of the present disclosure;

**FIG. 6B** is a schematic illustration of the running tool of **FIG. 6A** as viewed along the line B-B;

**FIG. 6C** is a schematic illustration of the running tool of **FIG. 6A** as viewed along the line C-C;

**FIG. 7A** is a schematic illustration of a portion of a running tool and a

- 4 -

liner in accordance with an embodiment of the present disclosure having a position detecting system; and

**FIG. 7B** is a detailed illustration of the marker of **FIG. 7A**.

### DETAILED DESCRIPTION OF THE DISCLOSURE

[0007] The present invention relates to an apparatus and methods for selectively connecting and / or disconnecting well components while at the surface or downhole. In some arrangements, the components may be concentrically arranged with an inner component disposed inside a bore or passage of an outer component. In other arrangements, the alignment may be eccentric or only partially overlapping. As used herein, a "component" may be a downhole tool, a drill string, a bottomhole assembly (BHA), casing, liner, packer, or any other tool, instrument, equipment, or structure used while drilling, completing, or otherwise constructing, servicing, or operating a well.

[0008] Embodiments of the present disclosure may include anchors that are self-aligning in the borehole. That is, as personnel bring the two components into mating engagement, one or both of the components rotate or move relative to one another to allow the anchors to properly orient and engage. The orientation, or alignment, may have a circumferential, radial, and / or axial component. This process may be done automatically or controlled by personnel. The features that enable the self-alignment are referred to as "contours" or "ramps," and are discussed in further detail below.

[0009] The teachings of the present disclosure may be advantageously applied to a variety of well tools and systems. One non-limiting application for anchors according to the present disclosure is liner drilling. Liner drilling may be useful for drilling a borehole in underground formations with at least one formation that has a significantly different formation pressure than an adjacent formation or where time dependent unstable formations do not allow sufficient time to case off the hole in a subsequent run.

[0010] In **Fig. 1**, there is shown an embodiment of a liner drilling system **10** that may use anchoring devices according to the present disclosure. The teachings of the present disclosure may be utilized in land, offshore or subsea applications. In **FIG.1**, a laminated earth formation **12** is intersected by a

- 6 -

borehole **14**. A BHA **16** is conveyed via a drill string **18** into the borehole **14**. The drill string **18** may be jointed drill pipe or coiled tubing, which may include embedded conductors for power and / or data for providing signal and / or power communication between the surface and downhole equipment. The BHA **16** may include a drill bit **20** for forming the borehole **14**. The BHA **16** may also include a steering unit **22** and a drilling motor **23**. Other tools and devices that may be included in the BHA **10** include steering units, MWD/LWD tools that evaluate a borehole and / or surrounding formation, stabilizers, downhole blowout preventers, circulation subs, mud pulse instruments, mud turbines, etc. When configured as a liner drilling assembly to perform liner drilling, the BHA **16** utilizes a reamer **24** and a liner assembly **26**. The liner assembly **26** may include a wellbore tubular **28** and a liner bit **30**.

[0011] An anchor assembly **50** may be used to selectively connect the liner assembly **26** with the drill string **18**. In one embodiment, the anchor assembly **50** may include a torque anchor **52** and a weight anchor **54** that selectively engage with a torque profile **56** and a weight profile **58**, respectively. By selectively, it is meant that the anchor assembly **50** may be remotely activated and / or deactivated multiple times using one or more control signals and while the anchor assembly **50** is in the borehole **14** or at the surface. While the torque anchor **52** is shown uphole of the weight anchor **54**, their relative positions may also be reversed.

[0012] The anchors **52**, **54** are positioned on the drill string **18** and may be members such as ribs, teeth, rods, or pads that can be shifted between a retracted and a radially extended position using an actuator **60**. In some embodiments, the anchors **52**, **54** may be fixed in the radially extended position. The actuator **60** may be electrically, electro-mechanically, or hydraulically energized. As shown, the anchors **52**, **54** may share a common actuator or each anchor **52**, **54** may have a dedicated actuator. The actuators may have a communication module **62** configured to receive control signals for operating the anchor assembly **50** and to transmit signals to the surface

- 7 -

(e.g., signals indicating the operating state or condition of the anchor assembly **50**).

[0013] Referring now to **Fig. 2**, there is shown in a sectional view the profiles **56**, **58** with which the anchors **52**, **54** (**Fig. 1**) engage. The profiles **56**, **58** may be formed on an inner surface **59** that defines a passage **61** of the liner assembly **26**.

[0014] In one embodiment, the profile **56** may be a recessed area formed in the inner surface **59** of the liner assembly **26** and that is shaped to allow the extension of the anchors **52** into the recessed area **61** in any circumferential orientation of the inner and outer component and to self-align the liner assembly **26** with the drill string **18** (**Fig. 1**). For instance, the ramp section **70** may protrude from the inner surface **59** and define a ramp surface that guides the anchor **52** to a predetermined alignment with a second component. The profile **56** may include a curved ramp section **70** and an axially aligned spline **72** (or load flank) that join at a juncture **74**. The spline **72** may be considered an axially aligned shoulder. The profile **56** may also include a circumferential groove **80** that is chamfered at the lower terminal end of the ramp section **70**. The curvature and surface defining the ramp section **70** are selected to present a helix-like structure against which the anchor **52** (**Fig. 1**) can slide toward the groove **80** in a manner that allows/causes the drill string **18** to rotate. In some arrangements, a ramp section, similar to ramp section **70**, can be formed on the anchor **52**.

[0015] In one non-limiting embodiment, a ramp tangent **91** forms an acute angle **91** with a longitudinal axis **95** of the anchor assembly **50**. The acute angle **91** may be between 1 degree and 90, between 1 degree and 70 degrees, or between 1 degree and less than 70 degrees. For surfaces that do not have a curvature, the ramp tangent may be the slope of the straight line defining the surface. The spline **72**, which is parallel with the longitudinal axis (or axis of symmetry), prevents further rotation in the direction the drill string **18** rotates while sliding along the splines **72** and moves toward the groove **80**. This

- 8 -

rotational direction is shown with arrow 76. Thus, torque transfer between the drill string 18 and the liner assembly 26 occurs at the spline 72 when the drill string is rotated in the direction shown by arrow 76. It should be noted that torque transfer in the opposite rotational direction can occur when the anchor 52 is positioned between the parallel shoulders 81 and 72 next to the groove 80. Axial loading from the drill string 18 to the liner assembly 26 occurs when the drill string 16 is axially displaced in the direction shown with arrow 78. Downward axial movement is stopped when the anchor 52 contacts the surfaces of the circumferential groove 80. The groove 80 may be partially or completely circumferential.

[0016] The sidewalls of the region 56 with the ramp 70 and the spline 72 and the groove 80 may have a stress optimized shape, that allows to transfer the loads axially and torsional and to withstand a predefined differential pressure during the later following cementing procedure or other applications. In one embodiment, the profile 58 may be a recessed area in an inner wall of the liner assembly 26 that is shaped as a circumferential groove with an endstop shoulder 90. The groove 90 may include a stress reducing multi-center point arc contour 92.

[0017] Referring to Figs. 3A-B, there is shown a section of a downhole tool 500 wherein shoulders 528 are formed. The shoulders 528 are separated by cavities 532, one of which is shown. An anchor 516, when moving in an axial direction, contacts and slides along a surface 530 that projects radially inward from a wall of the downhole tool 500. The surface 530 may be considered a "ramp." The axial direction may be the uphole or downhole direction. The surface 530 forces the anchor 516 to move along a pre-defined path as shown by line 516a. A wall 534 of a groove, which may be partially or completely circumferential, blocks further movement of the anchor 516 in the axial direction. Further, opposing surfaces 536a and 536b form side walls on which torque may be transmitted.

- 9 -

[0018] The contours or ramps of the present disclosure are susceptible to numerous variations. In some embodiments, one or more surfaces defining the ramp (or contour) may be non-linear. The non-linear surfaces may be defined by a radius, a mathematic relationship (e.g., a polynomial), or an arbitrary curvature. In some embodiments, one or more of the surfaces defining the ramp, may use straight lines. In some embodiments, the ramp may use a composite geometry using different types of non-linear surface and / or linear surfaces. For instances, the linear surfaces may use different slopes. Thus, the ramp contour may be defined by one or more curves, straight lines, different curves, straight lines having different slopes, and combinations of curves and straight lines.

[0019] FIGS 4A-B illustrate various configurations of anchors 52 and contours 56 according to the present disclosure. Fig. 4A illustrates profiles in an "unwrapped" form. Anchors 52 contact and slide along surfaces of the profiles 56. While three profiles 56 are shown, it should be understood that greater or fewer may be used. In FIG. 4A, there are shown a plurality of anchors 52 and associated contours 56. Thus, some embodiments may have one anchor and one contour and other embodiments may have more than one anchor and associated contour. FIG. 4B illustrates a "keyed" or "coded" configuration for an anchors 52 and contours 56. As a non-limiting example, there are two anchors 52 and two contours 56. Thus, an anchor assembly that has three or more anchors would not be able to mate or pass through the contours 56. Thus, using a mismatch of in the number of anchors and contours is one non-limiting way to selective mate anchors and contours.

[0020] The anchors of the present disclosure may be configured to principally transmit force in one or more selected modes (e.g., rotationally, axially, torque, compression, tension, etc.). As discussed below, the profile 56, in addition to providing a self-alignment function illustrated in Fig. 4A, can transfer torque and axial loading in selected directions (e.g., in the downhole direction to push the liner assembly 26 through a high friction zone or a horizontal section) between the drill string 18 and the liner assembly 26.

- 10 -

The profile **58** can transfer axial loadings principally in the uphole direction between the drill string **18** and the liner assembly **26**.

[0021] In one embodiment, a marker tube assembly **100** may be positioned between the profile **56** and the profile **58** or any location on the liner assembly **26**. The marker tube assembly **100** needs only to have a known or predetermined position relative to another location on the liner assembly **26**.

[0022] Referring to **Figs. 1** and **2**, in an illustrative mode of operation, the liner assembly **26** is positioned in the borehole **14**. Later, the drill string **18** is lowered into the passage **61** of the liner assembly **26**. Connecting the liner assembly **26** to the drill string **18** may require these two components to have a predetermined alignment, which may be a circumferential, radial and / or axial relative alignment.

[0023] The marker tube assembly **100** may be used to locate the torque profile **56**. In some embodiments, the profiles **58** may act as the grooves for the marker tube assembly **100**. At that time, the torque anchor **52** may be extended using a control signal sent from a surface location. Alternatively, the extension may occur during an automatic mode triggered by the marker tube downhole. In another variation, the marker itself is a predefined shaped liner contour that matches with the sliding anchor profile and allows the engagement only in this position where the inner and outer part acts as a key-lock mechanism.

[0024] Alternatively, if the anchors **52** are already extended or generally fixed, the number or circumferential position of the anchor(s) **52** can encode a certain position which can mate only to a similar counterpart as shown in **Fig. 4B**. That is, the anchor(s) **52** can only enter the profile(s) **56** if there is a predetermined rotational alignment.

[0025] With the torque anchor **52** extended, the drill string **18** is lowered (*i.e.*, moved in the downhole direction) until the torque anchor **52** contacts the ramp section **70**. Further lowering causes the drill string **18** to rotate until the

- 11 -

torque anchor **52** is seated at a shoulder of the groove **80**. At this point, the liner assembly **26** to the drill string **18** have the predetermined circumferential, radial and / or axial alignment. Further rotation of the drill string **18** can transmit torque to the liner assembly **26** via the physical contact between the torque anchor **52** and the spline **72**. Torque may also be transmitted using the shoulder **81**, depending on the rotating direction. As noted previously, this process may be done using personnel inputs or automatically.

[0026] With the drill string **18** and the liner assembly **26** now properly aligned, the weight anchors **54** can be extend since the weight profile **58** may be an entirely circumferential groove that allows the anchors **54** to be extended independently from any rotational position. Then we lift up the inner drill string **18** and the drill string **18** can be pulled in the uphole direction until the weight anchor **54** contacts the endstop shoulder **90** and physically engage the weight profile

[0027] Referring still to **Figs. 1** and **2**, in one exemplary mode of operation, the drill string **18** and the liner assembly **26** are tripped downhole and drilling commences. During this time, drill bit **20** forms the primary bore and the reamer **24** enlarges the primary bore. The anchor assembly **26** provides a physical engagement that allows the drills string **18** to pull or push the liner assembly **26** through the borehole **14**. During this time, the torque anchor **52** principally transmits the torque necessary to rotate the liner assembly **26** and transmits a downhole-oriented force to push the liner assembly **26** downhole. The weight anchor **54** principally transmits the forces necessary to keep the liner assembly **26** locked to the drill string **18** in the uphole axial direction. More generally, the weight anchors **54** transmits forces in an axial direction, which is generally along the borehole.

[0028] From the above, it should be appreciated that what has been described includes positioning, aligning, and orientating systems / methodologies that use matching between anchor and cavities lock and key functionality by number, shape, position. These systems eliminate the need

- 12 -

for rotatable orientation of the components being connected. Additionally, stress optimization in regards to applied load from axial forces, torsion I load and finally pressure rating for the differential pressure versus the remaining wall thickness. A tilted contact shoulder to optimize the transmission path of the axial weight.

**[0029]** It should be understood that the teachings of the present disclosure are not limited to any particular downhole application. Anchor assemblies of the present disclosure may also be used during completion, logging, workover, or production operations. In such applications, the components to be connected by a wireline, coiled tubing, production string, casing, or other suitable work string. One non-limiting application for the contours of the present disclosure relate to liner-drilling activities, which are described in greater detail below.

**[0030]** Turning now to **FIG. 5**, a schematic line diagram of an example string **200** that includes an inner string **210** disposed in an outer string **250** is shown. In this embodiment, the inner string **210** is adapted to pass through the outer string **250** and connect to the inside **250a** of the outer string **250** at a number of spaced apart locations (also referred to herein as the “landings” or “landing locations”). The shown embodiment of the outer string **250** includes three landings, namely a lower landing **252**, a middle landing **254** and an upper landing **256**. The inner string **210** includes a drilling assembly or disintegrating assembly **220** (also referred to as the “bottomhole assembly”) connected to a bottom end of a tubular member **201**, such as a string of jointed pipes or a coiled tubing. The drilling assembly **220** includes a first disintegrating device **202** (also referred to herein as a “pilot bit”) at its bottom end for drilling a borehole of a first size **292a** (also referred to herein as a “pilot hole”). The drilling assembly **220** further includes a steering device **204** that in some embodiments may include a number of force application members **205** configured to extend from the drilling assembly **220** to apply force on a wall **292a** of the pilot hole **292a** drilled by the pilot bit **202** to steer the pilot bit **202** along a selected direction, such as to drill a deviated pilot

- 13 -

hole. The drilling assembly **220** may also include a drilling motor **208** (also referred to as a “mud motor”) **208** configured to rotate the pilot bit **202** when a fluid **207** under pressure is supplied to the inner string **210**.

[0031] In the configuration of **FIG. 5**, the drilling assembly **220** is also shown to include an under reamer **212** that can be extended from and retracted toward a body of the drilling assembly **220**, as desired, to enlarge the pilot hole **292a** to form a wellbore **292b**, to at least the size of the outer string. In various embodiments, for example as shown, the drilling assembly **220** includes a number of sensors (collectively designated by numeral **209**) for providing signals relating to a number of downhole parameters, including, but not limited to, various properties or characteristics of a formation **295** and parameters relating to the operation of the string **200**. The drilling assembly **220** also includes a control circuit (also referred to as a “controller”) **224** that may include circuits **225** to condition the signals from the various sensors **209**, a processor **226**, such as a microprocessor, a data storage device **227**, such as a solid-state memory, and programs **228** accessible to the processor **226** for executing instructions contained in the programs **228**. The controller **224** communicates with a surface controller (not shown) via a suitable telemetry device **229a** that provides two-way communication between the inner string **210** and the surface controller. Furthermore, a two-way communication can be configured or installed between subcomponents of multiple parts of the BHA. The telemetry device **229a** may utilize any suitable data communication technique, including, but not limited to, mud pulse telemetry, acoustic telemetry, electromagnetic telemetry, and wired pipe. A power generation unit **229b** in the inner string **210** provides electrical power to the various components in the inner string **210**, including the sensors **209** and other components in the drilling assembly **220**. The drilling assembly **220** also may include a second or multiple power generation devices **223** capable of providing electrical power independent from the presence of the power generated using the drilling fluid **207** (e.g., third power generation device **240b** described below).

- 14 -

[0032] In various embodiments, such as that shown, the inner string **210** may further include a sealing device **230** (also referred to as a “seal sub”) that may include a sealing element **232**, such as an expandable and retractable packer, configured to provide a fluid seal between the inner string **210** and the outer string **250** when the sealing element **232** is activated to be in an expanded state. Additionally, the inner string **210** may include a liner drive sub **236** that includes attachment elements **236a**, **236b** (e.g., latching elements or anchors) that may be removably connected to any of the landing locations in the outer string **250**. The inner string **210** may further include a hanger activation device or sub **238** having seal members **238a**, **238b** configured to activate a rotatable hanger **270** in the outer string **250**. The inner string **210** may include a third power generation device **240b**, such as a turbine-driven device, operated by the fluid **207** flowing through the inner string **210** configured to generate electric power, and a second two-way telemetry device **240a** utilizing any suitable communication technique, including, but not limited to, mud pulse, acoustic, electromagnetic and wired pipe telemetry. The inner string **210** may further include a fourth power generation device **241**, independent from the presence of a power generation source using drilling fluid **207**, such as batteries. The inner string **210** may further include pup joints **244**, a burst sub **246**, and other components, such as, but not limited to, a release sub that releases parts of the BHA on demand or at reaching predefined load conditions.

[0033] Still referring to **FIG. 5**, the outer string **250** includes a liner **280** that may house or contain a second disintegrating device **251** (e.g., also referred to herein as a reamer bit) at its lower end thereof. The reamer bit **251** is configured to enlarge a leftover portion of hole **292a** made by the pilot bit **202**. In aspects, attaching the inner string at the lower landing **252** enables the inner string **210** to drill the pilot hole **292a** and the under reamer **212** to enlarge it to the borehole of size **292** that is at least as large as the outer string **250**. Attaching the inner string **210** at the middle landing **254** enables the reamer bit **251** to enlarge the section of the hole **292a** not enlarged by the

- 15 -

under reamer **212** (also referred to herein as the “leftover hole” or the “remaining pilot hole”). Attaching the inner string **210** at the upper landing **256**, enables cementing an annulus **287** between the liner **280** and the formation **295** without pulling the inner string **210** to the surface, i.e., in a single trip of the string **200** downhole. The lower landing **252** includes a female spline **252a** and a collet groove **252b** for attaching to the attachment elements **236a** and **236b** of the liner drive sub **236**. Similarly, the middle landing **254** includes a female spline **254a** and a collet groove **254b** and the upper landing **256** includes a female spline **256a** and a collet groove **256b**. Any other suitable attaching and/or latching mechanisms for connecting the inner string **210** to the outer string **250** may be utilized for the purpose of this disclosure.

[0034] The outer string **250** may further include a flow control device **262**, such as a flapper valve, placed on the inside **250a** of the outer string **250** proximate to its lower end **253**. In **FIG. 2**, the flow control device **262** is in a deactivated or open position. In such a position, the flow control device **262** allows fluid communication between the wellbore **292** and the inside **250a** of the outer string **250**. In some embodiments, the flow control device **262** can be activated (i.e., closed) when the pilot bit **202** is retrieved inside the outer string **250** to prevent fluid communication from the wellbore **292** to the inside **250a** of the outer string **250**. The flow control device **262** is deactivated (i.e., opened) when the pilot bit **202** is extended outside the outer string **250**. In one aspect, the force application members **205** or another suitable device may be configured to activate the flow control device **262**.

[0035] A reverse flow control device **266**, such as a reverse flapper valve, also may be provided to prevent fluid communication from the inside of the outer string **250** to locations below the reverse flow control device **266**. The outer string **250** also includes a hanger **270** that may be activated by the hanger activation sub **238** to anchor the outer string **250** to the host casing **290**. The host casing **290** is deployed in the wellbore **292** prior to drilling the wellbore **292** with the string **200**. In one aspect, the outer string **250** includes a

- 16 -

sealing device **285** to provide a seal between the outer string **250** and the host casing **290**. The outer string **250** further includes a receptacle **284** at its upper end that may include a protection sleeve **281** having a female spline **282a** and a collet groove **282b**. A debris barrier **283** may also be part of the outer string to prevent cuttings made by the pilot bit **202**, the under reamer **212**, and/or the reamer bit **251** from entering the space or annulus between the inner string **210** and the outer string **250**.

[0036] To drill the wellbore **292**, the inner string **210** is placed inside the outer string **250** and attached to the outer string **250** at the lower landing **252** by activating the attachment elements **236a**, **236b** of the liner drive sub **236** as shown. This liner drive sub **236**, when activated, connects the attachment element **236a** to the female splines **252a** and the attachment element **236b** to the collet groove **252b** in the lower landing **252**. In this configuration, the pilot bit **202** and the under reamer **212** extend past the reamer bit **251**. In operation, the drilling fluid **207** powers the drilling motor **208** that rotates the pilot bit **202** to cause it to drill the pilot hole **292a** while the under reamer **212** enlarges the pilot hole **292a** to the diameter of the wellbore **292**. The pilot bit **202** and the under reamer **212** may also be rotated by rotating the drill string **200**, in addition to rotating them by the motor **208**.

[0037] In general, there are three different configurations and/or operations that are carried out with the string **200**: drilling, reaming and cementing. In drilling a position the Bottom Hole Assembly (BHA) sticks out completely of the liner for enabling the full measuring and steering capability (e.g., as shown in **FIG. 5**). In a reaming position, only the first disintegrating device (e.g., pilot bit **202**) is outside the liner to reduce the risk of stuck pipe or drill string in case of well collapse and the remainder of the BHA is housed within the outer string **250**. In a cementing position the BHA is configured inside the outer string **250** a certain distance from the second disintegrating device (e.g., reamer bit **251**) to ensure a proper shoe track.

- 17 -

[0038] As provided herein, one-trip drilling and reaming operations are carried out with a BHA capable of being repositioned in a liner for the drilling of the pilot hole and the subsequent reaming. In some embodiments, fully circular magnetic rings in the liner and/or the running tool provide surface information as to a position of a running tool with respect to the liner when reconnecting to the liner. Further, position sensors can confirm alignment to various recesses in the liner for attachment. Axial loads can be transmitted through the liner at spaced locations separate from torsional loads with the attachment elements (e.g., blade arrays, anchors, etc.) spaced out on the running tool. In some embodiments, an emergency release can retract the blades from the opposing recesses to allow the running tool to be removed while opening the tool for flow. Proximity sensors in conjunction with the electromagnetic field sensed by the running tool allows alignment between the blades and the liner recesses. Blades are link driven with the link having offset centers to reduce stress.

[0039] The running tool provides the connection between the inner string and the liner during steerable liner drilling. This connection, in accordance with embodiments of the present disclosure, can be infinitely engaged and released via downlinks. In some embodiments, the connection can also be established at different positions within the liner, depending on the operation that is being performed. The connection, as provided in accordance with various embodiments of the present disclosure, can be realized by the use of engagement modules (including, e.g., in one non-limiting embodiment, blade-shaped anchors) that are designed to transmit rotational forces from an over ground turning device (e.g., top drive) to the liner. The blade-shaped anchors can support both axial forces (e.g., liner weight or pushing forces acting on the liner to overcome, for example, high friction zones, etc.) and the rotational reaction forces due to the liner/formation interaction. The liner, in accordance with various embodiments, can include inner contours in order to host or receive the anchors. In summary, a downlink activated

- 18 -

connection/transmission (e.g., the anchors) is optimized to handle or manage high loads.

**[0040]** Running tools as provided herein enable systems that combine drilling, reaming, liner setting, and cementing processes into a single run. The processes of setting a liner and cementing during a single trip demands for a frequent liner-drill/cementing-string connect/disconnect procedure. Running tools as provided herein can accomplish such operation through incorporation of a set of limitless extendable and retractable anchors that support and transmit axial forces (e.g., liner weight or pushing forces acting on the liner to overcome, for example, high friction zones, etc.) and torque. In some embodiments, torque anchors configured to transmit torque and/or apply pushing forces to the liner are physically or spatially separated from weight anchors configured to support the liner weight. The liner is configured with associated inner contours in order to house or receive the anchors. The number of anchors located on or at each module (e.g., torque anchor module, weight anchor module) can be different. Such difference in number(s), shape, size, latching and/or contact faces, etc. can be provided to insure proper latching and to avoid misfits.

**[0041]** Running tools as provided herein can be used for running cycles. One non-limiting running cycle is as follows. In order to start a new operation (such as rathole reaming or cementing) the running tool disengages. Such disengagement can be, for example, initiated or caused by a downlink and instructions or commands transmitted from the surface, triggered by internal tool sub routines, or started by gathering downhole information that reaches pre-selected thresholds. The running tool is moved to and confirms a new position within the liner. In some embodiments, the location of the running tool can be detected by a position detection system. The position detection system includes a marker and a position sensor. By way of a non-limiting example, the position may be measured by a magnetic marker/Hall sensor combination, gamma marker/detector, liner contour/acoustic sensor, or other marker/detector combination, as known in the art. At the new location, the

- 19 -

running tool re-engages to the liner. The engagement can be caused by a downlink, triggered by internal tool sub routines, or started by gathering downhole information that reaches pre-selected thresholds. The above noted inner contours on the liner can be used for self-alignment of the running tool by engagement with the anchors. The movement and engagement amount of the anchors can be monitored, confirmed, and measured by an LVDT (linear variable differential transformer) or any inductive, capacitive, or magnetic sensor system and sent to the surface for confirmation. As such, a downhole operation can be continued with the running tool being connected to the liner at a different location than prior to movement of the running tool.

**[0042]** The above described position detection system may additionally include, in some embodiments, an acoustic sensor which is configured to detect an inner contour of the liner. In such configurations, identifying the location of the running tool inside the liner may be done by correlating the depth of the running tool and the inner contour of the liner.

**[0043]** The running tool is subject to very high forces and torques due to both its position within the drill string and the presence of the liner. By way of non-limiting example, the transmission of the torque and the axial forces from the inner string to the liner are separated in order to handle those high loads (e.g., separate torque-anchor and weight-anchor modules with separate associated anchors). In some embodiments, a complex geometry supports the weight/torque transmission. In some embodiments, the anchors are extended (or deployed) by default such that the liner cannot be lost downhole during a power/communication loss. In some non-limiting embodiments, the extending or deploying force applied to the anchors can be provided by coil springs. If power/communication cannot be re-established and the drill string is to be retrieved without the liner, the anchors can be permanently retracted by the use of a drop ball. In such an embodiment, the ball can activate a purely mechanical release mechanism powered by a circulating drilling fluid to thus retract the anchors. In some embodiments, the anchors can be pulled in by pulling the anchors against a contact surface to force the anchors to collapse

- 20 -

inward and lose engagement between the running tool and the liner. While drop balls are used in the described embodiment of the present disclosure, the term “drop ball” also includes any other suitable object, e.g., bars, darts, plugs, and the like.

[0044] FIGS. 6A-6C illustrate various views of a liner 300 supported by a running tool 302 are shown. FIG. 6A is a side view illustration of the liner and running tool 300. FIG. 6B is a cross-sectional illustration of the liner 300 and running tool 302 as viewed along the line B-B of FIG. 6A and FIG. 6C a cross-sectional illustration of the liner 300 and running tool 302 as viewed along the line C-C of FIG. 6A.

[0045] The running tool 302 is configured on and along a string 304. The inner string 304 extends up-hole (e.g., to the left in FIG. 6A) and down-hole (e.g., to the right in FIG. 6A). Down-hole relative to the running tool 302 is a bottom hole assembly (BHA) 306. The BHA 306 can be configured and include components as described above.

[0046] To enable interaction between the liner 300 and the running tool 302, as provided in accordance with some embodiments of the present disclosure, the liner 300 includes one or more running tool engagement sections 307. As shown, the running tool engagement section 307 includes a first liner anchor cavity 308 and a second liner anchor cavity 310 that are defined as recesses or cavities formed on an interior surface of the liner 300. The liner anchor cavities 308, 310 can be axially spaced along a length of the liner 300 and/or they can be spaced in an appropriate spacing around the tool axis (e.g., equally spaced). That is, the liner anchor cavities 308, 310 are located at different positions along the length of the liner 300. The liner anchor cavities 308, 310 are sized and shaped to receive portions of the running tool 302. The liner 300 can include multiple running tool engagement sections 307 located at different distances or positions relative to a bottom end of a bore hole, and thus can enable extension of a BHA from the end of the liner to different lengths, as described herein. The running tool engagement section

- 21 -

**307** need not include all the liner anchor cavities **308**, **310**, or, in other configurations, additional cavities can be provided in and/or along the liner or elsewhere as will be appreciated by those of skill in the art.

[0047] As shown, the running tool **302** may include a first engagement module **312** and a second engagement module **314** (also referred to as anchor modules). The first and second engagement modules **312**, **314** are spaced apart from each other along the length of the running tool **302**. The first liner anchor cavity **308** of the liner **300** is configured to receive one or more anchors of the first anchor module **312** and the second liner anchor cavity **310** of the liner **300** is configured to receive one or more anchors of the second anchor module **314**. Accordingly, the spacing of the liner anchor cavities **308**, **310** along the liner **300** and the spacing of the anchor modules **312**, **314** can be set to allow interaction of the respective features.

[0048] The first anchor module **312** includes one or more first anchors **316** and the second anchor module **314** includes one or more second anchors **318**. The anchors **316**, **318** can be spaced in an appropriate spacing around the tool axis, also referred to as circumferentially spaced, and in a longitudinal direction, also referred to as axial direction or axially spaced along the length of the liner or running tool (e.g., equally spaced or unequally spaced). As shown in **FIG. 6B**, by way of non-limiting example, the first anchor module **312** includes three first anchors **316**. Further, as shown in **FIG. 6C**, the second anchor module **314** includes five second anchors **318**. The anchors **316**, **318** of the anchor modules **312**, **314** can be configured as blades or other structures as known in the art. The anchors **316**, **318** are configured to be deployable or expandable to extend outward from an exterior surface of the respective module **312**, **314** and engage into a respective liner anchor cavity **308**, **310**. Further, the anchors **316**, **318** are configured to be retractable or closable to pull into the respective module **316**, **318**, and thus disengage from the respective module **316**, **318**, which enables or allows movement of the running tool **302** relative to the liner **300**. Although shown with particular example numbers of anchors in each anchor module, those of skill in the art will

- 22 -

appreciate that any number of anchors can be configured in each of the anchor modules without departing from the scope of the present disclosure.

**[0049]** The engagement or anchor modules **312**, **314** are actuatable or operational such that the anchors or other engagable elements or features are moveable relative to the module. For example, anchors of the engagement modules can be electrically, mechanically, hydraulically, or otherwise operated to move the anchor relative to the module (e.g., radially outward from a cylindrical body). The engagement modules may be operated by combined methods, such as electro-hydraulically or electro-mechanically. In various embodiments, such as those previously mentioned, an electronics module, electronic components, and/or electronics device(s) can be used to operate the engagement module, including, but not limited to electrically driven hydraulic pumps or motors. In the simplest configuration, the electronics device can be an electrical wire, e.g., to transmit a signal, but more sophisticated components and/or modules can be employed without departing from the scope of the present disclosure. As used herein, an electronics module may be the most sophisticated electronic configuration, with electronic components either less sophisticated and/or subparts of an electronics module and an electronic device being the most basic electronic device (e.g., an electrical wire, hydraulic pump, motor, etc.). The electronic device can be a single electrical/electronic feature of the system taken alone or may be part of an electronics component and/or part of an electronics module.

**[0050]** Movement of the anchors may also be axial, tangential, or circumferential relative to a cylindrical module body. Actuation or operation of the engagement modules, as used herein, can be an operation that is controlled from a surface controller or can be an operation of the anchors to engage or disengage from a surface or structure in response to a pre-selected or pre-determined event or detection of pre-selected conditions or events. In some embodiments, the actuation or operation of each anchor module can be independent from the other anchor modules. In other embodiments, the

- 23 -

actuation or operation of different anchor modules can be a dependent or predetermined sequence of actuations.

**[0051]** In some embodiments (depending on the module configuration) actuation can mean extension from the module into engagement with a surface that is exterior to the module (e.g., an interior surface of a liner) and/or disengagement from such surface. That is, operation/actuation can mean extension or retraction of anchors into or from engagement with a surface or structure. As noted above, in some non-limiting embodiments, the different anchors may be operated separately or collectively. The separate or collective operation can be referred to as dependent or independent operation. In the case of independent operation, for example, only a single anchor may be extended or retracted, or a particular set or number of anchors may be extended or retracted. Further, for example, a particular time-based sequence of particular or predetermined anchor extensions or retractions can be performed in order to engage or disengage with the liner.

**[0052]** In some embodiments, the first anchors **316** of the first module **312** can be configured to transmit torque in either direction (e.g., circumferentially) with respect to the running tool **302** or the string **304**. In such a configuration, the first anchors **316** may be referred to as torque anchors and the first module **312** may be referred to as a torque anchor module. The shape of the torque anchors can allow torque transmission to the liner or liner components as well as transmitting axial forces in a downhole direction. The capability of applying axial forces in the downhole direction can be used for pushing the liner through high friction zones, to influence the set down weight of the reamer bit, to activate or to support the setting of a hanger or packer, or to activate other liner components and/or completion equipment.

**[0053]** The second anchors **318** of the second module **314** can be configured to transmit axial forces in an uphole direction. The capability of applying axial forces in the uphole direction can be used for carrying the liner

- 24 -

weight and therefor to influence a set down weight of the reamer bit, to activate or to support the setting of a hanger or packer, or to activate or shear off other liner components. In such a configuration, the second anchors **318** may be referred to as weight anchors and the second module **314** may be referred to as a weight anchor module. In one non-limiting example, the second module **314** can be configured to apply set down weight to a drill bit or reamer bit and instrumentation BHA **306** for directional drilling. The string **304** continues to the surface as indicated on the left side of **FIG. 6A**. Those of skill in the art will appreciate that torque anchors push the liner when weight is applied and weight anchors hold the liner or pull the liner when the string is pulled.

[0054] As noted, the first anchors **316** and the second anchors **318** are selectively extendable into locations on the liner **300** (e.g., liner anchor cavities **308**, **310**). The liner **300** can be configured with repeated configurations of liner anchor cavities **308**, **310**, which can enable engagement of the running tool **302** with the liner **300** at multiple locations along the length of the liner **300**. The anchors **316**, **318** can latch into engagement with the liner anchor cavities **308**, **310** to provide secured contact and engagement between the running tool **302** and the liner **300**.

[0055] One advantage enabled by engagement of the running tool **302** at different locations along the length of the liner **300** is to have different extensions of the BHA **306** from the lower end of the liner **300** when drilling a pilot hole as opposed to reaming the pilot hole already drilled. For example, for directional drilling of a pilot hole the BHA **306** extends out more from the lower end of the liner **300** and so the running tool can be engaged at a lower (e.g., down-hole) position relative to the liner **300** than when a reamer bit is enlarging a pilot hole.

[0056] Because of the separation of the first and second modules **312**, **314**, the application of torque can be separated from the application of axial weight on a bit. Accordingly, stress at or on the anchors **316**, **318** and/or the

- 25 -

respective modules **312**, **314** when drilling and reaming a deviated borehole can be reduced. In accordance with embodiments of the present disclosure, the anchors **316**, **318** are configured to fit in respective liner anchor cavities **308**, **310**. Pairs of liner anchor cavities **308**, **310** are located on the liner **300** at different locations with appropriate spacing relative to each other so that the anchors **316**, **318** can be engaged at different locations along the liner **300** and, thus, different extensions of BHA **306** from the lower end of the liner **300** can be achieved. That is, in some embodiments, the distance between each first liner anchor cavity **308** and each second liner anchor cavity **310** of each pair of liner anchor cavities is constant. In other embodiments, the spacing may not be constant. Further, in some embodiments, the shape of a cavity along a length of a string can be different at different positions. Because the running tool **302** can be moved and located at different positions within the liner **300**, and such position can be indicative of an extension of the BHA **306**, it may be desirable to monitor the position of the running tool **302** within the liner **300**.

[0057] In some embodiments, to enable position monitoring and/or controlled operation and/or automatic operations, the running tool **302** can include one or more electronics modules **319**. The electronics module **319** can include one or more electronic components, as known in the art, to enable control of the running tool **300**, such as determining the engaging and disengaging, and/or enable communication with the surface and/or with other downhole components, including, but not limited to, the BHA **306**. The electronics module **319** can be part of or form a downlink that enables operation as describe herein. In other configurations, the electronics module **319** can be replaced by an electronics device, such as an electrical wire, that enables transmission of electrical signals to and/or from the running tool **302**.

[0058] Turning now to **FIGS. 7A-7B**, schematic illustrations of a liner **400** having a liner part (e.g., position marker **420**) that is part of a position detection system **425** in accordance with an embodiment of the present disclosure are shown. Although shown and described in **FIGS. 7A-7B** with various specific components configured in and on the running tool **402** and the

- 26 -

liner **400**, those of skill in the art will appreciate that alternative configurations with the presently described components located within a liner are possible without departing from the scope of the present disclosure. In the non-limiting example, such as that shown in **FIGS. 7A-7B**, the liner part of the position detection system **425** is a magnetic marker.

[0059] That is, the position detection system **425** can be configured on the liners (liner **400**) or running tools (running tool **402**) of embodiments of the present disclosure, such as liner **300** or running tool **302** of **FIG. 6A**. In accordance with the embodiment of **FIGS. 7A-7B**, a position marker **420** is based on a magnetic ring configuration that is installed with the liner **400**. However, the marker may also be located in the running tool **302**. Those of skill in the art will appreciate that the position marker **420** can take any number of configurations without departing from the scope of the present disclosure. For example, magnetic markers, gamma markers, capacitive marker, conductive markers, tactile/mechanical components, etc. can be used to determine relative position between the liner and the running tool (e.g., in an axial and/or rotational manner to each other) and thus comprise one or more features of a position marker in accordance with the present disclosure. As shown, the marker is placed on the outside liner part and a sensor **427** of the detection system **425** is placed in the running tool **402**. The sensor **427** is coupled to downhole electronics **419** within the running tool **402** (e.g., part of an electronics module, downlink, etc.). A sensor **427** can be a Hall sensor that detects the appearance and strength of a magnetic field. The downhole electronics **419** can be one or more electronic components that are configured in or on the running tool **402**, and can be part of an electronics module (e.g., electronics module **319** of **FIG. 6A**). In other embodiments, an electronics device (e.g., an electrical wire) can be used instead of the downhole electronics **419**.

[0060] **FIG. 7A** is a cross-sectional illustration of a portion of the liner **400** including the position marker **420** in accordance with an embodiment of the

- 27 -

present disclosure. **FIG. 7B** is an enlarged illustration of the position marker **420** as indicated by the dashed circle in **FIG. 7A**.

[0061] In some embodiments, the position detection system **425** can be operably connected to or otherwise in communication with downhole electronics **419** of the running tool **402** (e.g., in some embodiments, electronics module **319** of **FIG. 6A**). The downhole electronics **419** of the running tool **402** can be used to communicate information to the surface, such as the position that is detected by the position detection system **425**.

[0062] Properly engaging, disengaging, and moving the running tool **402** relative to the liner **400** is achieved through knowledge of the relative positions of the running tool **402** and the liner **400**. By knowing the relative position of the liner **400** and the running tool **402**, the anchor modules, described above, can be appropriately engaged with corresponding liner anchor cavities at different locations and thus adjustment of an extension of a BHA can be achieved. For example, the position detected by the position detection system **425** can be communicated to the surface to inform about the approximate location of the liner anchor cavity pairs relative to respective anchor modules.

[0063] In the embodiment shown in **FIGS. 7A-7B**, the position marker **420** includes a magnetic ring **422** that has opposed north and south poles **424**, **426** as shown. In other embodiments the opposite or differing pole orientation than that shown can be used. The magnetic ring **422**, in some embodiments, can be a full **360** degrees (e.g., wrap around the liner **400**) or, in other embodiments, the magnetic ring **422** can be split such that less than **360** degrees is covered by the magnetic ring **422**. Further, in other embodiments, the magnetic ring **422** can have overlapping ends such that the magnetic ring **422** wraps around more than **360°** of the liner **400**. Further still, other configurations can employ spaced magnetic buttons that form the position marker **420**.

- 28 -

[0064] The magnetic ring **422** of the position marker **420** creates an easily detected magnetic field that can be detected and/or interact with components or features of the liner or the running tool, depending on the particular configuration. Further, advantageously, position marker **420** as shown in **FIGS. 7A-7B** (e.g., magnetic rings **422**) can make the orientation of the running tool **402** in and relative to a liner irrelevant in detection of a signal. Accordingly, detection of the location of a liner anchor cavity can be easily achieved, e.g., by another magnetic component located on the liner. Detection can be achieved, in part, by processing carried out on an electronics module, and such detection can be communicated to the surface. Once the detection is communicated to the surface that a magnetic marker is detected, it may be desirable to position the running tool **402** with precision so that extension of the anchors of the first and/or second anchor modules engage within respective liner anchor cavities (as described above).

[0065] The foregoing description is directed to particular embodiments of the present disclosure for the purpose of illustration and explanation. It will be apparent, however, to one skilled in the art that many modifications and changes to the embodiment set forth above are possible without departing from the scope of the disclosure. It is intended that the following claims be interpreted to embrace all such modifications and changes.

## THE CLAIMS

What is claimed is:

1. A well tool in a well operation, comprising: a first component; and a second component having a passage for receiving the first component, the well tool characterized by:

at least one anchor (52, 54) on the first component, and

at least one profile (56, 58) formed on an inner surface (59) defining the passage of the second component and configured to receive the at least one anchor (52, 54), wherein at least one of the at least one profile (56, 58) and the at least one anchor (52, 54) includes a ramp section (70), the ramp section (70) having a ramp contour defined by a ramp tangent, the ramp tangent forming an acute angle (91) with a longitudinal axis of the borehole, the acute angle (91) of the ramp tangent being larger than 1 degree and smaller than 90 degrees.

2. The well tool of claim 1, further characterized in that the ramp section (70) protrudes from the inner surface (59) of the second component, the protruding ramp section (70) defining a ramp surface configured to guide the at least one anchor (52, 54) to a predetermined alignment with the second component.

3. The well tool of claim 2, further characterized in that the predetermined alignment is a circumferential alignment.

4. The well tool of claim 1, further characterized in that the ramp contour is defined by at least one of: (i) a curve, (ii) a straight line, (iii) a plurality of different curves, (iv) a plurality of straight lines having different slopes, and (v) a combination of at least one curve and at least one straight line.

- 30 -

5. The well tool of claim 1, further characterized in that the at least one profile (56, 58) in the second component comprises at least one cavity that receives the at least one anchor (52, 54).

6. The well tool of claim 1, further characterized in that the at least one anchor (52, 54) including a radially extending member that is one of: (i) fixed, and (ii) retractable.

7. The well tool of claim 1, further characterized in that the first component has a plurality of anchors (52, 54) and the second component has a plurality of associated profiles (56, 58).

8. The well tool of claim 7, further characterized in that the plurality of anchors (52, 54) comprises at least one of a weight anchor and a torque anchor.

9. The well tool of claim 1, further characterized in that the first component is a drill string (18) and the second component is a liner assembly (26).

10. The well tool of claim 1, further characterized in that the at least one profile (56, 58) includes a first shoulder (81), the first shoulder (81) is oriented substantially circumferentially in relation to the longitudinal axis of the borehole, the first shoulder (81) is configured to engage the at least one anchor (52, 54), the at least one anchor (52, 54) applying an axial loading to the substantially circumferentially oriented first shoulder (81) .

11. The well tool of claim 1, further characterized in that the at least one profile (56, 58) includes a second shoulder (72), the second shoulder (72) is oriented substantially axially in relation to the longitudinal axis of the borehole, the at least one anchor (52, 54) applying a torque loading to the substantially axially oriented second shoulder (72).

12. The well tool of claim 1, further characterized in that the acute angle (91) is smaller than 50 degrees.

- 31 -

13. A method for performing an operation using a well tool that has a first component and a second component, characterized by:

forming at least one profile (56, 58) in the second component, the at least one profile (56, 58) including a ramped section, the ramp section (70) having a ramp contour defined by a ramp tangent, the ramp tangent forming an acute angle (91) with a longitudinal axis of the borehole, the acute angle (91) of the ramp tangent being larger than 1 degree and smaller than 90 degrees;

disposing at least one anchor (52, 54) in the first component; and

axially moving the first component relative to the second component until the at least one anchor (52, 54) and the at least one profile (56, 58) align the first component and the second component in a predetermined alignment.

14. The method of claim 13, further comprising guiding the at least one anchor (52, 54) to a predetermined alignment with the second component using the ramp section (70).

15. The method of claim 13, further characterized in that a circumferentially oriented shoulder at least partially circumscribes the second component and further comprising applying an axial loading to the circumferentially oriented shoulder using the at least one anchor (52, 54)..

1/7

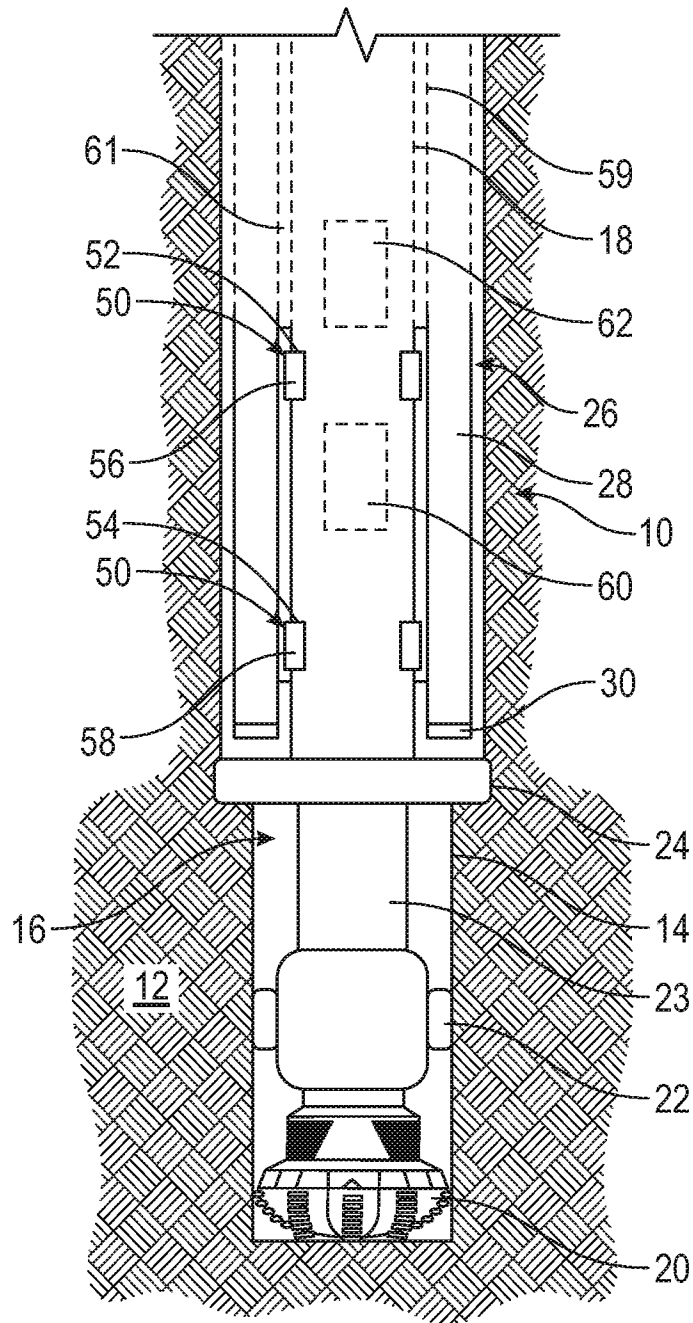

FIG. 1

2/7

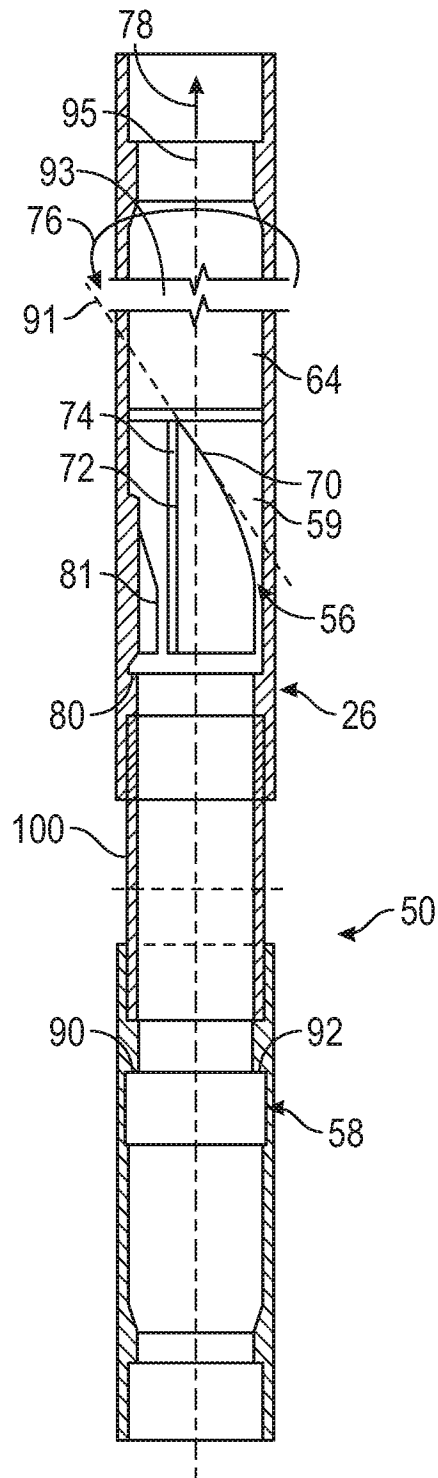

FIG. 2

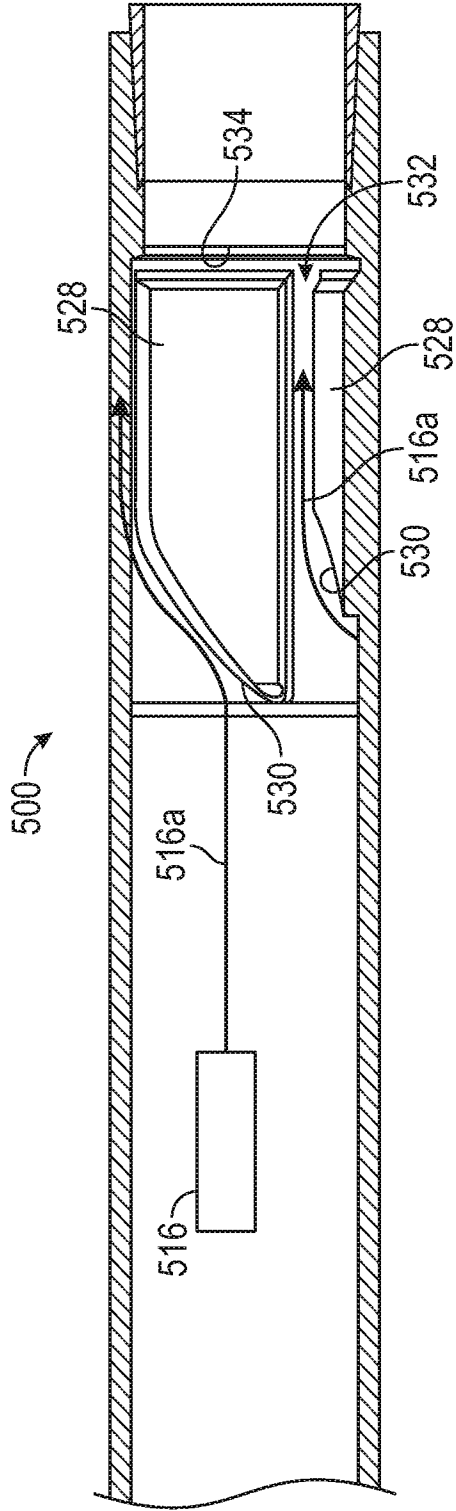

FIG. 3A

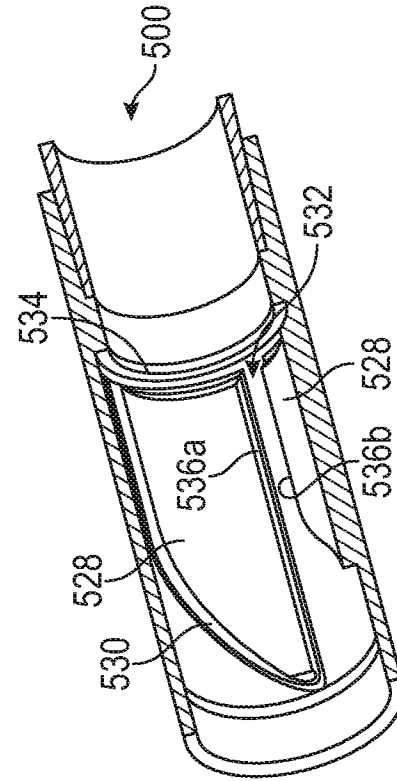

FIG. 3B

4/7

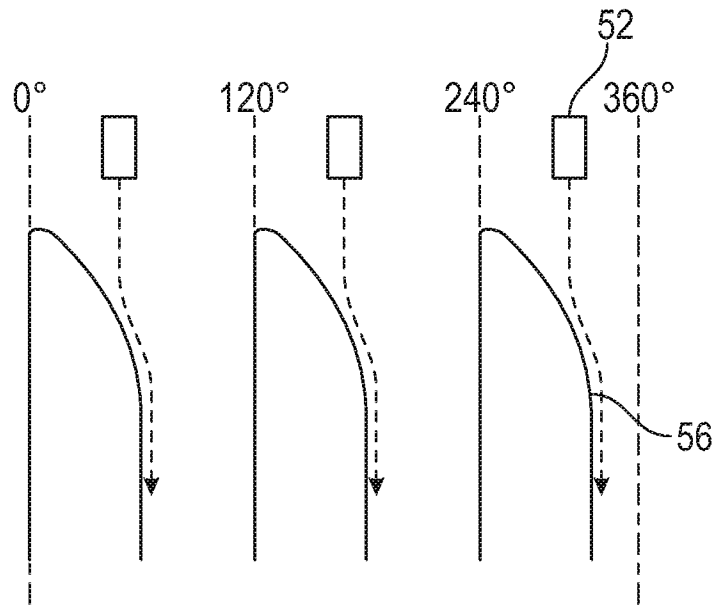

FIG. 4A

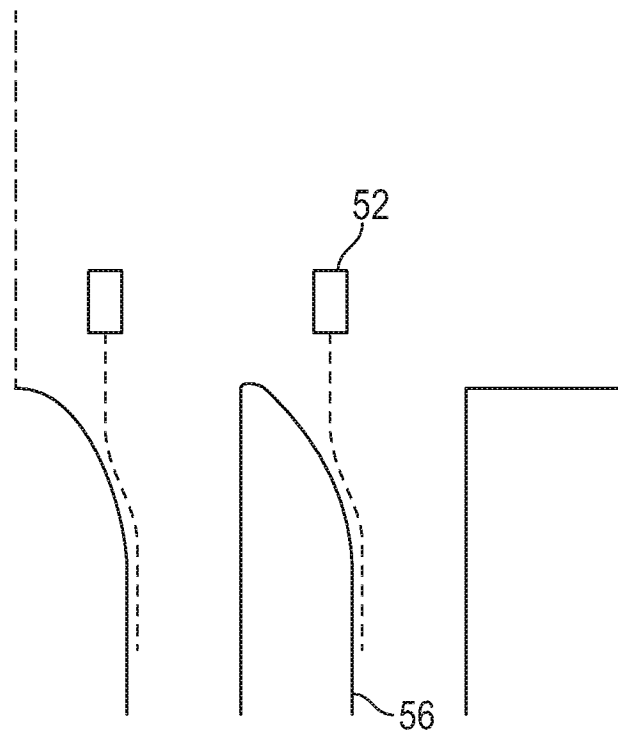

FIG. 4B

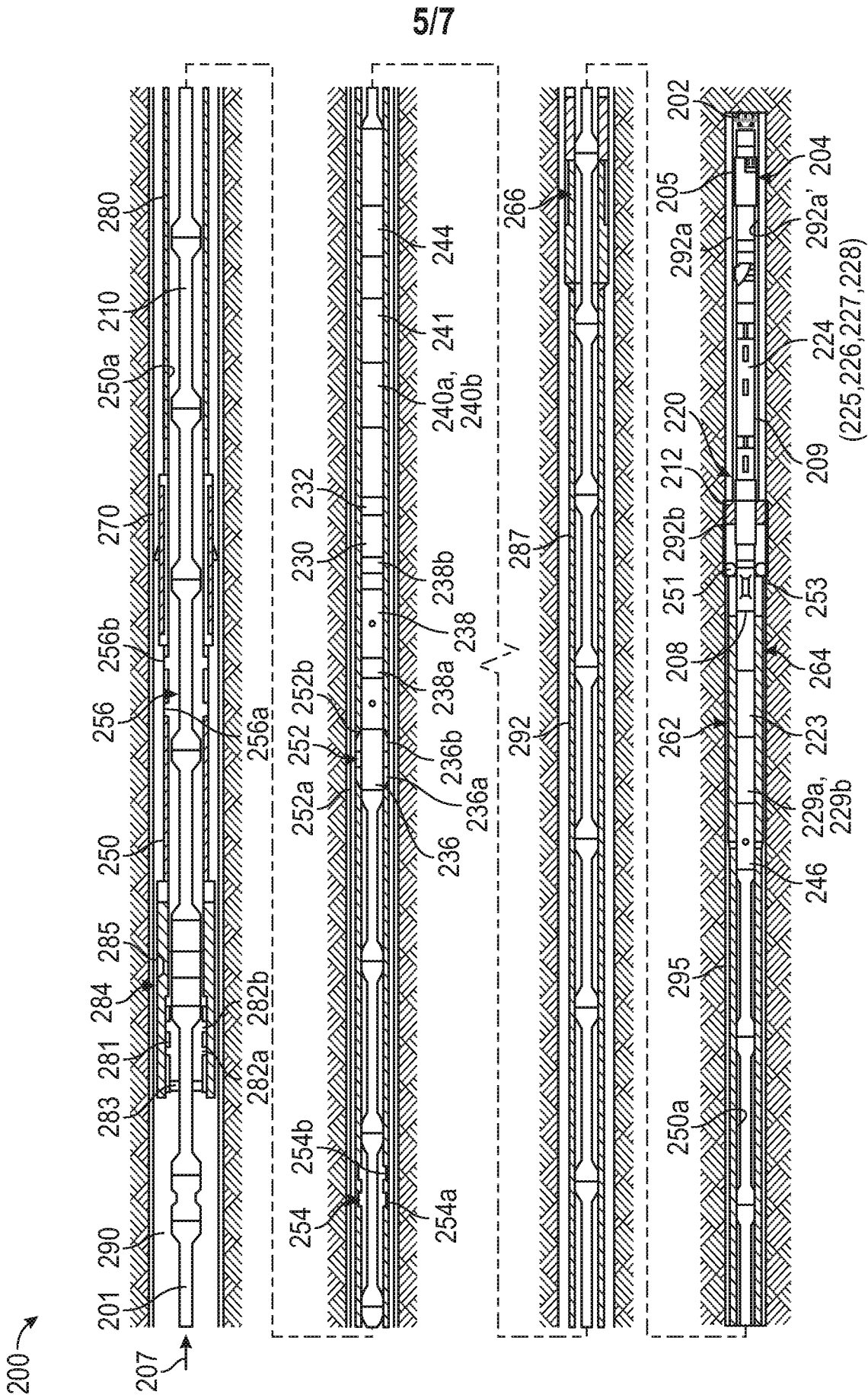

FIG. 5

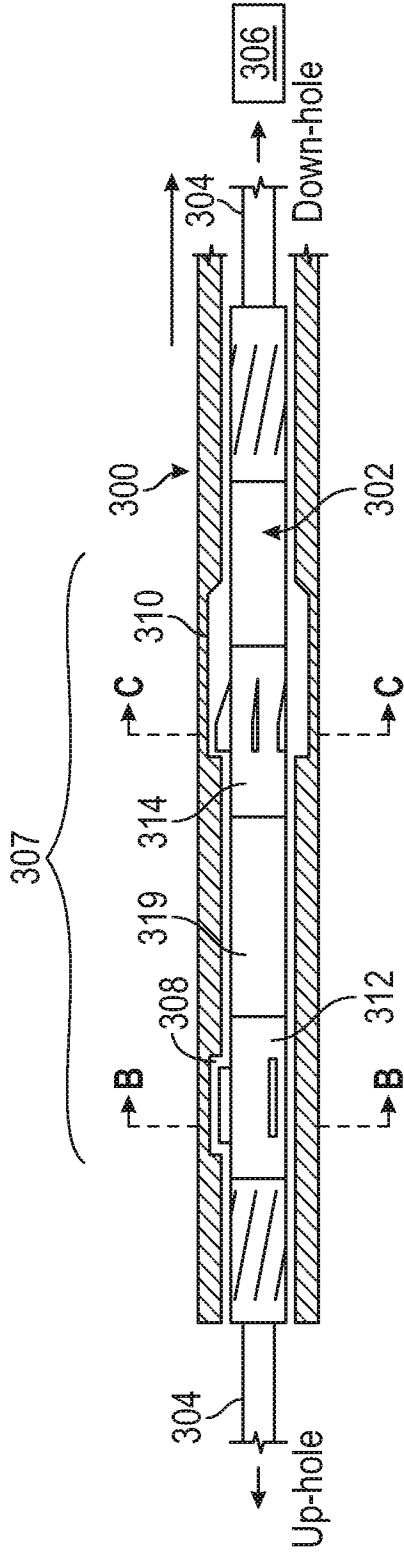

FIG. 6A

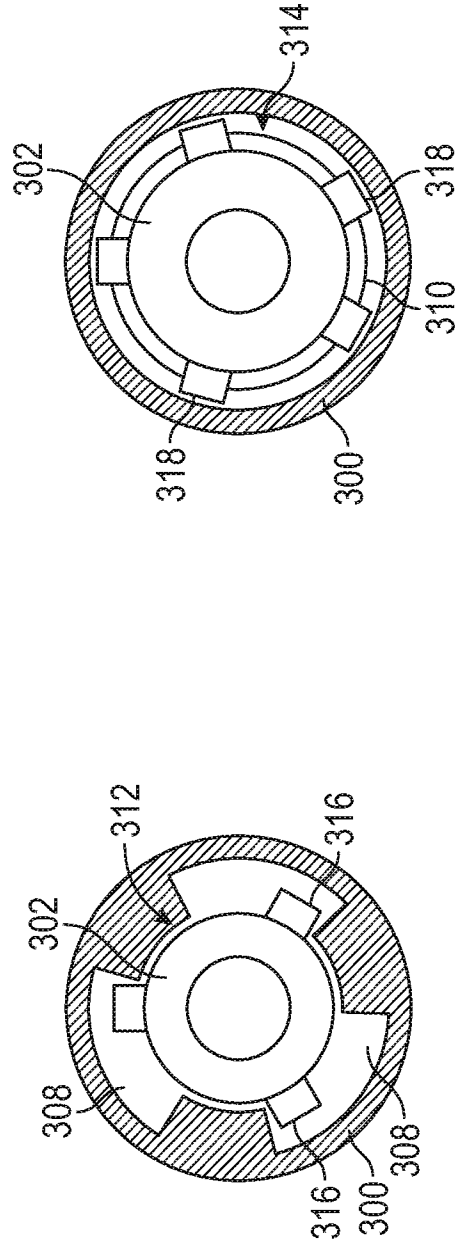

FIG. 6B

FIG. 6C

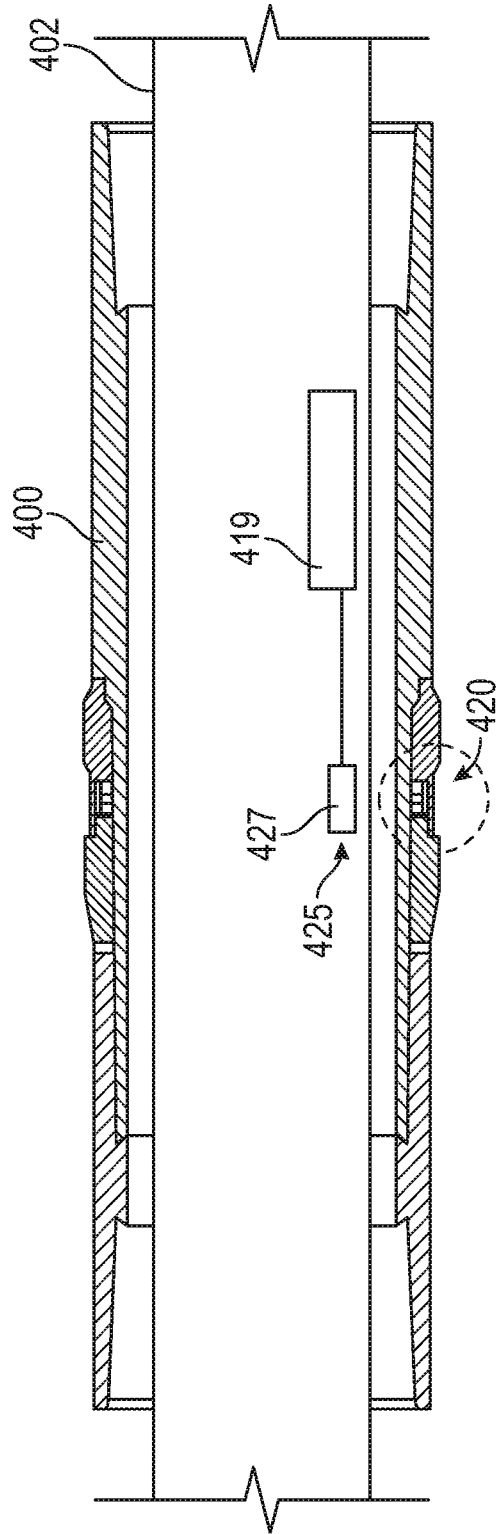

FIG. 7A

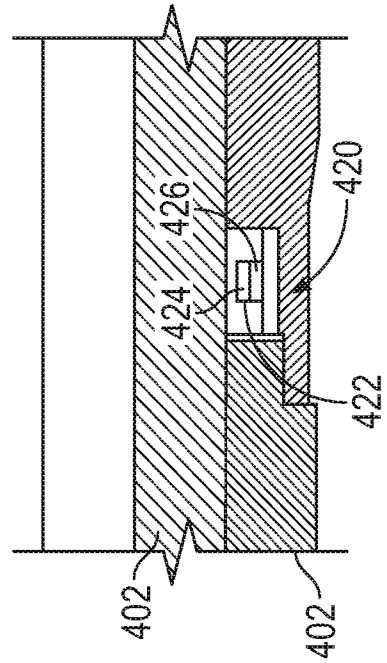

FIG. 7B

**A. CLASSIFICATION OF SUBJECT MATTER****E21B 23/01(2006.01)i, E21B 17/02(2006.01)i**

According to International Patent Classification (IPC) or to both national classification and IPC

**B. FIELDS SEARCHED**

Minimum documentation searched (classification system followed by classification symbols)

E21B 23/01; E21B 23/02; E21B 33/128; E21B 7/08; E21B 33/13; E21B 7/06; E21B 23/12; E21B 17/02

Documentation searched other than minimum documentation to the extent that such documents are included in the fields searched

Korean utility models and applications for utility models

Japanese utility models and applications for utility models

Electronic data base consulted during the international search (name of data base and, where practicable, search terms used)

eKOMPASS(KIPO internal) &amp; keywords: anchor, profile, ramp section, alignment, tangent, contour, shoulder

**C. DOCUMENTS CONSIDERED TO BE RELEVANT**

Category*	Citation of document, with indication, where appropriate, of the relevant passages	Relevant to claim No.
X	US 8789580 B2 (DANCER et al.) 29 July 2014 See column 5, lines 5-13, column 6, lines 23-53 and figures 5-12.	1-9, 11-14
Y		10, 15
Y	US 6202746 B1 (VANDENBERG et al.) 20 March 2001 See column 10, lines 58-63 and figures 1, 5a-5d.	10, 15
A	US 9316074 B2 (BAKER HUGHES INCORPORATED) 19 April 2016 See column 4, lines 15-55 and figures 2-11.	1-15
A	US 2014-0332239 A1 (FREUDENBERG OIL & GAS, LLC) 13 November 2014 See paragraphs [0027]-[0031] and figures 1a-1b.	1-15
A	US 5129453 A (GREENLEE, DONALD R.) 14 July 1992 See column 7, lines 24-48 and figure 5.	1-15

 Further documents are listed in the continuation of Box C. See patent family annex.

\* Special categories of cited documents:

"A" document defining the general state of the art which is not considered to be of particular relevance

"E" earlier application or patent but published on or after the international filing date

"L" document which may throw doubts on priority claim(s) or which is cited to establish the publication date of another citation or other special reason (as specified)

"O" document referring to an oral disclosure, use, exhibition or other means

"P" document published prior to the international filing date but later than the priority date claimed

"T" later document published after the international filing date or priority date and not in conflict with the application but cited to understand the principle or theory underlying the invention

"X" document of particular relevance; the claimed invention cannot be considered novel or cannot be considered to involve an inventive step when the document is taken alone

"Y" document of particular relevance; the claimed invention cannot be considered to involve an inventive step when the document is combined with one or more other such documents, such combination being obvious to a person skilled in the art

"&amp;" document member of the same patent family

Date of the actual completion of the international search

18 September 2018 (18.09.2018)

Date of mailing of the international search report

**18 September 2018 (18.09.2018)**

Name and mailing address of the ISA/KR

International Application Division

Korean Intellectual Property Office

189 Cheongsa-ro, Seo-gu, Daejeon, 35208, Republic of Korea

Facsimile No. +82-42-481-8578

Authorized officer

LEE, Dal Kyong

Telephone No. +82-42-481-8440



**INTERNATIONAL SEARCH REPORT**

Information on patent family members

International application No.

**PCT/US2018/034426**

Patent document cited in search report	Publication date	Patent family member(s)	Publication date
US 8789580 B2	29/07/2014	AU 2012-379122 A1	18/09/2014
		AU 2012-379122 B2	25/02/2016
		AU 2016-201336 A1	17/03/2016
		AU 2016-201336 B2	20/07/2017
		CA 2866833 A1	07/11/2013
		CA 2866833 C	25/04/2017
		CA 2960257 A1	07/11/2013
		EA 026087 B1	28/02/2017
		EA 201491515 A1	30/04/2015
		EP 2809866 A1	10/12/2014
		MX 2014011013 A	13/10/2014
		MX 347149 B	17/04/2017
		MY 164792 A	30/01/2018
		US 2013-0284458 A1	31/10/2013
		US 2014-0008130 A1	09/01/2014
		US 9238949 B2	19/01/2016
		WO 2013-165342 A1	07/11/2013
US 6202746 B1	20/03/2001	CA 2248287 A1	22/03/2000
		CA 2248287 C	21/05/2002
US 9316074 B2	19/04/2016	US 2014-0144619 A1	29/05/2014
		WO 2014-085014 A1	05/06/2014
US 2014-0332239 A1	13/11/2014	CA 2911685 A1	13/11/2014
		EP 2994605 A1	16/03/2016
		US 9518441 B2	13/12/2016
		WO 2014-182381 A1	13/11/2014
US 5129453 A	14/07/1992	None	