



(11) **EP 2 134 201 B1**

(12) **EUROPEAN PATENT SPECIFICATION**

(45) Date of publication and mention of the grant of the patent:  
**09.02.2011 Bulletin 2011/06**

(21) Application number: **08762968.9**

(22) Date of filing: **20.03.2008**

(51) Int Cl.:  
**A24D 3/04 (2006.01)**

(86) International application number:  
**PCT/IB2008/001661**

(87) International publication number:  
**WO 2008/114153 (25.09.2008 Gazette 2008/39)**

(54) **MULTI-COMPONENT FILTER PROVIDING IMPROVED FLAVOUR ENHANCEMENT**  
MEHRKOMPONENTENFILTER FÜR MEHRFACHE GESCHMACKSINTENSIVIERUNG  
FILTRE MULTI-COMPOSANT FOURNISSANT UNE AMÉLIORATION DE LA SAVEUR

(84) Designated Contracting States:  
**AT BE BG CH CY CZ DE DK EE ES FI FR GB GR HR HU IE IS IT LI LT LU LV MC MT NL NO PL PT RO SE SI SK TR**  
Designated Extension States:  
**RS**

(30) Priority: **21.03.2007 EP 07251210**

(43) Date of publication of application:  
**23.12.2009 Bulletin 2009/52**

(73) Proprietor: **Philip Morris Products S.A.**  
**2000 Neuchâtel (CH)**

(72) Inventors:  
• **BESSO, Clément**  
**2000 Neuchâtel (CH)**

- **JORDIL, Yves**  
**74500 Lugrin (FR)**
- **KUERSTEINER, Charles**  
**1008 Jouxens-Mezery (CH)**
- **WYSS-PETERS, Anne**  
**47800 Petaling Jaya (MY)**

(74) Representative: **Millburn, Julie Elizabeth**  
**Reddie & Grose**  
**16 Theobalds Road**  
**London**  
**WC1X 8PL (GB)**

(56) References cited:  
**EP-A- 1 252 832 WO-A-02/069745**  
**WO-A-03/059096 WO-A-2006/082525**  
**CH-A5- 635 232 US-A- 4 281 671**

**EP 2 134 201 B1**

Note: Within nine months of the publication of the mention of the grant of the European patent in the European Patent Bulletin, any person may give notice to the European Patent Office of opposition to that patent, in accordance with the Implementing Regulations. Notice of opposition shall not be deemed to have been filed until the opposition fee has been paid. (Art. 99(1) European Patent Convention).

**Description**

**[0001]** The present invention relates to a multi-component filter for a smoking article and to a smoking article comprising such a multi-component filter.

**[0002]** Filter cigarettes typically comprise a rod of tobacco cut filler surrounded by a paper wrapper and a cylindrical filter aligned in an end-to-end relationship with the wrapped tobacco rod and attached thereto by tipping paper.

**[0003]** In conventional filter cigarettes, the filter usually consists of a plug of cellulose acetate tow wrapped in porous plug wrap. However, filter cigarettes with multi-component filters that comprise two or more segments of filtration material for the removal of particulate and gaseous components of the mainstream smoke are also known. To enhance the flavour of the mainstream smoke produced during combustion of the wrapped tobacco rod, it is also known to provide filter cigarettes with filters that include flavourants.

**[0004]** WO-A-03/059096 discloses a cigarette with a multi-component filter comprising a bed of flavoured spherical beaded activated carbon and a flavor-releasing segment including a yarn with flavorant thereon downstream from the flavored spherical beaded activated carbon. As beaded activated carbon is an adsorbent, flavor is not released from the flavored beaded activated carbon into mainstream smoke drawn through the multi-component filter even when saturated.

**[0005]** It would be desirable to provide a multi-component filter for a smoking article such as a cigarette that provides improved flavour enhancement to mainstream smoke as it is drawn from a rod of smokable material through the filter.

**[0006]** According to the present invention there is provided a multi-component filter for a smoking article comprising: a first flavour-releasing segment proximate a mouth end of the filter; and a second flavour-releasing segment located immediately upstream of the first flavour-releasing segment, wherein the first flavour-releasing segment comprises at least one flavour-bearing thread and the second flavour-releasing segment comprises flavour-bearing cellulosic particles.

**[0007]** According to the present invention there is also provided a smoking article comprising: a rod of smokable material; and a multi-component filter, the multi-component filter comprising: a first flavour-releasing segment proximate a mouth end of the filter; and a second flavour-releasing segment located immediately upstream of the first flavour-releasing segment, wherein the first flavour-releasing segment comprises at least one flavour-bearing thread and the second flavour-releasing segment comprises flavour-bearing cellulosic particles.

**[0008]** In alternative embodiments of the multi-component filter and smoking article of the present invention, the second flavour-releasing segment comprises flavour-bearing particles made from tobacco plant material.

**[0009]** Throughout the specification, "upstream" and "downstream" are used to describe the relative positions of segments of the multi-component filter of the invention in relation to the direction of mainstream smoke drawn from a rod of smokable material through the multi-component filter during use.

**[0010]** As mainstream smoke is drawn from a rod of smokable material through the multi-component filter, flavour is released into the mainstream smoke from the flavour-bearing cellulosic particles as the smoke passes through the second flavour-releasing segment. Thereafter, additional flavour is released into the mainstream smoke from the one or more flavour-bearing threads as the smoke passes through the first flavour-releasing segment. The two adjacent flavour-releasing segments of multi-component filters according to the invention thereby advantageously maximise flavour release into the mouth of a consumer.

**[0011]** The cellulosic particles of the second flavour-releasing segment of the multi-component filter of the present invention act as flavour containers, not as adsorbents. When mainstream smoke drawn through the multi-component filter contacts the surface of the cellulosic particles, the flavour contained therein is released into the mainstream smoke.

**[0012]** According to fluid dynamics, most of the mainstream smoke from the rod of smokable material passes through the centre of the filter. The mass flow of the mainstream smoke decreases radially from the centre. By arranging a flavour carrier in the form of one or more flavour-bearing threads, for example one to five flavour-bearing threads, along the centre of the filter or distributed around the centre of the filter, flavour release into the mainstream smoke is advantageously increased.

**[0013]** In use, the one or more flavour-bearing threads of the first flavour-releasing segment act as a first flavour reservoir, while the cellulosic particles of the second flavour-releasing segment act as a second flavour reservoir. Multi-component filters according to the present invention thereby advantageously provide dual flavour enhancement to mainstream smoke drawn there through. Preferably, the amount of flavourant in the first flavour-releasing segment exceeds the amount of flavourant in the second flavour-releasing segment.

**[0014]** Multi-component filters according to the present invention may be particularly advantageously employed as filters for low tar and ultra low tar filter cigarettes. Throughout the specification, "low tar" is used to describe cigarettes having a total nicotine free dry particulate matter or "tar" delivery of between about 4 mg and about 6 mg and "ultra low tar" is used to describe cigarettes having a total tar delivery of about 3 mg or less.

**[0015]** It will be appreciated, however, that multi-component filters according to the invention may also be used as filters for filter cigarettes and other smoking articles having a higher total tar delivery, for example a total tar delivery of about 6 mg or higher.

**[0016]** The first flavour-releasing segment and the second flavour-releasing segment of multi-component filters ac-

ording to the invention may include any volatile flavourant capable of releasing flavour into mainstream smoke drawn through the multi-component filter.

**[0017]** The first flavour-releasing segment and the second flavour-releasing segment may comprise one or more natural flavourants, one or more synthetic flavourants or a combination of one or more natural flavourants and one or more synthetic flavourants.

**[0018]** For example, the first flavour-releasing segment and the second flavour-releasing segment may comprise one or more essential oils, oleoresins, absolutes, fruit concentrates, fruit extracts and distillates or combinations thereof.

**[0019]** The first flavour-releasing and the second flavour-releasing segment of multi-component filters according to the present invention may comprise flavourants including one or more flavour ingredients to create a certain flavour type. Flavourants and flavour types that may be included in the first flavour-releasing segment and the second flavour-releasing segment of multi-component filters according to the invention include, but are not limited to, coffee, tea, spices (such as cinnamon, clove and ginger), cocoa, vanilla, spearmint, peppermint, fruit flavourants (such as blueberry, cranberry, orange, peach, and strawberry), chocolate, menthol, eucalyptus, geranium extract, linalool and citrus.

**[0020]** The first flavour-releasing segment and the second flavour-releasing segment of multi-component filters according to the invention may be constructed and arranged to release the same or different flavours into mainstream smoke drawn from a rod of smokable material through the multi-component filter. In a preferred embodiment of the invention, the first flavour-releasing segment and the second flavour-releasing segment are constructed and arranged to release the same flavour into mainstream smoke drawn from a rod of smokable material through the multi-component filter.

**[0021]** In a particularly preferred embodiment of the invention, the first flavour-releasing segment and the second flavour-releasing segment are constructed and arranged to release menthol into mainstream smoke drawn from a rod of smokable material through the multi-component filter.

**[0022]** Preferably, the first flavour-releasing segment comprises a cylindrical plug of filtration material having one or more flavour-bearing threads extending substantially axially there through. More preferably, the first flavour-releasing segment comprises a cylindrical plug of cellulose acetate tow having one or more flavour-bearing threads, for example between one and five flavour-bearing threads, extending substantially axially there through. Most preferably, the first flavour-releasing segment comprises a cylindrical plug of cellulose acetate tow having a single, substantially central, flavour-bearing thread extending substantially axially there through.

**[0023]** Preferably, the first flavour-releasing segment comprises one or more flavour-bearing threads loaded with menthol.

**[0024]** The one or more threads may be formed from any suitable materials capable of bearing a flavourant including, but not limited to, cotton, cellulose acetate, rayon, or other hydrophilic textile or non-textile materials or combinations thereof. Preferably the one or more threads are formed of cotton yarn or cellulose acetate yarn.

**[0025]** Preferably, each of the one or more threads has a diameter of between about 0.6 mm and about 2.0 mm, more preferably of about 0.8 mm.

**[0026]** Filter plugs comprising flavour-bearing threads suitable for use in multi-component filters according to the present invention, and methods and apparatus for forming such plugs, are described in US-A-4,281,671 and US-A-7,074,170 and are available from the American Filtrona Company, Richmond, Virginia, USA.

**[0027]** Preferably, the first flavour-releasing segment comprises a plug of filtration material including a single flavour-bearing thread. The first flavour-releasing segment may, however, comprise a plug of filtration material including more than one flavour-bearing thread, for example up to five flavour-bearing threads. Each thread may be loaded with more than one flavourant. In addition, where the first flavour-releasing segment comprises a plug of filtration material including two or more flavour-bearing threads, the threads may be loaded with the same or different flavourants.

**[0028]** In a particularly preferred embodiment, the first flavour-releasing segment comprises a plug of cellulose acetate tow including a single, substantially central, substantially axial flavour-bearing thread loaded with menthol.

**[0029]** Preferably, the first flavour-releasing segment comprises one or more coloured flavour-bearing threads. The colour of the one or more flavour-bearing threads may be advantageously used to indicate to a consumer the flavour released by the first-flavour releasing segment into mainstream smoke drawn through the multi-component filter during use. For example, where the first flavour-releasing segment comprises one or more flavour-bearing threads loaded with menthol, the flavour bearing threads are preferably green.

**[0030]** In preferred embodiments of the invention, the first flavour-releasing segment is located at the mouth end of the multi-component filter. If desired, multi-component filters according to the invention may, however, further comprise a mouth end segment comprising a plug of filtration material or a recess downstream of the first flavour-releasing segment.

**[0031]** Where the first flavour-releasing segment is located at the mouth end of the multi-component filter, one end of the at least one flavour-bearing thread is preferably visible at the mouth end of the first flavour-releasing segment and multi-component filter.

**[0032]** The second flavour-releasing segment may comprise a plug of filtration material loaded with flavour-bearing cellulosic particles. For example, the second flavour-releasing segment may comprise a cylindrical plug of cellulose

acetate tow loaded with flavour-bearing cellulosic particles.

[0033] Alternatively, the second flavour-releasing segment may comprise a bed of flavour-bearing cellulosic particles disposed in a cavity in the multi-component filter.

[0034] Multi-component filters according to the invention may comprise second flavour-releasing segments including flavour-bearing cellulosic particles having, for example, different diameters or different colours.

[0035] Preferably, the second flavour-releasing segment comprises flavour-bearing cellulosic beads, more preferably flavour-bearing porous cellulosic beads.

[0036] Preferably, the cellulosic beads are substantially spherical.

[0037] Preferably, the cellulosic beads have a diameter of between about 0.2 mm and about 2.0 mm.

[0038] The cellulosic particles may comprise cellulose bonded with, for example, a binder such as a poly vinyl acetate binder.

[0039] A method of manufacturing cellulosic beads suitable for use in the second flavour-releasing segment of multi-component filters according to the present invention is described in EP-A-0 850 979. Cellulosic beads suitable for use in the second flavour-releasing segment of multi-component filters according to the invention are available under the brand name Viscopearl® from Rengo Co., Ltd., Japan.

[0040] Preferably, the flavour-bearing cellulosic particles are loaded with menthol.

[0041] Preferably, the external diameter of multi-component filters according to the invention is between about 5 mm and about 8.5 mm, more preferably about 7.9 mm.

[0042] Preferably, the overall length of multi-component filters according to the invention is between about 18 mm and about 36 mm, more preferably about 27 mm.

[0043] Preferably, the length of the first flavour-releasing segment is between about 9 mm and about 18 mm, more preferably about 15 mm.

[0044] Preferably, the length of the second flavour-releasing segment is between about 9 mm and about 18 mm, more preferably about 12 mm.

[0045] Multi-component filters according to the invention may further comprise a rod end segment comprising a plug of filtration material upstream of the second flavour-releasing segment.

[0046] The rod end segment may comprise any suitable fibrous or webbed filtration materials including, but not limited to, cellulose acetate tow and crepe paper.

[0047] The rod end segment may further comprise a central hollow tube extending substantially axially through the plug of filtration material. Preferably, the tube has an internal diameter of between about 0.8 mm and about 2.0 mm, more preferably of about 1.1 mm, and an external diameter of between about 1.0 mm and about 2.2 mm, more preferably of about 1.3 mm.

[0048] The inclusion of a rod end segment comprising a plug of filtration material is particularly preferred in multi-component filters according to the invention for use in low or ultra low tar filter cigarettes.

[0049] Preferably, the length of the rod end segment is between about 8 mm and about 12 mm, more preferably about 10 mm.

[0050] Preferably, multi-component filters according to the invention comprise a maximum of three segments.

[0051] Multi-component filters according to the invention may be produced by forming separate continuous rods comprising multiple units of each segment of the filter and then combining these separate rods in a known manner in one or more stages to form a continuous filter rod comprising multiple units of the multiple-component filter. The continuous filter rod may then be subsequently severed at regular intervals by a cutting mechanism to yield a succession of discrete multi-component filters according to the invention.

[0052] According to the invention there is also provided a smoking article comprising a rod of smokable material and a multi-component filter according to the invention

[0053] The multi-component filter may be attached to the wrapped rod of smokable material by tipping paper in a conventional manner. Preferably, the tipping paper has a transparent portion aligned, with the second flavour-releasing segment of the multi-component filter, such that at least some of the flavour-bearing cellulosic particles of the second flavour-releasing segment are visible through the transparent portion of the tipping paper. The use of tipping paper having at least a transparent portion in alignment with the second flavour-releasing segment is particularly preferred where the second flavour-releasing segment of the multi-component filter comprises coloured flavour-bearing cellulosic particles. The multi-component filter may be attached to the wrapped rod of smokable material by transparent tipping paper that is rendered opaque by, for example, gravure printing outside of the region that is aligned or in registration with the second flavour-releasing segment.

[0054] Preferably, the overall length of the smoking article is between about 68 mm and about 128 mm, more preferably about 84 mm.

[0055] Smoking articles according to the present invention preferably further comprise at least one circumferential row of perforations at a location along the multi-component filter in order to ventilate mainstream smoke drawn through the multi-component filter from the rod of smokable material.

**[0056]** Preferably, at least one circumferential row of perforations is located at least 12 mm from the mouth end of the multi-component filter.

**[0057]** Preferably, smoking articles according to the present invention have a total nicotine free dry particulate matter or "tar" delivery of between about 1 mg and about 6 mg, more preferably a total tar delivery of between about 1 mg and about 3 mg.

**[0058]** Preferably, the smokable material is tobacco cut filler.

**[0059]** Preferably, the rod of smokable material is wrapped in cigarette paper.

**[0060]** To maintain the flavour enhancing capabilities of multi-component filters according to the invention, smoking articles according to the invention may be packaged in, for example, soft packs, hinge lid packs or other packs that include a flavour-bearing inner liner. For example, smoking articles according to the invention comprising a multi-component filter with a second flavour-releasing segment comprising flavour-bearing cellulosic particles loaded with menthol and a first flavour-releasing segment comprising one or more flavour-bearing threads loaded with menthol may be packaged in containers with a mentholated inner liner.

**[0061]** The invention will be further described, by way of example only, with reference to the accompanying drawings in which:

Figure 1 shows a side view of a filter cigarette comprising a tobacco rod and a multi-component filter according to a first embodiment of the invention with portions thereof broken away to illustrate interior details of the multi-component filter;

Figure 2 shows a side view of a filter cigarette comprising a tobacco rod and a multi-component filter according to a second embodiment of the invention with portions thereof broken away to illustrate interior details of the multi-component filter;

Figure 3 shows a side view of a filter cigarette comprising a tobacco rod and a multi-component filter according to a third embodiment of the invention with portions thereof broken away to illustrate interior details of the multi-component filter; and

Figure 4 shows a side view of a filter cigarette comprising a tobacco rod and a multi-component filter according to a fourth embodiment of the invention with portions thereof broken away to illustrate interior details of the multi-component filter.

**[0062]** The cigarettes according to the first, second, third and fourth embodiments of the invention shown in Figures 1, 2, 3 and 4, respectively, have several components in common; these components have been given the same reference numerals throughout.

**[0063]** Each cigarette generally comprises an elongate, cylindrical wrapped rod of smokable material 2, such as tobacco cut filler, attached at one end to an axially aligned, elongate, cylindrical, multi-component filter 4. The wrapped tobacco rod 2 and the multi-component filter 4 are joined in a conventional manner by tipping paper 6, which circumscribes the entire length of the multi-component filter and an adjacent portion of the wrapped tobacco rod 2. To ventilate mainstream smoke produced during combustion of the wrapped tobacco rod 4 with ambient air, a plurality of annular perforations 8 are provided through the tipping paper 6 at a location along the multi-component filter 4.

**[0064]** The multi-component filter 4 of the cigarette 10 according to the first embodiment of the invention shown in Figure 1 includes two segments in abutting end-to-end relationship: a first flavour-releasing segment 12, located at the mouth end of the multi-component filter 4, distant from the wrapped tobacco rod 2; and a second flavour-releasing segment 14, located upstream of the first flavour-releasing segment 14, which is adjacent to and abuts the wrapped tobacco rod 2.

**[0065]** The first flavour-releasing segment 12 comprises a plug of cellulose acetate tow of medium to high filtration efficiency. A single, central flavour-bearing cotton thread 16 extends axially through the plug of cellulose acetate tow parallel to the longitudinal axis of the cigarette 10.

**[0066]** The second flavour-releasing segment 14 comprises a plug of cellulose acetate tow of high filtration efficiency, which is substantially evenly loaded with a plurality of flavour-bearing cellulosic beads 18. The tipping paper 6 may be transparent at least where it circumscribes the second flavour-releasing segment 14, such that the flavour-bearing cellulosic beads 18 of the second flavour-releasing segment 14 are visible through the tipping paper 6.

**[0067]** In use, mainstream smoke is drawn downstream from the lit end of the wrapped tobacco rod 2 through the multi-component filter 4. As the mainstream smoke enters the multi-component filter 4 it passes through the second flavour-releasing segment 14, where the high filtration efficiency cellulose acetate tow partially filters out particulate phase components of the smoke and flavour is released into the mainstream smoke from the flavour-bearing cellulosic beads 18.

**[0068]** Having passed through the second flavour-releasing segment 14, the mainstream smoke enters the first flavour-releasing segment 12 at the mouth end of the multi-component filter 4, where the medium to high filtration efficiency cellulose acetate tow also partially filters out particulate phase components of the smoke and further flavour is released

into the smoke from the flavour-bearing cotton thread 16.

**[0069]** The dual flavour-enhanced smoke then exits the first flavour-releasing segment 12 of the multi-component filter 4 through the mouth end of the cigarette 10.

**[0070]** The high filtration efficiency of the cellulose acetate tow in the second flavour-releasing segment 14 maximises filtration of particulate phase components of the mainstream smoke. At the same time, the first flavour-releasing segment 12 and the second flavour-releasing segment 14 of the multi-component filter 4 advantageously provide dual flavour enhancement to the mainstream smoke. A particularly preferred cigarette according to the first embodiment of the invention, in which the flavour bearing cellulosic beads 18 of the second flavour-releasing segment 14 and the flavour-bearing thread 16 of the first flavour-releasing segment 12 are highly loaded with menthol, has a nicotine delivery of 0.1 mg and a tar delivery of 1 mg, including in the tar delivery a menthol delivery of 0.3 mg.

**[0071]** The cigarette 20 according to the second embodiment of the invention shown in Figure 2 has a multi-component filter 4 that includes three segments in abutting end-to-end relationship: a first flavour-releasing segment 12, located at the mouth end of the multi-component filter 4 distant from the wrapped tobacco rod 2; a second flavour-releasing segment 14, located upstream of the first flavour-releasing segment 12; and a rod end segment 22 located upstream of the second flavour-releasing segment 12, which is adjacent to and abuts the wrapped tobacco rod 2.

**[0072]** The first flavour-releasing segment 12 is of the same construction as the first flavour-releasing segment 12 of the cigarette 10 shown in Figure 1, but comprises a plug of cellulose acetate tow of medium to low filtration efficiency.

**[0073]** The second flavour-releasing segment 14 is also of the same construction as the second flavour-releasing segment 14 of the cigarette 10 shown in Figure 1, but comprises a plug of cellulose acetate tow of low to medium, filtration efficiency.

**[0074]** The rod end segment 22 comprises a plug of cellulose acetate tow of high filtration efficiency.

**[0075]** The cigarette 24 according to the third embodiment of the invention shown in Figure 3 also has a multi-component filter that includes three segments in abutting end-to-end relationship: a first flavour-releasing segment 12, located at the mouth end of the multi-component filter 4 distant from the wrapped tobacco rod 2; a second flavour-releasing segment 14, located upstream of the first flavour-releasing segment 12; and a rod end segment 22 located upstream of the second flavour-releasing segment 12, which is adjacent to and abuts the wrapped tobacco rod 2.

**[0076]** The rod end segment 22 is of the same construction as the rod end segment 22 of the cigarette 20 shown in Figure 2.

**[0077]** The first flavour-releasing segment 12 is also of the same construction as the first flavour-releasing segment 12 of the cigarette 20 shown in Figure 2, but comprises a plug of cellulose acetate tow of low to medium filtration efficiency.

**[0078]** The second flavour-releasing segment 14 is a cavity located between the rod end segment 22 and the first flavour-releasing segment 12, which is filled with flavour-bearing cellulosic beads.

**[0079]** In a particularly preferred cigarette according to the third embodiment of the invention the flavour bearing cellulosic beads 18 of the second flavour-releasing segment 14 and the flavour-bearing thread 16 of the first flavour-releasing segment 12 are highly loaded with menthol and the cavity of the second flavour-releasing segment 14 is filled to a volume of about 80% or more with the flavour-bearing cellulosic beads.

**[0080]** The cigarette 26 according to the fourth embodiment of the invention shown in Figure 4 also has a multi-component filter that includes three segments in abutting end-to-end relationship: a first flavour-releasing segment 12, located at the mouth end of the multi-component filter 4 distant from the wrapped tobacco rod 2; a second flavour-releasing segment 14, located upstream of the first flavour-releasing segment 12, and a rod end segment 22 located upstream of the second flavour-releasing segment 12, which is adjacent to and abuts the wrapped tobacco rod 2.

**[0081]** The first flavour-releasing segment 12 is of the same construction as the first flavour-releasing segment 12 of the cigarette 20 shown in Figure 2, but comprises a plug of cellulose acetate tow of low to medium filtration efficiency.

**[0082]** The second flavour-releasing segment 14 is also of the same construction as the second flavour-releasing segment 14 of the cigarette 20 shown in Figure 2, but comprises a plug of cellulose acetate tow of low to high filtration efficiency, depending on the desired overall filtration effect of the cigarette 26.

**[0083]** As shown in Figure 4, the rod end segment 22 comprises a plug of cellulose acetate tow of medium to high filtration efficiency and a central hollow tube 28, which extends axially through the plug of cellulose acetate tow parallel to the longitudinal axis of the cigarette 26. The central hollow tube 28 extending axially through the rod end segment 22, which maximises filtration of particulate phase components of the mainstream smoke, increases the tar delivery of the first few puffs of mainstream smoke drawn through the cigarette 26.

**[0084]** To form the cigarettes 10, 20, 24, 26 according to the first, second, third and fourth embodiments of the inventions shown in Figures 1, 2, 3 and 4, respectively, the multi-component filters 4 are produced and then joined to the wrapped tobacco rods 2, which are produced in a conventional manner, by tipping paper 6 using known filter cigarette making equipment.

**[0085]** To produce the multi-component filters 4 of the cigarettes 10, 20, 26 according to the first, second and fourth embodiments of the invention, separate continuous rods comprising multiple units of each segment 12, 14, 22 of the multi-component filter 4 are produced in a known manner and then combined to form a continuous filter rod comprising

## EP 2 134 201 B1

multiple units of the multiple-component filter 4. The continuous filter rod is then severed at regular intervals by a cutting mechanism to yield a succession of discrete multi-component filters 4.

[0086] To produce the multi-component filter 4 of the cigarette 24 according to the third embodiment of the invention, separate continuous rods comprising multiple units of the first flavour-releasing segment 12 and the rod end segment 22 of the multi-component filter 4 are produced in a known manner and then combined to form a continuous filter rod comprising multiple first flavour-releasing segments 12 and multiple rod end segments 22 separated by cavities. The cavities are filled with cellulosic beads 18 to form multiple second flavour-releasing segments 14 and the continuous filter rod comprising multiple units of the multiple-component filter 4 is then severed at regular intervals by a cutting mechanism to yield a succession of discrete multi-component filters 4.

### Example

[0087] A filter cigarette according to the first embodiment of the invention having the dimensions and properties given in Table 1 below is produced by a conventional combining process.

**Table 1**

	<b>Cigarette</b>		
Resistance to draw (mm WG)	88		
Length (mm)	84.0		
Circumference (mm)	24.8		
Nicotine Free Dry Particulate Matter (mg)	1		
Nicotine (mg)	0.1		
	<b>Multi-component filter</b>		<b>Tobacco rod</b>
Resistance to draw (mm WG)	165		-
Ventilation (%)	75		-
Length (mm)	27.0		57.0
Menthol (mg)	11.70		-
<b>Segment:</b>	<b>First flavour-releasing segment</b>	<b>Second flavour-releasing segment</b>	-
Length (mm)	15.0	12.0	-
Resistance to draw (mm WG)	60	105	-
Cellulose acetate: denier per filament	2.5	1.5	-
Cellulose acetate: total denier	37000	46000	-
Cotton thread (mg)	6.2	-	-
Cellulosic beads (mg)	-	29.34	-
Menthol (mg)	10.8	0.9	-

[0088] While the invention has been exemplified above with reference to filter cigarettes comprising multi-component filters including plugs of cellulose acetate tow, it will be appreciated that multi-component filters according to the present invention may comprise plugs of other suitable fibrous or webbed filtration material.

[0089] As described above, in use, the first flavour-releasing segment and second flavour-releasing segment of multi-component filters according to the present invention can each release desired flavours into mainstream smoke passing through the multi-component filter, thereby advantageously providing dual flavour enhancement to the mainstream smoke. Through the provision of dual flavour enhancement to mainstream smoke drawn there through, multi-component filters according to the invention advantageously enable the manufacture of filter cigarettes and other filtered smoking articles that are flavourful, whilst still achieving significant reductions in particulate phase and gas phase components of the mainstream smoke and an acceptable overall resistance to draw.

**Claims**

1. A multi-component filter (4) for a smoking article comprising:

5 a first flavour-releasing segment (12) proximate a mouth end of the filter; and  
 a second flavour-releasing segment (14) located immediately upstream of the first flavour-releasing segment (12),  
 wherein the first flavour-releasing segment (12) comprises at least one flavour-bearing thread (16) and the  
 10 second flavour-releasing segment (14) comprises flavour-bearing cellulosic particles (18).

2. A multi-component filter (4) according to claim 1 wherein the second flavour-releasing segment (14) comprises a plug of filtration material loaded with flavour-bearing cellulosic particles (18).

3. A multi-component filter (4) according to claim 1 wherein the second flavour-releasing segment (14) comprises a bed of flavour-bearing cellulosic particles (18) disposed in a cavity in the filter (4).

4. A multi-component filter (4) according to claim 1, 2 or 3 wherein the cellulosic particles (18) are porous, substantially spherical, cellulosic beads.

5. A multi-component filter (4) according to any of claims 1 to 4 wherein the first flavour-releasing segment (12) comprises a plug of filtration material and a substantially central flavour-bearing thread (16) that extends substantially axially through the plug of filtration material.

6. A multi-component filter (4) according to any preceding claim further comprising:

25 a rod end segment (22) comprising a plug of filtration material upstream of the second flavour-releasing segment (14).

7. A multi-component filter (4) according to claim 6 wherein the rod end segment (22) further comprises a substantially central hollow tube (28) that extends substantially axially through the plug of filtration material.

8. A multi-component filter (4) according to any preceding claim wherein the first flavour-releasing segment (12) is located at the mouth end of the filter (4).

9. A smoking article (10)(20)(24)(26) comprising:

a rod (2) of smokable material; and  
 a multi-component filter (4) according to any preceding claim.

10. A smoking article (10)(20)(24)(26) according to claim 9 wherein the multi-component filter (4) is attached to the rod (2) of smokable material by tipping paper (6) having a transparent portion in alignment with the second flavour-releasing segment (14) of the multi-component filter (4).

**Patentansprüche**

1. Mehrkomponentenfilter (4) für einen Raucherartikel, umfassend:

50 ein erstes Geschmackstoff freisetzendes Segment (12) nahe einem Mundende des Filters und  
 ein zweites Geschmackstoff freisetzendes Segment (14), das sich in Strömungsrichtung unmittelbar vor dem  
 ersten Geschmackstoff freisetzenden Segment (12) befindet,  
 wobei das erste Geschmackstoff freisetzende Segment (12) wenigstens einen Geschmackstoff tragenden Faden (16) umfasst und das zweite Geschmackstoff freisetzende Segment (14) Geschmackstoff tragende zellulose  
 55 losische Teilchen (18) umfasst.

2. Mehrkomponentenfilter (4) nach Anspruch 1, bei dem das zweite Geschmackstoff freisetzende Segment (14) einen mit Geschmackstoff tragenden zellulose Teilchen (18) befüllten Stab aus Filtrationsmaterial umfasst.

## EP 2 134 201 B1

3. Mehrkomponentenfilter (4) nach Anspruch 1, bei dem das zweite Geschmackstoff freisetzende Segment (14) ein Bett aus Geschmackstoff tragenden zellulosischen Teilchen (18) aufweist, das in einem Hohlraum in dem Filter (4) angeordnet ist.
- 5 4. Mehrkomponentenfilter (4) nach Anspruch 1, 2 oder 3, bei dem die zellulosischen Teilchen (18) poröse, im Wesentlichen kugelförmige zellulosische Kügelchen sind.
5. Mehrkomponentenfilter (4) nach einem der Ansprüche 1 bis 4, bei dem das erste Geschmackstoff freisetzende Segment (12) einen Stab aus Filtrationsmaterial und einen im Wesentlichen zentralen, Geschmackstoff tragenden Faden (16) umfasst, der im Wesentlichen axial durch den Stab aus Filtrationsmaterial verläuft.
- 10 6. Mehrkomponentenfilter (4) nach einem der vorhergehenden Ansprüche, ferner umfassend:  
ein Stabendsegment (22), das einen Stab aus Filtrationsmaterial in Strömungsrichtung vor dem zweiten Geschmackstoff freisetzenden Segment (14) aufweist.
- 15 7. Mehrkomponentenfilter (4) nach Anspruch 6, bei dem das Stabendsegment (22) ferner eine im Wesentlichen zentrale, hohle Röhre (28) aufweist, die im Wesentlichen axial durch den Stab aus Filtrationsmaterial verläuft.
- 20 8. Mehrkomponentenfilter (4) nach einem der vorhergehenden Ansprüche, bei dem das erste Geschmackstoff freisetzende Segment (12) sich am Mundende des Filters (4) befindet.
9. Raucherartikel (10) (20) (24) (26), umfassend:
- 25 einen Stab (2) aus rauchbarem Material und  
einen Mehrkomponentenfilter (4) nach einem der vorhergehenden Ansprüche.
10. Raucherartikel (10) (20) (24) (26) nach Anspruch 9, bei dem der Multikomponentenfilter (4) durch Belagpapier (6), das einen transparenten Abschnitt hat, der mit dem zweiten Geschmackstoff freisetzenden Segment (14) des Mehrkomponentenfilters (4) fluchtet, an dem Stab (2) aus rauchbarem Material angebracht ist.
- 30

### Revendications

- 35 1. Filtre multicomposant (4) pour un article à fumer, comprenant :
- un premier segment de dégagement d'arôme (12) à proximité d'un embout du filtre;  
et  
un deuxième segment de dégagement d'arôme (14) situé immédiatement en amont du premier segment de  
40 dégagement d'arôme (12),  
dans lequel le premier segment de dégagement d'arôme (12) comprend au moins un fil porteur d'arôme (16)  
et le deuxième segment de dégagement d'arôme (14) comprend des particules cellulosiques porteuses d'arôme  
(18).
- 45 2. Filtre multicomposant (4) selon la revendication 1, dans lequel le deuxième segment de dégagement d'arôme (14) comprend un bouchon de matière filtrante chargé de particules cellulosiques porteuses d'arôme (18).
3. Filtre multicomposant (4) selon la revendication 1, dans lequel le deuxième segment de dégagement d'arôme (14) comprend une couche de particules cellulosiques porteuses d'arôme (18) disposée dans une cavité dans le filtre (4).
- 50 4. Filtre multicomposant (4) selon la revendication 1, 2 ou 3, dans lequel les particules cellulosiques (18) sont des billes cellulosiques, poreuses, sensiblement sphériques.
5. Filtre multicomposant (4) selon l'une quelconque des revendications 1 à 4, dans lequel le premier segment de  
55 dégagement d'arôme (12) comprend un bouchon de matière filtrante et un fil porteur d'arôme sensiblement central  
(16) qui s'étend sensiblement axialement à travers le bouchon de matière filtrante.
6. Filtre multicomposant (4) selon l'une quelconque des revendications précédentes, comprenant en outre :

## EP 2 134 201 B1

un segment d'extrémité de boudin (22) comprenant un bouchon de matière filtrante en amont du deuxième segment de dégagement d'arôme (14).

5 7. Filtre multicomposant (4) selon la revendication 6, dans lequel le segment d'extrémité de boudin (22) comprend en outre un tube creux sensiblement central (28) qui s'étend sensiblement axialement à travers le bouchon de matière filtrante.

10 8. Filtre multicomposant (4) selon l'une quelconque des revendications précédentes, dans lequel le premier segment de dégagement d'arôme (12) est situé au niveau de l'embout du filtre (4).

9. Article à fumer (10)(20)(24)(26), comprenant :

un boudin (2) de matière fumable; et

15 un filtre multicomposant (4) selon l'une quelconque des revendications précédentes.

20 10. Article à fumer (10)(20)(24)(26) selon la revendication 9, dans lequel le filtre multicomposant (4) est attaché au boudin (2) de matière fumable par du papier manchette (6) ayant une portion transparente alignée avec le deuxième segment de dégagement d'arôme (14) du filtre multicomposant.

25

30

35

40

45

50

55

...

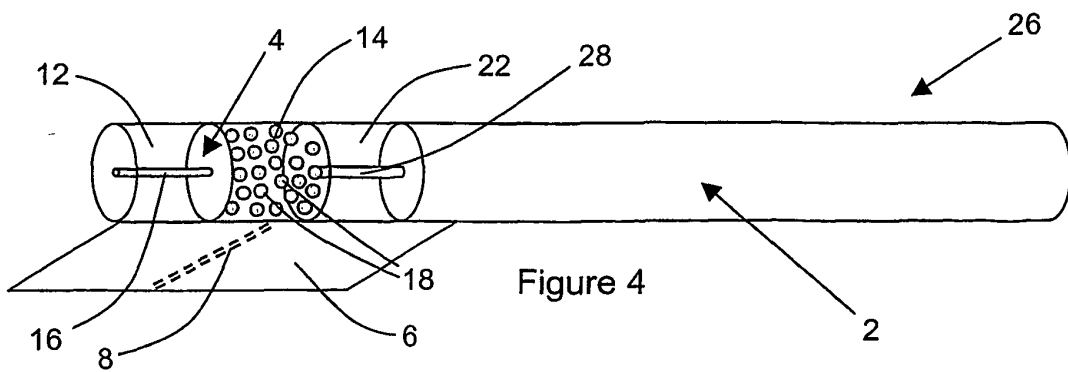
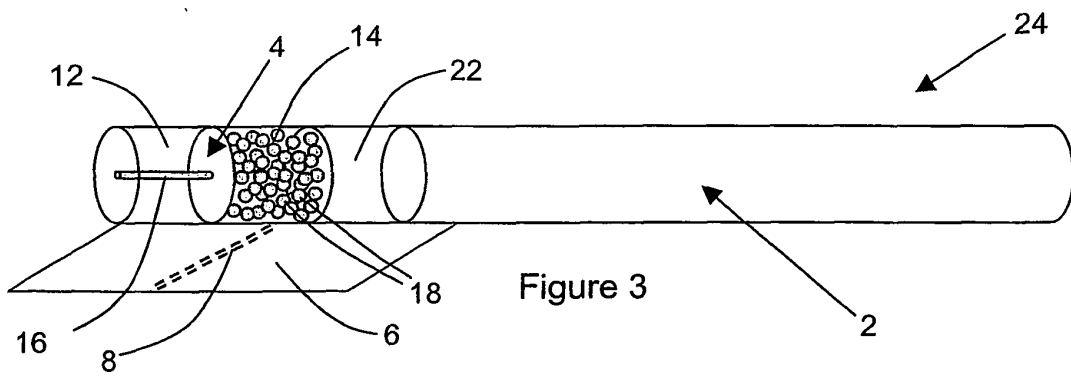
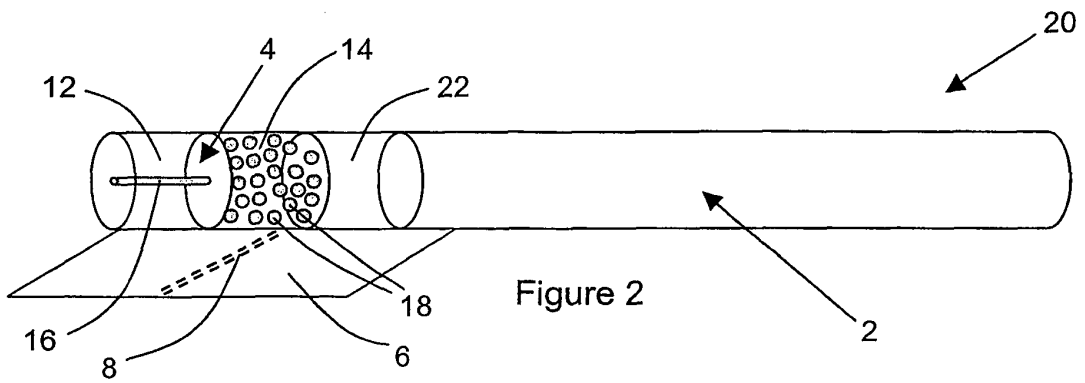
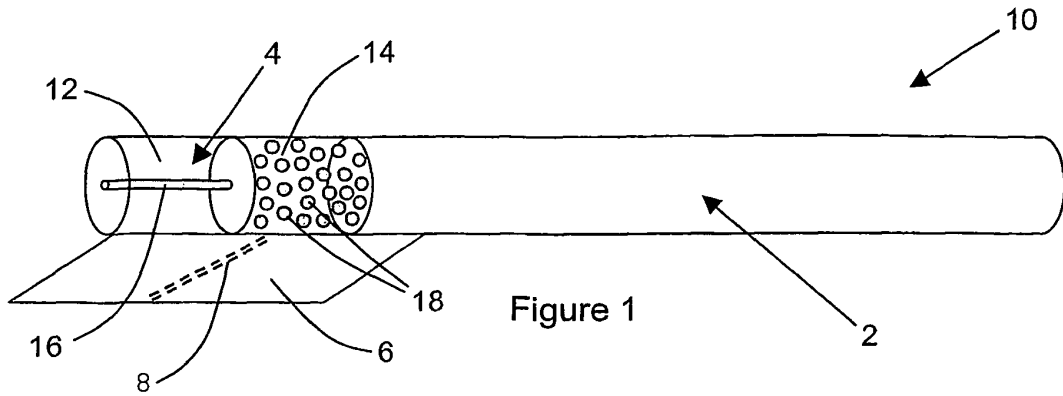

**REFERENCES CITED IN THE DESCRIPTION**

*This list of references cited by the applicant is for the reader's convenience only. It does not form part of the European patent document. Even though great care has been taken in compiling the references, errors or omissions cannot be excluded and the EPO disclaims all liability in this regard.*

**Patent documents cited in the description**

- WO 03059096 A [0004]
- US 4281671 A [0026]
- US 7074170 A [0026]
- EP 0850979 A [0039]