



(72) PANDEL, JURGEN, DE

(72) BASE, GERO, DE

(72) OERTEL, NORBERT, DE

(71) SIEMENS AKTIENGESELLSCHAFT, DE

(51) Int.Cl.⁷ G06T 9/00

(30) 1998/09/29 (198 44 664.0) DE

(54) **PROCEDE ET SYSTEME DE TRAITEMENT D'UNE IMAGE
NUMERISEE DOTEE DE POINTS D'IMAGES**

(54) **METHOD AND ARRAY FOR PROCESSING A DIGITIZED
IMAGE WITH IMAGE POINTS**

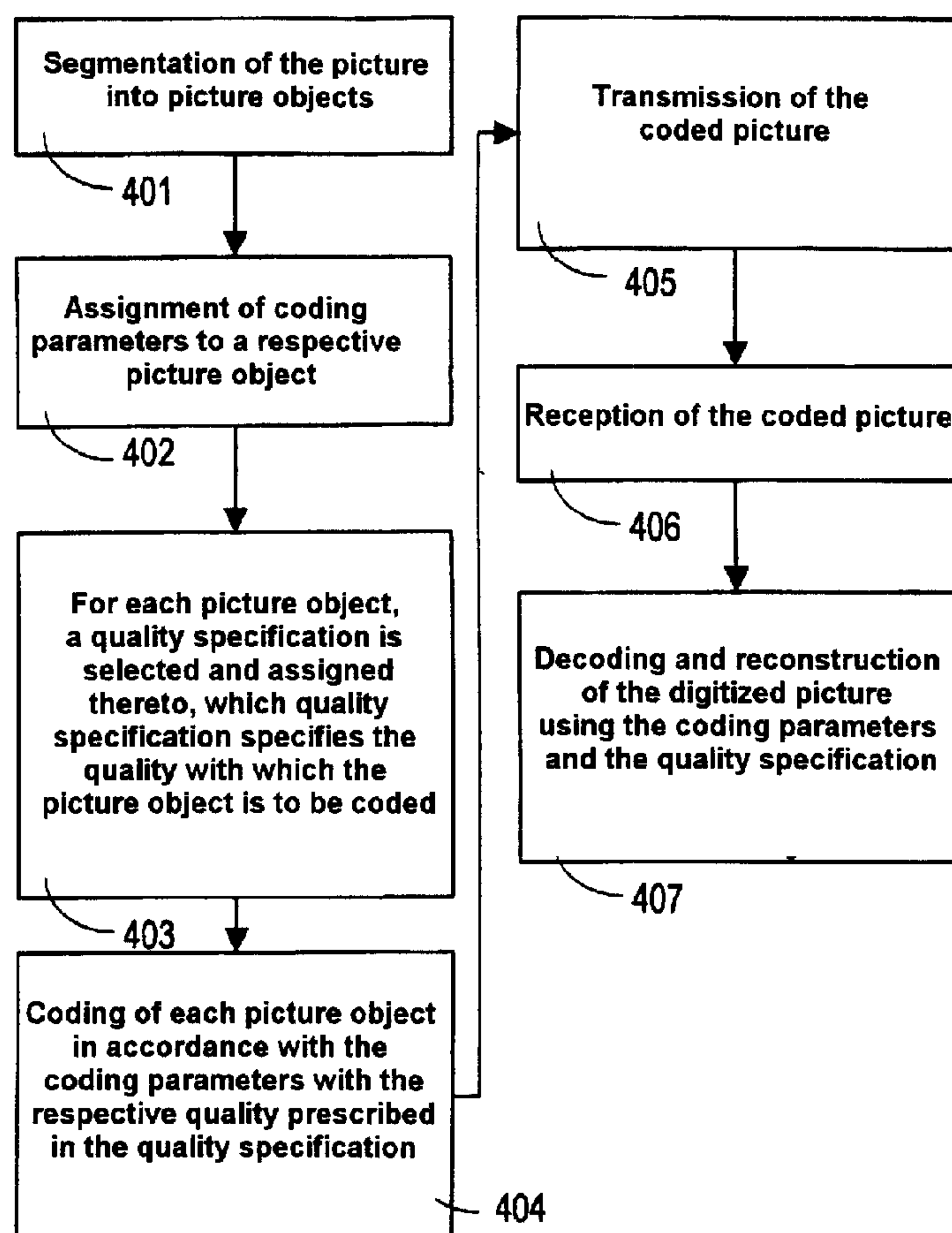

(57) Image points of the image are grouped in image blocks. The image is segmented into at least one image object and a second image object, wherein at least one image block is allocated to at least one part of an edge of the first image object. Information on the image object is allocated to the at least one image block.

(57) Abstract

Image points of the image are grouped in image blocks. The image is segmented into at least one image object and a second image object, wherein at least one image block is allocated to at least one part of an edge of the first image object. Information on the image object is allocated to the at least one image block.

GR 98 P 2749

Description**Method and arrangement for processing a digitized picture with pixels**

5

The invention relates to a method and an arrangement for processing a digitized picture with pixels.

Such an arrangement and such a method are disclosed in [1].

In the arrangement disclosed in [1] and in the method disclosed in [1], a digitized picture to be processed has pixels to which coding information is assigned in each case.

15 Coding information is to be understood hereinafter to mean brightness information (luminance value) and/or chrominance information (color value) assigned to the respective pixel.

The pixels are grouped into picture blocks, each picture block normally having $8 * 8$ or $16 * 16$ pixels.

The picture blocks are furthermore grouped into macroblocks, each macroblock having four picture blocks which contain coding information in the form of brightness information (luminance picture blocks), and two picture blocks which contain chrominance information (chrominance picture blocks).

30 In the picture coding method which is disclosed in [1] and is configured in accordance with the H.263/V.2 standard, provision is made for using so-called difference-picture coding for coding a digitized picture.

It is precisely in the case where such difference-picture coding is used that, in the case of a moving camera which records

35

a scene, or else in the case of a recorded scene which is subjected to changes, the problem arises that the recorded background is not stationary.

This problem area takes on particular
5 significance in the use of such methods for picture coding in the context of a mobile communications device, for example in the case of use in the context of a video mobile phone.

A video mobile phone is to be understood to be
10 an apparatus in which a camera for recording a sequence of pictures and a telephone are integrated in an apparatus, the telephone being a radio telephone.

In the case of customary difference-picture coding, in such a case of a greatly changing
15 background, a high proportion of an available data rate for the communication is required for coding for the greatly changing background, with the result that a smaller proportion of the available data rate remains for an object of interest which can be seen in a
20 foreground of the picture and only changes slightly compared with the background, and, accordingly, the quality of the respectively coded picture is too poor.

However, it is often desirable for an object situated in the foreground to have a good quality,
25 while a poorer quality in the picture coding with low resolution is entirely acceptable for the background.

[1] describes that, in an optional coding mode (slice structured mode), the digitized picture is subdivided into rectangles, the so-called slices, and
30 coding parameters are respectively allocated separately to each rectangle.

The coding parameters specify, inter alia, the quantization with which the object contained in the respective rectangle is to be coded.

This procedure disclosed in [1] has the disadvantage that the entire picture has to be decomposed into individual rectangles. This leads to considerable inflexibility in the context of coding a digitized picture. A further disadvantage in the case of the procedure disclosed in [1] is to be seen in the fact that only a uniform spatial resolution can be used for all the slices.

[2] discloses an object-based picture coding method referred to as an MPEG-4 picture coding method. In this method, different objects within the digitized picture are coded separately from one another. The video data streams arising from the coding of the individual picture objects are combined using a multiplexer. The method in accordance with the MPEG-4 standard has the disadvantage, in particular, that, on account of the highly complex method of coding the individual video data streams, in the case of a multiplicity of picture objects to be coded, considerable computing power is required for coding in real time and for automatic generation - resulting from the coded quantity of video data streams - of a scene description describing the interaction of the individual picture objects within the digitized picture. The requisite computing power is currently not available particularly in the case of mobile communications devices, for example a video mobile phone.

[3] discloses a method for segmenting a picture into picture objects, said method being referred to as moving object segmentation.

05-12-2000 1998P02749WO
PCT/DE 99/02763

DE 009902763

- 4 -

[4] discloses reducing block artifacts produced in the context of block-based picture coding by using a block edge filter.

[5] discloses a method for processing a digitized picture with pixels, in which the pixels are grouped into picture blocks, in which the picture is segmented into at least a first picture object and a second picture object, at least one picture block being assigned to at least a part of an edge of the first picture object and in which information about the picture object is assigned to the at least one picture block.

[5] does not disclose that the method is used in a mobile communications device. However, this feature is disclosed in [6], where a method for transmitting pictures between mobile telephones is described.

Consequently, the invention is based on the problem of specifying a method and an arrangement for processing a digitized picture with pixels, which have increased flexibility with regard to the coding of a picture and require reduced computing power compared with the known methods.

The problem is solved by means of the method and also by means of the arrangement having the features in accordance with the independent patent claims.

A method for processing a digitized picture with pixels has the following steps:

- a) the pixels are grouped into picture blocks,
- b) the picture is segmented into at least a first picture object and a second picture object, at least one picture block being assigned to at least a part of an edge of the first picture object and

AMENDED SHEET

05-12-2000 1998P02749WO
PCT/DE 99/02763

DE 009902763

- 4a -

c) information about the picture object is assigned to the at least one picture block.

An arrangement for processing a digitized picture with pixels contains a processor which is set
5 up in such a way that

- a) the pixels are grouped into picture blocks,
b) the picture is segmented into at least a first picture object and a second picture object, at least one picture block being assigned to at least
10 a part of an edge of the first picture object and
c) information about the picture object is assigned to the at least one picture block.

AMENDED SHEET

The invention achieves a simpler method of coding picture objects which enables a flexible division of the available data rate for coding different picture objects.

5 Preferred developments of the invention emerge from the dependent claims.

Preferably, a plurality of picture blocks are in each case grouped to form a macroblock. A macroblock is assigned at least to the part of the edge.

10 A further refinement provides for at least one luminance block of the macroblock to be assigned at least to the part of the edge of the first picture object.

Furthermore, at least one picture block is preferably assigned to the entire edge of the first picture object.

Furthermore, a development provides for information about the picture object to be in each case assigned to all the macroblocks in which the edge of
20 the first picture object is contained.

In a further refinement, the first picture object is addressed using a macroblock address respectively assigned to a macroblock.

A further refinement provides for the second
25 picture object to be addressed using a macroblock address respectively assigned to a macroblock.

Preferably, the picture objects are coded with different quality, in which case, preferably, a quality specification indicating the quality with which a
30 picture object is coded is assigned to at least one macroblock contained in the corresponding picture object.

The method and the apparatus can be used for coding a digitized picture or for decoding a digitized picture.

5 The apparatus and the method are suitable for use in a mobile communications device, for example a video mobile phone.

An exemplary embodiment of the invention is illustrated in the figures and is explained in more detail below.

10 In the figures:

Figure 1 shows a sketch of a picture which is processed in accordance with the exemplary embodiment;

15 Figure 2 shows an arrangement of two computers, a camera and a screen, by means of which the picture data are coded, transmitted, decoded and displayed;

Figure 3 shows a sketch of an apparatus for block-based coding of a digitized picture;

20 Figure 4 shows a flow diagram illustrating the method steps for coding, transmission and decoding of a digitized picture.

Figure 2 shows an arrangement which comprises two computers 202, 208 and a camera 201, illustrating 25 the picture coding, transmission of picture data and picture decoding.

A camera 201 is connected to a first computer 202 via a line 219. The camera 201 communicates recorded pictures 204 to the first computer 202. The 30 first computer 202 has a first processor 203, which is connected via a bus 218 to a frame store 205. A method for picture coding is carried out using the first processor 203 of the first computer 202. Picture data 206 coded

35

in this way are transmitted from the first computer 202 via a communication link 207, preferably a line or a radio link, to a second computer 208. The second computer 208 contains a second processor 209, which is
5 connected via a bus 210 to a frame store 211. A method for picture decoding is carried out using the second processor 209.

Both the first computer 202 and the second computer 208 have a respective screen 212 and 213, on
10 which the picture data 204 are displayed, with the display on the screen 212 of the first computer 202 normally being only for monitoring purposes. Input units, preferably a keyboard 214 or 215, respectively, and a computer mouse 216 or 217, respectively, are in
15 each case provided to control both the first computer 202 and the second computer 208.

The picture data 204 which are transmitted from the camera 201 via the line 219 to the first computer 202 are data in the time domain, while the data 206
20 which are transmitted from the first computer 202 to the second computer 208 via the communication link 207 are picture data in the spectral domain.

The decoded picture data are displayed on the screen 213.

25 **Figure 3** shows a sketch of an arrangement for carrying out a block-based picture coding method in accordance with the H.263 Standard (see [1]).

A video data stream to be coded and with chronologically successive digitized pictures is
30 supplied to a picture coding unit 301. The digitized pictures are subdivided into macroblocks 302, with each macroblock containing 16x16 pixels. The macroblock 302 comprises 4 picture blocks 303, 304, 305 and 306, with each picture block containing 8x8 pixels to which

luminance values (brightness values) are assigned. Furthermore, each macroblock 302 comprises two chrominance blocks 307 and 308 with chrominance values (color difference values) allocated to the pixels.

5 The picture blocks are supplied to a transformation coding unit 309. In the case of difference-picture coding, values to be coded for picture blocks in chronologically preceding pictures are removed from the picture blocks to be coded at that
10 time, and only the difference-forming information 310 is supplied to the transformation coding unit (discrete cosine transformation DCT) 309. For this purpose, the current macroblock 302 is reported via a link 334 to a motion estimation unit 329. Spectral coefficients 311
15 are formed in the transformation coding unit 309 for the picture blocks and difference picture blocks to be coded, and are supplied to a quantization unit 312.

 Quantized spectral coefficients 313 are supplied in a backward path both to a scanning unit 314
20 and to an inverse quantization unit 315. After a scanning method, for example a zigzag scanning method, entropy coding is carried out on the scanned spectral coefficients 332, in an entropy coding unit 316 provided for this purpose. The entropy-coded spectral
25 coefficients are transmitted to a decoder as coded picture data 317 via a channel, preferably a line or a radio link.

 Inverse quantization of the quantized spectral coefficients 313 is carried out in the inverse
30 quantization unit 315. Spectral coefficients 318 obtained in this way are supplied to an inverse transformation coding unit 319 (inverse discrete cosine transformation IDCT). Reconstructed coding values (also difference coding values) 320 are supplied in the
35 difference picture mode to an adder 321. The adder 321 furthermore receives coding values for a picture block, which result from a chronologically preceding picture once motion compensation

has already been carried out. The adder 321 is used to form reconstructed picture blocks 322, which are stored in a frame store 323.

Chrominance values 324 for the reconstructed
5 picture blocks 322 are supplied from the frame store 323 to a motion compensation unit 325. For brightness values 326, interpolation is carried out in an interpolation unit 327 provided for this purpose. The interpolation is preferably used to quadruple the
10 number of brightness values contained in the respective picture block. All the brightness values 328 are supplied both to the motion compensation unit 325 and to the motion estimation unit 329. The motion estimation unit 329 also receives the picture blocks of
15 the respective macroblock (16x16 pixels) to be coded, via the link 334. The motion estimation is carried out in the motion estimation unit 329, taking account of the interpolated brightness values ("motion estimation on a half-pixel basis").

20 The result of the motion estimation is a motion vector 330 which expresses a local displacement of the selected macroblock from the chronologically preceding picture to the macroblock 302 to be coded.

Both brightness information and chrominance
25 information related to the macroblock determined by the motion estimation unit 329 are shifted through the motion vector 330 and are subtracted from the coding values of the macroblock 302 (see the data path 331).

The motion estimation thus results in the
30 motion vector 330 with two motion vector components, a first motion vector component BV_x and a second motion vector component BV_y along the first direction x and the second direction y :

$$BV = \begin{pmatrix} BV_x \\ BV_y \end{pmatrix}.$$

The motion vector 330 is assigned to the picture block.

The picture coding unit shown in **Figure 3** thus
5 supplies a motion vector 330 for all the picture blocks and macro picture blocks.

Figure 1 shows a picture 100 recorded by the camera 201 and having pixels, the pixels being grouped into picture blocks 101. 8x8 pixels are in each case
10 grouped to form a picture block 101.

Luminance information is assigned to the pixels. Four luminance picture blocks 101 are grouped to form a macroblock 102.

Figure 1 shows a first picture object 104,
15 which describes a person, a second picture object 105, which describes a table surface, and a third object 103, which describes a picture background.

The first picture object 104 and the second picture object 105 together form a picture foreground.

20 In a first step (step 401, cf. **Figure 4**), the picture is segmented into a plurality of picture objects. The picture is segmented in accordance with the method described in [3], this method being referred to as moving object segmentation. The segmentation is
25 effected in such a way that an edge 106, 107 of the first picture object 104 and of the second picture object 105, respectively, in each case correspond to a block boundary of a macroblock or at least to the block boundaries of the luminance picture blocks in a
30 macroblock.

In a second step (step 402), a set of coding parameters is in each case assigned to each picture object 103, 104, 105.

5 The coding parameters specify, inter alia, the spatial resolution to be used for coding the respective picture object, motion vectors, coding type (intra-frame coding or inter-frame coding), quantization, etc.

10 Furthermore, for each picture object 103, 104, 105, in a further step (step 403), a quality specification is selected and assigned to the respective picture object 103, 104, 105 as a coding parameter. The quality specification specifies the quality with which the picture object is to be coded in each case.

15 In this example, the quality specification is given by the specification of the quantization to be chosen.

20 The coding parameters are stored in a picture object header field (object header) assigned to the respective picture object 103, 104, 105, coded and transmitted together with the remaining picture information to be coded, the picture blocks and/or the difference picture information.

25 In accordance with the above-described method illustrated in **Figure 3**, in a further step (step 404), each picture object 103, 104, 105 is coded in accordance with the coding parameters with the respective quality prescribed in the quality specification.

30 In this case, a foreground object, i.e. the first picture object 104 or else the second picture object 105, is coded with a better picture quality, i.e. more data rate is available for the coding of the first picture object 104 and of the second picture
35 object 105 than for the coding of the background picture object, the third picture object 103.

It should be noted that it is not necessary for the individual picture objects to be disjoint, but the set union of all pixels of the first picture object 104, of the second picture object 105 and of the third picture object 103 contains all pixels of the picture 100.

For the coding of the picture 100, a picture header field is provided in each case for the entire picture, various coding parameters which are identical for the coding of the entire picture being specified in said picture header field.

Thus, a segmentation specification describing the way in which the picture 100 is segmented into picture objects 103, 104; 105 is specified in the picture header field.

For the coding of the segmentation specification, two bits are provided in the picture header field. Four different types of segmentation are distinguished:

- 20 - First segmentation type (code 00):
The method described is not used for coding the picture 100.
- Second segmentation type (code 01):
All picture objects including the background picture objects are disjoint and exactly fill the predetermined picture format of the picture 100.
- 25 - Third segmentation type (code 10):
The picture objects are allowed to overlap and are also allowed to lie outside a customary picture frame. However, it lies within a predetermined frame which is larger than the customary picture frame and must not be exceeded.
- 30 - Fourth segmentation type (code 11):
With the exception of the background picture object, all picture objects are disjoint. The fourth segmentation type serves for efficient coding of the background information, since already coded background can be stored in a memory,
- 35

the background memory. Picture background exposed again by a moving picture object does not have to be newly coded again. The background is allowed to project beyond the predetermined picture frame of the picture 100 in order that, in the event of a movement of the camera 201 recording the picture 100, recourse can be had to already coded information. Once again, a prescribed frame is determined which is larger than the customary picture frame of the picture 100. This prescribed frame must not be exceeded.

In a further step (step 405), the coded information of the picture is transmitted as a coded picture from the first computer 202 to the second computer 208.

In a further step (step 406), the coded picture is received by the second computer 208.

In a last step (step 407), the received coded picture information is decoded and the digitized picture is reconstructed using the concomitantly transmitted coding parameters and the quality specification.

Different types of picture objects may occur, a respective type of a picture object being coded by a code in the header field of the respective picture object.

A first type of picture object is a rectangular picture object having a width w and a height h . On account of the correspondence of the object boundaries (edge of the picture object) to the edges of the respective macroblocks, the rectangular object is addressed by the absolute macroblock address of the top left macroblock in the rectangular picture object.

The macroblock address is an address which is assigned to the respective macroblock and uniquely identifies each macroblock in the context of picture coding.

The width w of the rectangular picture object is coded using variable length coding.

The macroblocks are addressed in such a way that in the picture 100, line by line from left to right, a respective value which represents the macroblock address is incremented from macroblock to macroblock. For the coding of a respective picture object, a picture object start code is provided which specifies that the further data relate to coding of a picture object. Consequently, the coding of the last macroblock of a picture object is in each case followed by either a new picture object start code or a new picture start code which specifies that data of a new picture are subsequently coded.

If the boundaries of the rectangular picture object do not correspond to the macroblock raster, but do correspond to the block boundaries of the luminance picture blocks, then the relative position of the respective luminance picture blocks with respect to the macroblock boundaries is coded by additional bits in the picture object header field.

Picture objects which do not have a rectangular structure are segmented in such a way that the edge of the respective picture object corresponds to the block boundaries of the macroblocks or at least to the block boundaries of the luminance picture blocks.

In this case, the first macroblock of the picture object is addressed by the absolute macroblock address in accordance with the addressing scheme described above.

The subsequent macroblocks belonging to the respective picture object are addressed using run length coding, as is known from the method in accordance with the H.261 standard.

The coding of the last macroblock in the picture object is likewise followed by either a new picture object start code or a new picture start code.

5 A third type of picture object is a background picture object; in the present case, the third picture object 103 represents a background picture object. A background picture object describes a background, the information represented in the background having less
10 significance to the observer than the information described in a foreground picture object.

In contrast to the slice structured mode disclosed in [1], the background picture object is not necessarily rectangular even in the case of a rectangular picture object, the rectangular object.

15 For the coding of a background picture object, the process begins with a picture object start code. The addressing of the macroblocks of the background picture object depends on the selected segmentation type described above.

20 In the case of the second segmentation type (code 01), the position of all the background macroblocks, i.e. all the macroblocks which are contained in the background picture object, is unambiguously determined after the coding of the last
25 picture object, and they can be successively addressed in the manner described above in accordance with the addressing of the macroblocks. Macroblocks which do not belong to the picture background need not be skipped by run length coding.

30 In the case of the second segmentation type and also in the case of the third segmentation type (code 10 and code 11), the addressing is effected as in the case of the picture objects having a non-rectangular structure.

35

A number of alternatives to the exemplary embodiment described above are explained below.

As an alternative to the variable length coding, fixed length coding can be used for coding the
5 width w of the rectangular picture object.

Differential coding from the size and the position of the rectangular picture object in a predecessor picture of the picture 100 can also be used in the context of the method.

10 An alternative to run length coding in the coding of macroblocks of a picture object which does not have a rectangular structure is so-called shape coding, as is described in [2]. Differential coding from the position of the picture object in the
15 predecessor picture can also be used for coding the macroblocks.

In the context of this method described above, provision may furthermore be made for using only rectangular picture objects. This leads to a
20 simplification in the coding since, in this case, it is only necessary to increment the macroblock address by w macroblocks when skipping macroblocks which belong to a rectangular picture object. This results in a reduction of required computation operations in the context of
25 coding.

Those picture objects which are of particular interest to an observer of the picture 100 are coded with a higher quality than the picture objects, in particular the background picture objects, which are of
30 less interest to the observer of the picture 100.

Since a block-based picture coding method is used, so-called block artifacts, i.e. visible block edges, occur to an increased extent in the picture areas coded with a lower quality.

In an alternative embodiment, said artifacts are reduced by using a block edge filter. Such a block edge filtering is disclosed in [4]. The block edge filtering can be used both in the context of decoding and in the feedback loop of the coder, as is illustrated in **Figure 3**, as so-called "filter in the loop".

The block edge filtering is preferably used only for the picture objects which are coded with coarse quantization, i.e. with a low quality.

In the event of high degree of movement within a sequence of pictures, however, it can happen, even in the case of the picture objects which are coded with increased quality, that a relatively coarse quantization has to be used for a short time on account of the limited data rate. In this case, block edge filtering is temporarily used for this time period of increased motion, which is optionally determined by assessment of the motion vectors determined for the picture objects.

The filter parameters of the filters used for block edge filtering can be dynamically adapted to the respective picture to be coded in accordance with the method disclosed in [4].

Furthermore, transmission error protection may be provided for the transmission of the coded pictures, for example a CRC code (Cyclic Redundancy Check) or else a so-called punctured code. In this case, preferably those picture objects which are coded with an increased quality are protected against transmission errors by an error protection mechanism which is "more powerful" than the error protection mechanism used for picture objects which were coded with a lower quality.

The term "more powerful" is to be understood to the effect that an increased number of transmission errors can be detected

GR 98 P 2749

- 18 -

and corrected by the respective error protection method.

In a variant, the quality specification may also be given by the specification of a spatial resolution to be chosen. For this case, the foreground object, i.e. the first picture object 104 or else the second picture object 105, is coded with a better picture quality, i.e. with a higher spatial resolution, than the background picture object, the third picture object 103.

05-12-2000 1998P02749WO
PCT/DE 99/02763

DE 009902763

- 19 -

The following publications are cited in this document:

- 5 [1] ITU-T Draft Recommendation H.263, Video Coding for
Low Bitrate Communication, September, 1997
- 10 [2] ISO/IEC JTC1/SC29/WG11, MPEG-4 Systems, Working
Draft 4.0 of ISO/IEC 14496-1, A. Eleftheriadis,
C. Herpel, L. Ward (ed.), April 16, 1997
- [3] K.-P. Karmann et al, Moving object segmentation
based on adaptive reference images, Proceedings of
EUSIPCO-90, pp. 951-954, Barcelona, September 1990
- 15 [4] DE 196 54 983 B
- [5] WO 98 15915 A (Univ. Columbia) April 16, 1998
- 20 [6] US-A-5 771 102 (Pelz Rodolfo Mann et al) June 23,
1998

AMENDED SHEET

05-12-2000 1998P02749WO
PCT/DE 99/02763

DE 009902763

- 20 -

Patent Claims

1. A method for processing a digitized picture (100) with pixels,
 - 5 a) in which the pixels are grouped into picture blocks,
 - b) in which the picture is segmented into at least a first picture object (104) and a second picture object (105), at least one picture block being
10 assigned to at least a part of an edge of the first picture object,
 - c) in which information about the picture object is assigned to the at least one picture block,
 - d) in which the picture objects are coded with
15 different quality,
 - e) in which a quality specification indicating the quality with which a picture object is coded is assigned to at least one macroblock (102) contained in the corresponding picture object, and
20 f) in which the quality is determined by a spatial resolution.
2. The method as claimed in claim 1,
 - a) in which a plurality of picture blocks are in each case grouped to form a macroblock, and
25 b) in which a macroblock is assigned at least to the part of the edge.
3. The method as claimed in claim 2,
in which at least one luminance block of the macroblock is assigned at least to the part of the edge of the
30 first picture object.
4. The method as claimed in one of claims 1 to 3,
in which at least one picture block is assigned to the entire edge of the first picture object.
5. The method as claimed in one of claims 2 to 4,
35 in which information about the picture object is in each case assigned to all the macroblocks in which the edge is contained.

AMENDED SHEET

05-12-2000 1998P02749WO
PCT/DE 99/02763

DE 009902763

- 21 -

6. The method as claimed in one of claims 2 to 5,
in which the first picture object is addressed using a
macroblock address respectively assigned to a
macroblock.
- 5 7. The method as claimed in one of claims 2 to 6,
in which the second picture object is addressed using a
macroblock address respectively assigned to a
macroblock.
8. The method as claimed in one of claims 1 to 7,
10 used for coding a digitized picture.
9. The method as claimed in one of claims 1 to 7,
used for decoding a digitized picture.
10. The method as claimed in one of claims 1 to 9,
used in a mobile communications device.
- 15 11. An arrangement for processing a digitized picture
(100) with pixels,
having a processor which is set up in such a way that
a) the pixels are grouped into picture blocks (101),
b) the picture is segmented into at least a first
20 picture object (104) and a second picture object
(105), at least one picture block being assigned
to at least a part of an edge of the first picture
object, and
c) information about the picture object is assigned
25 to the at least one picture block,
that the picture objects are coded with different
quality,
that a quality specification indicating the quality
with which a picture object is coded is assigned to at
30 least one macroblock contained in the corresponding
picture object, and
that the quality is determined by a spatial resolution.

AMENDED SHEET

05-12-2000 1998P02749WO
PCT/DE 99/02763

DE 009902763

- 22 -

12. The arrangement as claimed in claim 11,
in which the processor is set up in such a way that
- a) a plurality of picture blocks are in each case
grouped to form a macroblock, and
 - 5 b) a macroblock is assigned at least to the part of
the edge.
13. The arrangement as claimed in claim 11 or 12,
used for coding a digitized picture.
14. The arrangement as claimed in claim 11 or 12,
10 used for decoding a digitized picture.
15. The arrangement as claimed in one of claims 11 to
14,
used in a mobile communications device.

Fetherstonhaugh & Co.
Ottawa, Canada
Patent Agents

AMENDED SHEET

GR 98 P 2749

FIG 1

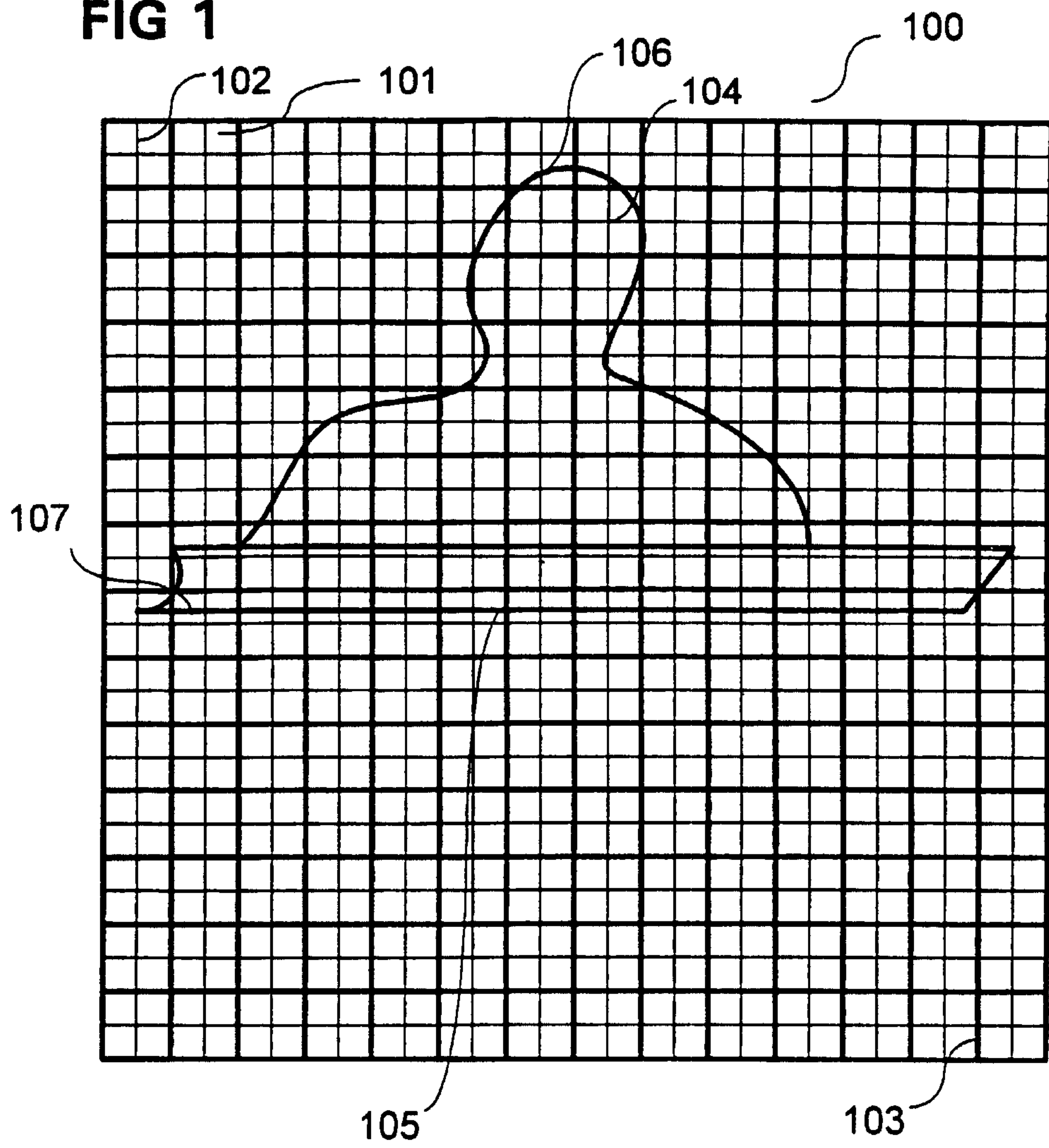

GR 98 P 2749

FIG 2

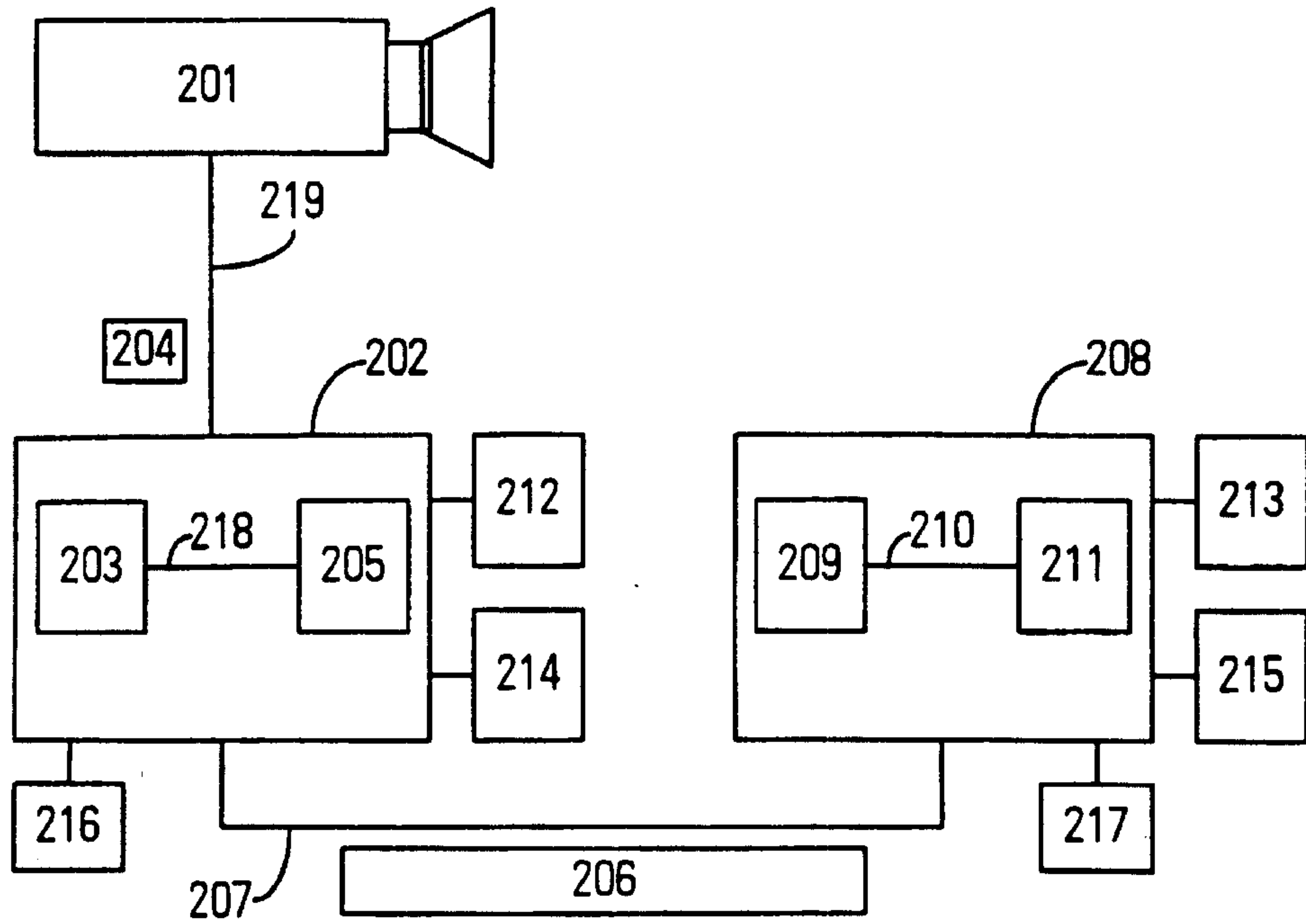

FIG 3

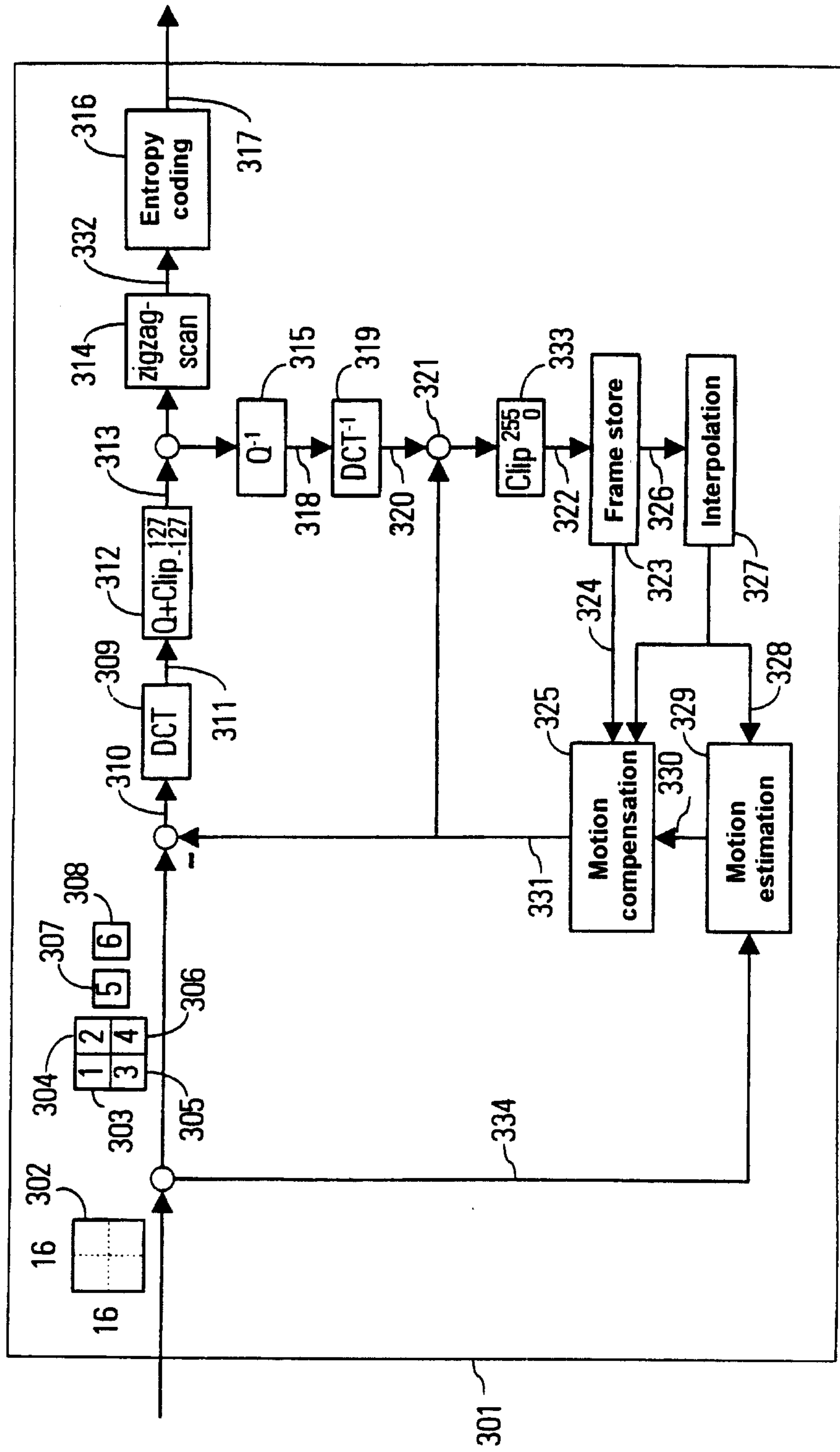

FIG 4

