

(No Model.)

G. V. HOUSE.
TRUSS PAD.

No. 593,473.

Patented Nov. 9, 1897.

Fig. 1.

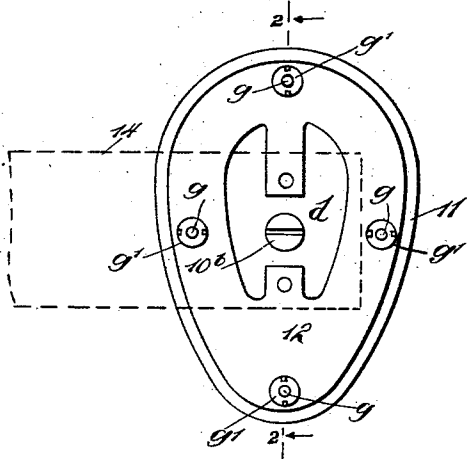

Fig. 2.

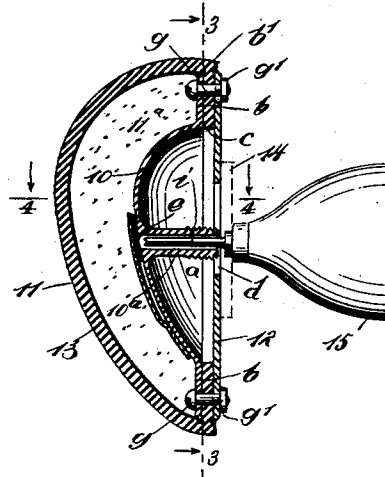

Fig. 3.

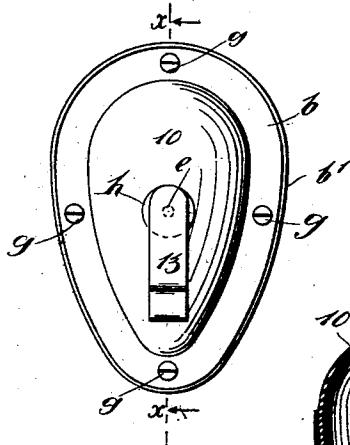

Fig. 4.

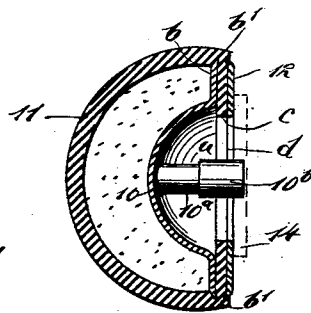
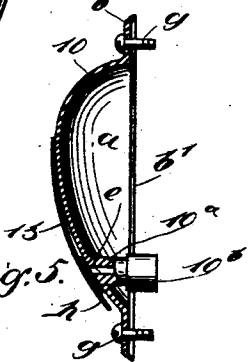

Fig. 5.



WITNESSES:
John A. Snyton
Wm. P. Patton

INVENTOR
G. V. House.
BY *Wm. P. Patton*
ATTORNEYS.

UNITED STATES PATENT OFFICE.

GEORGE V. HOUSE, OF MOUNT VERNON, NEW YORK.

TRUSS-PAD.

SPECIFICATION forming part of Letters Patent No. 593,473, dated November 9, 1897.

Application filed February 27, 1897. Serial No. 625,292. (No model.)

To all whom it may concern:

Be it known that I, GEORGE V. HOUSE, of Mount Vernon, in the county of Westchester and State of New York, have invented a new and Improved Truss-Pad Bulb and Means for Inflating the Same, of which the following is a full, clear, and exact description.

This invention relates to truss-pads of a type having elastic bulbs adapted to receive a distending medium. An object of my invention is to provide novel features of construction in a device of the indicated character, which enables the convenient inflation of the elastic bulb with air or a liquid and a graduation of distention thereof to suit the nature of the rupture to be reduced by said bulb.

A further object is to provide novel convenient means for the reliable introduction of air or water into the elastic bulb and an entire or partial removal of the distending medium, as occasion may require.

The invention consists in the novel construction and combination of parts, as is hereinafter described, and defined in the claims.

Reference is to be had to the accompanying drawings, forming a part of this specification, in which similar characters of reference indicate corresponding parts in all the figures.

Figure 1 is an outer side view of the pad-bulb, a truss-band being indicated in part by dotted lines. Fig. 2 is a longitudinal sectional view substantially on the line 2 2 in Fig. 1. Fig. 3 is an inner side view of the base-plate of the pad-bulb, the position of which is defined by the line 3 3 in Fig. 2. Fig. 4 is a transverse sectional view of the complete bulb, taken substantially on the line 4 4 in Fig. 2; and Fig. 5 is a longitudinal sectional view of the base-plate for the bulb, essentially on the line $x x$ in Fig. 3, but showing a different position for the inlet-passage and valve normally closing said passage.

In the drawings showing an embodiment of my invention, 10 represents the base-plate for the pad-bulb, said plate being concavo-convex and essentially ovate in contour, as clearly shown in Fig. 3.

A cavity a is produced in the base-plate 10, of suitable depth and preferably conforming in contour with that of the marginal edge thereon, an oval flange b that is flat projecting exteriorly from the ovate wall of the chamber a , as is clearly shown in Fig. 3.

The bulb proper consists of a measurably-elastic shell 11, that is preferably ovate in form and is provided with an inwardly-projecting flange c , that forms the border of the bulb-shell.

The dimensions of the bulb-shell 11 adapt it to receive within its cavity the base-plate 10, so that the marginal flange b of the base-plate may seat upon the inner surface of the flange c , as is shown in Figs. 2 and 4.

A clamping-plate 12 is provided for securing the base-plate 10 air or water tight upon the flange c of the pad-bulb shell 11.

The clamping-plate 12 is apertured, as at d , to permit access to a tubular stem 10^a , which projects outwardly from the concave wall of the base-plate 10 and affords a small passage e for air or water into the space between the bulb-shell 11 and base-plate 10. Preferably the edges of the flange b and clamping-plate 12 are slightly bent laterally on the sides of said parts which contact with the elastic flange c .

Small bolts g and nuts g' or equivalent means are provided to hold the flange b and clamping-plate 12 tightly drawn against the flange c , so that the angularly-bent edge b' of said flange and the edge of the clamping-plate may be embedded in the yielding material of the flange c of the shell 11.

A plate-spring 13 is secured on the convex inner side of the base-plate 10 and projects over the passage e in the tubular stem 10^a , where it intersects the bulb-chamber 11^a , formed between the inner surfaces of the base-plate 10 and bulb-shell 11, and a sealing-pad h is secured on the free end of said spring, which by the tension of the spring is held pressed over the passage e , as is clearly shown in Fig. 2. The tubular stem 10^a is furnished with a sealing-cap 10^b , that engages the threaded body of said stem at its outer end.

The pad-bulb in completed form is to be secured upon a truss-band 14, (shown by dotted lines in Figs. 1, 2, and 4,) the means of attachment being such as will permit a convenient disconnection of the parts named when occasion requires.

It is designed to inflate the elastic bulb-shell 11 by the enforced introduction of air or water within the bulb-chamber 11^a through the passage e . To readily effect the inflation,

I have provided a liquid or air pump comprising the common collapsible bulb 15. (Shown partially in Fig. 2.) On the open end of the bulb 15 a slim nozzle-tube *i* is secured, through which air or liquid enters the ovate bulb 15 and is ejected therefrom when said bulb is manipulated in the usual way. The nozzle-tube *i* is of a diameter which permits its easy insertion into the passage *e* of the tubular stem 10^a, and the length of the nozzle-tube enables the operator to raise the sealing-pad on the end of the spring-finger 13, so as to permit a free introduction of air or liquid into the bulb-chamber 11^a.

In Fig. 5 the base-plate 10 is shown detached and having the tubular stem 10^a located near one end of the ovate cavity *a* of said base-plate. This disposition of the stem and a corresponding change of location of the plate-spring valve 13, so as to seal the passage *e*, is preferred when the bulb is to be distended with water, as this can be better effected if the inlet-passage for liquid is at nearly the highest point in the bulb-chamber, the bulb being then held so that the end having the tubular stem will be uppermost, which will allow air to escape as the liquid is forced in.

It will be seen that the elastic bulb-shell 11 can, by the introduction of air or water within the chamber 11^a, be rendered more or less yielding, it becoming less elastic or more nearly approaching rigid condition as the distention is increased.

Should there be too great a distention of the bulb-shell for the comfort of the wearer of the truss, the patient can by use of the air or liquid injecting pump hereinbefore described withdraw a portion of the air or liquid, so as to render the bulb-shell more elastic.

The peculiar construction of the base-plate 10 adapts the truss-bulb for inflation with a small quantity of air or water, as the dished form of the base-plate reduces the capacity of the chamber 11^a, that receives the distending medium. Furthermore, the pump being capable of withdrawing air or water as well as forcing such air or liquid facilitates the proper inflation or distention of the pad-bulb. The provision of the sealing-cap 10^b for the free end of the stem 10^a is made to prevent any possible escape of air or liquid from the bulb.

It is claimed for the improvements that an

elastically-adjustable pad-bulb is afforded which is novel in details, is very convenient to adjust by the wearer, has a range of elasticity not provided in other elastic pad-bulbs, is reliable in use, and may be produced at a moderate cost.

It is evident that the truss-pad bulb may be nearer circular than is shown and described, or be circular, if such a form of the device is desired, the base-plate and clamping-plate in such a case being shaped to conform with the periphery of the elastic bulb-shell.

Having thus described my invention, I claim as new and desire to secure by Letters Patent—

1. In a truss-pad, the combination with an elastic bulb-shell, having an inwardly extended marginal flange, a concaved base-plate having a flat margin which seats on the inner side of the bulb-shell flange, and a clamping-plate secured to the base-plate, and compressing the flange of the bulb-shell between it and said base-plate, of a tubular stem projecting from the concavity of the base-plate, and a spring-plate valve covering the bore of the stem in the base-plate, substantially as described.

2. In a truss-pad of the character described, the concaved base-plate, the tubular stem extending therefrom, the plate-spring valve covering the bore of the stem through the base-plate, and the screw-cap closing the free end of the tubular stem, substantially as described.

3. In a truss-pad, the combination with an elastic bulb-shell having a marginal flange, of a base-plate secured to the interior side of said flange, a tubular stem projecting from the outer side of the base-plate, and a plate-spring valve secured by one end on the interior side of the base-plate and normally closing the bore of the tubular stem at its inner end, substantially as described.

4. The combination of the pad having a curved wall and an inflating-opening therein, and a plate-spring located within the pad along said curved wall and carrying a valve adapted to close said opening, substantially as described.

GEORGE V. HOUSE.

Witnesses:

WM. P. PATTON,
JNO. M. RITTER.