



INTERNATIONAL APPLICATION PUBLISHED UNDER THE PATENT COOPERATION TREATY (PCT)

<p>(51) International Patent Classification ⁷ : A61B 17/86</p>	<p>A1</p>	<p>(11) International Publication Number: WO 00/61022 (43) International Publication Date: 19 October 2000 (19.10.00)</p>
<p>(21) International Application Number: PCT/EP00/02953 (22) International Filing Date: 3 April 2000 (03.04.00) (30) Priority Data: 99830204.6 8 April 1999 (08.04.99) EP (71) Applicant (for all designated States except US): ORTHOFIX S.R.L. [IT/IT]; Piazzale Principessa Clotilde, 8, I-20121 Milano (IT). (72) Inventor; and (75) Inventor/Applicant (for US only): VENTURINI, Daniele [IT/IT]; Via Di Vittorio, 7, I-37065 Povegliano Veronese (IT). (74) Agents: BOTTI Mario et al.; Botti & Ferrari S.r.l., Via A. Locatelli, 5, I-20124 Milano (IT).</p>		<p>(81) Designated States: AE, AG, AL, AM, AT, AU, AZ, BA, BB, BG, BR, BY, CA, CH, CN, CR, CU, CZ, DE, DK, DM, DZ, EE, ES, FI, GB, GD, GE, GH, GM, HR, HU, ID, IL, IN, IS, JP, KE, KG, KP, KR, KZ, LC, LK, LR, LS, LT, LU, LV, MA, MD, MG, MK, MN, MW, MX, NO, NZ, PL, PT, RO, RU, SD, SE, SG, SI, SK, SL, TJ, TM, TR, TT, TZ, UA, UG, US, UZ, VN, YU, ZA, ZW, ARIPO patent (GH, GM, KE, LS, MW, SD, SL, SZ, TZ, UG, ZW), Eurasian patent (AM, AZ, BY, KG, KZ, MD, RU, TJ, TM), European patent (AT, BE, CH, CY, DE, DK, ES, FI, FR, GB, GR, IE, IT, LU, MC, NL, PT, SE), OAPI patent (BF, BJ, CF, CG, CI, CM, GA, GN, GW, ML, MR, NE, SN, TD, TG).</p> <p>Published With international search report.</p>
<p>(54) Title: IMPROVED BONE SCREW FOR USE IN ORTHOPAEDIC SURGERY</p>		
<p>(57) Abstract</p> <p>The invention relates to an improved bone screw for use in orthopaedic surgery, in particular with external fracture fixation devices, of the type which comprises a head (3), a shank (4), and a threaded portion (5) tapering towards a tip (2) at the opposite end from the head (3). Advantageously, the threaded portion (5) has at least one constant pitch section comprising threads (9) which have a triangular cusp-like profile in cross-section and are separated from each other by a shaped bottom land with a concave profile (10) defined by two countersloping planes.</p>		

FOR THE PURPOSES OF INFORMATION ONLY

Codes used to identify States party to the PCT on the front pages of pamphlets publishing international applications under the PCT.

AL	Albania	ES	Spain	LS	Lesotho	SI	Slovenia
AM	Armenia	FI	Finland	LT	Lithuania	SK	Slovakia
AT	Austria	FR	France	LU	Luxembourg	SN	Senegal
AU	Australia	GA	Gabon	LV	Latvia	SZ	Swaziland
AZ	Azerbaijan	GB	United Kingdom	MC	Monaco	TD	Chad
BA	Bosnia and Herzegovina	GE	Georgia	MD	Republic of Moldova	TG	Togo
BB	Barbados	GH	Ghana	MG	Madagascar	TJ	Tajikistan
BE	Belgium	GN	Guinea	MK	The former Yugoslav Republic of Macedonia	TM	Turkmenistan
BF	Burkina Faso	GR	Greece			TR	Turkey
BG	Bulgaria	HU	Hungary	ML	Mali	TT	Trinidad and Tobago
BJ	Benin	IE	Ireland	MN	Mongolia	UA	Ukraine
BR	Brazil	IL	Israel	MR	Mauritania	UG	Uganda
BY	Belarus	IS	Iceland	MW	Malawi	US	United States of America
CA	Canada	IT	Italy	MX	Mexico	UZ	Uzbekistan
CF	Central African Republic	JP	Japan	NE	Niger	VN	Viet Nam
CG	Congo	KE	Kenya	NL	Netherlands	YU	Yugoslavia
CH	Switzerland	KG	Kyrgyzstan	NO	Norway	ZW	Zimbabwe
CI	Côte d'Ivoire	KP	Democratic People's Republic of Korea	NZ	New Zealand		
CM	Cameroon			PL	Poland		
CN	China	KR	Republic of Korea	PT	Portugal		
CU	Cuba	KZ	Kazakistan	RO	Romania		
CZ	Czech Republic	LC	Saint Lucia	RU	Russian Federation		
DE	Germany	LI	Liechtenstein	SD	Sudan		
DK	Denmark	LK	Sri Lanka	SE	Sweden		
EE	Estonia	LR	Liberia	SG	Singapore		

- 1 -

Improved bone screw for use in orthopaedic surgery**DESCRIPTION**Technical Field

This invention relates to an improved bone screw for use in
5 orthopaedic surgery, specifically in devices for the external fixation of bone
fractures.

More particularly, the invention relates to a screw having a head or
application end, a shank, and a threaded portion, which tapers towards a
tip at the opposite end from the application end.

10 Background Art

As is well known, a variety of external fixation devices are currently
employed with increasing frequency in human as well as veterinary
orthopaedic surgical procedures for treating complex fractures and/or
fractures associated with serious damage to the cutaneous tissue.

15 Devices of this kind allow broken bones to be consolidated and
reduced in highly critical areas of the human bony structure, especially
near joints.

Customarily, the opposite ends of an external fixation device are
secured to respective undamaged portions of a broken bone by means of
20 bone screws set in the bone itself. Such is the case, for example, with a
tibial fixation device having opposite ends firmly secured across the
fracture to the shinbone.

In other cases, such as when the fracture affects a joint, the bone
screws are set in bones adjacent to the joint. This is done, for example,
25 with an ankle external fixation device by setting the bone screws in the
tibia and the talus.

The effectiveness of such devices improves with the holding power of
their bone screws. In some cases, the screws extend transversely through
the bone to affect entrance and exit cortical regions.

30 A comprehensive literature exists in this specific technical field on
research work directed to determine the critical parameters that control
the holding power of bone screws.

As an example, it has been found that a relatively fine thread
improves the holding power of the screw, as described in an article
35 "Cortical profile external fixation screw maintains torque in the
metaphysis", Anatomy, Bristol, June 17, 1996.

A radial preload on the screw prevents or attenuates the problem of

- 2 -

the loss of grip or lysis in the first and/or the second cortical portion of the bone, as described in an article "Introduction and prevention of pin loosening in external fixation", Journal of Orthopaedic Trauma, Vol. 5, No. 4, pages 485-492.

5 Furthermore, providing a hole in the bone prior to inserting the screw, according to the screw diameter, lowers the insertion temperature which, if excessively high, can hurt the particular bone connective tissue around the screw, as described in an article "Cancellous Bone Screw Thread Design and Holding Power", Journal of Orthopaedic Trauma, Vol.
10 10, No. 7, pages 462-469.

The foregoing considerations lead to conclude that the holding power of a bone screw may be dependent on a series of features having a synergic combined effect.

15 However, application studies carried out at the Applicant's have resulted in the thread profile being identified as the fundamental factor of the screw holding power in the bone.

20 In particular, it has been found that conventional thread profiles have a common drawback in that they only provide an inferior distribution of the stress from the force applied to penetrate the cortical portion of the bone.

In addition, conventional bone screws are of greater bulk for a given area of bone interface.

25 The underlying technical problem of this invention is to provide an improved bone screw having such structural and functional features as to effectively produce a self-tapping penetrative action during its insertion in the bone, and exhibiting improved holding power once in place, thereby overcoming all the drawbacks discussed hereinabove in connection with the prior art.

Disclosure of Invention

30 The concept of this invention is one of providing a bone screw with a self-tapping threaded portion which includes at least one constant pitch section comprised of threads having a triangular cusp profile in cross-section and being separated from each other by a shaped bottom land with a concave profile defined by two countersloping planes. This allows
35 the elongate conical profile of the threaded portion to be put to best use, and affords a large area of contact with the bone effective to reduce the specific loading pressure.

- 3 -

Based on this concept, the technical problem is solved by a bone screw as previously indicated and defined in the characterising portions of Claim 1 following.

5 The features and advantages of a bone screw according to the invention will be apparent from the following description of an embodiment thereof, given by way of non-limiting example with reference to the accompanying drawings.

Brief Description of Drawings

10 Figure 1 is a perspective view showing schematically a bone screw according to this invention.

Figure 2 is a schematic side elevation view of the screw shown in Figure 1.

Figure 3 shows schematically, drawn to an enlarged scale, a portion of the thread profile of the screw in Figure 1.

15 Figure 4 shows, drawn to a further enlarged scale, a detail of the thread profile of Figure 3.

Figures 5A and 5B are respective enlarged views showing schematically the tip end of the screw of Figure 1, as viewed from two different angles.

20 Figure 6 is an enlarged front view showing schematically the tip end of the screw in Figure 1.

Figure 7 is a schematic detail view of the head end of the screw in Figure 1.

Modes for carrying out the Invention

25 Referring to the drawing views, in particular to the example of Figure 1, generally and schematically shown at 1 is a bone screw according to this invention intended for use in human or animal orthopaedic surgery with devices for the external fixation of bone fractures.

30 The screw 1 has a tip end 2 adapted to be implanted by a surgeon into the cortical portion of a bone, and then driven in a threaded manner by means of a tool applied to a head end 3 of the screw.

35 The screw 1 comprises a shank 4 and a threaded portion 5 formed integral with the shank 4. The threaded portion 5 has an elongate conical shape and the same diameter as the shank 4 at its region adjoining the shank, to then taper slightly in the direction towards the tip end 2. The threaded portion 5 accounts for about one third of the screw overall length. However, another length ratio of the threaded portion 5 to the

- 4 -

shank 4 could be chosen instead.

Advantageously, the screw is of the self-tapping type in that it is formed with a helical thread pattern which can be termed directional in the sense that it will retain its drive direction more effectively even when applied a high torque.

Figure 3 is an enlarged view of the profile of the threaded portion according to the invention.

Advantageously, the threaded portion has at least a section formed with a constant pitch, preferably a 1.25mm pitch, and comprises threads 9 having a triangular profile in cross-section with a cusp or acute apex angle of 15° to 30°.

The facing walls of two adjacent threads form an acute angle α of conical convergence towards the longitudinal axis X of the screw. In the embodiment of Figure 4, this angle is preferably no more than 30°.

Advantageously, the bottom land of the threads is shaped with a concave cross-section 10 between adjacent threads 9, effective to ease the material flow and relieve bone stress during the screw penetration.

The concave 10 is defined by two countersloping planes forming in cross-section an obtuse angle β of conical convergence towards the longitudinal axis of the screw. This obtuse angle is in the 120° to 150° range, preferably of 150° in the embodiment of Figure 3.

The region between the inner walls and the bottom land of the threads 9 is radiused to a radius of 0.2mm.

The thread height is three fifths the pitch, i.e. 0.75mm. It is constant along the profile 5.

This thread allows the conical profile to be used at its best by concentrating the drag in the opposite direction to the driving/piercing direction.

By way of illustration only, the screw 1 may have an overall length of 175mm, inclusive of 60mm of threaded portion 5.

A variety of lengths may be contemplated to provide the surgeon with a range of bone screws to use according to necessity. For example, a suitable range might include screws with an overall length of 140mm, including 40mm of threaded portion; or screws 210mm long with a 70mm threaded portion; or screws 255mm long with a threaded portion of at least 80mm.

Where the screw is 175mm long, the shank diameter is preferably of

- 5 -

6mm, same as the outside diameter of the threaded portion 5 at the shank 4. At the tip end 2, the outside diameter of the threaded portion becomes 4mm.

Accordingly, the core diameter of the threaded portion will be 4.5mm at the shank, and 2.5mm at the tip.

Advantageously, the tip 2 of the screw 1 is formed with a pair of oppositely located grooves 11, 12 cut by straight-line milling.

The grooves extend at a predetermined inclination angle ϕ with respect to the longitudinal axis of the screw 1, and interfere with an end section of the threaded portion 5 near the tip.

The inclination angle ϕ is preferably of 150°.

The provision of such a groove pair allows the screw to be readily started into a hole pre-drilled through the bone, but also allows the section of the threaded portion that adjoins the tip and has not been removed to interfere with the second cortical portion of the bone.

To complete this description, it should be added that an annular groove 15 is provided near the head 3 of the screw 1 to facilitate cutting off a portion of the screw as may ultimately be protruding from the fixation device.

The screw of this invention is applied in a known manner in the art, with the one difference that the bone is pre-drilled in order to provide a suitable radial pre-load and keep the insertion temperature low.

Tests were conducted at the Applicant's, and finite element (FEM) calculations carried out on prototypes of a bone screw having the previously described thread profile.

The calculations were carried out to evaluate the effect of the two different thread profiles on a cancellous bone matrix in three distinct loading situations:

- 1) screw/bone interference;
- 2) pull-out force;
- 3) simulated actual loading.

It should be noted that the analysis of the stresses induced in the bone is not of absolute value, because of the bone being no linear elastic material. Accordingly, the values from the FEM analysis only become meaningful on a comparative basis, and in particular when compared with those for conventional bone screws used as references.

Loading situation (1) arises from the insertion of a thread having a

- 6 -

5mm diameter (average of the conical diameter of the screw 1) and a thread height of 0.75mm. This means that the core diameter of the threaded portion is 3.5mm. A thread such as this was inserted through a 3.2mm hole. Under these conditions, the screw is working at a so-called interference "i" given as: (screw core diameter - hole diameter)/2 = (3.5 - 3.2)/2 = 0.15mm.

Pull-out situation (2) applies to the threaded screw being subjected to a specific unit tension ($p=1 \text{ N/mm}^2 = 1 \text{ MPa}$) in order to investigate its effect on a bonded cancellous bone. This situation simulates the pull-out effect in the absence of screw/bone interference, that is, similar to bone lysis situations.

Actual loading situation (3) is given by the combination of the previous two situations. In particular, a loading situation was simulated at an interference $i=0.15\text{mm}$ and a specific pull-out force of 8.5 MPa.

Now, the results of the FEM analysis, which have been summarized herein not to overburden the rest of the description, show that the screw of this invention distributes the stress better than conventional screws.

Furthermore, the pattern of the highest compressive stress from the pulling out shows that the screw of this invention transfers the stress onto several threads, whereas with conventional screws a single thread is mostly involved.

Finally, the screw of this invention shows to have a better distributed compression even in the absence of interference, that is in situations of an oversize pre-drilled hole, lysis or osteoporosis.

Thus, the bone screw according to the invention does solve the technical problem, and affords a number of advantages, outstanding among which is the fact that the thread profile of the screw allows the bone stress to be optimised, both as a result of the large area of contact with the bone and of the possibility given to the bony material to relax into the concave root lands of the threads. This allows the specific pressure under loading and the torque for screw penetration to be smaller.

- 7 -

CLAIMS

1. An improved bone screw for use in orthopaedic surgery, in particular with external fracture fixation devices, of the type which comprises a head (3), a shank (4), and a threaded portion (5) tapering
5 towards a tip (2) at the opposite end from the head (3), wherein said threaded portion (5) has at least one constant pitch section comprising threads (9) with an acute angle or cusp-like triangular profile in cross-section, characterised in that said threads (9) are separated from each other by a shaped bottom land having a concave profile (10) defined by
10 two countersloping planes.
2. A bone screw according to Claim 1, characterised in that said shaped bottom land has in cross-section an obtuse angle (β) of conical convergence towards the longitudinal axis of the screw.
3. A bone screw according to Claim 2, characterised in that said
15 obtuse angle (β) is an angle of at least 150° .
4. A bone screw according to Claim 1, characterised in that said cusp forms an angle in the 15° to 30° range.
5. A bone screw according to Claim 1, characterised in that said constant pitch is of 1.25mm.
- 20 6. A bone screw according to Claim 1, characterised in that the facing walls of adjacent threads have in cross-section an acute angle (α) of conical convergence towards the longitudinal axis of the screw.
7. A bone screw according to Claim 6, characterised in that said acute angle (α) is an angle in the 15° to 30° range.
- 25 8. A bone screw according to Claim 1, characterised in that the threaded portion (5) accounts for about one third of the screw length.
9. A bone screw according to Claim 1, characterised in that the height of the thread is three fifths the pitch length.
10. A bone screw according to Claim 9, characterised in that said
30 height is 0.75mm.

1/1

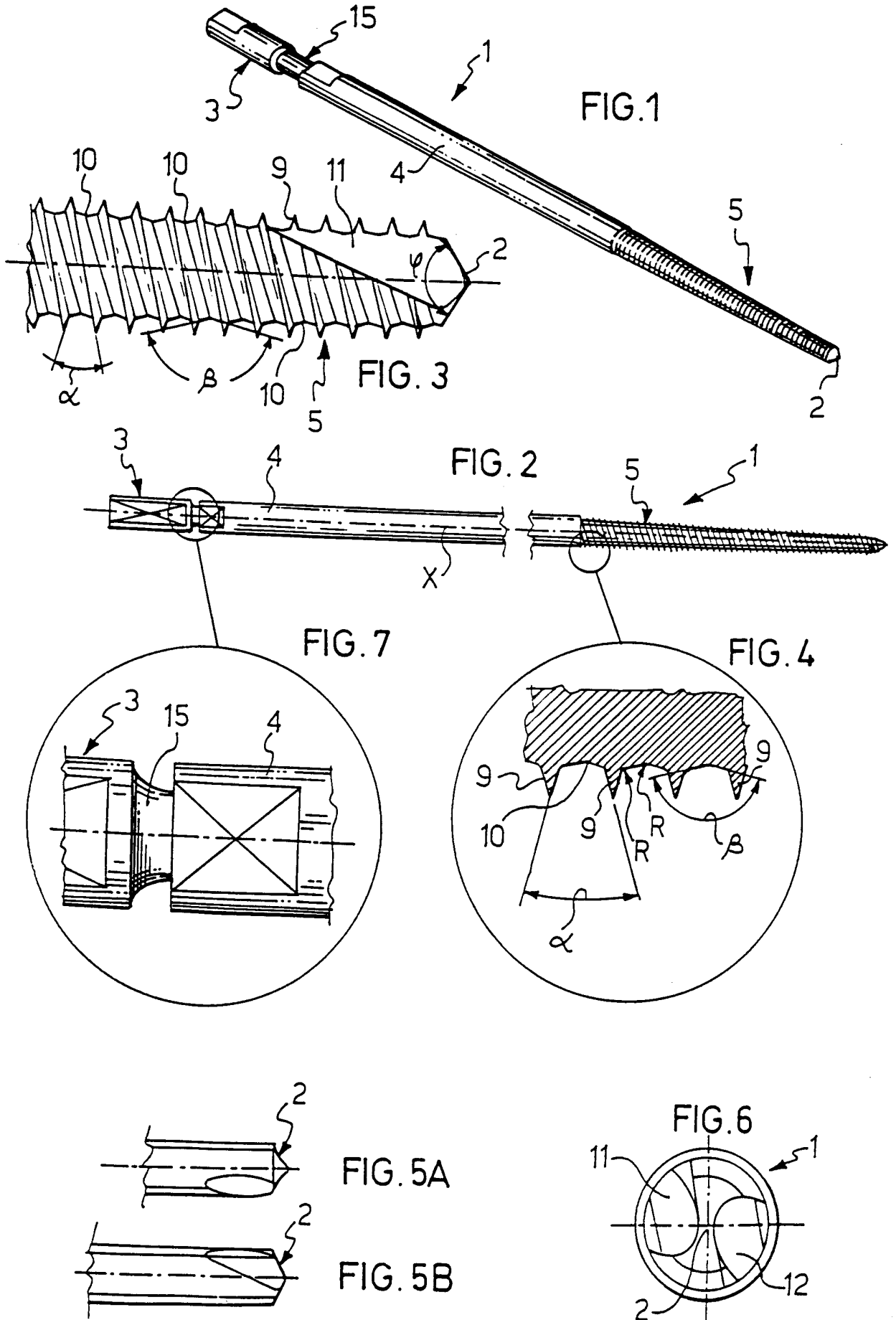

INTERNATIONAL SEARCH REPORT

International Application No PCT/EP 00/02953
--

A. CLASSIFICATION OF SUBJECT MATTER
IPC 7 A61B17/86

According to International Patent Classification (IPC) or to both national classification and IPC

B. FIELDS SEARCHED

Minimum documentation searched (classification system followed by classification symbols)
IPC 7 A61B F16B

Documentation searched other than minimum documentation to the extent that such documents are included in the fields searched

Electronic data base consulted during the international search (name of data base and, where practical, search terms used)
EPO-Internal, WPI Data

C. DOCUMENTS CONSIDERED TO BE RELEVANT

Category *	Citation of document, with indication, where appropriate, of the relevant passages	Relevant to claim No.
Y	US 4 463 753 A (GUSTILO) 7 August 1984 (1984-08-07) abstract; figures 1-4 column 2, line 36 -column 3, line 11 ---	1-5,8-10
Y	DE 43 29 788 A (MAUK ET AL.) 9 March 1995 (1995-03-09) the whole document ---	1-5,8-10
A	FR 1 266 386 A (MUELLER) 10 November 1961 (1961-11-10) the whole document ---	1-5
A	US 5 505 736 A (REIMELS ET AL.) 9 April 1996 (1996-04-09) abstract; figures ---	1-5
	-/--	

Further documents are listed in the continuation of box C.
 Patent family members are listed in annex.

* Special categories of cited documents :

<p>"A" document defining the general state of the art which is not considered to be of particular relevance</p> <p>"E" earlier document but published on or after the international filing date</p> <p>"L" document which may throw doubts on priority claim(s) or which is cited to establish the publication date of another citation or other special reason (as specified)</p> <p>"O" document referring to an oral disclosure, use, exhibition or other means</p> <p>"P" document published prior to the international filing date but later than the priority date claimed</p>	<p>"T" later document published after the international filing date or priority date and not in conflict with the application but cited to understand the principle or theory underlying the invention</p> <p>"X" document of particular relevance; the claimed invention cannot be considered novel or cannot be considered to involve an inventive step when the document is taken alone</p> <p>"Y" document of particular relevance; the claimed invention cannot be considered to involve an inventive step when the document is combined with one or more other such documents, such combination being obvious to a person skilled in the art.</p> <p>"&" document member of the same patent family</p>
--	--

Date of the actual completion of the international search 23 June 2000	Date of mailing of the international search report 29/06/2000
--	---

Name and mailing address of the ISA European Patent Office, P.B. 5818 Patentlaan 2 NL - 2280 HV Rijswijk Tel. (+31-70) 340-2040, Tx. 31 651 epo nl, Fax: (+31-70) 340-3016	Authorized officer Giménez Burgos, R
--	--

INTERNATIONAL SEARCH REPORT

International Application No
PCT/EP 00/02953

C.(Continuation) DOCUMENTS CONSIDERED TO BE RELEVANT

Category	Citation of document, with indication, where appropriate, of the relevant passages	Relevant to claim No.
A	US 3 915 162 A (MILLER) 28 October 1975 (1975-10-28) abstract; figures column 2, line 23-28 -----	1
A	EP 0 012 441 A (EBERHARD JAEGER GMBH & CO. KG) 25 June 1980 (1980-06-25) page 7, line 2 -page 8, line 25; figure 2 -----	1-7

INTERNATIONAL SEARCH REPORT

Intern. Application No
PCT/EP 00/02953

Patent document cited in search report	Publication date	Patent family member(s)	Publication date
US 4463753 A	07-08-1984	CA 1162124 A	14-02-1984
DE 4329788 A	09-03-1995	NONE	
FR 1266386 A	10-11-1961	NONE	
US 5505736 A	09-04-1996	NONE	
US 3915162 A	28-10-1975	NONE	
EP 0012441 A	25-06-1980	DE 2853976 A	19-06-1980
		DE 2948595 A	11-06-1981