



(86) Date de dépôt PCT/PCT Filing Date: 2011/04/19  
 (87) Date publication PCT/PCT Publication Date: 2012/01/19  
 (85) Entrée phase nationale/National Entry: 2013/01/10  
 (86) N° demande PCT/PCT Application No.: US 2011/033098  
 (87) N° publication PCT/PCT Publication No.: 2012/009035  
 (30) Priorité/Priority: 2010/07/12 (US12/834,237)

(51) Cl.Int./Int.Cl. *B65D 21/032* (2006.01),  
*B65D 25/20* (2006.01), *B65D 25/28* (2006.01),  
*B65D 67/02* (2006.01), *B65D 69/00* (2006.01)  
 (71) Demandeur/Applicant:  
 ENVIRONMENTAL CONTAINER SYSTEMS, INC. D/B/A  
 ECS COMPOSITES, US  
 (72) Inventeur/Inventor:  
 BECKLIN, DENNIS M., US  
 (74) Agent: SMART & BIGGAR

(54) Titre : SYSTEME DE GERBAGE HYBRIDE POUR CONTENANTS  
 (54) Title: HYBRID STACKING SYSTEM FOR CONTAINERS

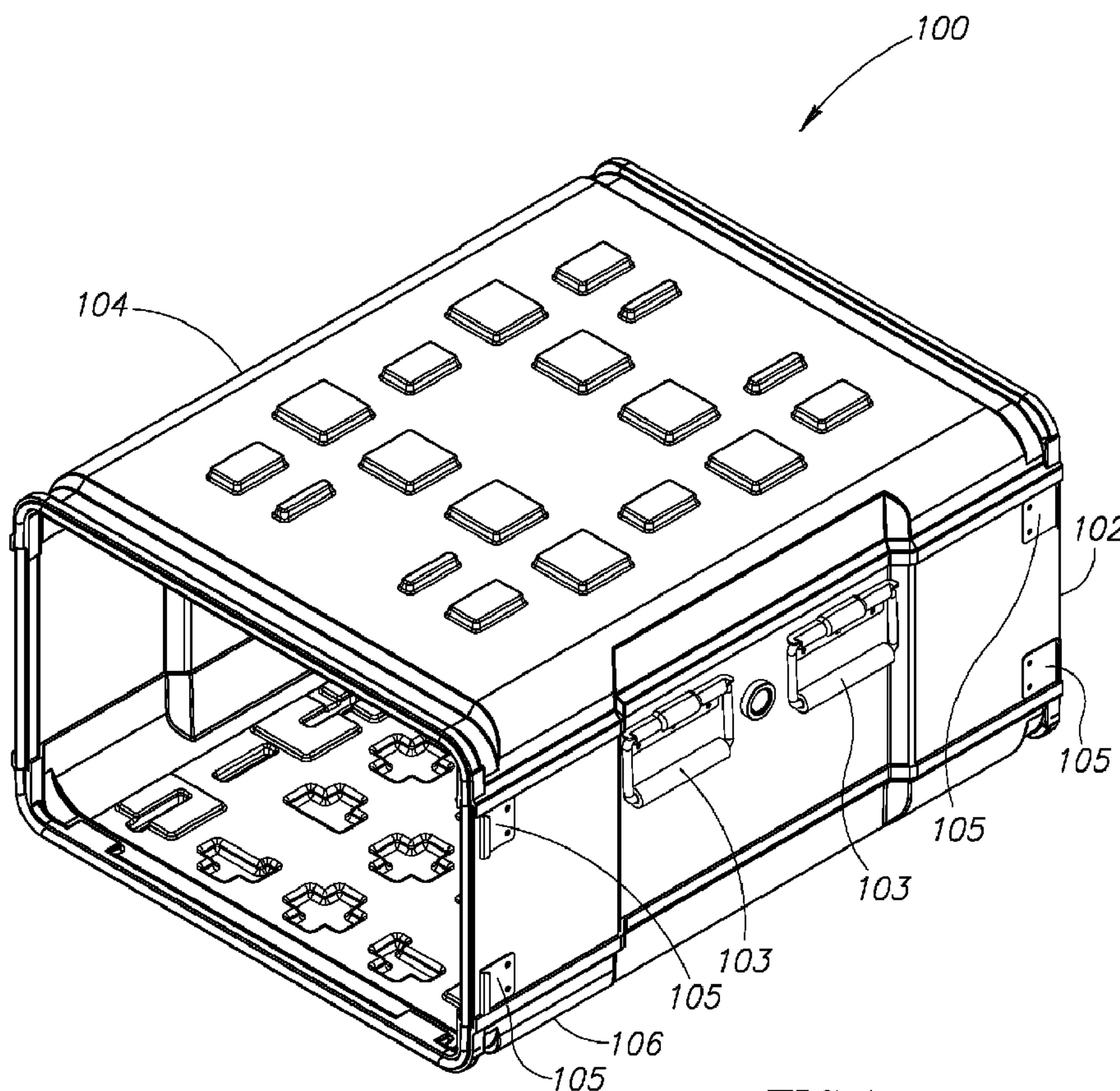

FIG.1

(57) Abrégé/Abstract:

Universal wraps are used in the construction of a container centerbody. The wraps may take the form of a top and bottom wrap with complementary stacking patterns, in which the wraps create the centerbody. The wraps permit stacking of different-style

(57) **Abrégé(suite)/Abstract(continued):**

containers regardless of which container is positioned as the bottom container. The universal wraps may include curved edge portions to seamlessly and aesthetically blend in with a side panel of the container. The stacking patterns of the wraps may take different forms with various shaped protuberances and recessed portions. Further, one or more of the wraps may have isolation features attached to or integrally formed with an interior surface of the wrap.

(12) INTERNATIONAL APPLICATION PUBLISHED UNDER THE PATENT COOPERATION TREATY (PCT)

(19) World Intellectual Property Organization  
International Bureau(43) International Publication Date  
19 January 2012 (19.01.2012)(10) International Publication Number  
**WO 2012/009035 A1**

## (51) International Patent Classification:

*B65D 21/032* (2006.01)    *B65D 25/28* (2006.01)  
*B65D 67/02* (2006.01)    *B65D 25/20* (2006.01)  
*B65D 69/00* (2006.01)

## (21) International Application Number:

PCT/US2011/033098

## (22) International Filing Date:

19 April 2011 (19.04.2011)

## (25) Filing Language:

English

## (26) Publication Language:

English

## (30) Priority Data:

12/834,237    12 July 2010 (12.07.2010)    US

(71) Applicant (for all designated States except US): **ENVIRONMENTAL CONTAINER SYSTEMS, INC. D/B/A ECS COMPOSITES** [US/US]; 3560 Rogue River Highway, Grants Pass, OR 97528 (US).

## (72) Inventor; and

(75) Inventor/Applicant (for US only): **BECKLIN, Dennis, M.** [US/US]; 3560 Rogue River Highway, Grants Pass, OR 97528 (US).(74) Agent: **LOWE, David, A.**; Black Lowe & Graham, PLLC, 701 Fifth Avenue, Suite 4800, Seattle, WA 98104 (US).

(81) Designated States (unless otherwise indicated, for every kind of national protection available): AE, AG, AL, AM, AO, AT, AU, AZ, BA, BB, BG, BH, BR, BW, BY, BZ, CA, CH, CL, CN, CO, CR, CU, CZ, DE, DK, DM, DO, DZ, EC, EE, EG, ES, FI, GB, GD, GE, GH, GM, GT, HN, HR, HU, ID, IL, IN, IS, JP, KE, KG, KM, KN, KP, KR, KZ, LA, LC, LK, LR, LS, LT, LU, LY, MA, MD, ME, MG, MK, MN, MW, MX, MY, MZ, NA, NG, NI, NO, NZ, OM, PE, PG, PH, PL, PT, RO, RS, RU, SC, SD, SE, SG, SK, SL, SM, ST, SV, SY, TH, TJ, TM, TN, TR, TT, TZ, UA, UG, US, UZ, VC, VN, ZA, ZM, ZW.

(84) Designated States (unless otherwise indicated, for every kind of regional protection available): ARIPO (BW, GH, GM, KE, LR, LS, MW, MZ, NA, SD, SL, SZ, TZ, UG, ZM, ZW), Eurasian (AM, AZ, BY, KG, KZ, MD, RU, TJ, TM), European (AL, AT, BE, BG, CH, CY, CZ, DE, DK, EE, ES, FI, FR, GB, GR, HR, HU, IE, IS, IT, LT, LU, LV, MC, MK, MT, NL, NO, PL, PT, RO, RS, SE, SI, SK, SM, TR), OAPI (BF, BJ, CF, CG, CI, CM, GA, GN, GQ, GW, ML, MR, NE, SN, TD, TG).

## Published:

- with international search report (Art. 21(3))
- before the expiration of the time limit for amending the claims and to be republished in the event of receipt of amendments (Rule 48.2(h))

(54) Title: HYBRID STACKING SYSTEM FOR CONTAINERS

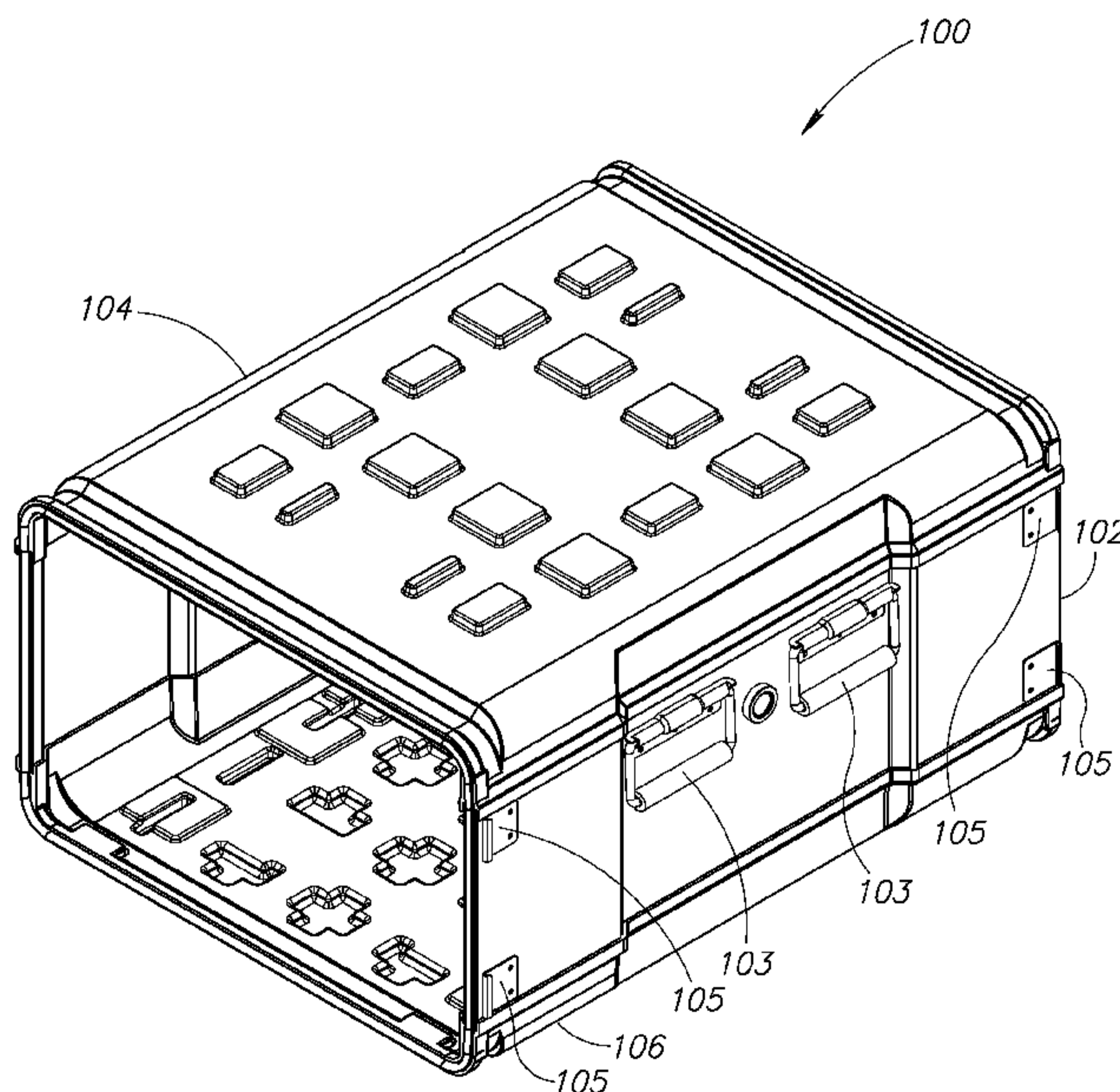

FIG.1

(57) Abstract: Universal wraps are used in the construction of a container centerbody. The wraps may take the form of a top and bottom wrap with complementary stacking patterns, in which the wraps create the centerbody. The wraps permit stacking of different-style containers regardless of which container is positioned as the bottom container. The universal wraps may include curved edge portions to seamlessly and aesthetically blend in with a side panel of the container. The stacking patterns of the wraps may take different forms with various shaped protuberances and recessed portions. Further, one or more of the wraps may have isolation features attached to or integrally formed with an interior surface of the wrap.



WO 2012/009035 A1

## **HYBRID STACKING SYSTEM FOR CONTAINERS**

INVENTOR  
Dennis M. Becklin

### **PRIORITY CLAIM**

[0001] This application claims priority to U.S. Application Serial No. 12/834,237 filed July 12, 2010, which is hereby incorporated by reference.

### **FIELD OF THE INVENTION**

[0002] This invention relates to a hybrid stacking system for containers having different stacking patterns, and more specifically relates to a hybrid stacking system having wraps on the containers for engaging different stacking patterns from different generations.

### **BACKGROUND OF THE INVENTION**

[0003] Various types of containers, which may take the form of transit containers, rack-mount containers, tote containers or another type of container, are often utilized to receive and support delicate cargo, such as, but not limited to electronic, computer, optical and other types of equipment. These containers are often used in military and commercial environments and may be handled by persons, loading equipment, or both during transit and at other times. At least some of these containers have been designed to be stackable, and thus they include stacking elements or features arranged in a desired pattern. However, many of these containers may be of different types, sizes, models and versions, and thus have different stacking patterns that either do

not permit the containers to be stacked together or that reduce the effectiveness, stability and/or efficiency of the containers when they are stacked together. By way of example, one company that manufactures containers having different stacking patterns is ECS Composites, Inc. out of Grants Pass, Oregon.

[0004] A variety of containers with stackability patterns include, but are not necessarily limited to, the following containers described in U.S. Patent No. 6,457,599 to Apps *et al.*; U.S. Patent No. 6,237,758 to Hsu; U.S. Patent No. 6,186,345 to Robertson; U.S. Patent No. 6,085,467 to Packrall *et al.*; U.S. Patent No. 5,769,230 to Koefeld; U.S. Patent No. 5,203,494 to Blomfield; and U.S. Patent No. 4,655,360 to Juhanson.

#### SUMMARY OF THE INVENTION

[0005] Containers, such as transit containers, rack-mount containers, tote containers or other types of containers often include stacking patterns located on some portion of the container, for example the top and bottom surface or on the lid surfaces. Regardless, this stackability makes the containers more space efficient and easier to maneuver, especially in a field environment. As the containers evolve over time, sometimes it is either desired or necessary to modify the stacking pattern. However, users of the containers may still desire to stack containers having an older-style stacking pattern with containers having a newer-style stacking pattern, or vice-versa. Alternatively, the users may desire to stack containers that were simply designed with two different types of stacking patterns. Thus, in one embodiment, covers or wraps employing hybrid or complementary stacking patterns may be mounted, integrally formed with or otherwise attached to containers to permit the stacking of containers having different stacking patterns. By way of example, universal wraps (*i.e.*, upper and lower wraps) are used to construct a centerbody to permit the container to be stacked with another, different type of container.

[0006] In one example of the invention, a wrap system for a container includes a first wrap having first wrap protuberances and first wrap recessed regions extending from a first wrap surface of a first wrap body, the first wrap protuberances and first wrap recessed regions arranged in a desired stacking pattern; and a second wrap having second wrap protuberances and second wrap recessed regions extending from a second wrap surface of a second wrap body, the second wrap protuberances and second wrap recessed regions arranged to stackably cooperate with the desired stacking pattern.

[0007] In another example of the invention, a container includes a container centerbody; a top wrap coupled to the container side walls creating the aforementioned centerbody, the top wrap having top wrap protuberances and top wrap recessed regions extending from a top wrap surface of a top wrap body, the top wrap protuberances and top wrap recessed regions arranged in a desired stacking pattern; and a bottom wrap having bottom wrap protuberances and bottom wrap recessed regions extending from a bottom wrap surface of a bottom wrap body, the bottom wrap protuberances and bottom wrap recessed regions arranged to stackably cooperate with the desired stacking pattern.

#### **BRIEF DESCRIPTION OF THE DRAWINGS**

[0008] The preferred and alternative embodiments of the present invention are described in detail below with reference to the following drawings.

[0009] FIGURE 1 shows a perspective view of a container having universal wraps with complementary stacking patterns according to an embodiment of the present invention;

[0010] FIGURE 2 shows a perspective view of a top universal wrap having a first stacking pattern according to an embodiment of the present invention;

[0011] FIGURE 3 shows a top plan view of the top universal wrap of FIGURE 2;

[0012] FIGURE 4 shows a perspective view of a bottom universal wrap having a second stacking pattern according to an embodiment of the present invention;

[0013] FIGURE 5 shows a bottom plan view of the bottom universal wrap of FIGURE 4;

[0014] FIGURE 6 shows close-up view of a portion of the second stacking pattern of the bottom universal wrap of FIGURE 4; and

[0015] FIGURE 7 shows a top plan (interior) view of the bottom universal wrap of FIGURE 4.

#### **DETAILED DESCRIPTION OF THE PREFERRED EMBODIMENT**

[0016] In an example of the present invention, universal wraps (*i.e.*, upper and lower wraps) are used to create a container centerbody that permits the container to be stacked with another, different type of container. By way of example, the universal wraps include separate, but cooperating stacking patterns that allow a first generation container

to be stacked with a second or different generation container. Further, the universal wraps may advantageously eliminate the need for customers to replace the first generation containers with all second or different generation containers. For purposes of the description herein, the terms “first generation,” “second generation” and “different generation” are broadly used to describe modified containers indicating non-compatible stacking patterns regardless of whether the containers were produced at different times.

[0017] FIGURE 1 shows a container centerbody 100 having a side panel 102 coupled to a top universal wrap 104 and a bottom universal wrap 106. The side panel 102 may include handles 103 and latch mechanisms 105. In addition, the side panel 102 may be molded as a unitary component and manufactured from durable materials to include, but not limited to, various plastics, metals, fiber-reinforced composites or some combination of the above. In one embodiment, the wraps 104, 106 are bonded to the side panel 102. However, it is appreciated the wraps 104, 106 may be attached to the side panel 102 by other means, such as, but not limited to, an interference fit, a snap fit in which the wraps and side panels include cooperating snap portions, or fastening, for example with the wrap riveted to the centerbody.

[0018] FIGURES 2 and 3 show the top universal wrap 104 having a first stacking pattern 108 that may take the form of a plurality of spaced apart protuberances 110 extending from a surface 112. More specifically, the protuberances 110 may take the form of protrusions, projections, elements, features, bosses, ribs, *etc.* In addition, the protuberances 110 may take a variety of shapes, such as, but not limited to, quadrilaterals, polygons, circles, ellipses, *etc.* In one embodiment, the protuberances 110 are integrally molded with the surface 112 and side portions 114. Optionally, a portion 116 of the surface 112 may be reserved or made available for a label or other markings that may help identify the container 100 and/or the contents therein.

[0019] The stacking pattern 108 may be formed symmetrically with respect to axes 118, 120 (FIGURE 3). In the illustrated embodiment, the protuberances 110 are arranged in rows or columns 122, 124, 126 such that they nest within complementary portions of the bottom wrap 106, as described in greater detail below. Alternatively, the protuberances 110 may be arranged to nest within complementary portions of a bottom side stacking pattern of another container of the same or different generations.

[0020] FIGURES 4-6 show the bottom universal wrap 106 having a second stacking pattern 128 that may take the form of a plurality of spaced apart protuberances 130 extending from a surface 132. More specifically, the protuberances 130 may take the form of protrusions, projections, elements, features, bosses, ribs, *etc.* In addition, the protuberances 130 may take a variety of shapes, such as, but not limited to, quadrilaterals, polygons, circles, ellipses, plus-shapes, T-shapes, *etc.* In one embodiment, the protuberances 130 are integrally molded with the surface 132 and side portions 134. Optionally, a portion 136 of the surface 132 may be recessed or otherwise offset to nestingly engage with and/or provide clearance for previous generation protuberance patterns. As best shown in FIGURE 6, the recessed portions 136 include the selected regions 111, which are illustrated as footprints in dashed line format, where the footprints represent the outline of engaging protuberances. In the illustrated embodiment, the selected regions 111 receive the protuberances from row 122 of the top wrap 104 (FIGURE 2).

[0021] Referring to FIGURE 5, the protuberances 130 of the stacking pattern 128 may be formed symmetrically with respect to axes 138, 140. In addition, the recessed portions 136 may also be formed symmetrically with respect to the same axes 138, 140.

[0022] FIGURE 7 shows a top plan view of an interior surface 142 of the bottom wrap 106. As a means to streamline the manufacturing process, the bottom wrap 106 includes isolation features that correspond to an isolator foot print 144 extending from the interior surface 142. The isolation features 144 may be molded with the bottom wrap 106.

[0023] While the preferred embodiment of the invention has been illustrated and described, as noted above, many changes can be made without departing from the spirit and scope of the invention. Accordingly, the scope of the invention is not limited by the disclosure of the preferred embodiment. Instead, the invention should be determined entirely by reference to the claims that follow.



The embodiments of the invention in which an exclusive property or privilege is claimed are defined as follows:

1. A wrap system for a container comprising:
  - a first wrap having first wrap protuberances and first wrap recessed regions extending from a first wrap surface of a first wrap body, the first wrap protuberances and first wrap recessed regions arranged in a desired stacking pattern; and
  - a second wrap having second wrap protuberances and second wrap recessed regions extending from a second wrap surface of a second wrap body, the second wrap protuberances and second wrap recessed regions arranged to stackably cooperate with the desired stacking pattern.
2. The wrap system of claim 1, wherein the first wrap protuberances include quadrilateral-shaped members.
3. The wrap system of claim 1, wherein the first wrap recessed regions define at least a portion of the first wrap surface.
4. The wrap system of claim 1, wherein the first wrap recessed regions are located between respective first wrap protuberances.
5. The wrap system of claim 1, wherein the first wrap includes curved side members coupled to the first wrap body.
6. The wrap system of claim 5, wherein the first wrap body and the curved side members are permanently attachable to the side panels to create a centerbody of the container.
7. The wrap system of claim 1, wherein the second wrap protuberances include members selected from the group consisting of quadrilateral-shaped members, plus-shaped members, and T-shaped members.

8. The wrap system of claim 1, wherein the second wrap recessed regions define at least a portion of the second wrap surface.

9. The wrap system of claim 1, wherein the second wrap recessed regions are located between respective second wrap protuberances.

10. The wrap system of claim 1, wherein the second wrap includes curved side members coupled to the second wrap body.

11. The wrap system of claim 10, wherein the second wrap body and the curved side members are permanently attachable to side panels create a centerbody of the container.

12. A container comprising:

a container side panel;

a top wrap coupled to the container side panel, the top wrap having top wrap protuberances and top wrap recessed regions extending from a top wrap surface of a top wrap body, the top wrap protuberances and top wrap recessed regions arranged in a desired stacking pattern; and

a bottom wrap having bottom wrap protuberances and bottom wrap recessed regions extending from a bottom wrap surface of a bottom wrap body, the bottom wrap protuberances and bottom wrap recessed regions arranged to stackably cooperate with the desired stacking pattern.

13. The container of claim 12, wherein the top wrap protuberances include quadrilateral-shaped members.

14. The container of claim 12, wherein the top wrap recessed regions define at least a portion of the top wrap surface.

15. The container of claim 12, wherein the top wrap recessed regions are located between respective top wrap protuberances.

16. The container of claim 12, wherein the top wrap includes curved side members coupled to the top wrap body.

17. The container of claim 16, wherein the top wrap body and the curved side members are permanently attached to the side panel.

18. The container of claim 12, wherein the bottom wrap protuberances include members selected from the group consisting of quadrilateral-shaped members, plus-shaped members, and T-shaped members.

19. The container of claim 12, wherein the bottom wrap recessed regions define at least a portion of the bottom wrap surface.

20. The container of claim 12, wherein the bottom wrap recessed regions are located between respective bottom wrap protuberances.

21. The container of claim 12, wherein the bottom wrap includes curved side members coupled to the bottom wrap body.

22. The container of claim 21, wherein the bottom wrap body and the curved side members are permanently attached to the side panel.

1/6

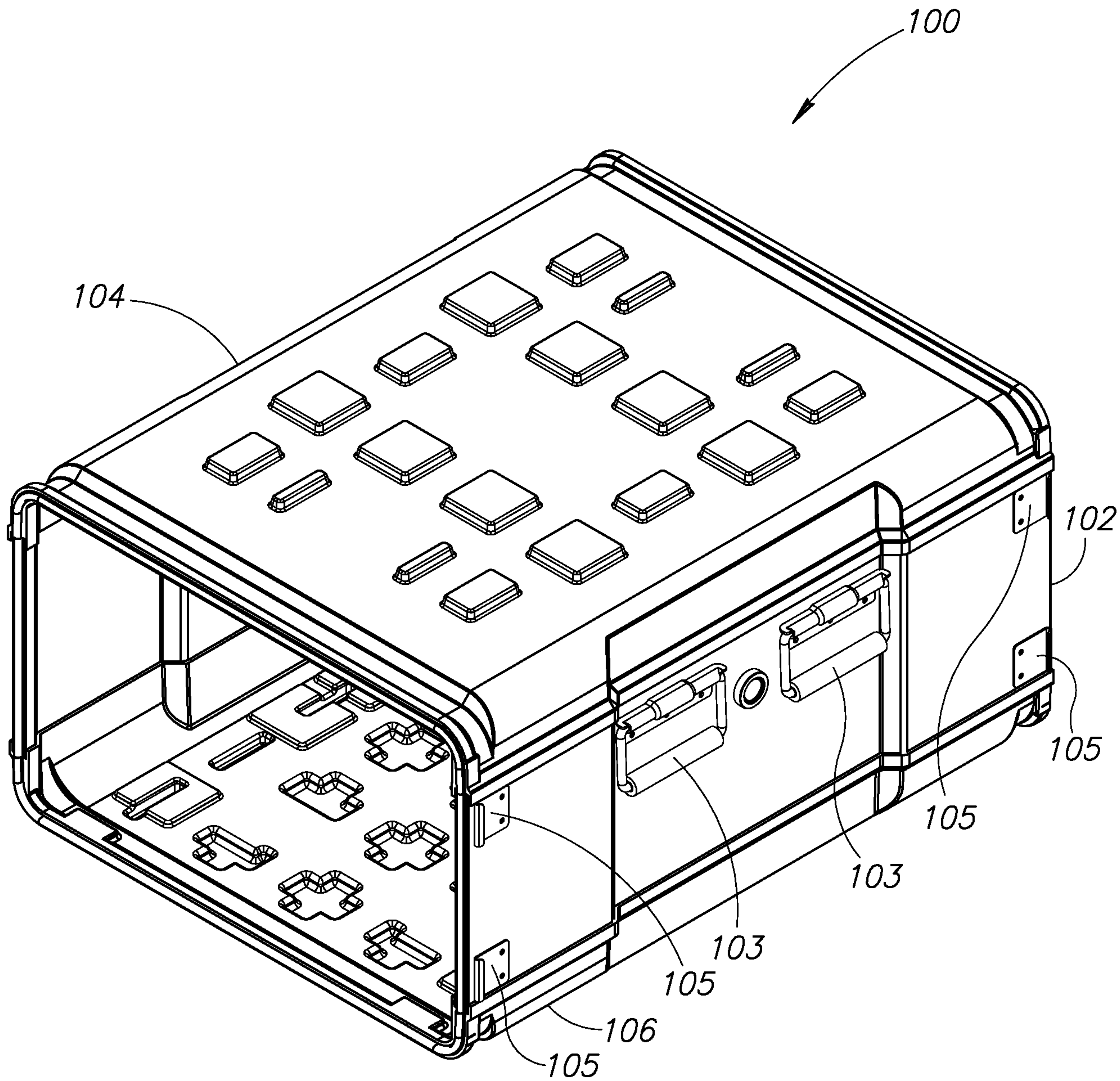

FIG.1

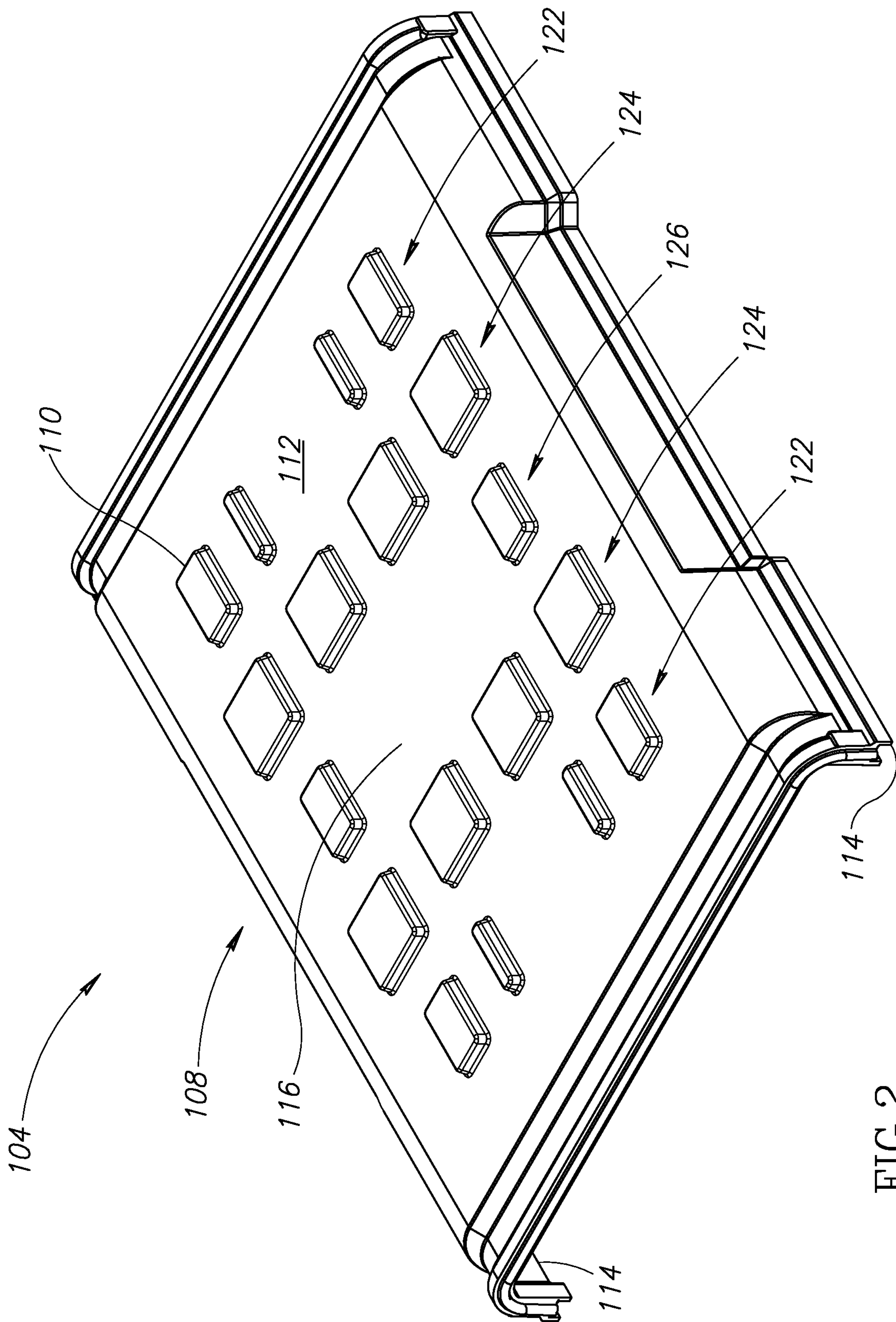

FIG. 2

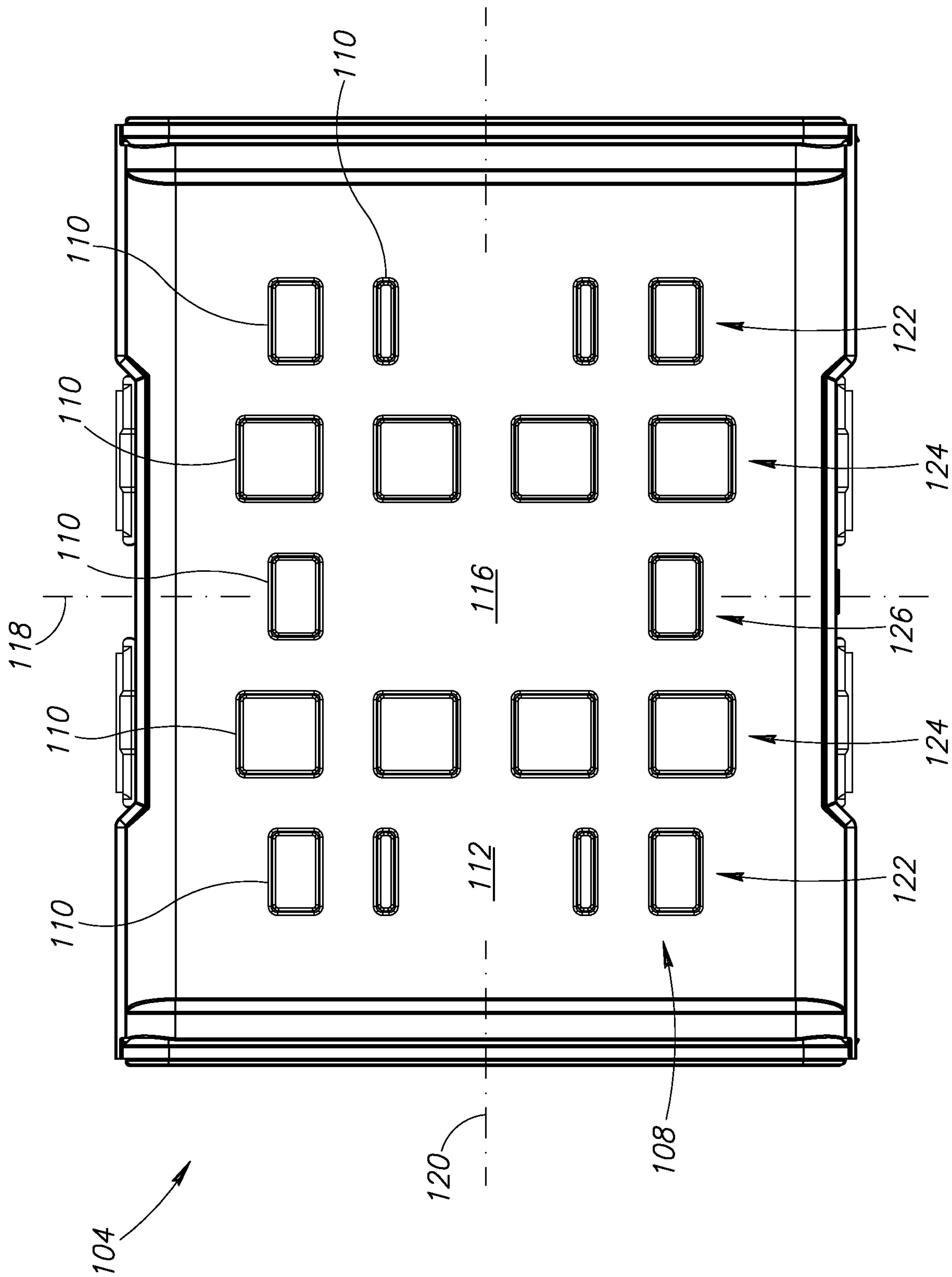

FIG. 3

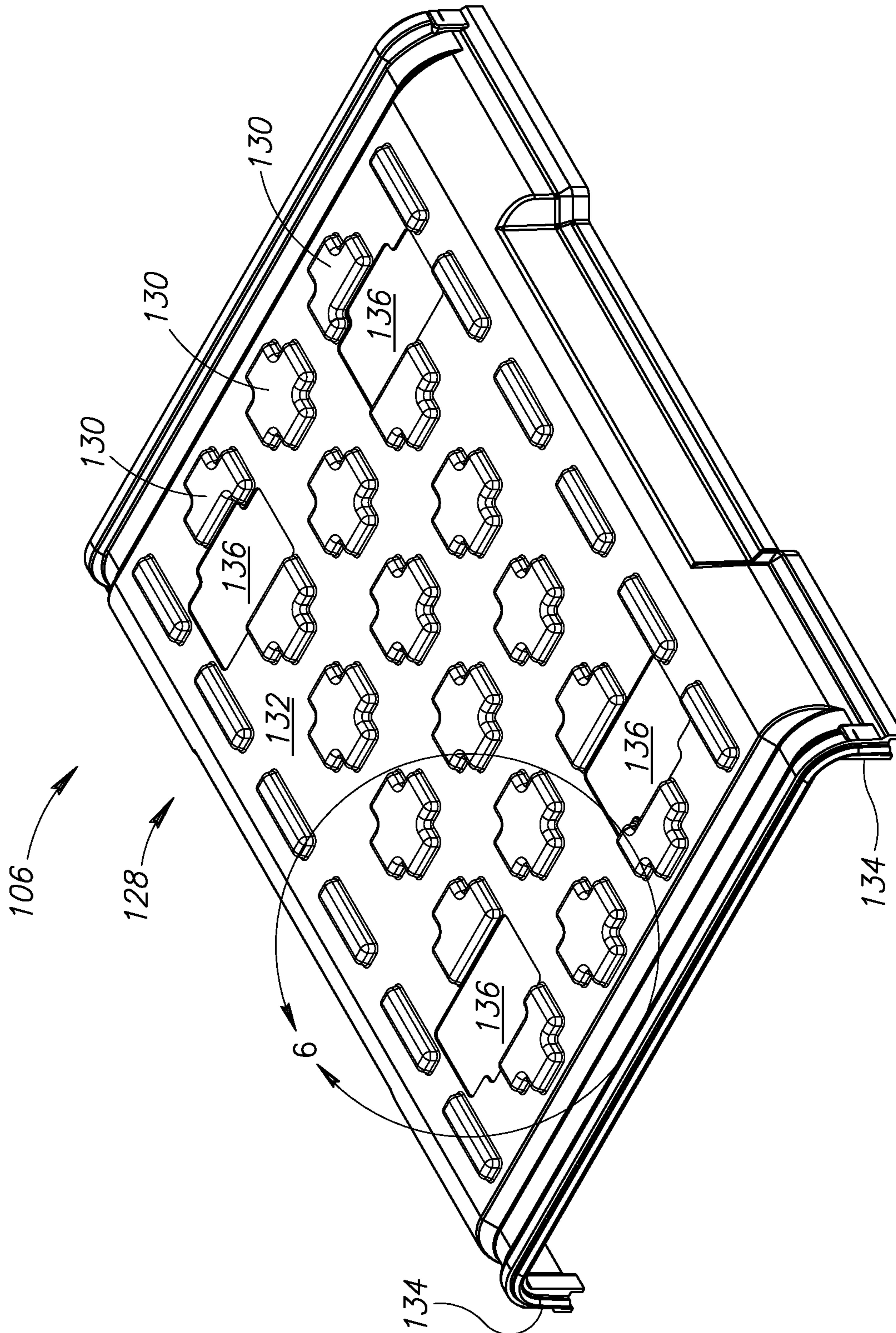
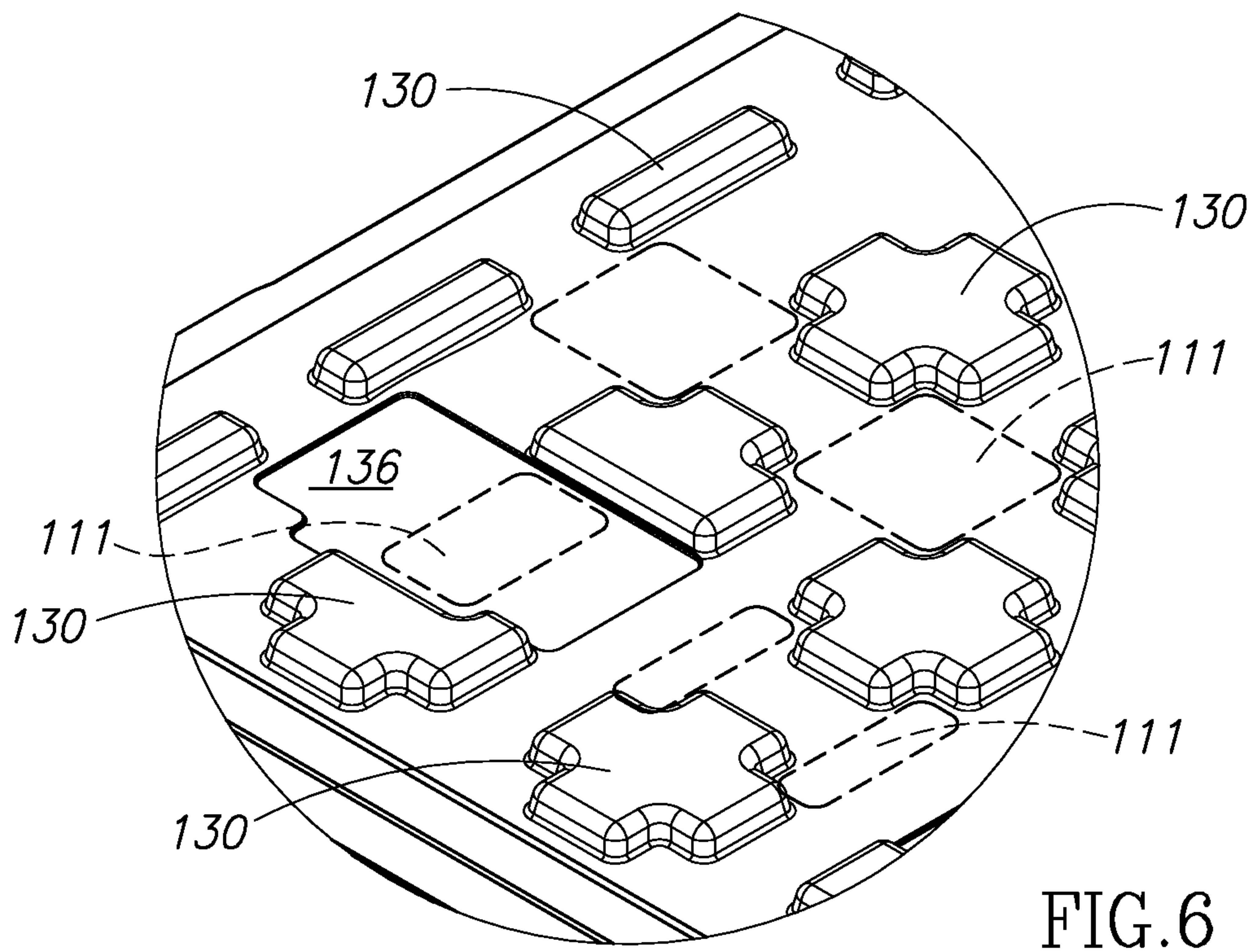
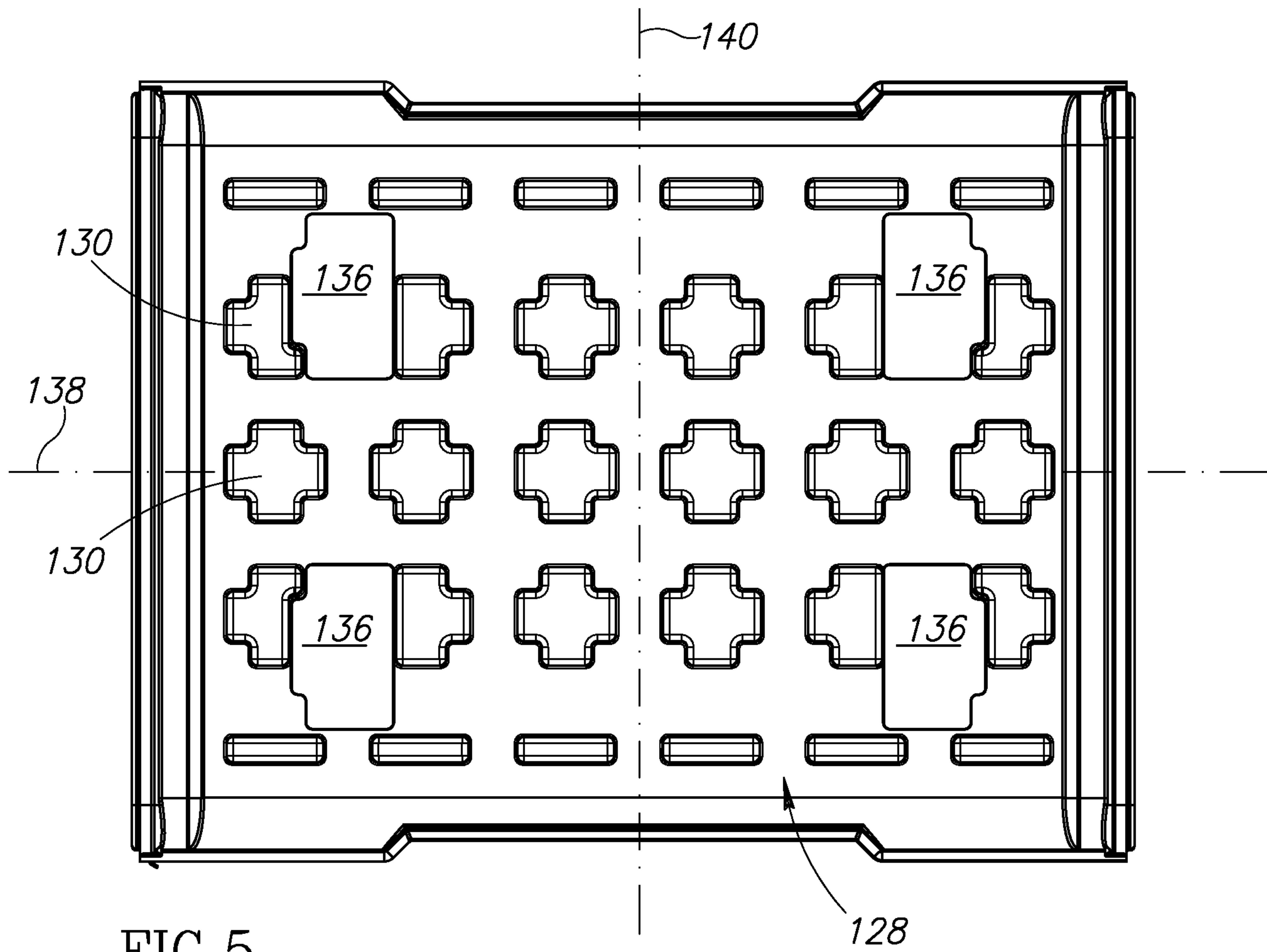
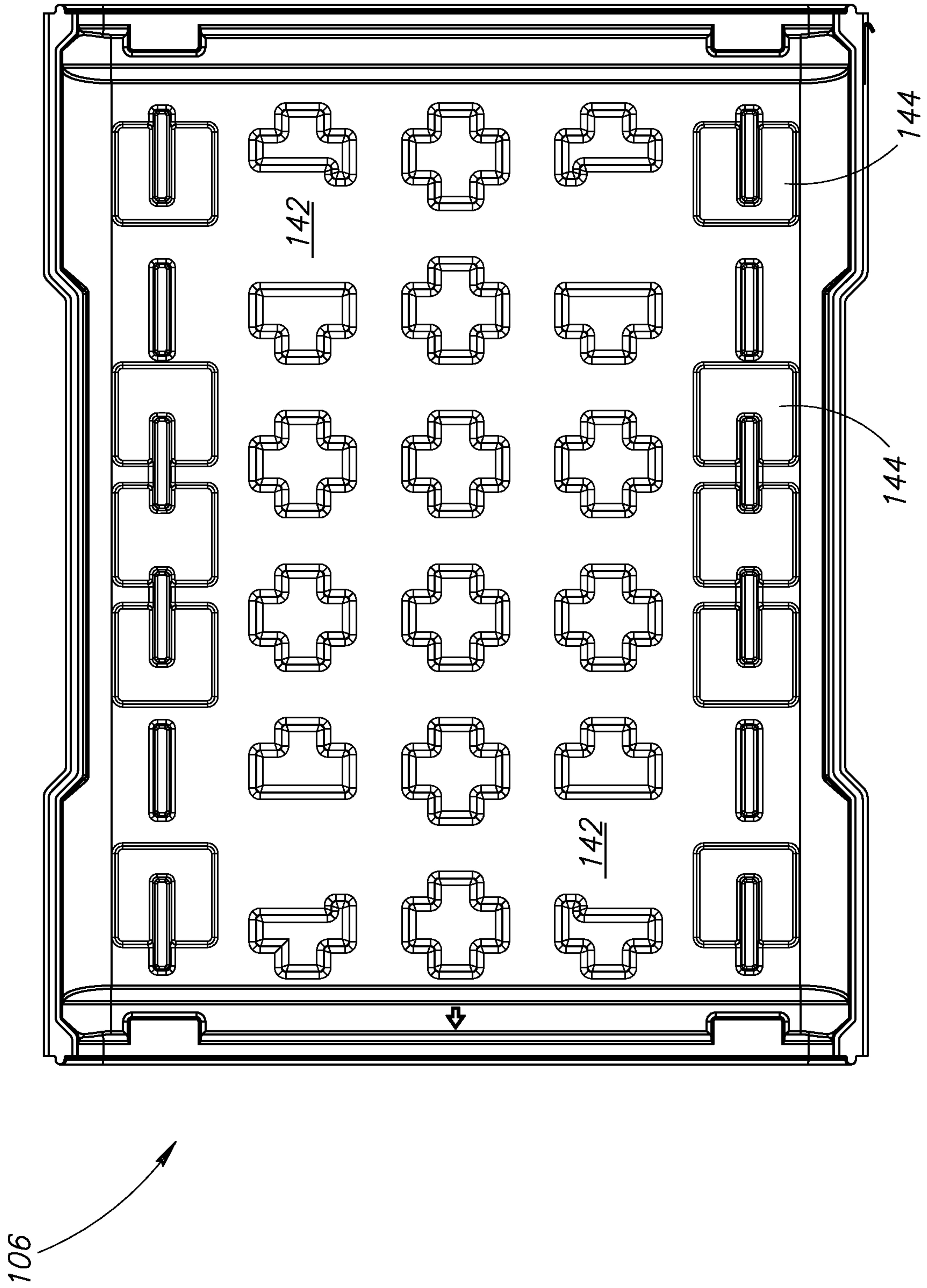

FIG. 4







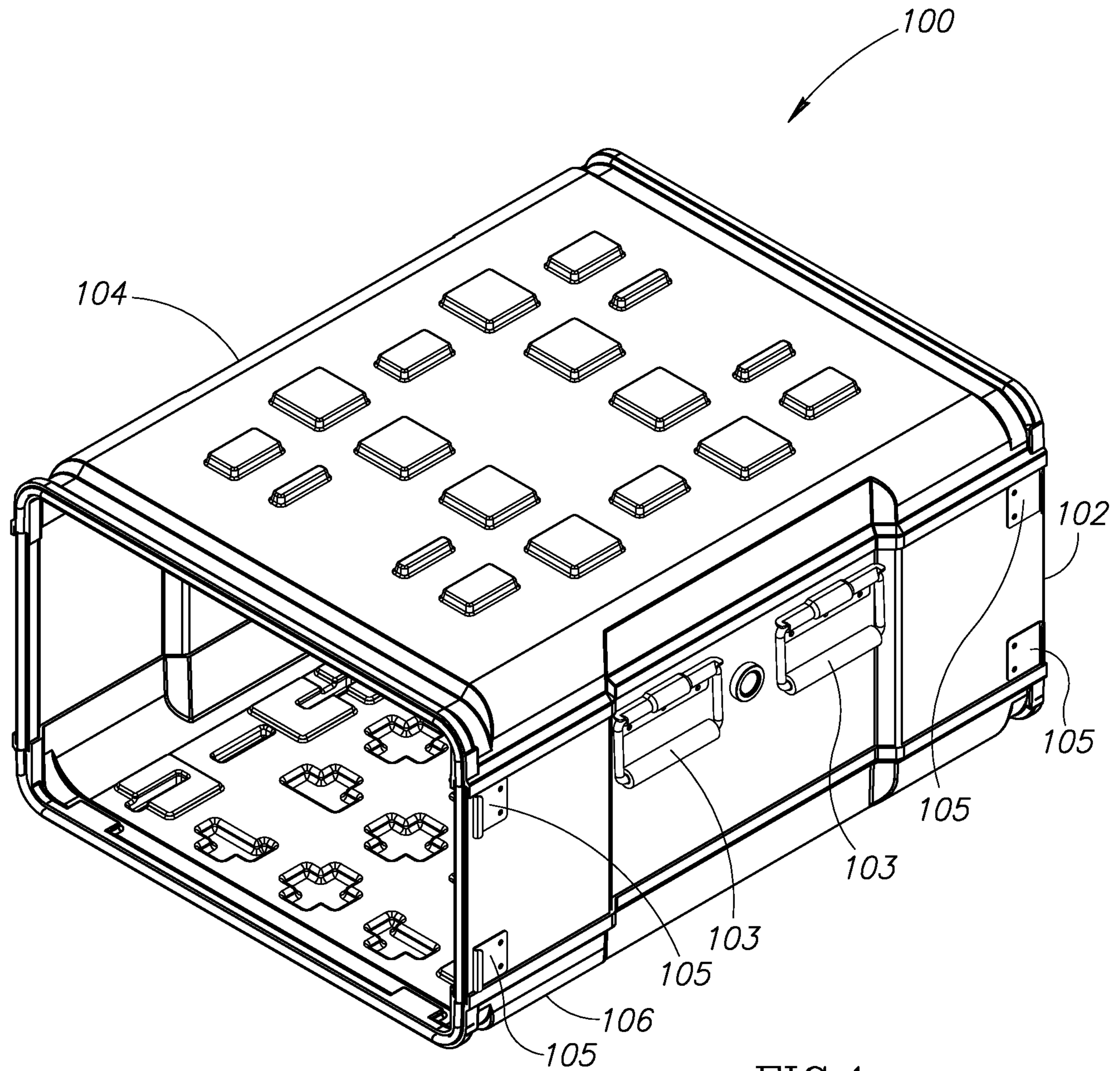

FIG.1