

(No Model.)

2 Sheets—Sheet 1.

X. MARGHERI.
POOL TABLE ATTACHMENT.

No. 366,123.

Patented July 5, 1887.

Fig. 1.

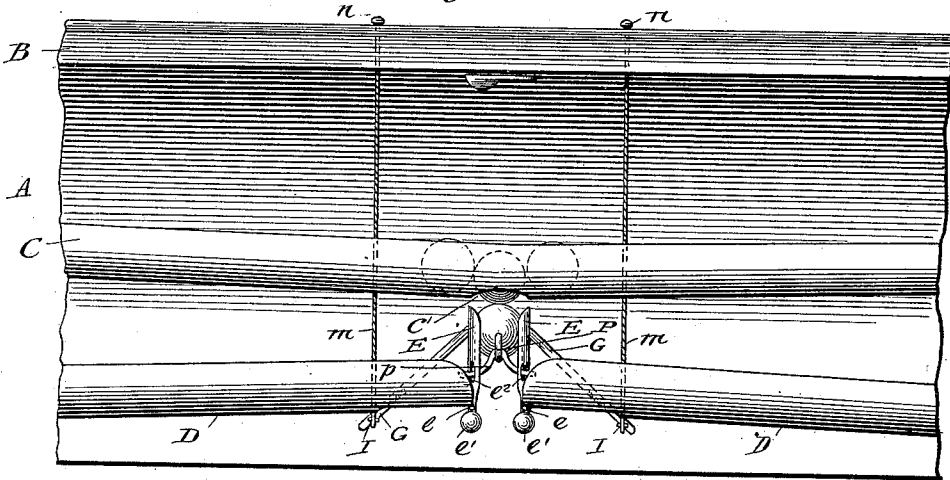

Fig. 2.

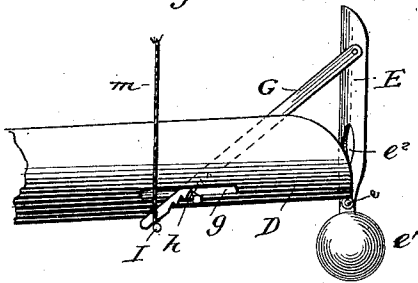
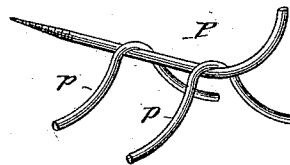

Fig. 3.



Witnesses.

J. Clark.
W. Sparus.

Inventor.

Xenophon Margheri
By *L. Edward Bacon*

Attorney.

(No Model.)

2 Sheets—Sheet 2.

X. MARGHERI.

POOL TABLE ATTACHMENT.

No. 366,123.

Patented July 5, 1887.

Fig. 4

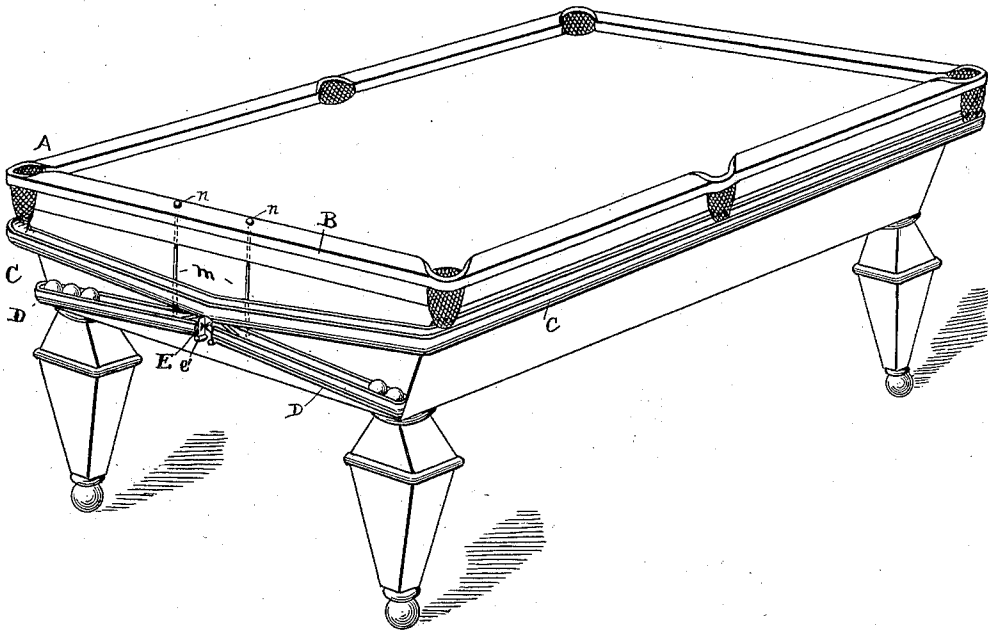
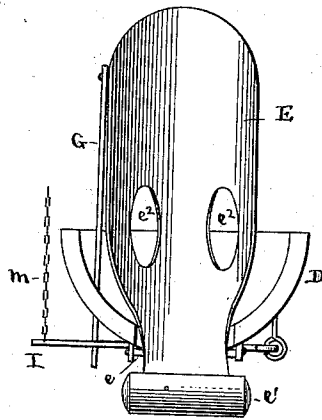

Fig. 5



Witnesses:

*Novis A. Clark
Chas. Rhodes,*

Inventor:

*Xenophon Margheri
By L. Seward Barry
his atty.*

UNITED STATES PATENT OFFICE.

XENOPHON MARGHIERI, OF SAN FRANCISCO, CALIFORNIA.

POOL-TABLE ATTACHMENT.

SPECIFICATION forming part of Letters Patent No. 366,123, dated July 5, 1887.

Application filed April 16, 1887. Serial No. 235,043. (No model.)

To all whom it may concern:

Be it known that I, XENOPHON MARGHIERI, a citizen of the United States, residing at San Francisco, in the county of San Francisco and State of California, have invented certain new and useful Improvements in Pool-Table Attachments; and I do hereby declare the following to be a full, clear, and exact description of the invention, such as will enable others skilled in the art to which it appertains to make and use the same.

My invention relates to an improvement in pool-table attachments; and it consists in the construction and combination of the parts, which will be more fully hereinafter described, and pointed out in the claims.

The object of my invention is to provide an attachment for pool-tables whereby the balls may be collected and deposited in the racks or receptacles designated for the use of the different players with but little trouble and without the necessity for handling or transporting the same away from the table. I attain this object by the device illustrated in the accompanying drawings, wherein like letters of reference indicate corresponding parts in the several views, and in which—

Figure 1 is an elevation of a portion of the front side of a pool-table, showing my attachment secured thereto. Fig. 2 is a rear view of an end of one of the ball-racks. Fig. 3 is a detail view of the rest and guide-arms. Fig. 4 is a perspective view of a pool-table, showing the arrangement of the inclined trough or ball-conductor. Fig. 5 is an end view of one of the racks.

In the drawings, A represents a portion of the front side of a pool-table. B designates the cushion-rail, which projects out from the side of the table in the usual manner. An inclined trough or ball-conductor, C, is rigidly secured to the sides of the table, in any suitable manner, directly beneath the cushion-rail B. This trough C is adapted to be extended along the entire length of both sides of the table beneath the pockets and incline gradually toward the center of the front side, at which point it is united. An aperture or hole, *c*, is made in the center of the bottom portion of the trough C at its lowest point or point of conjunction, it being of a sufficient size to admit of the passage of a single ball therethrough.

Situated directly beneath the trough C, on the front side of the table, are a series of oppositely-inclined racks, D D, they being secured to the table in any suitable manner. These racks D D extend downward toward the sides of the table, at which point they are terminated and blocked or capped in any suitable manner, so as to prevent the balls that are deposited therein from rolling out. The upper ends of the racks D D are separated a short distance from each other, and are bifurcated or cut out in their center portions. A series of concavo-convex arms or wings, E E, are mounted in the bifurcated ends of the racks D D, having their concave faces facing each other, they being journaled on suitable rods, *ee*, which have bearing in the sides of the racks D D. These arms E E are made so as to have their concave sides conform to the contour of the balls and their convex sides to conform to the inner curvature of the racks D D. Their lower portions are somewhat reduced in width, to which portions are rigidly secured weights *e' e'*, which overcome the weight of the concavo-convex portions, and thereby retain the arms in a vertical position. Elongated openings *e² e²* are made in the sides of the arms E E.

To prevent the arms E E from being forced down, brace-rods G G are pivotally connected to their sides, and extend downward at an incline into slots *g g*, made in the sides of the racks D D, and protrude somewhat below the said racks. The under sides of the lower end portions of arms E E have a series of serrations or teeth cut therein, which are adapted to be brought in contact with the sharp edges of catches *h h*, which are secured in the sides of the racks and extend transversely through the slots *g g*. The teeth on braces G G, being brought in contact with said catches, prevent the said braces from being forced down, thereby retaining the arms in their vertical position when pressure is placed on their upper ends. To release the braces G G from the catches *h h* by disengaging the teeth, levers I I, constructed of metal in a cylindrical form, are placed beneath the racks D D, having their outer ends loosely secured to suitable eyes or loops attached to the racks, and extend across the bottom of the racks directly under the protruding portion of the braces G G. Their inner ends are secured to chains or cords *m m*,

which extend up past the trough C and through the cushion-rail B, at which point they are provided with buttons *n n*, which are retained on the upper surface of said rail. The chains *m* 5 *m* are made of sufficient length to allow the ends of levers I I to fall slightly below the protruding portions of braces G G.

Situated between the arms E E and directly beneath hole *c* in the trough C, at a distance 10 equal to the diameter of a ball, is a rest or rod, P, having its inner end secured to the table and extending out past the said arms E E. This rest is made of small diameter and with smooth sides, thus allowing a ball to immediately roll off therefrom when released. Guides 15 *p p*, constructed of U-shaped strips of metal, are rigidly secured to the upper side of rest P, at a position directly between the arms E E. Their outer portions are extended downward and bent slightly upward, and are inserted in the openings *e² e³* in the arms E E, their ends extending beyond the upper ends of the racks D D. These guides *p p* are so placed on the rest as to leave a space between 20 somewhat narrower than the diameter of a ball, and, owing to their being placed on the top of the rest P, they act as blocks to prevent the ball from rolling off from the ends of the said rest. It will thus be seen that when the 30 balls are placed in the trough C they will immediately roll down the same until they reach the hole *c* at the front of the table, and into which the first immediately falls and thence onto the rest P and guides *p p*, and is there retained and closely held by the arms E E, thus blocking hole *c* and preventing the other balls from going through. When the balls belonging to the player having just finished have been collected in the trough C above the racks 40 D D, the button *n* is lifted up, thereby drawing up the chain *m*, which in turn lifts the lever I and brings it in contact with the protruding end of brace G, which is lifted up off from the catch *h*, thus releasing the arm E, which will be immediately forced down by the weight of the ball, which rolls down the U-shaped guide *p p*. The arm E being made to conform to the curvature of the inside of the rack D, will be forced down onto the same, and owing to the inclination of said rack the ball will immediately 50 pass on to the end of the rack. As soon as the first ball is released the remaining balls will immediately fall into the hole *c* onto the rest P and guides *p p*, and be conducted into the rack, the rapidity of the movement of the balls preventing the arm E from assuming its vertical position. When the balls have all been discharged into the rack, the arm immediately assumes a vertical position by virtue of 60 the weight *e'* on its lower end, and the lever I being dropped, the brace G is again brought in contact with the catch *h*, which engages with the teeth on the under side of the brace and thus holds the arm E rigid, as before. 65 When the second player has completed his play, the same operation is performed with the opposite arm, thus keeping all of the balls be-

longing to the one player separate from those of the other. When the balls are to be used again, they are taken from the racks by the use 70 of the hands and placed on the table ready for use.

I am aware that pool-tables have been constructed with troughs or conductors for the balls placed on their sides. 75

Having thus described my invention, what I claim as new, and wish to secure by Letters Patent, is—

1. A pool-table having a trough or conductor for the balls attached to the sides thereof, which has an opening in its lowermost bottom portion, and a series of inclined racks situated beneath said trough, into which the balls are adapted to be discharged. 80

2. A pool-table having an inclined ball-conductor or trough attached thereto, having an opening therein, a series of inclined racks attached to the table directly beneath said trough, ball retaining and releasing devices mounted on the ends of said racks, a rest secured to said table, and a means for operating said devices, substantially as described. 85

3. A pool-table having attached thereto an inclined trough or ball-conductor having a hole therein, a series of inclined racks attached to said table beneath said trough, a rest having guides attached thereto secured to said table, and means for retaining and releasing the ball, substantially as described. 90

4. A pool-table having an inclined trough or ball-conductor attached thereto, which has a circular hole in its lowermost portion, a series of oppositely-inclined racks or ball-receptacles situated beneath said trough and attached to said table, weighted arms mounted on the ends of said racks, a rest secured to said table directly beneath said hole, and means for releasing the ball from said rest, substantially as described. 95

5. In a pool-table attachment, the combination of a series of inclined racks having movable weighted concavo-convex arms mounted thereon, braces attached to said arms adapted to retain the same in an elevated position, a lever having a chain attached thereto, whereby said lever is operated, and a rest for the balls situated between said arms, substantially as described. 100

6. In a pool-table attachment, the combination of the inclined racks D D, having weighted arms E E secured thereon, braces G G, secured to said arms, levers I I, attached to said racks and adapted to release said braces, chains *m m*, attached to said levers and extending up to the top of said table, a rest, P, situated between said arms, having guides *p p* secured thereto, and a trough, substantially as described. 105

In testimony whereof I affix my signature in presence of two witnesses.

XENOPHON MARGHERI.

Witnesses:

J. M. PIERCE,

ERNEST J. MOTT.