

L. ROTH.
MECHANICAL STOKER.
APPLICATION FILED JULY 30, 1904.

2 SHEETS—SHEET 1.

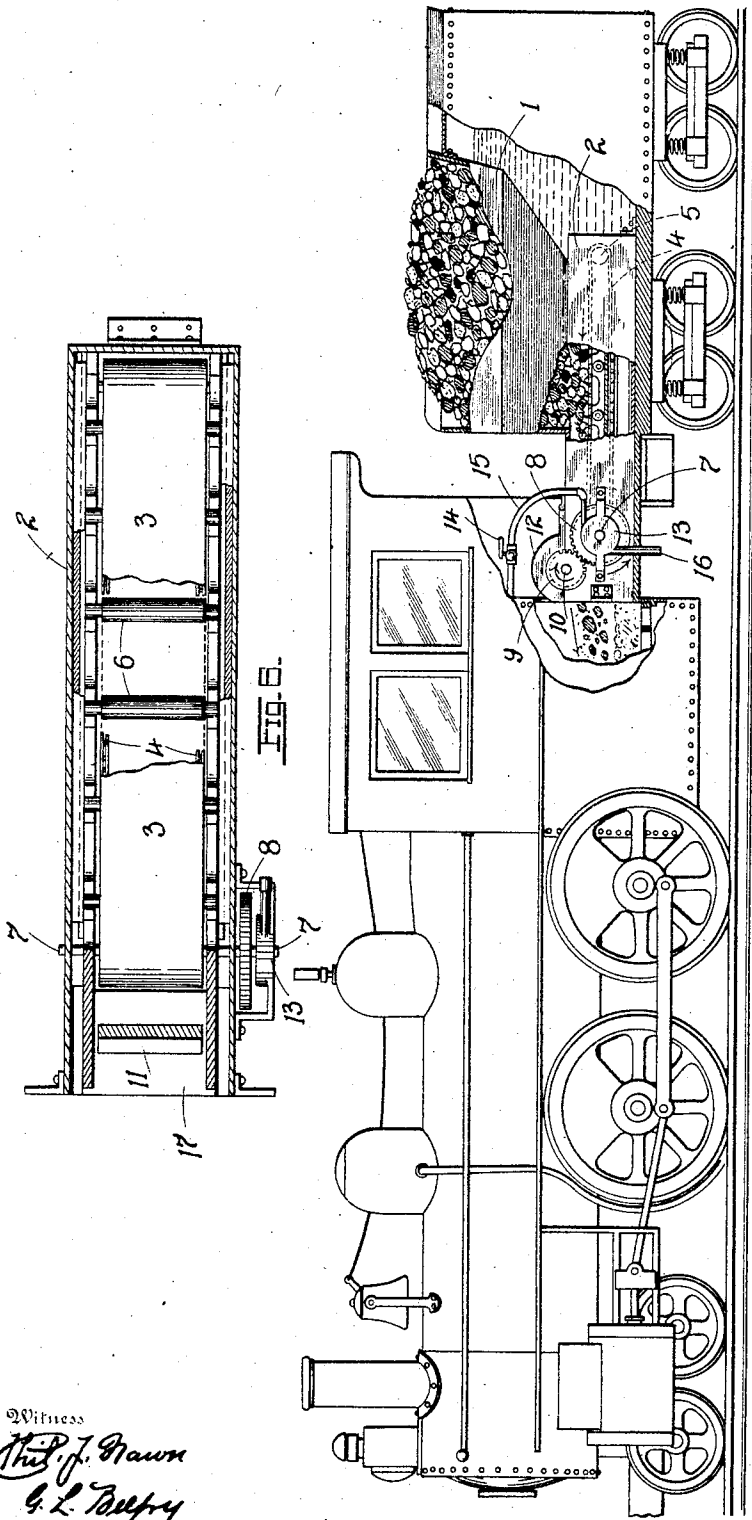

Witness
Thos. J. Brown
G. L. Deery

FIG. 1.

Inventor
Ludwig Roth
by
Ernst Hansen
Attorney

L. ROTH.
MECHANICAL STOKER.
APPLICATION FILED JULY 30, 1904.

2 SHEETS—SHEET 2.

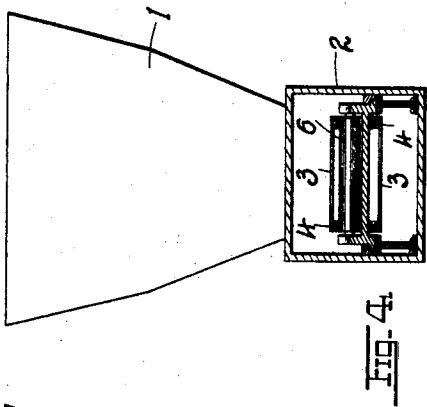

FIG. 4.

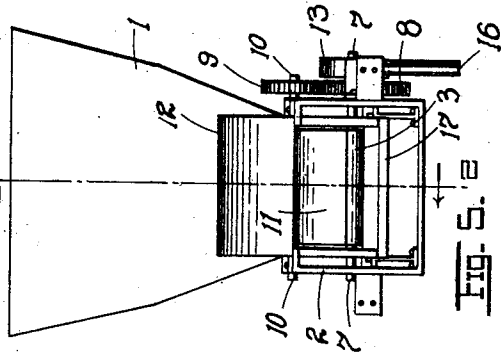

FIG. 5.

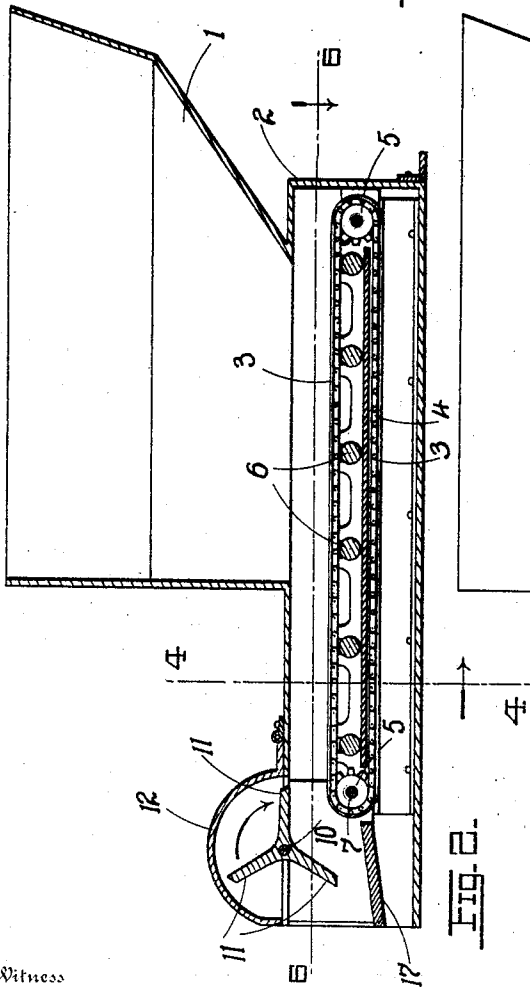

FIG. 6.

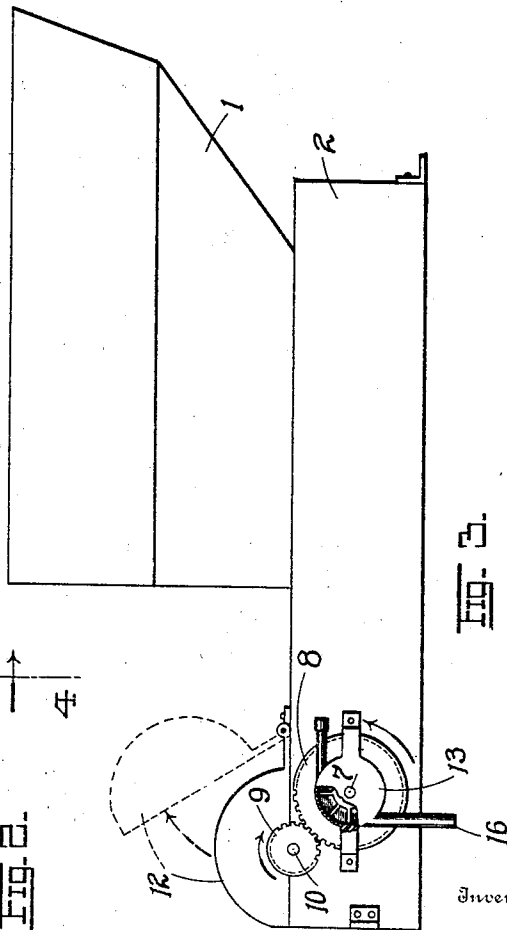

FIG. 7.

Witness
Chas. P. Mann
G. L. Budy

Inventor
Ludwig Roth
 by
Emil Storer
 Attorney

UNITED STATES PATENT OFFICE.

LUDWIG ROTH, OF ST. LOUIS, MISSOURI.

MECHANICAL STOKER.

SPECIFICATION forming part of Letters Patent No. 785,835, dated March 28, 1905.

Application filed July 30, 1904. Serial No. 218,803.

To all whom it may concern:

Be it known that I, LUDWIG ROTH, a citizen of the United States, residing at St. Louis, State of Missouri, have invented certain new and useful Improvements in Mechanical Stokers, of which the following is a full, clear, and exact description, reference being had to the accompanying drawings, forming a part hereof.

My invention has relation to improvements in mechanical stokers; and it consists in the novel construction and arrangement of parts more fully set forth in the specification, and pointed out in the claims.

In the drawings, Figure 1 is a side elevation of an engine and its tender with parts broken away, showing my invention applied thereto. Fig. 2 is a vertical longitudinal section on line 2 2 of Fig. 5, the conveyer being in elevation. Fig. 3 is a side elevation of the apparatus with parts broken away. Fig. 4 is a vertical transverse section on line 4 4 of Fig. 2. Fig. 5 is a front elevation thereof, and Fig. 6 is a horizontal section on line 6 6 of Fig. 2 with parts broken away.

The object of my invention is to construct a stoker which can be set in motion at any time by the driving-power of the steam of the boiler, the stoker being so constructed as to forcibly inject the fuel into the fire-box of such boiler, as will hereinafter more fully appear from a detailed description of the invention, which is as follows:

Referring to the drawings, 1 represents a suitable hopper in which the coal is initially stored, said hopper having, preferably, inclined walls, as shown, and surmounting an elongated casing 2, within which is confined an endless-belt conveyer 3, said conveyer being carried by the sprocket-chains 4, passing over sprocket-wheels 5 5. At intervals the upper flap of the conveyer is supported on rollers 6. The shaft 7 of the forward sprockets 5 carries a gear-wheel 8, which meshes with a pinion 9 on a shaft 10, the latter having disposed thereon a series of radial blades 11, incased in a shield or hood 12, hinged to the casing 2. The shaft 7 likewise forms the shaft of the steam rotary engine 13, which can be set in motion by the engineer at any time by opening the valve 14 in the steam-supply

pipe 15, the spent steam escaping through the exhaust-pipe 16.

To operate the stoker, the rotary engine is set in motion, as shown by the arrow in Fig. 3, the pinion 9 being rotated in the direction shown by the arrow in said figure, the blades 11 revolving, as shown in Fig. 2. The parts being thus set into motion, the conveyer travels in the direction indicated by the arrows in Fig. 1, the coal being gradually fed forward on the conveyer until it reaches the end thereof, when it encounters the rapidly-revolving blades 11, which engage the coal, sweeping it across the inclined platform or plate 17, Fig. 2, and forcibly injecting it into the fire-box of the boiler, as seen in Fig. 1. The rapid rotation imparted to the blades 11 is very essential, for then the deposit of the coals into the innermost portions of the fire-box is assured. The platform 17 of course insures proper direction for the final injection of the fuel into the fire-box.

It is of course apparent that I may depart from the details of construction here shown without affecting the nature or spirit of my invention.

Having described my invention, what I claim is—

1. A mechanical stoker comprising a casing, means for feeding coal thereto, a traveling conveyer in the casing for advancing the coal fed into the casing toward the fire-box of the boiler, a revolving blade arranged to remove the coal from the conveyer, located at a point between the fire-box and the discharge end of the conveyer, and having a peripheral velocity in excess of the belt conveyer whereby the coal is forcibly injected into the furnace, substantially as set forth.

2. A mechanical stoker comprising a hopper, a casing at the base thereof, a traveling belt conveyer for advancing the coal toward the fire-box of the boiler, a revolving series of blades located at the forward end of the conveyer and between the latter and the fire-box and arranged to remove the coal from the conveyer, said blades having a peripheral velocity in excess of the belt conveyer whereby the coal is forcibly injected into the furnace, substantially as set forth.

3. A mechanical stoker comprising a hopper, a casing at the base thereof, a traveling belt conveyer in said casing, a motor for imparting motion to the conveyer, a series of
5 revolving blades disposed about a shaft at one end of the conveyer for removing the coal therefrom and injecting it into the fire-box, and suitable speed - multiplying gear interposed between said motor and the shaft of the
10 blades for rotating the latter at an increased speed over the conveyer, substantially as set forth.

4. A mechanical stoker comprising a hopper, a casing at the base thereof, a traveling
15 belt conveyer in said casing, a motor for imparting motion to the conveyer, a gear-wheel

on the motor-shaft, a series of revolving blades located at the forward end of the conveyer and arranged to remove the coal therefrom, a speed-multiplying pinion on the shaft of the
20 blades meshing with the aforesaid gear-wheel, a platform for guiding the coal impelled by the blades, the latter having a peripheral velocity in excess of the belt conveyer, whereby the coal is forcibly injected into the furnace,
25 substantially as set forth.

In testimony whereof I affix my signature in presence of two witnesses.

LUDWIG ROTH.

Witnesses:

EMIL STAREK,
G. L. BFLFRY.