



- (51) International Patent Classification:
A61M 25/06 (2006.01)
- (21) International Application Number:
PCT/IB2012/053820
- (22) International Filing Date:
26 July 2012 (26.07.2012)
- (25) Filing Language: English
- (26) Publication Language: English
- (30) Priority Data:
2109/DEL/2011 26 July 2011 (26.07.2011) IN
- (71) Applicant (for all designated States except US): **POLY MEDICURE LIMITED** [IN/IN]; Plot No. 105, Sector 59, HSIIDC Industrial Area, Faridabad, Haryana 121004 (IN).
- (72) Inventor; and
- (75) Inventor/Applicant (for US only): **BAID, Rishi** [IN/IN]; W - 169, Greater Kailash - II, New Delhi 110048 (IN).
- (74) Agents: **PRATAP, Prabhakar Mani** et al.; No. 704, The Castle, 36 - A, Sector 56, Gurgaon, Haryana 122009 (IN).

- (81) Designated States (unless otherwise indicated, for every kind of national protection available): AE, AG, AL, AM, AO, AT, AU, AZ, BA, BB, BG, BH, BN, BR, BW, BY, BZ, CA, CH, CL, CN, CO, CR, CU, CZ, DE, DK, DM, DO, DZ, EC, EE, EG, ES, FI, GB, GD, GE, GH, GM, GT, HN, HR, HU, ID, IL, IN, IS, JP, KE, KG, KM, KN, KP, KR, KZ, LA, LC, LK, LR, LS, LT, LU, LY, MA, MD, ME, MG, MK, MN, MW, MX, MY, MZ, NA, NG, NI, NO, NZ, OM, PE, PG, PH, PL, PT, QA, RO, RS, RU, RW, SC, SD, SE, SG, SK, SL, SM, ST, SV, SY, TH, TJ, TM, TN, TR, TT, TZ, UA, UG, US, UZ, VC, VN, ZA, ZM, ZW.
- (84) Designated States (unless otherwise indicated, for every kind of regional protection available): ARIPO (BW, GH, GM, KE, LR, LS, MW, MZ, NA, RW, SD, SL, SZ, TZ, UG, ZM, ZW), Eurasian (AM, AZ, BY, KG, KZ, RU, TJ, TM), European (AL, AT, BE, BG, CH, CY, CZ, DE, DK, EE, ES, FI, FR, GB, GR, HR, HU, IE, IS, IT, LT, LU, LV, MC, MK, MT, NL, NO, PL, PT, RO, RS, SE, SI, SK, SM, TR), OAPI (BF, BJ, CF, CG, CI, CM, GA, GN, GQ, GW, ML, MR, NE, SN, TD, TG).

[Continued on next page]

(54) Title: NEEDLE TIP PROTECTOR ASSEMBLY FOR SAFETY IV CATHETER ASSEMBLY

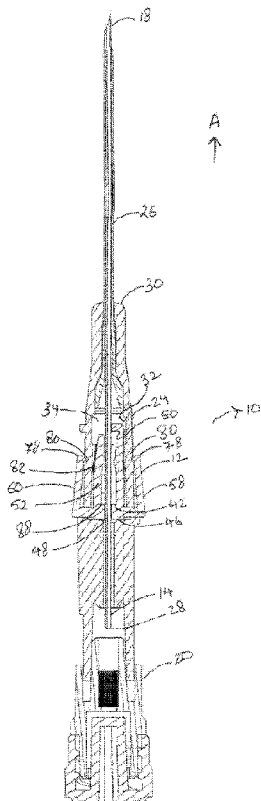

Fig. 1B

(57) Abstract: The invention relates to a needle tip guard for a safety IV catheter assembly 10 comprising a catheter tube 26 having a distal end 30 and a proximal end 28; a catheter hub 24 having a distal end 30 and a proximal end 28, wherein the distal end 30 is joined to the said catheter tube 26 and the proximal end 28 defines a chamber 34; a needle 14 extending through the catheter hub 24 and the catheter tube 26 having opposite proximal 28 and distal 30 ends defining an axial direction A, wherein the proximal end 28 is joined to the needle hub 20 and the distal end 30 forms a sharp tip 18 and a change in profile 36 is provided between the proximal 28 and distal 30 ends of the needle 14; and a tip protector assembly 12 movably arranged in between the catheter hub 24 and needle hub 20 on the needle 14 such that the tip protector assembly 12 is retained partially and/or completely in the chamber 34 of the catheter hub 24 and wherein the tip protector assembly is configured to entrap the needle tip 18 upon withdrawal of the needle 14 from the catheter hub 24.



Declarations under Rule 4.17:

- *as to the identity of the inventor (Rule 4.17(i))*
- *as to applicant's entitlement to apply for and be granted a patent (Rule 4.17(ii))*
- *as to the applicant's entitlement to claim the priority of the earlier application (Rule 4.17(iii))*
- *of inventorship (Rule 4.17(iv))*

Published:

- *with international search report (Art. 21(3))*
- *before the expiration of the time limit for amending the claims and to be republished in the event of receipt of amendments (Rule 48.2(h))*

Description

Title of Invention: NEEDLE TIP PROTECTOR ASSEMBLY FOR SAFETY IV CATHETER ASSEMBLY

[1] **CROSS-REFERENCE TO THE RELATED APPLICATION**

[2] This application claims priority from Indian Patent Application No. 2109/DEL/2011 dated July 26, 2011, the entire disclosure of which is incorporated herein by reference.

[3] **FIELD OF THE INVENTION**

[4] The present invention relates to a medical device such as, for example a safety intravenous (IV) catheter assembly. More particularly, the invention relates to a needle tip protector assembly for safety IV catheter assembly with improved safety means and mechanism that automatically covers the sharp tip of the needle after withdrawal of the needle from the catheter and catheter hub.

[5] **BACKGROUND OF THE INVENTION**

[6] An intravenous (IV) catheter assembly of this kind is generally known and, for example, used to administer fluid and/or medicine to a patient or to take blood from a patient.

[7] Accidental needle sticks/pricks have become a major concern to health-care worker. It is well known and understood by healthcare workers that sharp surgical instruments, such as catheter needles, have a significant potential for harm to healthcare workers. During surgery, handling of these sharp instruments can lead to accidental sticks or puncture wounds exposing the healthcare worker to the infections such as AIDS and hepatitis. The chances of needle stick are increased during an emergency with several aspects require to be handled. Likewise, during disposal, an exposed needle point may be and usually is a threat to the medical waste handler.

[8] Various safety IV catheter assemblies have been developed to automatically cover and shield the needle tip after its withdrawal from the patient. These assemblies have taken a number of embodiments and have various degrees of elaboration. However, the safety mechanisms implemented in these assemblies increase costs of manufacture substantially and may malfunction, especially in a fluid-filled environment where it may stick or slip. Some of the known needle protecting systems requires multiple parts, which drives up the manufacturing cost for a disposable unit. The cost-benefit requirements of the medical industry call for an inexpensive needle protecting system which is disposable along with the needle. Furthermore, the system must be quick and easy to use as to present as little in position as possible to the administration and function of the safety IV catheter assembly.

[9] Moreover, some IV catheter assemblies with the needle guard that have been

developed sometimes fail to prevent occurrence of unintended needle stick injuries. Generally, in such assemblies a needle safety device or needle guard is arranged completely in a chamber defined by the catheter hub. In order to ensure correct protective function of the needle guard, it is necessary that the needle guard is secured steadily in its ready position while being secured inside in the catheter hub. However, such assemblies suffers from the problem of premature release of the needle guard from the catheter hub under retracting forces applied on the needle while disengaging the needle hub from the catheter hub. In such a situation, the risk of accidental needle stick injury is a real threat to the users/practitioners. Moreover, such pre-mature release and un-steadiness of the needle guard in the catheter hub affects its correct and effective function protecting the tip of the needle.

[10] There is need to protect the healthcare workers from accidental needle pricks. Thus, there is a constant need for having a tip protector assembly for a safety IV catheter assembly with improved safety means that automatically covers the sharp tip of the needle after withdrawal of the needle from the catheter and catheter hub preventing accidental pricks and sticks and which is easy and inexpensive to manufacture.

[11] **OBJECTS OF THE INVENTION**

[12] Therefore, it is an object of the invention to provide a protective system which is simple and dependable in its deployment, inexpensive to manufacture, expedient in its operation and effective in protecting a needle tip, and which ensures correct functioning even after longer shelf life.

[13] Other objects and advantages of the present invention can be ascertained from the following disclosure.

[14] **SUMMARY OF THE INVENTION**

[15] The present invention relates to a needle tip protector assembly for use in a safety intravenous (IV) catheter assembly with improved safety means and mechanism that automatically covers the sharp tip of the needle after withdrawal of the needle from the catheter tube and catheter hub.

[16] According to one embodiment, a safety IV catheter assembly is provided comprising: a catheter tube having a distal end and a proximal end; a catheter hub having a distal end and a proximal end, wherein the distal end is joined to the said catheter tube and the proximal end defines a chamber; a needle extending through the catheter hub and the catheter tube having opposite proximal and distal ends defining an axial direction, wherein the proximal end is joined to the needle hub and the distal end forms a sharp tip and a change in profile is provided between the proximal and distal ends of the needle; a tip protector assembly movably arranged in between the catheter hub and needle hub on the needle such that the tip protector assembly is retained partially and/or completely in the chamber of the catheter hub including: a base portion in the region

of its proximal end having a needle passage with a through bore extending in an axial direction from a proximal side of the base portion to a distal side of the base portion; first and second arms extending substantially in the axial direction from the distal side of the base portion; at least one tension creating element surrounding partially and/or completely the said first and second arms in a region proximal to the distal ends thereof; at least one stopper element arranged in the base portion having an axial bore with a dimension adapted to the principal outer profile of the said needle; at least one pair of first and second retaining arms connected to the base portion by transverse segments extending therefrom in a direction opposing each other; and one or more first retaining means in an arrangement engaging with the one or more second retaining means provided on the inner and/or outer walls of the catheter hub for retaining the tip protector assembly in the chamber as long as the first arm is in its deflected state rests over the needle shaft.

[17] The first and second retaining arms, thus, help to retain the first and second arms of the tip protector assembly in the catheter hub in its ready position prior to use preventing the premature release of the tip protector assembly from the catheter hub before the needle tip is safely received inside the first and second arms of the tip protector assembly.

[18] According to an embodiment, the tip protector assembly is retained at least partially and/or completely inside and/or outside the catheter hub and is prevented from movement in the axial direction relative to the said catheter hub. The catheter hub is provided with second retaining means which may be provided inside and/or outside of the catheter hub for engaging and/or releasing the first retaining means provided in the tip protector assembly.

[19] According to an embodiment, the needle can be moved through the catheter hub and the catheter tube when the tip protector assembly is in a ready position and to a tip protecting position in which the tip of the needle is fully received in the tip protector assembly and wherein a locking mechanism is provided to secure the tip protector assembly together with the catheter hub when the tip protector assembly is in its ready position.

[20] According to an embodiment, the first arm and second arms of the tip protector assembly are provided with one or more first retaining means which is adapted to engage with the one or more second retaining means provided in the inner wall of the catheter hub which provides an additional safe and reliable engagement between the two components as long as the tip protector assembly is in its ready position. Thus, the present invention is also directed to a locking mechanism to secure steadily the tip protector assembly preventing any movement while it is retained with the catheter hub.

[21] According to an embodiment, first retaining means provided on the first and second

arms of the tip protector assembly include one or more retaining protrusions, for example disc-like retaining protrusion or annular disc like retaining protrusion or at least part annular disc like retaining protrusion or combination thereof provided in the region of the distal ends of the first and second arms. According to a preferred embodiment, the retaining protrusion is of part-circular, in particular semi-circular shape. More specifically, the retaining protrusion may have generally parallel proximal and distal faces and/or convex, in particular part-cylindrical, peripheral surface. The retaining protrusions are adapted to engage with second retaining means provided in the inner wall of the catheter hub. The second retaining means include one or more retaining depressions for example, a retaining recess/groove or annular retaining recess/groove or at least part annular recess/groove or combination thereof formed on the inner circumferential wall of the catheter hub. In an alternative embodiment, the first retaining means may be one or more depressions and second retaining means may be one or more protrusions. As a further alternative, the first and second retaining means may also be formed by a combination of one or more retaining protrusions and one or more retaining depressions.

[22] According to an embodiment, the first retaining means provided on the first and second retaining arms include one or more retaining protrusions, for example hook or lug-like retaining protrusions adapted to engage with the second retaining means. In an alternative embodiment, the first retaining means may be formed by one or more retaining depressions, for example retaining recess/grooves. As a further alternative, the first retaining means may also be formed by a combination of one or more retaining protrusions and one or more retaining depressions.

[23] According to an embodiment, the second retaining means provided on outer wall of the catheter hub include one or more retaining depressions, for examples, retaining recess/groove adapted to retain the first retaining means. In an alternative embodiment, the second retaining means may be formed by one or more retaining protrusions, for example hook or lug-like retaining protrusion. As a further alternative, the second retaining means may also be formed by a combination of one or more retaining protrusions and one or more retaining depressions.

[24] According to an embodiment, the distal end of the transverse segments of the first and second retaining arms are angled and extend distally from the transverse segments and are slightly tilted towards the first and second arms forming an angle in the range between 0° to 10° . This angled extension and orientation of the first and second retaining arms provide restoration force and help the arms to act as springs having elastic properties thereby improving the retaining effect of the retaining arms with the second retaining means provided on the catheter hub. The first and second retaining arms engage with an outer surface of the catheter hub and help to retain the tip

protector assembly in the catheter hub prior to use of the catheter, thus preventing the tip protector assembly from being removed from the catheter hub before the needle tip is safely received inside the tip protector assembly.

[25] According to an embodiment, the first arm includes a first free end and the second arm includes a second free end extending generally axially in a distal direction from the base portion. The first free end extends beyond the second free end and overlaps the second free end by an angled end section including a length and width configured to retain the tip of the needle within a tip holding space so that in protected position the angled end section abuts the needle, in particular the tip of the needle. The length and width of the angled end section are larger than the maximum outer profile of the needle and/or its diameter and adapted to confine the needle tip within a tip holding space.

[26] As a preferred alternative, angled end section of the first arm may have an undercut for catching the needle tip. Further, the portion forming the angled end section may be made of a second material different from the first material forming, for example the first and second arms of the tip protector assembly such that harder plastic material or portion reinforced with metal material or the like so that the needle abutting the angled end section cannot pierce through it and be retained firmly in the needle tip holding space even under application of excessive force.

[27] According to an embodiment, each of the at least one side of the inner walls of the first and second arms of the tip protector assembly has internal recess close to the base portion thereof forming a cavity or cut out. The extension of the region above the said internal recess towards the distal end in the axial direction forms protective side-flaps in at least one side thereof providing an enclosure for the needle passing therethrough. The protective side-flaps provided on the first and second arms surround the needle shaft when passing through the first and second arms. The distal end of each of the internal recess in the first and second arms defines a shoulder. The side-flaps help prevent the needle tip from protruding sideways out of the tip protector assembly, thereby further increasing the protective function thereof. Moreover, the internal recesses provided in the arms facilitate deflectability and also improves restoration capabilities thereof. In particular, the internal recess provided in the first arm helps in improving deflectability as well as the restoration properties of first arm when the distal angled end thereof is no longer supported on the needle shaft. Thus, the internal recess increases the deflectability of the arms in the regions it is provided and thereby reduces the restoring force acting thereon, in particular on the angled end section of the first arm while it is being supported by the needle shaft. This allows the needle to be moved more easily relative to the first and second arms and in particular relative to the angled end section, as the frictional force acting on the needle is reduced. In the embodiment, where a floating stopper element e.g. a floating disk or washer is provided

as a stopper element the shoulder formed by distal end of the said internal recess in the first and second arms act as movement limiting means.

- [28] According to an embodiment, a tension creating element surrounds the first and second arms of the tip protector assembly, for example an elastic band in between the proximal and distal region of the first and second arms, in particular in a region proximal to the distal end of the first and second arms. The tension creating element exerts a restoring force on the first and second arms when tip protector assembly is in its ready position i.e. when the first and second arms are spread apart by the needle extending all the way through the tip protector assembly. Once the needle shaft no longer supports the angled end section of the first arm i.e. when the tip protector assembly is in its tip protecting position, the tension creating element aids the repositioning of the first arm back into axial alignment with the axial direction. This repositioning is necessary so that the angled end section can block the needle tip from axially sliding out of the tip protector assembly. In addition, the tension creating element defines a tip holding enclosure between the first and second arms and thus helps to prevent the needle shaft and the needle tip from protruding sideways out of the tip protector assembly. Thus, the tension creating element adds to the protective effect of the tip protector assembly by applying a radially confining biasing force.
- [29] In a preferred alternative, the tension creating element partly surrounds the first and second arms of the tip protector assembly i.e. instead of surrounding the two arms the tension creating elements biases the two arms by a linear biasing action.
- [30] In another preferred alternative, the tension creating element have the structure forming a link connecting the said first and second arms and which may be positioned and/or arranged in at least one of the either sides of first and second arms of the tip protector assembly.
- [31] In yet another preferred alternative, the tension creating element may have the structure forming a link connecting the said first and second arms and which may be positioned and/or arranged in both sides of first and second arms of the tip protector assembly.
- [32] In one embodiment, the tension creating element includes the structure in the form of a ring.
- [33] In one embodiment, the tension creating element may not be a separate component of the tip protector assembly and can be integrally made therein. It may be made from an elastic material and/or materials having elastic properties, for example, silicone, rubber or the like.
- [34] In one embodiment, the tension creating element may be arranged or positioned in any of the region in between the proximal and distal regions of the first and second arms of the tip protector assembly.

- [35] The change in profile may be defined as a needle section having a different dimension than the nominal diameter and may be created using various means. The change in profile may be for example, an enlargement and it may be made by crimping a portion of the needle either only on one side or point on the circumference of the needle or alternatively along both sides or symmetrically along the circumference of the needle.
- [36] In a preferred alternative, the change in profile may be formed in the form of a shoulder, bulge formed as an annular widening and by adding material onto the outer surface of the needle or by adding a sleeve to the needle for example, by welding, gluing or soldering etc. The added material may include a metal material, a plastic material, adhesive, resin or the like. In the case of the added material being metal material, the change in profile may, for example, be formed by build-up welding or by soldering of the additional material onto the needle. Alternatively, the additional material could be glued to the needle. The change in profile in the form of an enlargement may be referred to as a crimp, a sleeve, an annular sleeve, a part annular sleeve, a bulge, a section of the needle with added material or combinations thereof. Further, the inner profile of the needle can either be reduced in the region of the change in profile, for example, if the change in profile is formed by crimping, or it can be substantially constant throughout the length of the needle, for example, if the change in profile is formed by applying additional material to the needle shaft.
- [37] In one embodiment, the needle shaft may also be formed with a slit forming an opening arranged distally or proximally from the change in profile therein. The opening may be formed by a small slit which is cut into the needle shaft and which extends in axial direction for a small distance, for example 0.3 to 1mm. The opening is just large enough in order to provide an early blood flashback function close to the needle tip within the catheter tube such that the medical practitioner can recognize that needle has been placed correctly within the patient's vein. In case of correct positioning of the needle, blood pours out of the opening within the needle shaft into the space between the needle shaft and the inner wall of the transparent catheter tube and visible to the medical practitioner.
- [38] In one embodiment, a groove may be provided either in the inner wall of one of the first and second arms extending substantially in the axial direction from the base portion. The groove acts as a guide groove for the needle shaft and aids the axial movement of the needle shaft relative to the tip protector assembly. Moreover, the needle shaft is prevented from sliding sideways, in particular off the angled end section of the first arm. Such a sideways movement would significantly increase the force required to move the needle shaft relative to the tip protector assembly, which would prevent a correct functioning of the tip protector assembly. Alternatively, the guide

groove can be provided in both the first and second arms.

- [39] In one embodiment, the tip protector assembly is made from a unitary plastic material or, or an elastomer or thermoplastic or any combination thereof such as thermoplastic elastomer. In other embodiments, the tip protector assembly is made from multi-pieces and includes materials such as metal and/or plastic or any combination thereof. For example, either of the first and second arms or both may be made of a resilient material or plastic material or metal material or combination thereof.
- [40] In one embodiment, the stopper element is arranged within the base portion and can be integrally formed within the base portion of the tip protector assembly. The stopper element is made of a second material different from a first material of the base portion and has a through-bore with a profile which is adapted to the principal outer profile of the needle shaft. Preferably, the stopper element defines an axial bore having a cross-section adapted to the principal profile of the needle but being smaller than the radial dimension of the change in profile in the form of an enlargement forming the engagement means configured on the needle shaft. The stopper element is preferably arranged such that its axial-bore is in general alignment with the needle passage of the tip protector assembly.
- [41] According to an embodiment, the stopper element surrounds the needle. The length of the stopper element, i.e. its dimension seen in the axial direction, may vary. As such, the stopper element can, for example, be disk or a ring or a washer or a tube. However, it is to be understood that the outer profile of the stopper element does not have to have a circular outer profile. It is also possible that the outer profile of the stopper element is of non-circular form, for example, of oval or polygonal shape or other suitable geometric shape.
- [42] According to an alternative, it is also possible that the stopper element only partly surrounds the needle. In this case, the stopper element could have the shape of a slotted disk, ring or tube.
- [43] As yet another preferred alternative, the stopper element may also be arranged loosely on the needle between the two arms of the tip protector assembly and floating on the needle shaft and can be held in the area defined by the internal recess of the first and second arms. As such the stopper element may be formed by a tube-like element. It can be held by holding means, like one or more retaining protrusions or retaining depressions in a predetermined section of the tip protector assembly, for example in a region proximal to the base portion of the tip protector assembly. Alternatively, the stopper element can be arranged in floating condition in a pre-determined section in between the first and second arms of the tip protector assembly anywhere in between the proximal section and distal section thereof along the line of needle passage configured therein.

[44] To define the reference to first material and second material as used herein, preferably, the second material is of greater hardness and/or stiffness than the first material. For example, the first material could be a plastic material and the second material could consist of a metal, a harder fiber material, a rubber material or a ceramic, or any other type of suitable material which is stiff and not as easily distortable as the first material.

[45] Yet another embodiment of the present invention relates to methods of making/ assembling and using an IV catheter assembly including the tip protector assembly when the tip protector assembly is in its ready position.

[46] Further advantageous embodiments of the invention and preferred assemblies for carrying out the invention are disclosed in connection with the accompanying drawings.

[47] **BREIF DESCRIPTION OF THE DRAWINGS**

[48] The present invention will now be explained in more detail in the following with reference to preferred embodiments and to the accompanying drawings in which are shown:

[49] Fig. 1A illustrates an IV catheter assembly in accordance with the present invention illustrating the tip protector assembly in its ready position;

[50] Fig. 1B is a sectional illustration of an IV catheter assembly in accordance with the present invention illustrating the tip protector assembly in its ready position;

[51] Fig. 2 illustrates a needle, needle hub and tip protector assembly in its protective position being removed from the IV catheter assembly of Fig. 1;

[52] Figs. 3A - 3F illustrate the tip protector assembly of Figs. 1A and 1B wherein the tension creating element has been omitted for the sake of clarity;

[53] Figs. 4A - 4B illustrate two sectional illustrations of the details of tip protector assembly of Figs. 3A - 3F wherein the tension creating element has been omitted for the sake of clarity;

[54] Fig. 5 - illustrate sectional illustration of tip protector assembly of Figs. 3A - 3F wherein the tension creating element has been omitted for the sake of clarity;

[55] Fig. 6A - 6C are illustrations of different embodiments of the needles.

[56] **DETAILED DESCRIPTION OF THE INVENTION**

[57] As used herein, the term 'proximal' refers to a region of the assembly/device or a location on the assembly/device which is closest to, for example, a medical practitioner using the assembly/device. In contrast to this, the term 'distal' refers to a region of the assembly/device which is farthest from the medical practitioner, for example, the distal region of a needle will be the region of a needle containing the needle tip which is to be inserted e.g. into a patient's vein.

[58] Further, as used herein the term first and second are merely identifiers and do not

necessarily limit and/or restrict the features with such identifiers. For example, when viewed from another perspective, the first arm may be called the second arm and vice-versa.

[59] The various embodiments of present invention are directed to an IV catheter assembly including a tip protector assembly.

[60] Fig. 1A and 1B show an IV catheter assembly 10 in accordance with the invention prior to use illustrating the tip protector assembly 12 being in its ready position. The catheter assembly 10 includes a catheter tube 26 having distal 30 and proximal 28 ends and a catheter hub 24 attached to the catheter tube 26 at the proximal end 28 of the catheter tube 26. The catheter hub 24 has an inner profile 32 which defines a chamber 34 of generally circular cross-section in which the tip protector assembly 12 is retained (as shown in Fig. 1B). In Fig. 1 only first 58 and second 60 retaining arms of the tip protector assembly 12 can be seen.

[61] The IV catheter assembly 10 further includes a needle 14 extending through the catheter hub 24 and catheter tube 26 defining an axial direction A. The needle 14 has distal 30 and proximal 28 ends, wherein a sharp needle tip 18 is formed at the distal end 30 of the needle 14. A needle hub 20 is attached to the proximal end 28 of the needle 14. The needle shaft 16 has a generally constant principal profile, except for a change in profile 36, for example in the form of an enlargement 38 of the radial dimension of the needle 14 in at least one direction as compared to the principal profile. Preferably, the change in profile 36 is provided in the region closer to the proximal end 28 of the needle 14. The change in profile 36 may be defined as a needle section having a different dimension than the nominal diameter and may be created using various means and which forms an engagement means. The change in profile 36 can be made, for example, by crimping the needle shaft 16. The function of the engagement means will be discussed in more detail further below.

[62] A port member 44 (not shown) may be mounted on the catheter hub 24 at a proximal section 40 thereof, which makes it possible to connect, for example, a tube line to the catheter assembly 10 for collecting blood from a patient or delivering a fluid to be administered to a patient.

[63] Prior to use of the catheter assembly 10 as shown in Figs. 1A and 1B, the needle 14 extends all the way through the chamber 34 of the catheter hub 24 as well as the catheter tube 26 and the needle tip 18 protrudes from a distal end 30 of the catheter tube 26. As mentioned above, this position of the needle 14 is also referred to as the 'ready position' in this context. A tip protector assembly 12 is movably arranged on the needle shaft 16 such that a substantial portion thereof is retained in the chamber 34 defined by the catheter hub 24. The purpose of the needle tip protector assembly 12 is to cover the needle tip 18 after placement of the catheter tube 26 in and withdrawal of

the needle 14 from the patient's vein. This position can be referred to as 'tip protecting position' (Fig. 1B).

[64] When the needle 14 is withdrawn from the catheter tube 26 and catheter hub 24 the needle shaft 16 moves relative to the tip protector assembly 12 being retained in the chamber 34 of the catheter hub 24 by the first retaining means 64 provided on the first 50 and second 52 arms and first 58 and second 60 retaining arms in an engaging arrangement with the second retaining means 66 provided inside and/or outside the catheter hub 24 defining a chamber 34. Once the needle tip 18 is received in the tip protector assembly 12 and passes the angled end section 54 of the first arm 50, at this point the angled end section 54 is no longer supported on the needle shaft 16 and a restoring force ensures that the first arm 50 of the needle 14 is moved back into alignment with the axial direction A into its tip protecting position so that the needle tip 18 is blocked by the angled end section 54 of the tip protector assembly 12. At the same time, it is to be understood that the change in profile 36 e.g. in the form of the enlargement 38 engages with the base portion 46 of the needle shaft 16 and in particular with the stopper element 88 therein such that the tip protector assembly 12 can be pulled out of the catheter hub 24 together with the needle 14. In such position, the first retaining means 64 provided on the tip protector assembly 12 also disengage from the second retaining means 66 provided inside and/or outside the catheter hub 24 by the pulling force acting on the tip protector assembly 12 via the needle 14 and the stopper element 88. An axial movement of the needle 14 relative to the tip protector assembly 12 is now limited, as the angled end section 54 blocks the needle tip 18 and the base portion 46 in particular the stopper element 88 therein prevents the needle tip 18 from being removed via the base portion 46 and thus the needle tip 18 is safely surrounded by the tip protector assembly 12, as is shown in Fig. 2.

[65] As can be seen in more detail in Figs. 3A-3F, 4A-4B and 5, the tip protector assembly 12 includes a base portion 46 at a proximal end 28 thereof. First 50 and second 52 arms extend from a distal side/end 30 of the tubular base portion 46 generally in the axial direction A. The base portion 46 has a thorough bore 48 for receiving the needle 14 extending in the axial direction A. The profile of the bore is adapted to the principle outer profile of the needle 14. The first arm 50 of the tip protector assembly 12 is longer than the second arm 52 and has a distal section 42 which is angled towards the second arm 52 and substantially overlaps with the second arm 52, forming the angled end section 54 preferably having an undercut for catching the needle tip 18. In its ready position (Fig. 1A), the needle 14 extends completely through the tip protector assembly 12. In this position, the angled end section 54 of the first arm 50 is supported on the needle shaft 16 thereby deflecting the first arm 50 radially outwards.

- [66] In contrast to the first arm 50 and because of lack of distal angled end section 54, the second arm 52 has less deflectability than the first arm 50 when the needle 14 extends through the tip protector assembly 12. Nevertheless, in order to facilitate deflectability of both the first 50 and second 52 arms, each of the at least one side of the inner walls 68 of the first 50 and second 52 arms of the tip protector assembly 12 has an internal recess 72 close to the base portion 46 thereof forming a cavity or cut out 74. The extension of the region above the said internal recess 72 towards the distal end 30 in the axial direction A forms a protective side-flap 76 (Figs. 4A and 4B) in at least one side thereof providing an enclosure for the needle 14 passing therethrough in both the first 50 and second 52 arms. The protective side-flaps 76 provided in at least one side of the first 50 and second 52 arms surround the needle shaft 16 when passing through the first 50 and second 52 arms. Moreover, the protective side-flaps 76 help prevent the needle tip 18 from protruding sideways out of the tip protector assembly 12, thereby further increasing the protective function thereof. It is to be understood that the protective side-flap 76 can be provided on either sides of the first 50 and second 52 arms in a similar manner. Further, such an internal recess 72 can be formed both on the inner 68 and outer 70 walls of the first 50 and second 52 arms or in a combination of the inner 68 and outer wall 70 of the first 50 and second 52 arms.
- [67] The tip protector assembly 12 is also provided with first 58 and second 60 retaining arms in order to facilitate further the retention of the tip protector assembly 12 in the chamber 34 of the catheter hub 24, and in particular to prevent removal of the tip protector assembly 12 from the catheter hub 24 upon withdrawal of the needle 14 before the needle tip 18 has been safely received in the tip protector assembly 12. The first 58 and second 60 retaining arms thus prevent the tip protector assembly 12 retained in the catheter hub 24 from moving in a radial direction within the chamber 34.
- [68] The first 58 and second 60 retaining arms as shown in greater detail in Figs. 3A, 3B, 4A, 4B and 5 are connected to the base portion 46 of the tip protector assembly 12 by a transverse segment 56 extending in a direction opposing each other. The distal ends 30 of the transverse segments 56 of the first 58 and second 60 retaining arms are angled and extend distally from the transverse segments 56 and are slightly tilted towards the first 50 and second 52 arms. Preferably, the first 58 and second 60 retaining arms form an angle in the range between 0° and 10° with the axial direction A, providing an open space 62 between the first retaining arm 58 and first arm 50 and second 60 retaining arms and second arm 52 of the tip protector assembly 12.
- [69] The distal ends 30 of the first 58 and second 60 retaining arms are also provided with first retaining means 64 in the form of one or more retaining protrusions 78, for example, at least one hook or lug-like retaining protrusion 78. When the tip protector

assembly 12 is in the ready position, first retaining means lockingly engage with the corresponding second retaining means 66 in the form of one or more retaining depressions 80, for example at least a pair of grooves or recesses in a direction opposing each other on the outer wall 70 of the catheter hub 24. Because of the engagement between the first retaining means 64 and second retaining means 66, the tip protector assembly 12 is prevented from axial movement relative to the catheter hub 24 and effectively retained in the catheter hub 24 until a pulling force exerted by the needle 14 on the base portion 46 of the tip protector assembly 12 via the change in profile 36 of the needle 14 upon withdrawal of the needle 14 from the catheter becomes great enough to disengage the first 58 and second 60 retaining arms from the second retaining means 66 of the catheter hub 24.

[70] It is to be noted that instead of the retaining depressions 80 provided on the outer wall 70 of the catheter hub 24 it is also possible to provide one or more retaining protrusions 78 or combination of either a protrusion 86 or a recess in the outer wall 70 of the catheter hub 24 to engage with the first 58 and second 60 retaining arms. Likewise, instead of the retaining protrusions 78 provided on the first 58 and second 60 retaining arms it is also possible to provide one or more retaining depressions 80 or combination of either a retaining protrusion 78 or a depression to engage with the catheter hub 24.

[71] In order to enhance further the retaining effect of the tip protector assembly 12 in the catheter hub 24, the distal ends 30 of the first 50 and second 52 arms are provided with first retaining means 64 (not shown). The first retaining means 64 include one or more retaining protrusions 78, for example disc-like retaining protrusion 78 or annular disc like protrusion 86 or at least part annular disc like protrusion 86 provided in the region of the distal ends 30 of the first 50 and second 52 arms. According to a preferred embodiment, the retaining protrusion 78 is of part-circular, in particular semi-circular shape. More specifically, the retaining protrusion 78 may have generally parallel proximal and distal faces and/or convex, in particular part-cylindrical, peripheral surface. The retaining protrusions 78 are adapted to engage with second retaining means 66 provided in the inner wall 68 of the catheter hub 24 when the tip protector assembly 12 is in its ready position. The second retaining means 66 include one or more retaining depressions 80 for example, a recess or annular recess/groove or at least part annular recess/groove formed on the inner circumferential wall of the catheter hub 24.

[72] In a preferred alternative, the first retaining means 64 provided on the first 50 and second 52 arms may be one or more retaining depressions 80 and second retaining means 66 provided on the inner wall 68 of the catheter hub 24 may be one or more retaining protrusions 78. As a further alternative, the first 64 and second 66 retaining means may also be formed by a combination of retaining protrusions 78 and retaining

depressions 80.

[73] As shown in Figs. 3A, 3B, 4A, 4B and 5, the base portion 46, the first 50 and second 52 arms, the first 58 and second 60 retaining arms are integrally formed, for example, from a plastic material by way of injection molding. However, it is to be understood that this integral design is not compulsory. Instead, one or more of the named components could be made of a material that is different from the material of the other components, for example of metal material, and this component could be attached to the other components, for example, by gluing, soldering, welding or the like.

[74] Even though the first 50 and second 52 arms are have certain elastic properties, a tension creating element 82, for example a rubber band, may surround preferably a distal section 42 of the first 50 and second 52 arms are such that deflection of at least the first arm 50 occurs mainly against a restoring force of the tension creating element 82. One or more protrusions 86 forming tapered outer surfaces 84 extending along the outer periphery of the first 50 and second 52 arms are provided in order to position the tension creating element 82 on the first 50 and second 52 arms are (Figs. 3A-3D). Because of the tapered outer surfaces 84 the tension creating element 82 is prevented from sliding off the distal sections 42 of the first 50 and second 52 arms are, when the first 50 and second 52 arms are spread apart against a restoring force of the tension creating element 82. In a preferred alternative, the tension creating element 82 may not be a separate component of the tip protector assembly 12 and can be integrally made therein.

[75] In another preferred alternative, the tension creating element 82 partly surrounds the first 50 and second 52 arms (not shown) of the tip protector assembly 12 i.e. instead of surrounding the two arms the tension creating elements 82 biases the two arms by a linear biasing action. In another preferred alternative, the tension creating element 82 have the structure forming a link connecting the said first 50 and second 52 arms (not shown) and which may be positioned and/or arranged in at least one of the either sides of first 50 and second 52 arms of the tip protector assembly 12. In yet another preferred alternative, the tension creating element 82 may have the structure forming a link connecting the said first 50 and second 52 arms (not shown) and which may be positioned and/or arranged in both sides of first 50 and second 52 arms of the tip protector assembly 12.

[76] As is best seen in Figs. 4A, 4B and 5, a stopper element 88 is provided in the base portion 46 or on the distal side/end of the base portion 46, for example by insert molding. The stopper element 88 has an axial bore 90 which is aligned with the thorough-bore of the base portion 46. The axial bore 90 has a circular cross-section with its diameter being slightly larger than the principle diameter of the proximal section 40 of the needle shaft 16 relative to the stopper element 88. More specifically,

the cross-section of the axial bore 90 of the stopper element 88 is adapted to the principal profile of the needle shaft 16 such that the stopper element 88 can slide along the needle shaft 16 with minimum friction. At the same time the diameter of the axial bore 90 is not only smaller than that of the needle passage 22 but also smaller than the maximum dimension of the change in profile 36 of the needle shaft 16, e.g. in the form of enlargement 38, in order to prevent the enlargement 38 from passing through the axial bore 90 and, thus, to prevent the tip protector assembly 12 from sliding off the needle 14.

[77] Preferably, such a stopper element 88 would be made of a second material of a greater hardness and/or stiffness different from the first material of the base portion 46, such that the stopper element 88 withstands greater force exerted by the change in profile 36 of the needle 14 upon withdrawal of the needle 14 from the catheter tube 26, thereby more effectively preventing the change in profile 36 of the needle 14 from passing through the base portion 46 and thus more effectively preventing the tip protector assembly 12 from sliding off the needle 14. Preferably, the stopper element 88 has a disk-like shape, similar to a washer or ring and is made of hard plastic, metal or ceramic and it can also be made out of any other material which is stiff and which can not easily be distorted.

[78] The fact that the stopper element 88 is made from a second material which is harder and less easily distortable than the first material of the base portion 46, has the effect that the tip protector assembly 12 is secured more effectively on the needle shaft 16 and can be retained even if excessive external force is applied when pulling on the needle 14, as the change in profile 36 in the form of, for example an enlargement 38 acting as engagement means is prevented from being pulled through the base portion 46 of the tip protector assembly 12. Hence, it is less likely that the tip protector assembly 12 is removed from the needle 14 tip accidentally and, as a result, the tip protector assembly 12 provides a better protection against accidental pricking and thus increased safety for the person handling the catheter assembly 10.

[79] Further, it is to be understood, that the stopper element 88 need not be arranged in the base portion 46 itself, but can also be arranged at the distal side/section 42 thereof between the first 50 and second 52 arms of the tip protector assembly 12. Thus, the position of the stopper element 88 in between the first 50 and second 52 arms can be selected freely.

[80] As a preferred alternative, the stopper element 88 may also be arranged loosely on the needle 14 between the two arms 50, 52 of the tip protector assembly 12 and floating on the needle shaft 16 and can be held in the area defined by the internal recess 72 of the first 50 and second 52 arms (not shown). As such the stopper element 88 may be formed by a tube-like element. It can be held by holding means, like one or

more retaining protrusions 78 or retaining depressions 80 in a predetermined section of the tip protector assembly 12, for example in a region proximal to the base portion 46 of the tip protector assembly 12. Alternatively, the stopper element 88 can be arranged in floating condition in a pre-determined section in between the first 50 and second 52 arms of the tip protector assembly 12 anywhere in between the proximal section 40 and distal section 42 thereof along the line of needle passage 22 configured therein.

[81] Fig. 6A shows an embodiment of a needle 14 having a needle shaft 16, a needle tip 18 and a change in profile 36 in the form of an enlargement 38 formed for example, by a crimp. The crimp is made by a local depression 92 such that lateral protrusions 94 resulting from the crimping process. Preferably, the crimping process is controlled such that the internal cross-sectional area of the needle 14 is not reduced substantially such that the internal profile of the needle shaft 16 is not affected.

[82] Fig. 6B shows the needle 14 according to Fig. 7A, however having a slit forming an opening 96 arranged slightly distally from the change in profile 36, such that it is still arranged within the catheter tube 26 in the ready position. The opening 96 just extends over about 0.5 mm in axial direction A and provides a through hole through the needle 14 wall. Thereby, an early blood flashback within the transparent catheter tube 26 can be achieved when the needle 14 is positioned into the patient's vein. Based on this blood flashback, the practitioner can see right after puncturing the patient whether the needle 14 has been positioned correctly due to a small amount of patient's blood oozing out the space between the needle shaft 16 and the transparent catheter tube 26.

[83] Fig. 6C shows the needle 14 according to Fig 6B, however with the slit forming an opening 96 arranged proximally from the change in profile 36. The opening 96 is dimensioned such that it does not affect the functioning of the tip protector assembly 12.

[84] It is to be understood that securing the tip protector assembly 12 partially in the chamber 34 of the catheter hub 24 by means of first 64 and second 66 retaining means with the catheter hub 24 is a simple measure achieving a safe seat of the tip protector assembly 12 and which effectively prevents accidental removal of the tip protector assembly 12 from the catheter chamber 34 prior to the needle tip 18 being received in the tip protector assembly 12. Not only this arrangement ensures correct protective function of the tip guard assembly 12 but also ensures that the tip protector assembly 12 is secured steadily inside the catheter hub 24 removing entirely the problem of premature release when pulling force applied on the needle 14 to withdraw/disengage the needle hub 20 from the catheter hub 24. Hence, the risk of premature release of the tip protector assembly 12 from the catheter hub 24 during withdrawal of the needle 14 from the catheter and catheter hub 24 and, thus, the risk of accidental pricking by the needle 14 is reduced.

[85] Moreover, the IV catheter assembly 10 including tip protector assembly 12 of the

invention can be manufactured at reduced costs while at the same time the safety of the IV catheter assembly 10 is increased. The IV catheter assembly 10 including the tip protector assembly 12 is particularly inexpensive to manufacture if the base portion, the first 50 and second 52 arms, first 58 and second 60 retaining arms are integrally made from a first material. The first material may, for example, be a plastic material. Thus, the base portion 46, the first 50 and second 52 arms and the first 58 and second 60 retaining arms could be manufactured by injection moulding.

[86] Alternatively, the base portion 46, one of the first 50 and second 52 arms and the first 58 and second 60 retaining arms could be integrally made from a first material, for example a plastic material and the other one of the first 50 and second 52 arms and the first 58 and second 60 retaining arms could be made from a second material different from said first material. For example, said one of the first 50 and second 52 arms could include a strip of material having spring-like properties, e.g. a strip of sheet metal or any other suitable material.

[87] Although this invention has been disclosed in the context of certain preferred embodiments and examples, it will be understood by those skilled in the art that the present invention extends beyond the specifically disclosed embodiments to other alternative embodiments and/or uses of the invention and obvious modifications and equivalents thereof. For example, the tip protector assembly 12 of the present invention can also be adapted such that without including the stopper element 88. In this case, the outer profile of the enlargement 38 on the needle shaft 16 must be greater than the profile of the thorough-bore 48 provided in the base portion 46 of the tip-protector assembly 12, in order to prevent the tip protector assembly 12 from sliding off the needle 14 in a distal direction. Thus, from the foregoing description, it will be apparent to one of ordinary skill in the art that many changes and modifications can be made thereto without departing from the spirit or scope of the invention as set forth herein.

[88] Accordingly, it is not intended that the scope of the foregoing description be limited to the exact description set forth above, but rather that such description be construed as encompassing all of the features of patentable novelty that reside in the present invention, including all the features and embodiments that would be treated as equivalents thereof by those skilled in the relevant art. Thus, it is intended that the scope of the present invention herein disclosed should not be limited by the particular disclosed embodiments described above.

[89] **REFERENCE NUMERALS**

[90] 10 IV catheter assembly

[91] 12 tip protector assembly

[92] 14 needle

[93] 16 needle shaft

- [94] 18 needle tip
- [95] 20 needle hub
- [96] 22 needle passage
- [97] 24 catheter hub
- [98] 26 catheter tube
- [99] 28 proximal end
- [100] 30 distal end
- [101] 32 inner profile
- [102] 34 chamber
- [103] 36 change in profile
- [104] 38 enlargement
- [105] 40 proximal section
- [106] 42 distal section
- [107] 44 port member
- [108] 46 base portion
- [109] 48 thorough bore
- [110] 50 first arm
- [111] 52 second arm
- [112] 54 angled end section
- [113] 56 transverse segment
- [114] 58 first retaining arm
- [115] 60 second retaining arm
- [116] 62 open space
- [117] 64 first retaining means
- [118] 66 second retaining means
- [119] 68 inner wall
- [120] 70 outer wall
- [121] 72 internal recess
- [122] 74 cavity or cut out
- [123] 76 protective side flap
- [124] 78 retaining protrusion
- [125] 80 retaining depression
- [126] 82 tension creating element
- [127] 84 tapered outer surface
- [128] 86 protrusion
- [129] 88 stopper element
- [130] 90 axial bore
- [131] 92 local depression

- [132] 94 lateral protrusion
- [133] 96 opening
- [134] Aaxial direction

Claims

[Claim 1]

A safety IV catheter assembly 10 comprising:

a catheter tube 26 having a distal end 30 and a proximal end 28;

a catheter hub 24 having a distal end 30 and a proximal end 28, wherein the distal end 30 is joined to the said catheter tube 26 and the proximal end 28 defines a chamber 34;

a needle 14 extending through the catheter hub 24 and the catheter tube 26 having opposite proximal 28 and distal 30 ends defining an axial direction A, wherein the proximal end 28 is joined to the needle hub 20 and the distal end 30 forms a sharp tip 18 and a change in profile 36 is provided between the proximal 28 and distal 30 ends of the needle 14; a tip protector assembly 12 movably arranged in between the catheter hub 24 and needle hub 20 on the needle 14 such that the tip protector assembly 12 is retained partially and/or completely in the chamber 34 of the catheter hub 24 including:

a base portion 46 in the region of its proximal end 28 having a needle passage 22 with a thorough bore 48 extending in an axial direction A from a proximal side of the base portion 46 to a distal side of the base portion 46;

first 50 and second 52 arms extending substantially in the axial direction A from the distal section 42 of the base portion 46;

at least one tension creating element 82 surrounding partially and/or completely the said first 50 and second 52 arms in a region proximal to the distal ends 30 thereof;

at least one stopper element 88 arranged in the base portion 46 having an axial bore 90 with a dimension adapted to the principal outer profile of the said needle 14;

at least one pair of first 58 and second 60 retaining arms connected to the base portion 46 by transverse segments 56 extending therefrom in a direction opposing each other; and

one or more first retaining means 64 in an arrangement engaging with the one or more second retaining means 66 provided on the inner 68 and/or outer 70 walls of the catheter hub 24 for retaining the tip protector assembly 12 in the chamber 34 as long as the first arm 50 is in its deflected state rests over the needle shaft 16.

[Claim 2]

The IV catheter assembly 10 as claimed in claim 1, wherein the first retaining means 64 include one or more retaining protrusions 78 or

- retaining depressions 80 or combination thereof arranged in the region of the distal ends 30 of the first 58 and second 60 retaining arms.
- [Claim 3] The IV catheter assembly 10 as claimed in claim 1, wherein the first retaining means 64 include one or more retaining protrusions 78 or retaining depressions 80 or combination thereof arranged in the distal section 42 of the first 50 and second 52 arms in a direction opposing each other.
- [Claim 4] The IV catheter assembly 10 as claimed in claim 1, wherein the second retaining means 66 include one or more retaining depressions 80 or retaining protrusions 78 or combination thereof arranged in the outer wall 70 of the catheter hub 24 in a direction opposing each other.
- [Claim 5] The IV catheter assembly 10 as claimed in claim 1, wherein the second retaining means 66 include one or more retaining depressions 80 or retaining protrusions 78 or combination thereof arranged in the inner wall 68 of the catheter hub 24 in a direction opposing each other.
- [Claim 6] The IV catheter assembly 10 as claimed in claim 1, wherein at least one side of the inner wall 68s of the first 50 and second 52 arms of the tip protector assembly 12 has internal recess 72 close to the base portion 46 thereof forming a cavity or cut out 74.
- [Claim 7] The IV catheter assembly 10 as claimed in claim 6, wherein the extension of the region above the internal recess 72 towards the distal end 30 in the axial direction A forms protective side-flaps 76 in at least one side thereof providing an enclosure for the needle 14 passing therethrough.
- [Claim 8] The IV catheter assembly 10 as claimed in claim 1, wherein the distal ends 30 of the transverse segments 56 are angled and extend distally from the transverse segments 56 and are slightly tilted towards the first 50 and second 52 arms forming an angle in the range between 0° to 10°.
- [Claim 9] The IV catheter assembly 10 as claimed in any one of claims 2 to 5, wherein the retaining protrusion 78 is a hook or lug-like retaining protrusion 78 or disc-like retaining protrusion 78 or annular disc like retaining protrusion 78 or at least part annular disc-like retaining protrusions 78 or combination thereof.
- [Claim 10] The IV catheter assembly 10 as claimed in any one of claims 2 to 5, wherein the retaining depression 80 is a retaining recess/groove or annular retaining recess/groove or at least part annular recess/groove or combination thereof.
- [Claim 11] The IV catheter assembly 10 as claimed in claim 1, wherein either of

- the first 50 and second 52 arms or both may be made of a resilient material or plastic material or metal material or combination thereof.
- [Claim 12] The IV catheter assembly as claimed in claim 1, wherein the first arm 50 includes a first free end and the second arm 52 includes a second free end extending generally axially in a distal direction from the base portion 46.
- [Claim 13] The IV catheter assembly 10 as claimed in claim 12, wherein the first free end extends beyond the second free end and overlaps the second free end by an angled end section 54.
- [Claim 14] The IV catheter assembly 10 as claimed in claim 13, wherein the length and width of the angled end section 54 are larger than the maximum outer profile of the needle 14 and/or its diameter and adapted to confine the needle tip 18 within a tip holding space.
- [Claim 15] The IV catheter assembly 10 as claimed in claim 1, wherein the change in profile 36 is formed by an enlargement 38 of the radial dimension of the needle 14 in at least one direction as compared with a principal profile of the needle 14 having an outer profile one dimension of which is larger than a maximum dimension of the profile of the thorough bore 48.
- [Claim 16] The IV catheter assembly 10 as claimed in claim 15, wherein the enlargement 38 is a crimp or a sleeve or a bulge or a section of the needle 14 with added material or combinations thereof.
- [Claim 17] The IV catheter assembly 10 as claimed in 1, wherein the stopper element 88 is arranged being integrally formed within the base portion 46 such that its axial-bore is in general alignment with the needle passage 22 and is made of a second material different from a first material of the base portion 46.
- [Claim 18] The IV catheter assembly 10 as claimed in claim 1, wherein the stopper element 88 surrounds the needle 14 and is a disk or a ring or a washer or a tube.
- [Claim 19] The IV catheter assembly 10 as claimed in claim 1, wherein the stopper element 88 partly surrounds the needle 14 and is a slotted disk, ring or tube.
- [Claim 20] The IV catheter assembly 10 as claimed in any one of the claims 17 to 19, wherein the stopper element 88 defines an axial bore 90 having a cross-section adapted to the principal profile of the needle 14 but being smaller than the radial dimension of the change in profile 36.
- [Claim 21] The IV catheter assembly 10 as claimed in claim 1, wherein needle

shaft 16 is formed with a slit forming an opening 96 arranged distally or proximally from the change in profile 36.

[Claim 22]

The IV catheter assembly 10 as claimed in claim 1, wherein the tension creating element 82 have the structure forming a link connecting the said first 50 and second 52 arms and arranged in at least one of the either sides of first 50 and second 52 arms of the tip protector assembly 12.

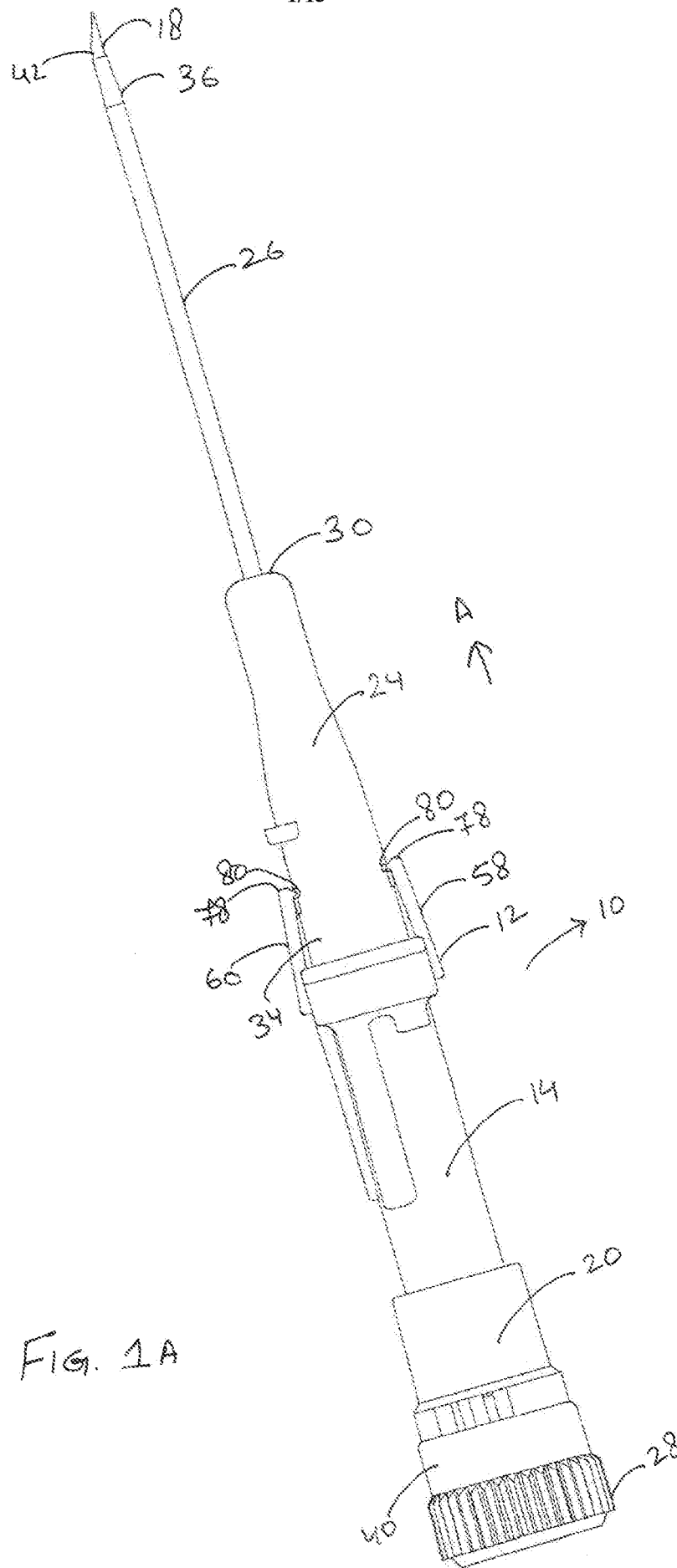

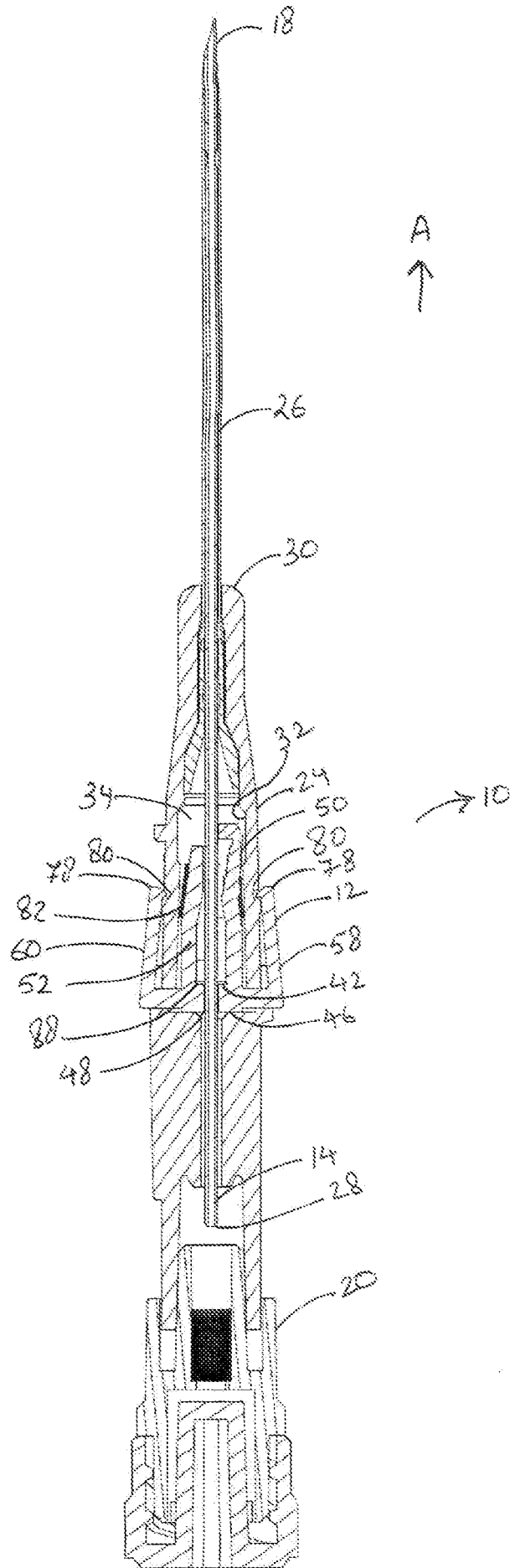

Fig. 18

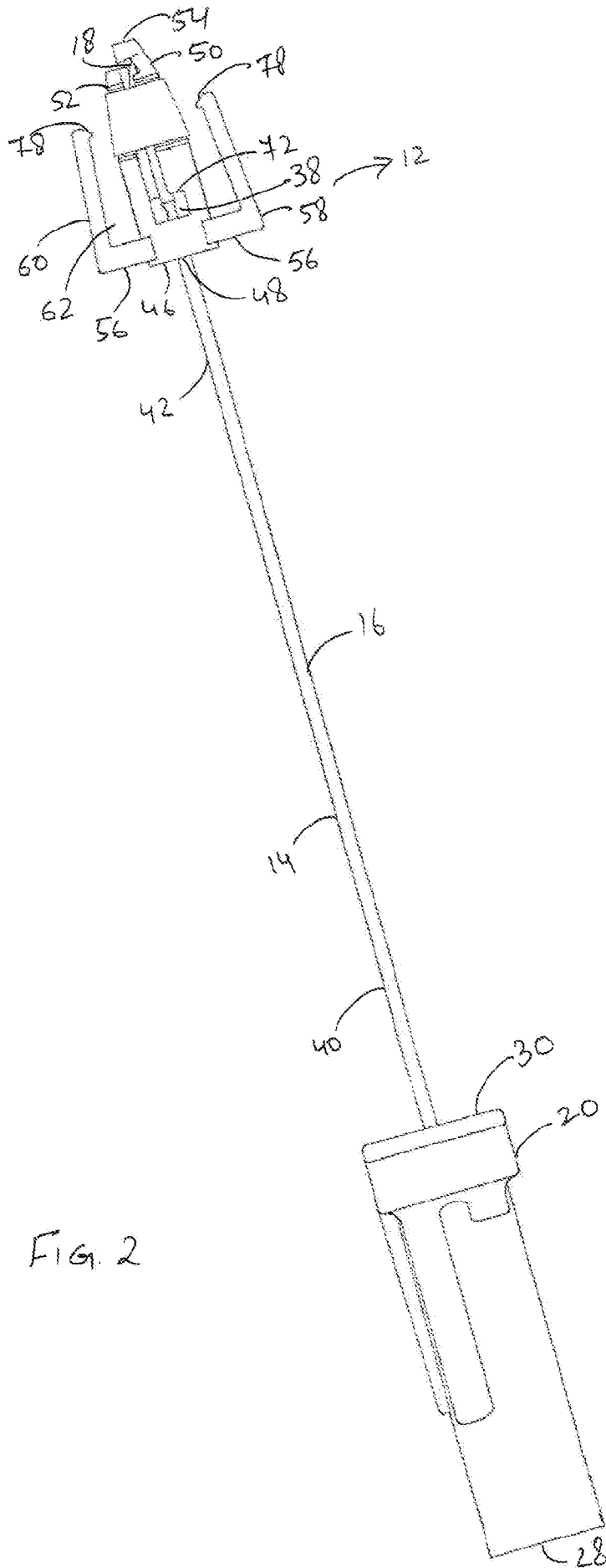

FIG. 2

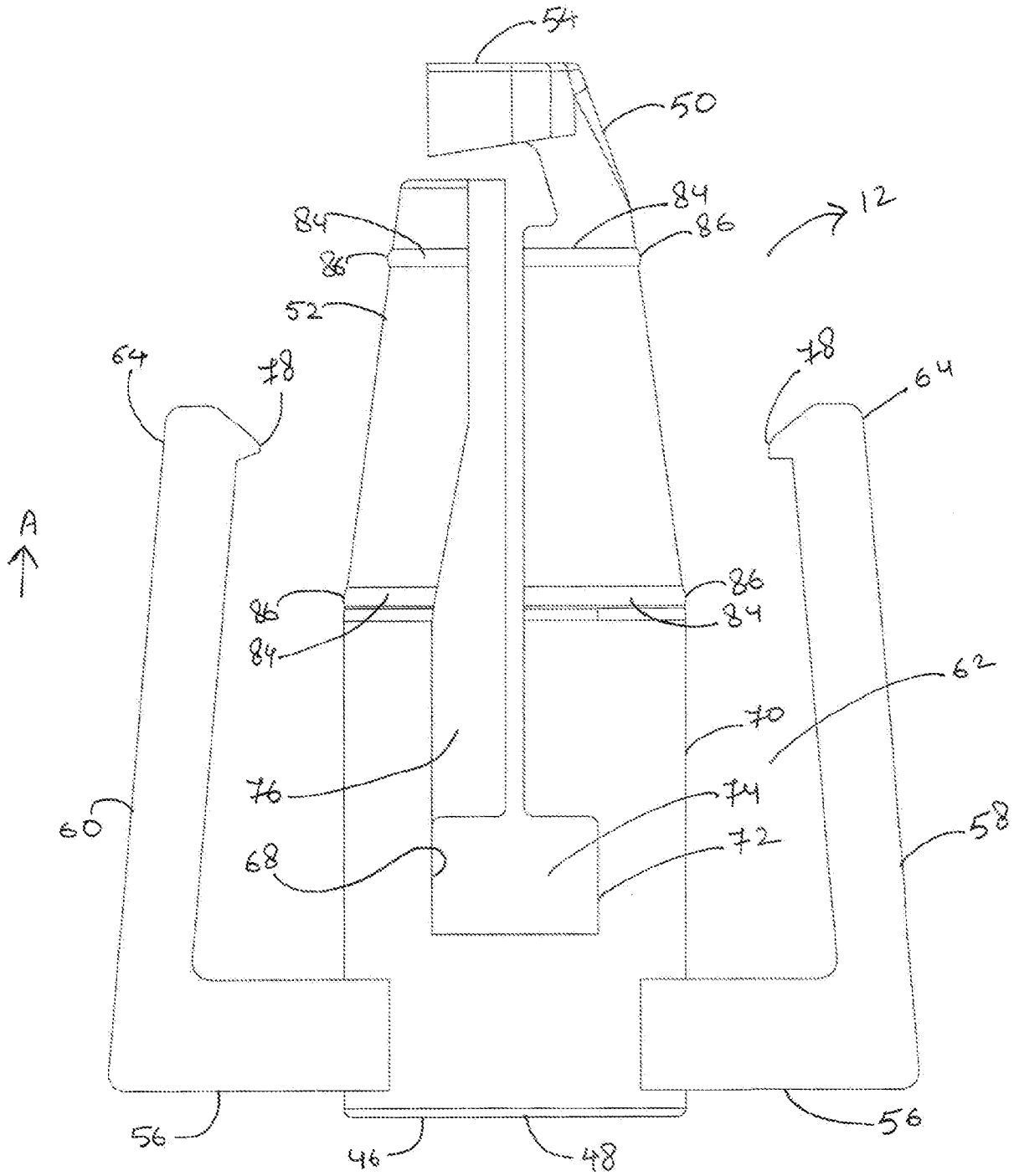

FIG. 3A

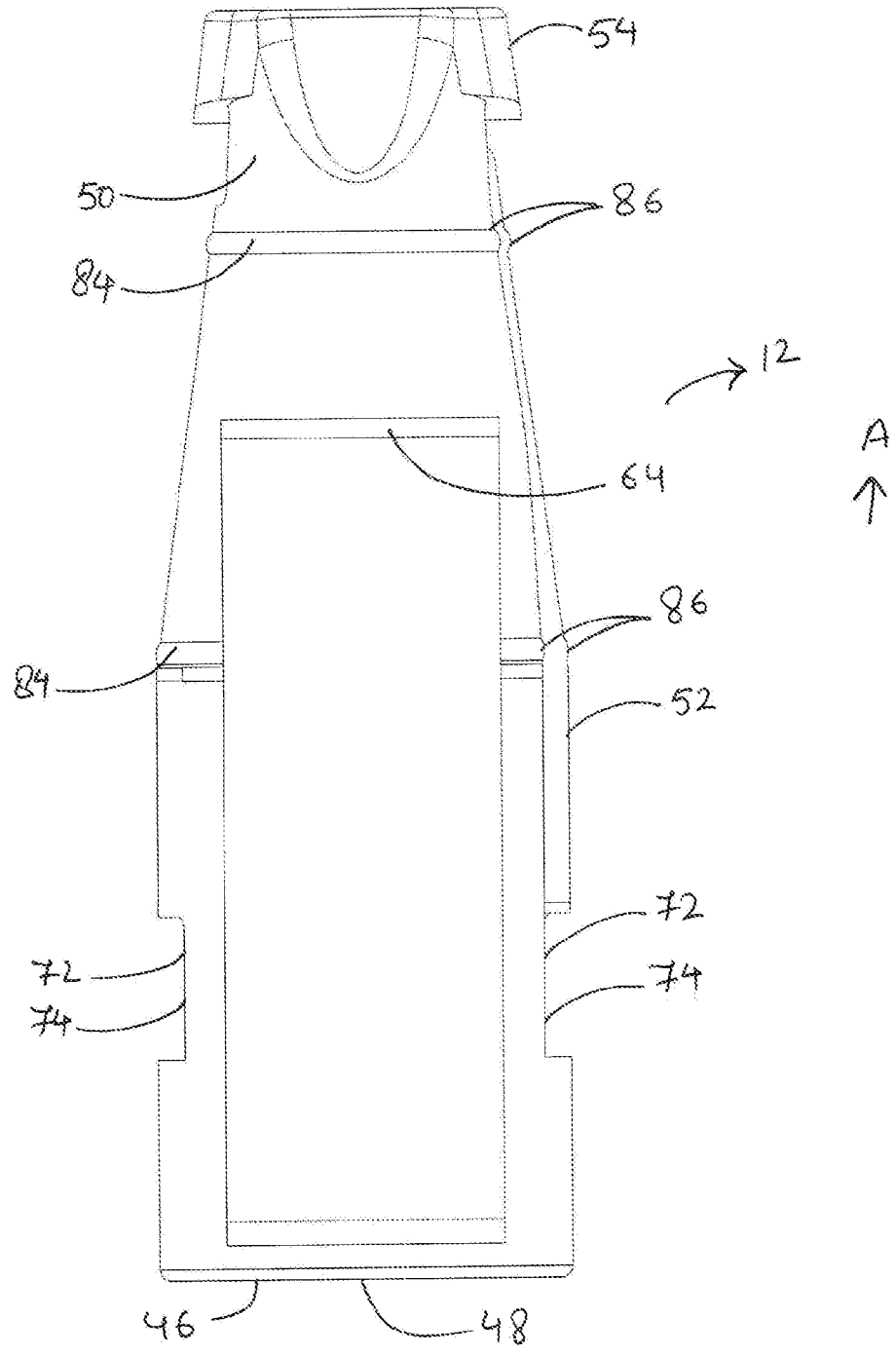

Fig 3C

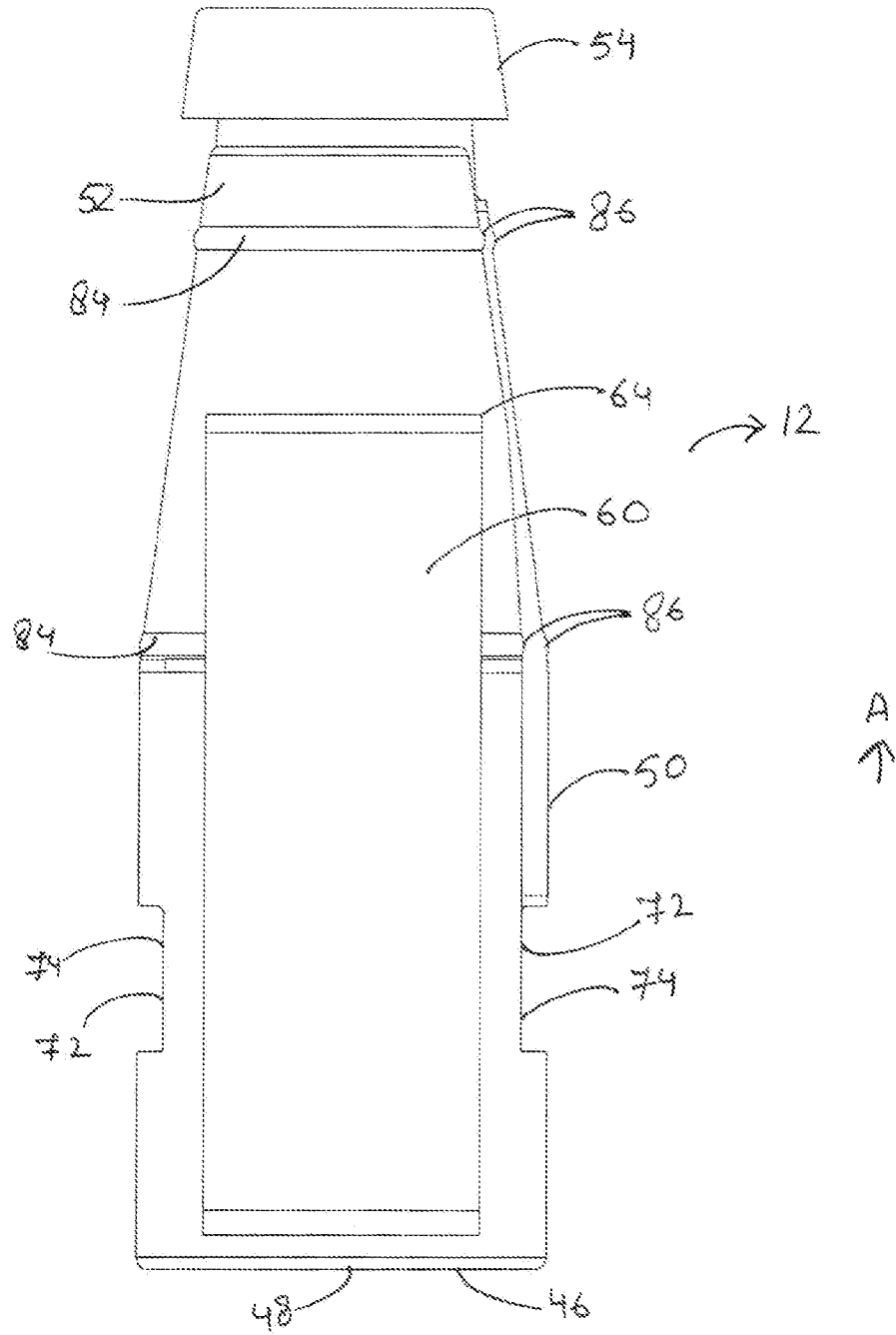

FIG. 3D

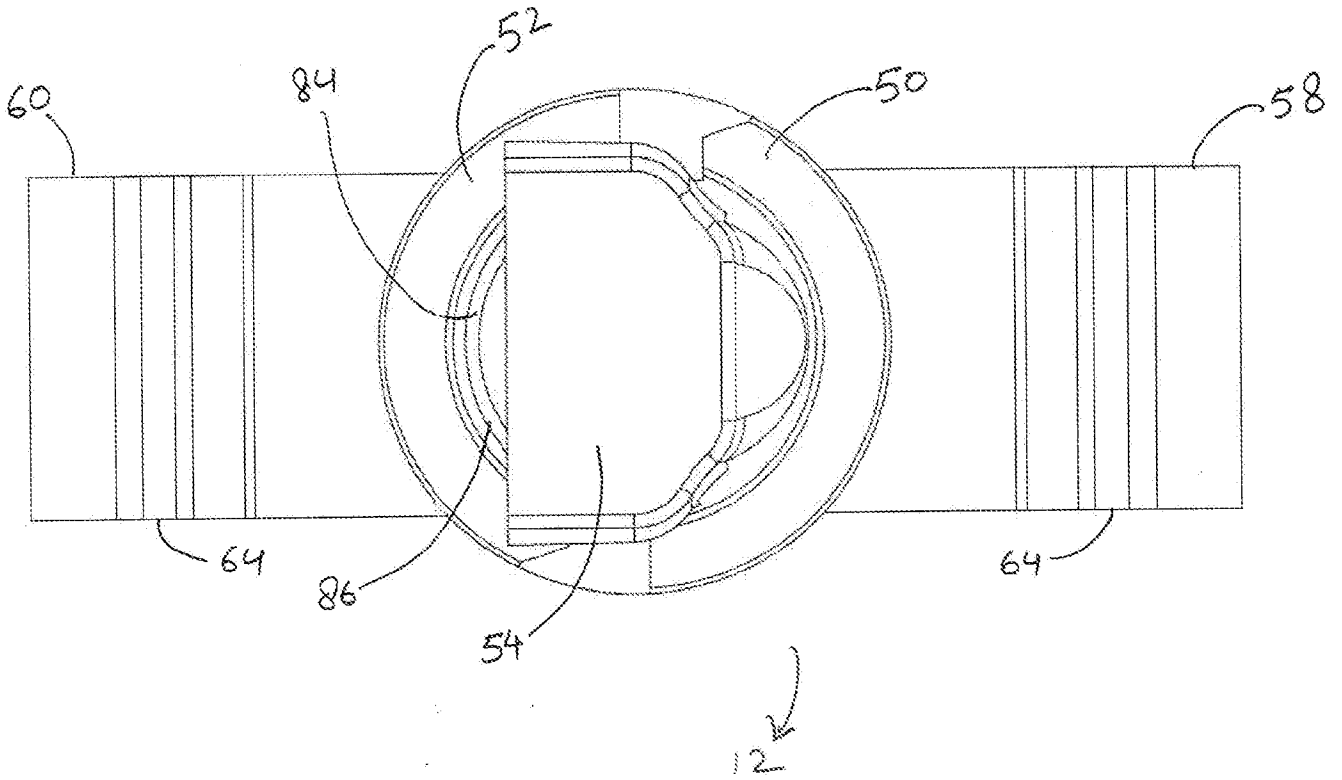

Fig. 3E

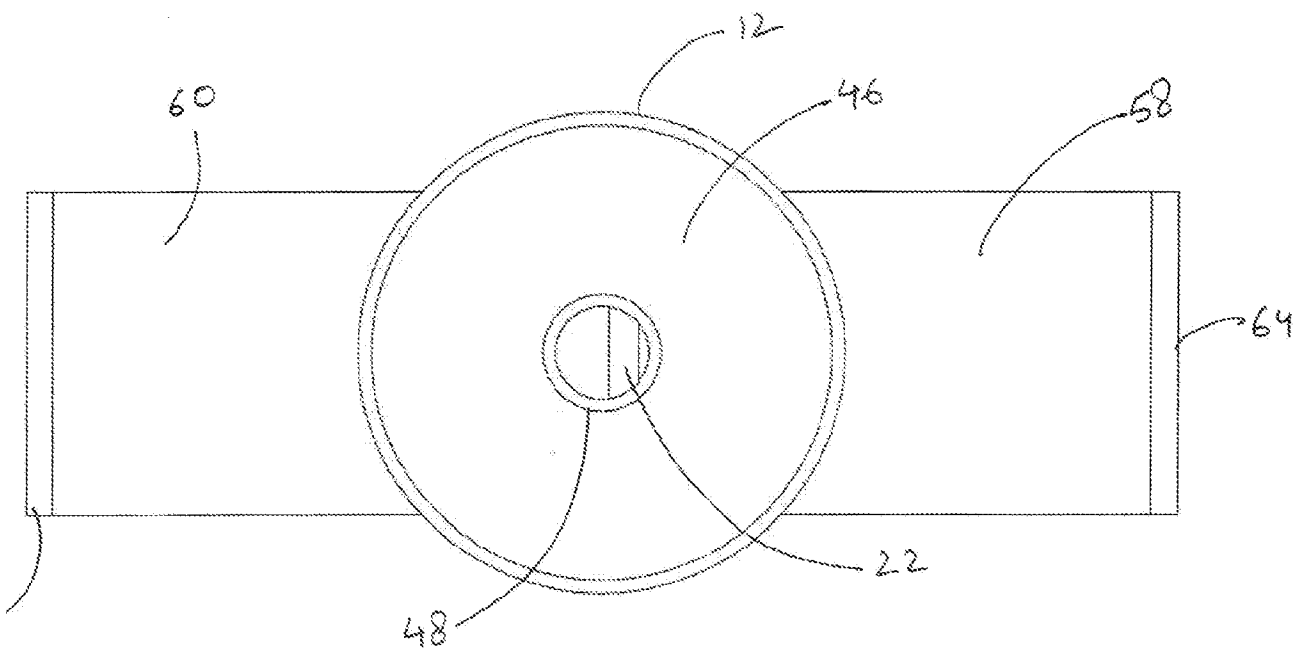

Fig. 3F

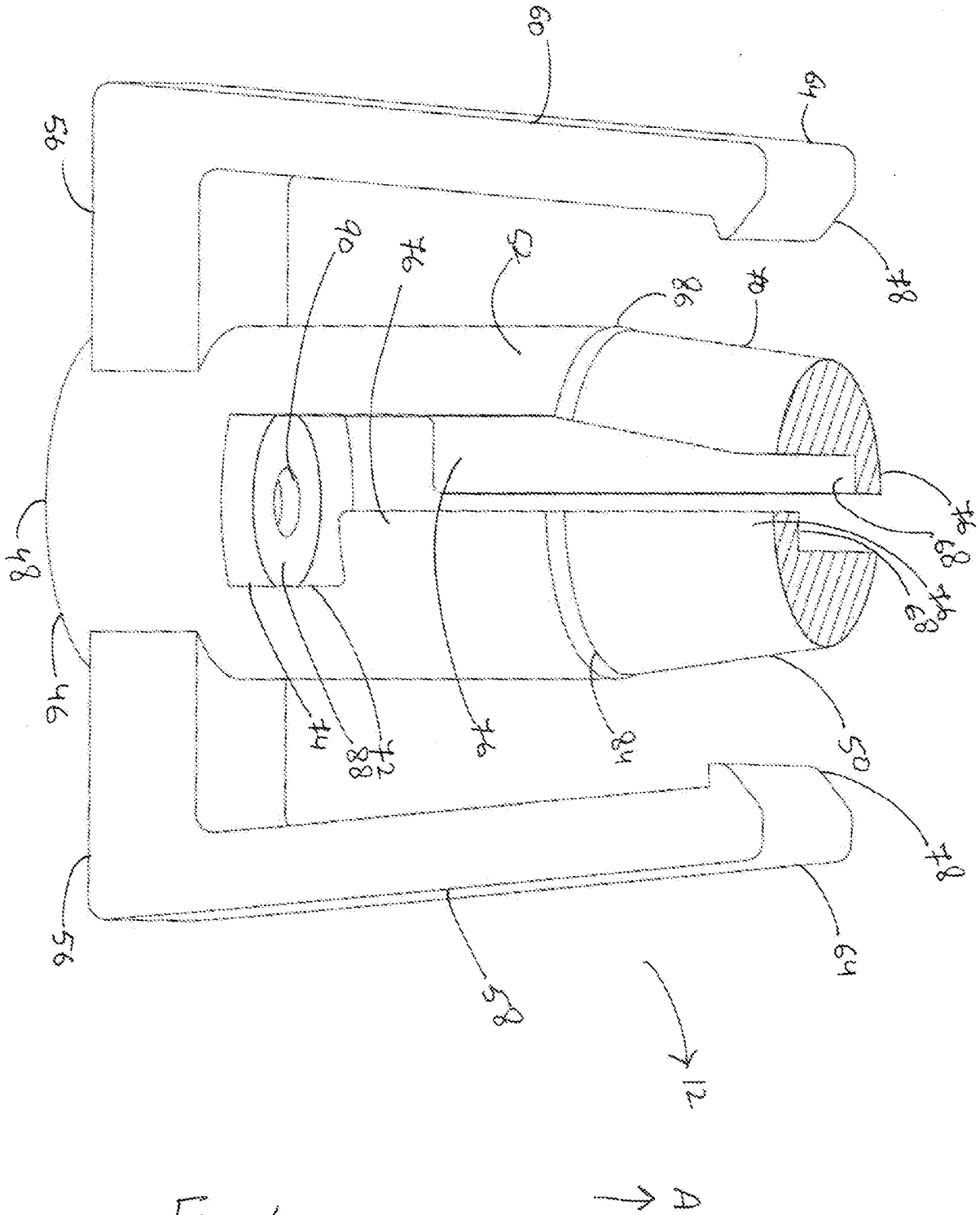

FIG. 4A

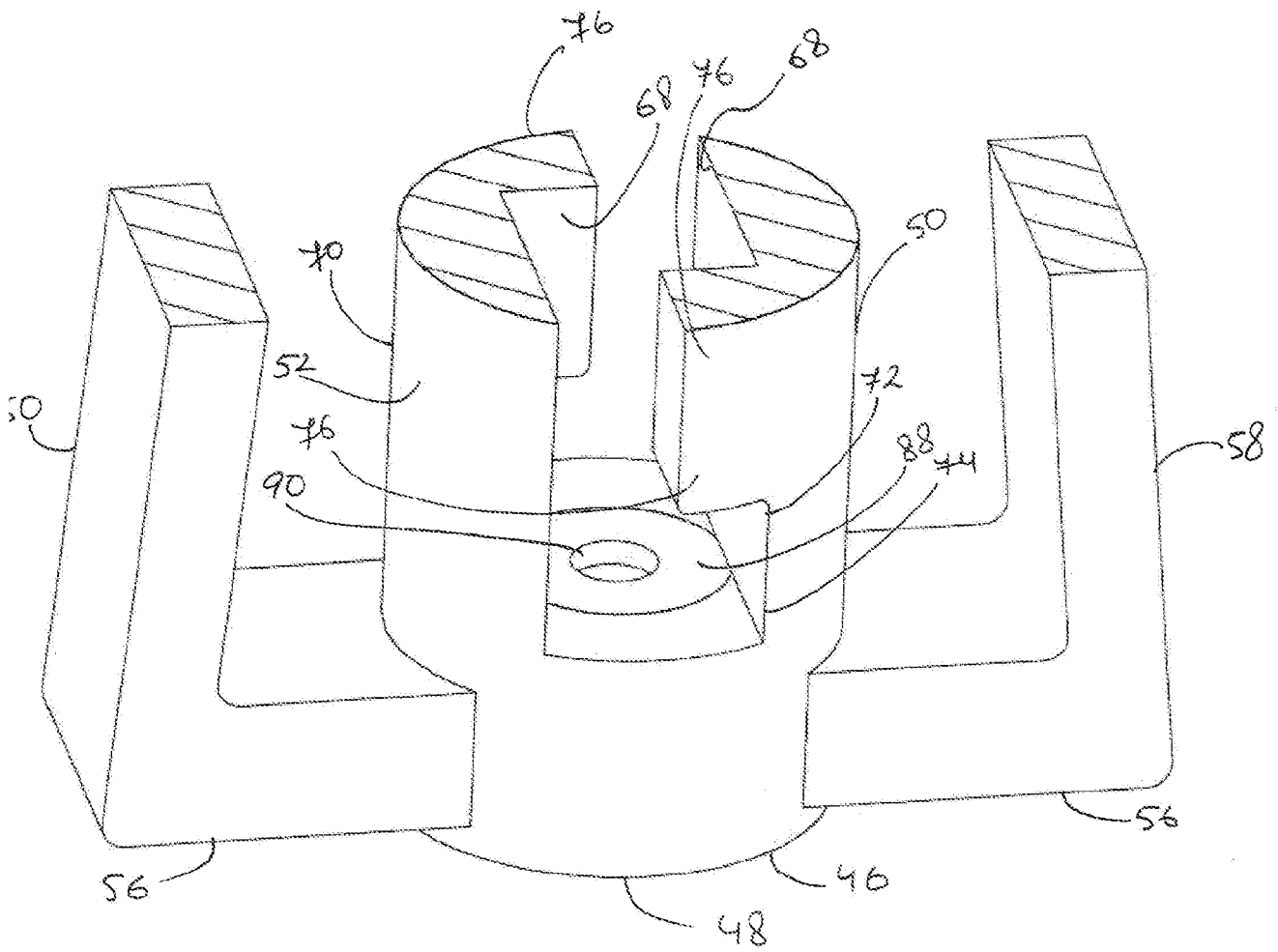

FIG. 4B

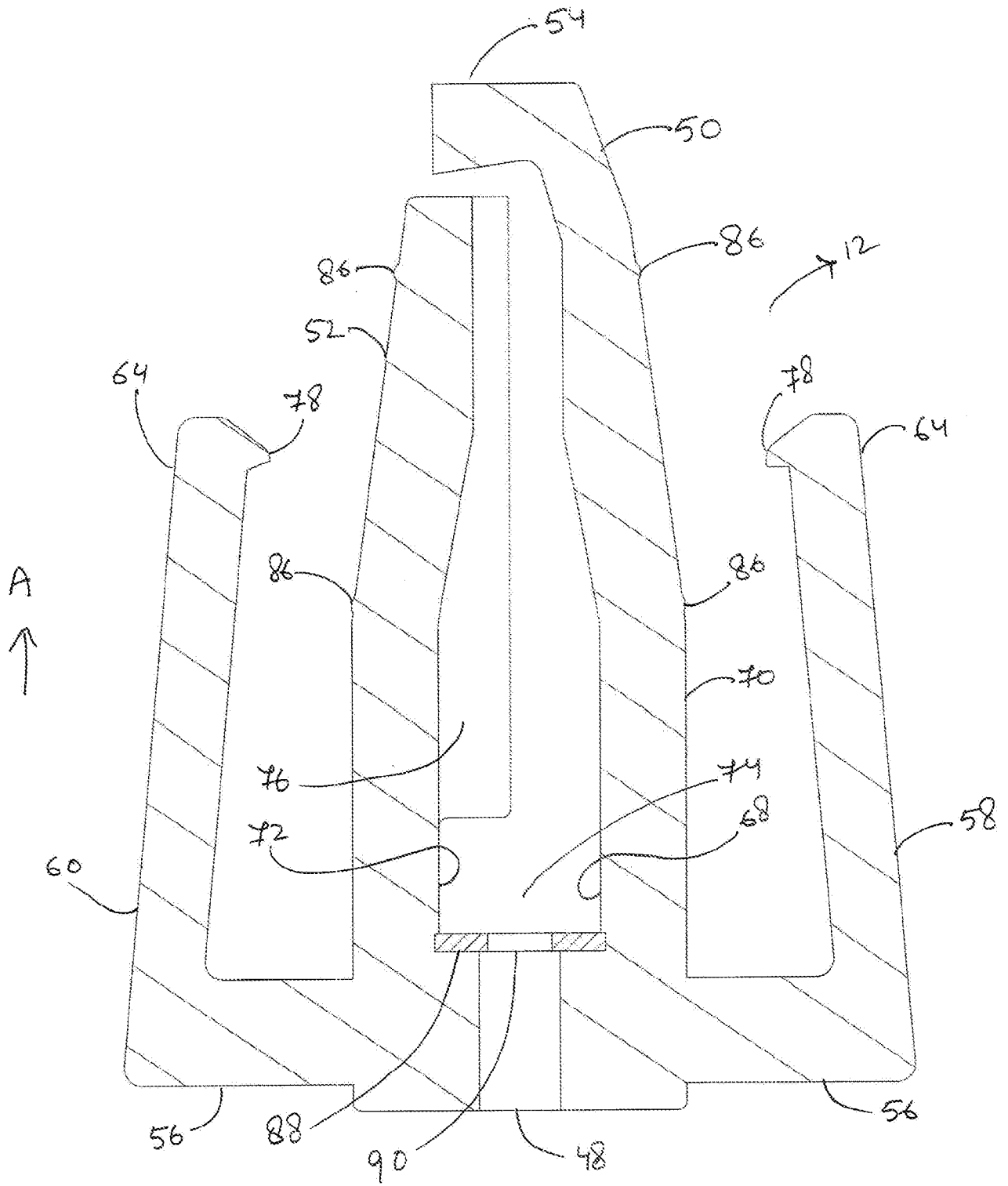

FIG. 5

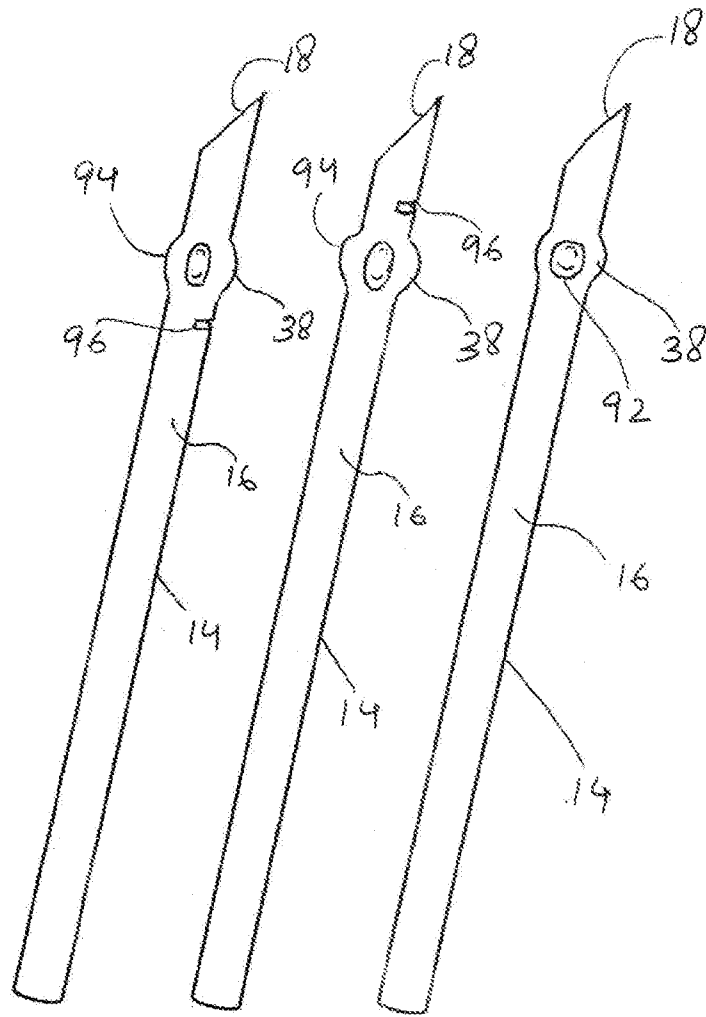

FIG. 6 A

FIG. 6 B

FIG. 6 C

INTERNATIONAL SEARCH REPORT

International application No

PCT/IB2012/053820

A. CLASSIFICATION OF SUBJECT MATTER

INV. A61M25/06

ADD.

According to International Patent Classification (IPC) or to both national classification and IPC

B. FIELDS SEARCHED

Minimum documentation searched (classification system followed by classification symbols)

A61M

Documentation searched other than minimum documentation to the extent that such documents are included in the fields searched

Electronic data base consulted during the international search (name of data base and, where practicable, search terms used)

EPO-Internal, WPI Data

C. DOCUMENTS CONSIDERED TO BE RELEVANT

Category*	Citation of document, with indication, where appropriate, of the relevant passages	Relevant to claim No.
X	EP 2 127 692 A1 (POLY MEDICURE LTD [IN]) 2 December 2009 (2009-12-02)	1,2,4-6, 9-17,20, 22
L	paragraph [0050] - paragraph [0066] figures 1,4,5	1,2,4-6, 9-17,20, 22
X	----- WO 2011/036574 A1 (POLY MEDICURE LTD [IN]; BAID RISHI [IN]) 31 March 2011 (2011-03-31) paragraph [0040]; figures 3,5	3,18,19
X	----- EP 1 297 859 A2 (ETHICON ENDO SURGERY INC [US] SMITHS MEDICAL ASD INC [US]) 2 April 2003 (2003-04-02) paragraphs [0016], [0022] figure 8	7
	----- -/--	



Further documents are listed in the continuation of Box C.



See patent family annex.

* Special categories of cited documents :

"A" document defining the general state of the art which is not considered to be of particular relevance

"E" earlier application or patent but published on or after the international filing date

"L" document which may throw doubts on priority claim(s) or which is cited to establish the publication date of another citation or other special reason (as specified)

"O" document referring to an oral disclosure, use, exhibition or other means

"P" document published prior to the international filing date but later than the priority date claimed

"T" later document published after the international filing date or priority date and not in conflict with the application but cited to understand the principle or theory underlying the invention

"X" document of particular relevance; the claimed invention cannot be considered novel or cannot be considered to involve an inventive step when the document is taken alone

"Y" document of particular relevance; the claimed invention cannot be considered to involve an inventive step when the document is combined with one or more other such documents, such combination being obvious to a person skilled in the art

"&" document member of the same patent family

Date of the actual completion of the international search

30 November 2012

Date of mailing of the international search report

07/12/2012

Name and mailing address of the ISA/

European Patent Office, P.B. 5818 Patentlaan 2
NL - 2280 HV Rijswijk
Tel. (+31-70) 340-2040,
Fax: (+31-70) 340-3016

Authorized officer

Berndorfer, Urs

INTERNATIONAL SEARCH REPORT

International application No
PCT/IB2012/053820

C(Continuation). DOCUMENTS CONSIDERED TO BE RELEVANT		
Category*	Citation of document, with indication, where appropriate, of the relevant passages	Relevant to claim No.
A	<p>WO 03/011381 A1 (DELTA MED S R L [IT]; VILLA DANILO [IT]; MINARI EMANUELE [IT]) 13 February 2003 (2003-02-13) page 15 - page 18 figures 7-12</p> <p align="center">-----</p>	1-22
E	<p>EP 2 517 751 A1 (TYCO HEALTHCARE [US]) 31 October 2012 (2012-10-31)</p> <p>paragraphs [0016], [0019] - [0024] figures 1-6</p> <p align="center">-----</p>	1,2,4, 6-9, 11-20,22
X,P	<p>WO 2011/154767 A1 (POLY MEDICURE LTD [IN]; BAID RISHI [IN]) 15 December 2011 (2011-12-15)</p> <p align="center">-----</p>	1,2,4-6, 9-17,20, 22
L	<p>the whole document</p> <p align="center">-----</p>	1,2,4-6, 9-17,20, 22

INTERNATIONAL SEARCH REPORT

Information on patent family members

International application No PCT/IB2012/053820

Patent document cited in search report	Publication date	Patent family member(s)	Publication date
EP 2127692	A1	02-12-2009	EP 2127692 A1 02-12-2009
			EP 2251056 A2 17-11-2010
			EP 2251057 A2 17-11-2010
			ES 2388246 T3 11-10-2012
			ES 2390025 T3 06-11-2012
			ES 2391140 T3 21-11-2012
			US 2009299291 A1 03-12-2009
			US 2011125096 A1 26-05-2011
WO 2011036574	A1	31-03-2011	AU 2010299500 A1 19-04-2012
			CN 102639180 A 15-08-2012
			EP 2470252 A1 04-07-2012
			US 2012232500 A1 13-09-2012
			WO 2011036574 A1 31-03-2011
EP 1297859	A2	02-04-2003	CA 2405331 A1 27-03-2003
			EP 1297859 A2 02-04-2003
			EP 1502621 A2 02-02-2005
			ES 2328794 T3 18-11-2009
			JP 4294929 B2 15-07-2009
			JP 2003180833 A 02-07-2003
			JP 2009056336 A 19-03-2009
			US 2003060771 A1 27-03-2003
WO 03011381	A1	13-02-2003	AT 346632 T 15-12-2006
			CN 1547493 A 17-11-2004
			DE 60216467 T2 27-09-2007
			DK 1412006 T3 02-04-2007
			EP 1412006 A1 28-04-2004
			ES 2276954 T3 01-07-2007
			HK 1067321 A1 24-08-2007
			IT B020010497 A1 31-01-2003
			JP 3790247 B2 28-06-2006
			JP 2004535905 A 02-12-2004
			PL 204005 B1 31-12-2009
			PT 1412006 E 30-03-2007
			RU 2276611 C2 20-05-2006
			US 2004225260 A1 11-11-2004
			WO 03011381 A1 13-02-2003
EP 2517751	A1	31-10-2012	EP 2517751 A1 31-10-2012
			US 2012277679 A1 01-11-2012
WO 2011154767	A1	15-12-2011	NONE