

R. TYHURST.
Smut Machine.

No. 5,627.

Patented June 13, 1848.

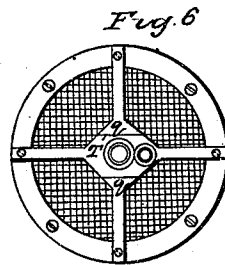
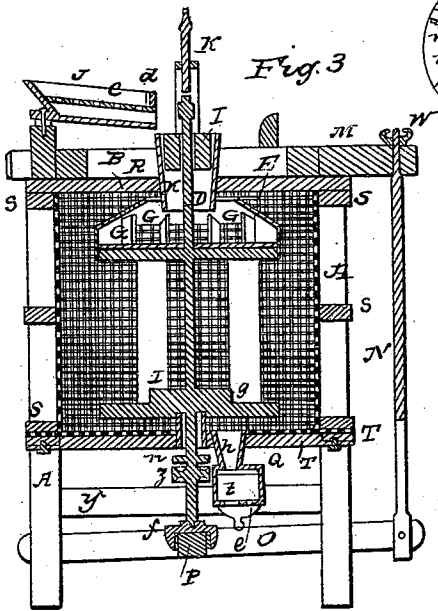
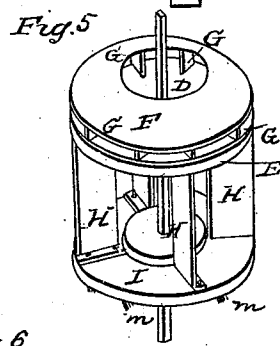
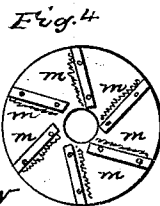
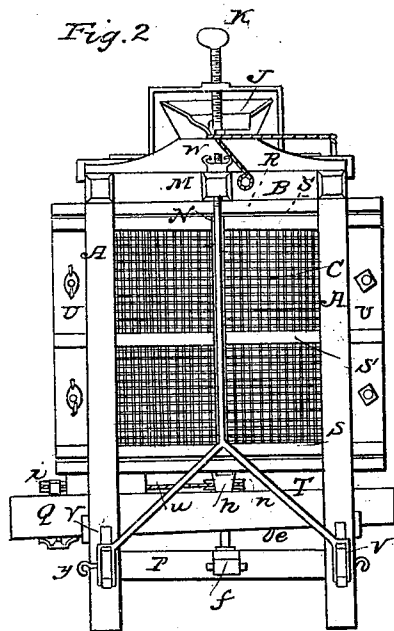
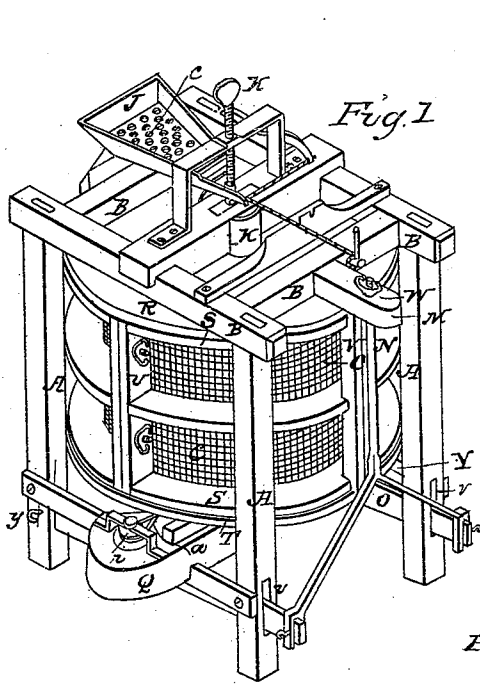

UNITED STATES PATENT OFFICE.

ROBERT TYHURST, OF PETERSBURG, NEAR SHAVERS CREEK P. O., PENNSYLVANIA.

SMUT-MACHINE.

Specification of Letters Patent No. 5,627, dated June 13, 1848.

To all whom it may concern:

Be it known that I, ROBERT TYHURST, of Petersburg, near Shavers Creek P. O., in the county of Huntingdon and State of Pennsylvania, have invented a new and Improved Smut-Machine for Separating Impurities from Wheat and other Grain and for Cleaning and Polishing the Kernels of the same; and I do hereby declare the following to be a full, clear, and exact description thereof, reference being had to the accompanying drawings, making a part of this specification, in which—

Figure 1, is a perspective view, Fig. 2, a side elevation, Fig. 3, a vertical section; and Figs. 4, and 5, are perspective views of parts of the machine detached. Fig. 6, is a plan of the under side of the beating chamber of the machine.

Similar letters refer to corresponding parts in all the figures.

The supporting frame of my improved smut machine may be constructed of corner posts A, A, and transverse pieces B, B, and Y, Y, as represented in the drawings, or in any other suitable manner. Within the supporting frame I secure a vertical cylindrical screen C; supported by the rings S, S, the clamps U, U, and standards V, V.

The screen C, rests upon the ring T, which is sustained by the fan box and spout Q, and the side pieces Y, Y, of the supporting frame. A horizontal screen x , closes the bottom of the vertical screen C, the edges of which are secured between the lower ring S, and the base ring T. A transverse piece T', passes under the center of the screen x , and is bolted to the under side of the base ring T.

q, q , (Fig. 6) are radial arms supporting the transverse piece T' under the screen x .

g , is a tube inserted in the transverse supporting piece T', passing up through the center of the screen x , in which revolves the shaft D, of the beater and scourer.

h , is a tube inserted through the transverse piece T', and the screen x , near its center, leading from the beating chamber, within the screen C, into the fan spout Q.

R, is the cap of the beating chamber, fitting on to the upper ring S, inclosing the top of the cylindrical screen C.

K, is a tube inserted into the center of the cap R, for the reception of the grain to be cleaned, and in which works the shaft D.

Within the cylindrical screen C, I place

the beater and scourer, or polisher, represented by Fig. 5; this is constructed as follows. To the shaft D, the upper and lower disks E, and I, are secured; these are connected and supported at their peripheries by the series of radial beaters H, H.

F, is a metallic dome shaped cap (having an aperture in its center) placed a short distance above the disk E, to which it is secured and connected, by the series of radial wings G, G.

To the under side of the disk I, there is secured a series of whale bone scouring and polishing brushes, placed at such an angle with the radii of the disk, as to draw the grain from the periphery toward the center of the same (as represented in Fig. 4).

The shaft D, has its bearing in the box f , which is secured to the adjustable beam P; the ends of the beam P, are let into and secured to the side pieces O, O. The tenons at one end of the side pieces O, O, are let into mortises in the corner posts of the supporting frame, and secured by joint pins y, y ; the tenons at their opposite ends, pass through the vertical slots v, v , in the opposite corner posts, and are connected to the branches of the forked metallic rod N, by which they are suspended.

The upper end of the forked rod N, passes through the projection M, let into and secured to one of the transverse timbers B, of the supporting frame; a screw is cut on the upper end of the suspension rod N, on which works the nut W, by means of which the shaft D, of the beater and scourer, is, raised and lowered, and the distance between the brushes m, m , and the bottom screen x , is adjusted.

The tube h , in the center of the cap piece R, of the beating chamber, passes down into the aperture in the cap F, of the beater and scourer, as seen in Fig. 3.

J, is the hopper in which the grain is placed to be operated on; in this is placed a coarse sieve c , for separating the trash from the grain, and preventing its passage into the beating chamber; the trash passes out through the lateral aperture d , above the sieve c ; the grain passes out of the spout of the hopper under the screen, into the tube h , which conducts it through the dome cap F, on to the disk E; from which it is thrown out by centrifugal force between the wings G, G, against the sides of the cylindrical screen C; from which it reacts against, and

is thoroughly operated upon, by the beaters G, G, and H, H, as it descends to the bottom of the beating chamber.

When the grain falls on to the horizontal screen *x*, the brushes *m, m*, draw it inward toward the center of the same into the discharging tube *h*. The friction exerted between the brushes *m, m*, and screen *x*, scours and polishes the kernels of grain, without breaking the same, and breaks up and pulverizes all impurities that may be in the grain. The tube *g*, surrounding the shaft D, rises a short distance through the screen *x*, and passes into a recess in the under side of the disk I, for the purpose of preventing the grain from being drawn into the tube *g*.

z, is the driving pulley on the lower portion of the shaft D; *n*, is a pulley on the shaft D, imparting motion to the pulley *i*, on the fan shaft, by means of the band *a*.

Immediately under the discharging tube *h*, there is an aperture *t*, in the lower side of the fan box Q, through which the grain is discharged from the smut machine, per-

fectly cleaned. In its passage from the tube *h*, to the discharging aperture *t*, in the under side of the fan spout, the blast of air from the fanner, separates every particle of dust and impurity from the grain.

e, is a gate in the fan spout, near the aperture *t*, for the purpose of regulating and concentrating the strength of the draft of air from the fanner, and for preventing any portion of the grain from being discharged at the outlet of the spout.

Having thus fully described the construction and operation of my improved smut machine, what I claim therein as new and desire to secure by Letters Patent, is—

The combination of the series of scouring and polishing brushes *m, m*, with the horizontal screen *x*, at the base of the beating chamber, substantially in the manner and for the purpose herein set forth.

ROBERT TYHURST.

Witnesses:

JOHN BORST,
JOHN NEFF.