



(11) **EP 3 521 745 B1**

(12) **EUROPEAN PATENT SPECIFICATION**

(45) Date of publication and mention of the grant of the patent:
05.10.2022 Bulletin 2022/40

(51) International Patent Classification (IPC):
F28F 1/40 ^(2006.01) **F28F 3/02** ^(2006.01)
F28F 1/02 ^(2006.01) **F28D 1/03** ^(2006.01)
F28D 1/053 ^(2006.01)

(21) Application number: **18461515.1**

(52) Cooperative Patent Classification (CPC):
F28F 1/02; F28D 1/0391; F28D 1/05366;
F28F 1/40; F28F 3/025; F28D 2021/008

(22) Date of filing: **06.02.2018**

(54) **A FLAT TUBE ASSEMBLY FOR A HEAT EXCHANGER**

FLACHROHRANORDNUNG FÜR EINEN WÄRMETAUSCHER

ENSEMBLE AILETTE ET TUBE PLAT D'UN ÉCHANGEUR DE CHALEUR

(84) Designated Contracting States:
AL AT BE BG CH CY CZ DE DK EE ES FI FR GB GR HR HU IE IS IT LI LT LU LV MC MK MT NL NO PL PT RO RS SE SI SK SM TR

- **MATYSZKOWICZ, Wojciech**
32-050 Skawina (PL)
- **LACHOWICZ, Przemyslaw**
32-050 Skawina (PL)

(43) Date of publication of application:
07.08.2019 Bulletin 2019/32

(74) Representative: **Valeo Systèmes Thermiques**
Service Propriété Intellectuelle
ZA l'Agiot, 8 rue Louis Lormand
CS 80517
La Verrière
78322 Le Mesnil-Saint-Denis Cedex (FR)

(73) Proprietor: **Valeo Autosystemy SP. Z.O.O.**
32-050 Skawina (PL)

(72) Inventors:

- **KOLACZ, Adam**
32-050 Skawina (PL)
- **BIENIEK, Robert**
32-050 Skawina (PL)

(56) References cited:
EP-A1- 3 040 669 **DE-A1-102007 033 177**
DE-A1-102008 013 018 **DE-A1-102012 211 350**
GB-A- 2 324 145 **JP-U- H0 552 563**

EP 3 521 745 B1

Note: Within nine months of the publication of the mention of the grant of the European patent in the European Patent Bulletin, any person may give notice to the European Patent Office of opposition to that patent, in accordance with the Implementing Regulations. Notice of opposition shall not be deemed to have been filed until the opposition fee has been paid. (Art. 99(1) European Patent Convention).

Description

FIELD OF THE INVENTION

[0001] The invention relates to a tube assembly for a heat exchanger. More particularly, the present invention relates to a tube assembly with a flat tube and a corrugated fin for a heat exchanger used in the automotive industry.

BACKGROUND OF THE INVENTION

[0002] In known heat exchangers, for example those used in the automotive industry, the heat exchange can take place between two fluids. The first fluid can be guided through a conduit formed by elements of the heat exchanger. These can be two manifolds connected fluidically by means of tubes. One of the fluids travels through these tubes between said manifolds. There can be spaces provided between the tubes, through which the second fluid can travel from one side of the tubes to the other. The tubes conduct the heat of the first fluid which is then transferred to the second fluid, or vice versa.

[0003] There are known flat tubes, which in cross-section have an elongated shape defined by two parallel walls connected at their side edges by side walls of substantially smaller height. These tubes are generally placed one above the other so that their neighboring flat, parallel walls form channels for the second fluid. The tubes can comprise inner fins, for example in form of corrugated sheets, the bent portions of which are in contact with said flat parallel walls of the flat tubes. These fins facilitate the heat exchange. The example of such tubes is described in patent applications with publication numbers EP1089047A2 and EP1906127A2. DE 10 2008 013 018 A1 describes a flat tube assembly according to the preamble of claim 1.

[0004] However, for the fins commonly used in the industry, the process of successfully filling the inner channel of the flat tube is complicated. In particular, a uniform distribution of the corrugated sheet in the flat tube poses difficulties which are hard to overcome in a cost-efficient manner. This is especially the case with flat tubes in which the side walls and their corner portions between the parallel flat walls and said side walls are made of layered tube material. In other words, the material thickness of the flat tube, due to its layered structure in those areas, varies towards its inner side, thereby hindering the uniformity of the fins distribution within the tube. For example, if the tube wall thickness is greater in the corner section in which normally the last wall portion of the fin of normal height would terminate, this last wall portion is made shorter. In other cases, the fin terminates at the last bent portion. In most cases this creates a space by the side wall of the tube which is unoccupied by the fin. This space creates a so called air bypass. The bypass does not contribute to the heat exchange in a manner similar to the rest of the flat tube.

[0005] It is thus the aim of the invention to improve operation of the flat tube assembly comprising a flat tube and a fin inside said tube, and in particular to improve the heat exchange capabilities of the flat tube assembly. It is aimed to achieve this effect in a cost efficient manner which would be easy to implement.

SUMMARY OF THE INVENTION

[0006] The object of the invention is flat tube assembly for a heat exchanger, as defined by claim 1, comprising a flat tube and a fin placed inside the tube, the flat tube being formed by a sheet material and being defined by a bottom wall, a top wall and two side walls, the distance between the bottom wall and the top wall defining the height direction H with tube height H_t , and the distance between the side walls defining the width direction W, wherein at least one of the side walls and a corner section between the bottom wall and this side wall are formed by layers of the sheet material, and wherein the fin is a corrugated sheet with plurality of adjacent walls joined at top and bottom bent portions which are in contact with the top and bottom walls of the tube respectively, the adjacent bent portions being distanced from each other by substantially constant distance T1, wherein a terminal adjacent wall of the fin has a bottom side edge which is distanced from the adjacent bottom bent portion, along the width direction W, by a distance T2 which is bigger than distance T1, and is distanced from the top wall, along the height direction H, by a distance H_f which is smaller than H_t .

[0007] Preferably, the bottom side edge of the terminal adjacent wall of the fin is in contact with the side wall of the flat tube.

[0008] The terminal adjacent wall has a bent portion so that the terminal adjacent wall runs substantially in parallel to the side wall, in a distanced manner, between said bent portion and the bottom side edge.

[0009] Preferably, the bent portion is located closer to the last top bent portion than to the bottom side edge.

[0010] Preferably, the distance H_f between the bottom side edge and the top wall is 6 mm, while the distance H_t between the bottom wall and the top wall is 7 mm.

[0011] Preferably, the distance T2 between the bottom side edge and the adjacent bottom bent portion is 4,5 mm, while the distance T1 between the adjacent bottom end portions 22 is 2,5 mm.

BRIEF DESCRIPTION OF DRAWINGS

[0012] Examples of the invention will be apparent from and described in detail with reference to the accompanying drawings, in which:

Figs. 1a and 1b show a tube assembly according to the invention.

DETAILED DESCRIPTION OF EMBODIMENTS

[0013] Figs. 1a and 1b show a tube assembly according to the invention. It is to be noted that both these figures present the same tube assembly - the same embodiment is presented twice to provide space for reference signs in a clear manner. The description thus relates to both these figures interchangeably.

[0014] The figures show a flat tube assembly 1 for a heat exchanger. The heat exchanger can be a charge air cooler, water charge air cooler, condenser, radiator and the like. The flat tube assembly 1 comprises a flat tube 10 and a fin 20 placed inside the tube 10. The flat tube 10 is formed by a sheet material and is defined by a bottom wall 11, a top wall 12 and two side walls 13. The side walls can be completely arcuate or can comprise a flat middle section. The distance between the bottom wall 11 and the top wall 12 defines the height direction H. Tube height H_t is measured along this distance. In other words, tube height H_t is the shortest distance between the flat, parallel walls 11, 12 of the flat tube. On the other hand, the distance between the side walls 13 defines the width direction W. This width direction is to be understood to run parallel to the flat, parallel walls 11, 12.

[0015] At least one of the side walls 13 and a corner section 14 between the bottom wall 11 and this side wall 13 are formed by layers of the sheet material. In particular, when the tube is produced from a single material sheet which is bent into the flat tube shape, the sides of the sheet overlap one onto the other at one of the sides. Consequently, at least one of the side walls have a layered structure. Similarly, at least one of the corner sections at the joint between bottom wall and a side wall will also be layered.

[0016] The fin 20 is a corrugated sheet comprising a plurality of adjacent walls joined at top and bottom bent portions 22 which are in contact with the top and bottom walls 11, 12 of the tube 10 respectively. The top and bottom bent portions 22 form ridges of the folds which form corrugations. The adjacent bent portions 22 are distanced from each other by substantially constant distance T1, which means that the neighboring bottom bent portions are separated from each other by the distance T1, and the neighboring top bent portions are also separated from each other by the distance T1.

[0017] A terminal adjacent wall 21 of the fin 20, that is the last wall of the corrugated sheet in the width direction W, has a bottom side edge 23. This bottom side edge 23 is the terminal part of the terminal adjacent wall. The bottom side edge 23 is distanced from the adjacent bottom bent portion 22, along the width direction W, by a distance T2 which is bigger than distance T1. At the same time, it is distanced from the top wall 12, along the height direction H, by a distance H_f which is smaller than H_t . By the adjacent bottom bent portion 22, from which the distance T2 is measured, it is understood the last bent portion on the same side of the tube as the bottom side edge

23. This enables saving of the material and utilizing an alternative, simplified process method. The fin 20 attachment to the tube 10 is also more secure. Such configuration enables the fin 20 to be more evenly distributed in such flat tube with layered side wall.

[0018] The bottom side edge 23 of the terminal adjacent wall 21 of the fin 10 may be in contact with the side wall 13 of the flat tube 10, preferably connected permanently to it.

[0019] The terminal adjacent wall 21 can comprise a bent portion 24, as shown in Figs. 1a and 1b. This bent portion 24 is located between the last top bent portion 22 and the bottom side edge 23, preferably closer to the former. The bent portion 24 is shaped so that the terminal adjacent wall 21 runs substantially in parallel to the side wall 13, in a distanced manner, between said bent portion 24 and the bottom side edge 23. In other words, the general shape of the side wall 13 is followed in a substantially parallel manner by the general shaper of the terminal adjacent wall 21. This enhances the uniform distribution of the fin within the tube and reduces to a greater extent, and with appropriately chosen distancing - possibly eliminates, the air by-pass.

[0020] In a preferable embodiment, the distance H_f between the bottom side edge 23 and the top wall 11 may be 6 mm, while the distance H_t between the bottom wall 11 and the top wall 12 may be 7 mm.

[0021] For the tube of the above-mentioned dimensions, the distance T2 between the bottom side edge 23 and the adjacent bottom bent portion 22 may be 4,5mm, while the distance T1 between the adjacent bottom end portions 22 may be 2,5 mm.

[0022] It is to be understood that both side walls and their respective corner sections can have a layered structure. The structure of the end wall of the fin will then apply analogously to both sides, with a logical adaptation of dependencies between elements denoted as 'top' elements and 'bottom' elements.

[0023] Other variations to the disclosed embodiments can be understood and effected by those skilled in the art in practicing the claimed invention, from a study of drawings, the disclosure, and the appended claims. The mere fact that certain measures are recited in mutually different dependent claims does not indicate that a combination of these measures cannot be used to the advantage.

Claims

1. A flat tube assembly 1 for a heat exchanger, comprising a flat tube 10 and a fin 20 placed inside the tube 10, the flat tube 10 being formed by a sheet material and being defined by a bottom wall 11, a top wall 12 and two side walls 13, the distance between the bottom wall 11 and the top wall 12 defining the height direction H with tube height H_t , and the distance between the side walls 13 defining the width

direction W, wherein at least one of the side walls 13 and a corner section 14 between the bottom wall 11 and this side wall 13 are formed by layers of the sheet material, and wherein the fin 20 is a corrugated sheet with plurality of adjacent walls joined at top and bottom bent portions 22 which are in contact with the top and bottom walls 11, 12 of the tube 10 respectively, the adjacent bent portions 22 being distanced from each other by substantially constant distance T1, wherein a terminal adjacent wall 21 of the fin 10 has a bottom side edge 23 which is distanced from the adjacent bottom bent portion 22, along the width direction W, by a distance T2 which is bigger than distance T1, and is distanced from the top wall 12, along the height direction H, by a distance Hf which is smaller than Ht, **characterized in that** the terminal adjacent wall 21 has a bent portion 24 so that the terminal adjacent wall 21 runs substantially in parallel to the side wall 13, in a distanced manner, between said bent portion 24 and the bottom side edge 23.

2. A flat tube assembly according to claim 1, wherein the bottom side edge 23 of the terminal adjacent wall 21 of the fin 10 is in contact with the side wall 13 of the flat tube 10.
3. A flat tube according to any preceding claim, wherein the bent portion 24 is located closer to the last top bent portion 22 than to the bottom side edge 23.
4. A flat tube according to any preceding claim, wherein the distance Hf between the bottom side edge 23 and the top wall 11 is 6 mm, while the distance Ht between the bottom wall 11 and the top wall 12 is 7 mm.
5. A flat tube according to any preceding claim, wherein the distance T2 between the bottom side edge 23 and the adjacent bottom bent portion 22 is 4,5 mm, while the distance T1 between the adjacent bottom end portions 22 is 2,5 mm.

Patentansprüche

1. Flachrohranordnung 1 für einen Wärmetauscher, mit einem Flachrohr 10 und einer im Inneren des Rohres 10 angeordneten Rippe 20, wobei das Flachrohr 10 aus einem Blechmaterial gebildet und durch eine untere Wand 11, eine obere Wand 12 und zwei Seitenwände 13 begrenzt ist, wobei der Abstand zwischen der unteren Wand 11 und der oberen Wand 12 die Höhenrichtung H mit der Rohrhöhe Ht definiert und der Abstand zwischen den Seitenwänden 13 die Breitenrichtung W definiert, wobei mindestens eine der Seitenwände 13 und ein Eckabschnitt 14 zwischen der unteren Wand 11 und dieser Seitenwand

13 durch Schichten des Blechmaterials gebildet werden, und wobei die Rippe 20 ein gewelltes Blech mit einer Vielzahl von angrenzenden Wänden ist, die an oberen und unteren gebogenen Abschnitten 22 verbunden sind, die die Ober- bzw. untere Wand 11, 12 des Rohrs 10 berühren, wobei die angrenzenden gebogenen Abschnitte 22 um einen im Wesentlichen konstanten Abstand T1 voneinander beabstandet sind, wobei eine angrenzende Endwand 21 der Rippe 10 eine untere Seitenkante 23 aufweist, die von dem angrenzenden unteren gebogenen Abschnitt 22 entlang der Breitenrichtung W um einen Abstand T2 beabstandet ist, der größer als der Abstand T1 ist, und von der oberen Wand 12 entlang der Höhenrichtung H um einen Abstand Hf beabstandet ist, der kleiner als Ht ist, **dadurch gekennzeichnet, dass** die angrenzende Endwand 21 einen gebogenen Abschnitt 24 aufweist, sodass die angrenzende Endwand 21 im Wesentlichen parallel zur Seitenwand 13 beabstandet zwischen dem gebogenen Abschnitt 24 und der unteren Seitenkante 23 verläuft.

2. Flachrohranordnung gemäß Anspruch 1, wobei die untere Seitenkante 23 der angrenzenden Endwand 21 der Rippe 10 die Seitenwand 13 des Flachrohrs 10 berührt.
3. Flachrohr gemäß einem der vorhergehenden Ansprüche, wobei der gebogene Abschnitt 24 näher an dem letzten oberen gebogenen Abschnitt 22 als an der unteren Seitenkante 23 angeordnet ist.
4. Flachrohr gemäß einem der vorhergehenden Ansprüche, wobei der Abstand Hf zwischen der unteren Seitenkante 23 und der oberen Wand 11 7 mm beträgt, während der Abstand Ht zwischen der unteren Wand 11 und der oberen Wand 12 6 mm beträgt.
5. Flachrohr gemäß einem der vorhergehenden Ansprüche, wobei der Abstand T2 zwischen der unteren Seitenkante 23 und dem angrenzenden unteren gebogenen Abschnitt 22 2,5 mm beträgt, während der Abstand T1 zwischen den angrenzenden unteren Endabschnitten 22 4,5 mm beträgt.

Revendications

1. Ensemble ailette et tube plat 1 pour échangeur de chaleur, comprenant un tube plat 10 et une ailette 20 placée à l'intérieur du tube 10, le tube plat 10 étant formé par un matériau en feuille et étant défini par une paroi inférieure 11, une paroi supérieure 12 et deux parois latérales 13, la distance entre la paroi inférieure 11 et la paroi supérieure 12 définissant la direction de la hauteur H avec la hauteur du tube Ht, et la distance entre les parois latérales 13 définissant la direction de la largeur W, au moins l'une des parois

latérales 13 et une section de coin 14 entre la paroi inférieure 11 et cette paroi latérale 13 étant formées par des couches du matériau en feuille, et l'aillette 20 étant une feuille ondulée avec une pluralité de parois adjacentes jointes à des parties pliées supérieure et inférieure 22 qui sont en contact avec les parois supérieure et inférieure 11, 12 du tube 10 respectivement, les parties pliées 22 adjacentes étant espacées les unes des autres d'une distance sensiblement constante T1, une paroi adjacente terminale 21 de l'aillette 10 ayant un bord latéral inférieur 23 qui est espacé de la partie pliée inférieure 22 adjacente, dans le sens de la largeur W, d'une distance T2 qui est supérieure à la distance T1, et est espacé de la paroi supérieure 12, dans le sens de la hauteur H, d'une distance Hf qui est inférieure à Ht, **caractérisé en ce que** la paroi adjacente terminale 21 a une partie pliée 24 de sorte que la paroi adjacente terminale 21 s'étende sensiblement parallèlement à la paroi latérale 13, d'une manière espacée, entre ladite partie pliée 24 et le bord latéral inférieur 23.

2. Ensemble ailette et tube plat selon la revendication 1, le bord latéral inférieur 23 de la paroi adjacente terminale 21 de l'aillette 10 étant en contact avec la paroi latérale 13 du tube plat 10.
3. Tube plat selon l'une quelconque des revendications précédentes, la partie pliée 24 étant située plus près de la dernière partie pliée supérieure 22 que du bord latéral inférieur 23.
4. Tube plat selon l'une quelconque des revendications précédentes, la distance Hf entre le bord latéral inférieur 23 et la paroi supérieure 11 étant de 7 mm, tandis que la distance Ht entre la paroi inférieure 11 et la paroi supérieure 12 est de 6 mm.
5. Tube plat selon l'une quelconque des revendications précédentes, la distance T2 entre le bord latéral inférieur 23 et la partie pliée inférieure 22 adjacente étant de 2,5 mm, tandis que la distance T1 entre les parties d'extrémité inférieures 22 adjacentes est de 4,5 mm.

45

50

55

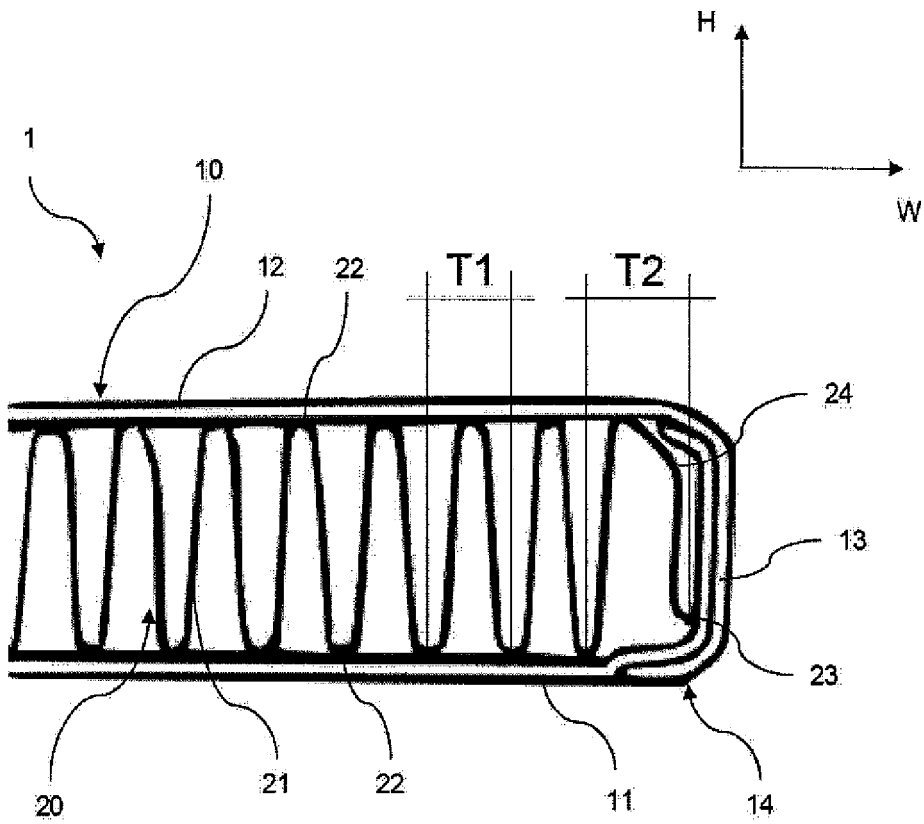

Fig. 1a

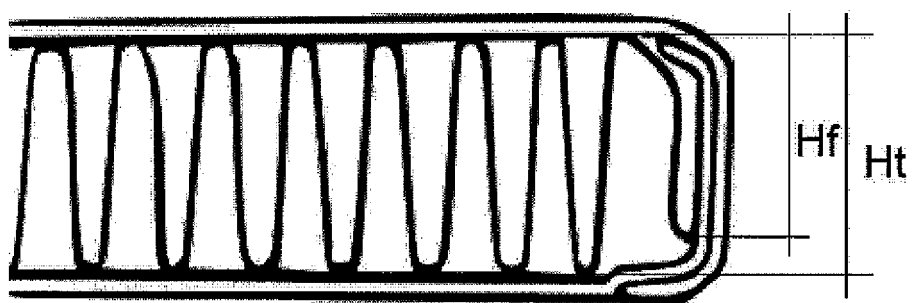

Fig. 1b

REFERENCES CITED IN THE DESCRIPTION

This list of references cited by the applicant is for the reader's convenience only. It does not form part of the European patent document. Even though great care has been taken in compiling the references, errors or omissions cannot be excluded and the EPO disclaims all liability in this regard.

Patent documents cited in the description

- EP 1089047 A2 [0003]
- EP 1906127 A2 [0003]
- DE 102008013018 A1 [0003]