

H. GRISWOLD.
 VAPOUR LAMP BURNER.
 APPLICATION FILED AUG. 21, 1899.

960,168.

Patented May 31, 1910.

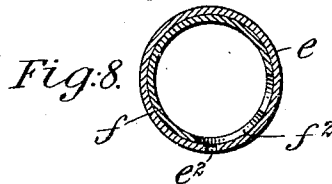
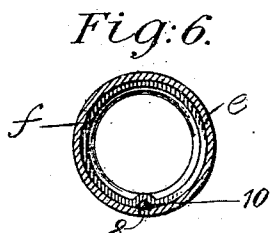
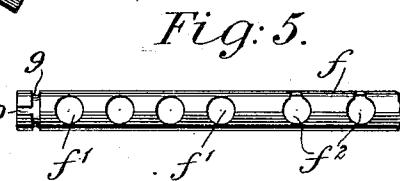
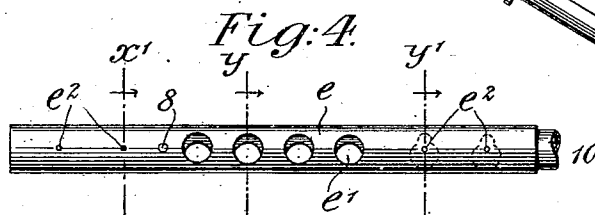
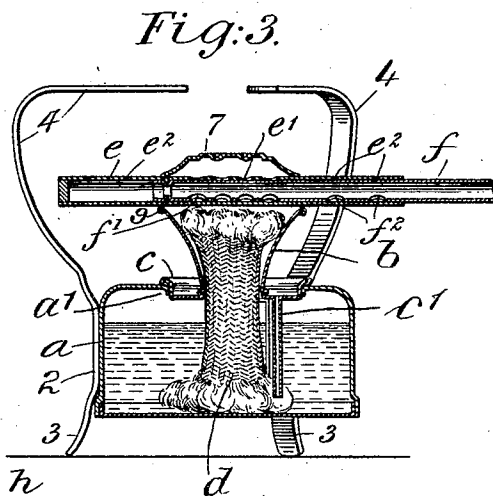
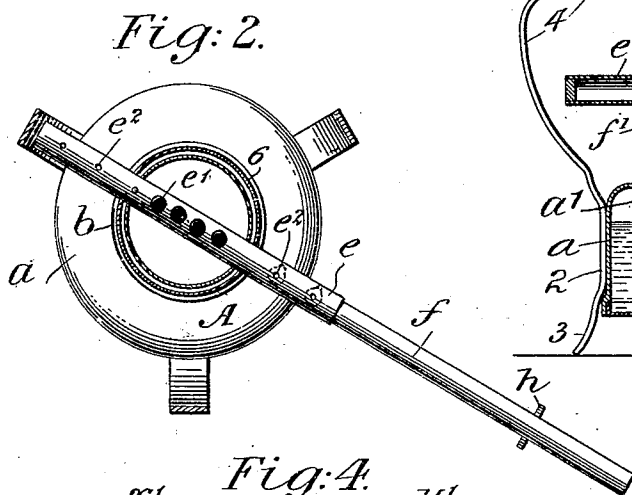
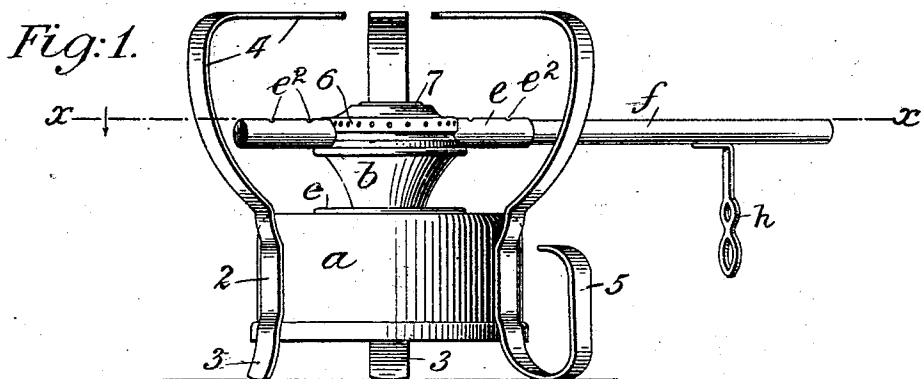

Witnesses:
A. D. S. Smith
Chas. Smith

Inventor:
Harrison Griswold
 By *Harold Terrell*

his Attorney.

UNITED STATES PATENT OFFICE.

HARRISON GRISWOLD, OF NEW YORK, N. Y.

VAPOR-LAMP BURNER.

960,168.

Specification of Letters Patent. Patented May 31, 1910.

Application filed August 21, 1909. Serial No. 513,942.

To all whom it may concern:

Be it known that I, HARRISON GRISWOLD, a citizen of the United States of America, residing in the borough of Manhattan, city, county, and State of New York, have invented an Improvement in Vapor-Lamp Burners, of which the following is a specification.

My invention relates to a vapor lamp burner having a stationary wick and preferably using alcohol as a burning fluid; such vapor lamps as are usually employed for heating and cooking.

In lamps of this character it has heretofore been difficult if not quite impossible to control the height of the flame, or in other words, to control the surplus vapor accumulated in the burner from the vaporization of the fluid in the presence of heat; it being a fact that the vapor frequently burned fiercely, increasing the size of the flame often to the danger point, all of which it is the object of my invention to overcome.

In carrying out my invention, I employ devices adjustable in character providing for the discharge of any surplus vapor accumulated in the body of the burner at places at opposite sides of the burner so that the escaping vapor does not add to the volume of the flame but may either escape or burn as small flames at the places of escape. This I accomplish by the movement of telescoping tubes, the outer one of which passes through and is secured to the burner body above the stationary wick and at the respective ends projects beyond the burner body. This tube is closed at one end and open at the other end to receive the interior tube.

The outer tube is provided with a series of large holes within the limits of the burner body and with several small holes in each of the respective projecting ends. The interior telescoping tube is open at the inner end and may be closed at the outer end. This tube is provided with holes that may be brought into coincidence with the holes of the outer tube within the body of the burner and with other holes that may be employed to open up or close off the small holes at one end of the outer tube, all of which is hereinafter more particularly described.

The device of my present invention as employed in this application is a restricted and specific form of the device the broader

features of which are illustrated, set forth and claimed in my application Serial #513,941, filed August 21, 1909.

In the drawing, Figure 1 is an elevation representing the device of my improvement. Fig. 2 is a sectional plan of the same at about the dotted line x , x of Fig. 1. Fig. 3 is a central vertical section and partial elevation of the burner as indicated in Figs. 1 and 2. Fig. 4 is a detached plan of the outer and a part of the inner telescoping tube. Fig. 5 is a detached view of the inner telescoping tube at one end. Figs. 6, 7 and 8 are cross sections through the telescoping tubes respectively on the dotted lines x^1 , y , and y^1 of Fig. 4.

a represents the cylindrical reservoir for fluid having a central opening and downturned flange a^1 . Support members are provided for the reservoir for holding the same slightly above the line of support and these each comprises a part 2 secured to the side of the reservoir, legs 3 depending from the reservoir to a point of support and arms 4 rising above the reservoir and bent over into a common plane for the support of a vessel placed thereon to be heated by the flame of the burner. One of the legs 3 I prefer to turn up as a handle 5 by which the device may be carried about.

b represents the burner and c a dishing-cover secured thereto at the lower end and provided with a flange which fits the flange a^1 of the reservoir. Depending from this cover is a tube c^1 the opening of which passes through the cover and the tube down into the fluid of the reservoir.

6 and 7 represent holes in the burner.

d represents the wick which is secured to the burner in a stationary manner.

e and f represent the outer and inner telescoping tubes. The outer tube as shown particularly in Figs. 1, 2 and 3 extends across through the burner and projects at its ends about equally on each side of the burner. This tube is provided with holes of large area within the limits of the burner and with small holes e^2 which come outside of the limits of the burner between the same and the respective ends of the tube. The inner tube f is open at the inner end and may be closed at the outer free end and it is provided with a finger-grip h for effecting its rotary movement. This inner tube is pro-

vided with large holes f^1 which are adapted to be brought into coincidence with the large holes e^1 of the tube e so as in the operation of the device to permit the surplus vapor
 5 within the burner passing through both sets of holes into the inner tube. This inner tube is also provided with large holes f^2 which are adapted in the turning of the tube f to be brought into coincidence with or to close off
 10 the holes e^2 at the right hand end of the tube e .

I have shown and prefer to employ a pin 8 secured in the tube e and projecting within and to make the open end of the inner tube f
 15 with a circumferential groove 9 and an entrance groove 10. Therefore when the tube f is passed into the tube e it stops short of the left hand holes e^2 and against the pin 8 and when turned the pin 8 passes into the groove
 20 10 and then into the groove 9, and in this position the parts are connected so as to prevent the accidental removal of the tube f but permit its free rotation.

In view of the fact that the inner end of the tube f is open at all times any surplus vapor can the moment that the holes e^1 and f^1 are brought into any form of opposition so as to provide a passageway, serve for the escape of the surplus vapor therethrough
 30 and when these holes are not in opposition the escape will be through the open end of the tube f and through the small holes e^2 at the left hand end of the tube e Fig. 4, and the escape through the small holes e^2 at the
 35 right hand end of the tube e Fig. 4 may be opened up without opening up the escape through the holes e^1 and f^1 . The escaping vapor through the holes e^2 may be in such small quantities in relieving internal pressure as not to be noticeable and not to establish flames of burning gas at these small openings; the vapor then escaping into the atmosphere but the force may be so great as to cause the escaping vapor to burn at these holes, therefore four small flames will be established which will not be large enough to interfere with handling the vapor burner or reservoir or to cause any effect in the heating of any vessel that may be placed on
 40 the arms 4.
 45 50

The extent to which the inner tube f is rotated in relation to the outer tube e determines whether the openings e^1 shall be entirely closed off or partially or wholly
 55 opened up in proportion to the juxtaposed relation of the openings e^1 and f^1 or lack thereof.

I claim as my invention:

1. The combination with a fluid reservoir, a burner and a stationary wick, of telescoping tubes, the outer one passing across through the burner and projecting beyond the same at the respective ends and provided with a series of holes within the limits
 60 of the burner, the inner tube being revoluble
 65

in its relation to the outer tube and removable and being provided with a series of holes adapted to be brought into coincidence with the holes of the outer tube within the limits of the burner, and means providing
 70 when said holes are brought into coincidence for the escape of surplus vapor from within the reservoir.

2. The combination with a fluid reservoir, a burner and a stationary wick, of telescoping tubes, the outer one passing across through the burner and projecting beyond the same at the respective ends and provided with a series of holes within the limits of the burner, the inner tube being revoluble
 80 in its relation to the outer tube and removable and being provided with a series of holes adapted to be brought into coincidence with the holes of the outer tube within the limits of the burner, the outer tube being
 85 provided with small holes outside of the limits of the burner and closed at one end, and the inner tube open at one end and provided with holes adapted to coincide with some of the small holes of the outer tube. 90

3. The combination with a fluid reservoir, a burner and a stationary wick, of telescoping tubes, the outer one passing across through the burner and projecting beyond the same at the respective ends and provided
 95 with a series of holes within the limits of the burner, the inner tube being revoluble in its relation to the outer tube and removable and being provided with a series of holes adapted to be brought into coincidence
 100 with the holes of the outer tube within the limits of the burner, means providing when said holes are brought into coincidence for the escape of surplus vapor from within the reservoir, the outer tube having a small pin
 105 projecting within the tube and the inner tube at its open end provided with a circumferential groove and an entrance groove thereto, the said inner tube being thus adapted to receive said pin and be remov-
 110 ably interlocked with said outer tube.

4. In a vapor lamp burner, the combination with a reservoir, supports therefor, a burner, a dish-cover for the reservoir secured to the burner and a stationary wick, of a tube
 115 passing transversely across through the burner, the one end closed and the other end open, said tube having a series of large holes therein within the limits of the burner and small holes therein outside the limits
 120 of the burner and in the upper part thereof in a spaced apart relation, a tube adapted to be received within the aforesaid tube, open at its inner end and closed at its outer end, and a finger-grip secured to said inner tube
 125 as a means for turning the same, a pin in the outer tube, a circumferential groove and entrance groove in the inner end of the inner tube adapted to receive said pin, permitting the rotation of the inner tube, said
 130

inner tube also having a series of perforations within the limits of the burner adapted to be brought into coincidence with the series of holes in the outer tube, and other
5 holes in the inner tube also adapted to be brought into coincidence by the turning of the inner tube with the small openings in the outer tube at one end thereof, whereby

the pent up vapors within the burner may escape in a regulatable manner.

Signed by me this 17th day of August 1909.

HARRISON GRISWOLD.

Witnesses:

GEO. T. PINCKNEY,

E. ZACHARIASEN.