

1 , 1 2 1 1 ;

1 ; 1 1 1 2 2 1 ;

1 2 2 (description) 가 ; 가 가

1 . ,

1

< >

< >

32 , 2000 7 21 가 60/220,030 2000 7 21 가 60/220,0
 IP

가 가 가 가

(DSS : Digital satellite services), TV, VCR, (DBSS: Direct broadcast satellit

, 가 (Task) 가

. VCR TV 가

가 , 가 가 가

가 가 가

가 가

가 (VCR), (DVD) CD (TV), (CD)

가 가 가 가 가 가 가 가

VCR VCR TV 가 TV TV VCR

(Task)

ace) / (Central/singular) (UI: User interf

가 가 UI 가 UI 가 UI 가 UI

(Builder tool) (Look and feel) (e-business)

(, 1394) (, 1394)

2 1 2 1 2 1 2 1 2 1

(a) 가 ; (b) 가 ; (c) 가 ; (d) 가 ; (e) 가

(description) 가 ; (d) 가 ; (e) 가

가 1 가 2 가 1 가 1 가 1

가 , 1 가 1
 ; 가 가 , 1
 ; 가 ; 가 , 1
 ; ; 가 1 가 ,
 가 ; ; 가 ; 가 ,
 ; ; 가 가 ; 가 .

1
 2
 3 가
 4a DTV
 DVCR
 4b
 5 6 - GUI
 7
 8 IP 1394 -1394
 9a 9c
 10 9a 9c
 11 9a 9c
 12 HTML
 13 12 - GUI
 14 IP 1394 -1394
 15
 16 HTML
 (RIC)
 17 가 RIC
 18 RIC IP
 19 17
 20 18
 21 , RIC

22

23a 23d 22

24a 24c - (-) 22

m (1 4 , (1) - (250)(1); (2) Background.htm (2); Icon.ht
 3); (4) Name.htm (4)
 5 12 , 12 13
 GUI htm :
 5 - TLNUID(index.htm)
 6 - background.htm
 7 - icon.htm
 8 - name.htm
 9 - logoicon1.htm
 10 - logoname1.htm
 11 - logoicon2.htm
 12 - logoname2.htm
 13
 14
 15, 6, 7, 8, 16, 17, 18, 19 가
 13 16 GUI HTM ,
 15 - TLNUID(index.htm)
 16 - logoicon1.htm
 17 - logoname1.htm
 18 - logoicon2.htm
 19 - logoname2.htm
 20 - ;
 21 - background.htm ;
 22 - icon.htm ;
 23 - name.htm , 가 ,

< >
 1 , (10) (12) (16)
 (14) (Multiple) (11) (16)
 가 () 1394
 1394 (Time-multiplexed) / (A/V)
 (IP: Internet protocol) (, IETF RFC 2734)
 IP , IEC61883 (Protocol)
 (FCP : Function control protocol),

4) (12) (10) (14) (14) (12) , (1)
 (10) , (14), (12) 가
 (12)
 Graphical user interface)(18) (14) (GUI :
 (20)
 (14) , (12)
 (10) , (12)
 (12) , (14) (Sourcing/Sinking) (12)
 (14) MPEG /

(,)
 (, HTML, XML,)
 , GIF, JPEG, (HTML
 : Hypertext markup language)
 (GUI) HTML
 (Down)
 (Up)()
 가 /
 , DTV가 (source)
 (,) ; ()
 ; MPEG ;
 2 (100) 1394 (114)
 , (100) (14)(, DVD(108), DVCR(110)), (12)(,
 DTV(102,103), (116), DVCR(120), PC(105), / (107), DBS (109)
 ed) 3 (11) (Layer
 (150)() (152 164)
 (166) (150) (160)
 (166) (162 164)
 , 1394 (150, 166)
 , 7 (, (TCP/I
 P) (156) (154)). (, (160
) (152), (
 154), (156), (158), (162) (164)) (,
 (160)
 3 , VCR TV
). 가 가 GUI , GUI
 가 2 GUI 가 , GUI 2
 , 1394 (100) (164)
 (capability)(, (isochronous))
 / , 1394 (100) (,
 /). 가 1394 / , 1394
 , 1394 가 (가)
 (automatic configuration rest) , 1394 /
 가 , (100) 1394 ,)
 , ATM, (,) 1394
 2 , (100) 1394 (114) 가 DBSS(104)
 DBSS 1394 (122) , (NIU :
 Network interface unit) DBSS

108) (DVD:Digital video device)(108) (100) DVD(

(DVCR: Digital video cassette recorder)(110), TV(102)가 (100)

DTV(102) (100) 2 DTV(103) (100)

(100) DTV (102 103) DTV가 HTML (100)

(100) (PC)(105)

, PC(105)

1394 (114) HTTP/IP HTTP/TCP/IP

, IP (가 (One-way write only model)) , TCP IP

(, -' ') , HTTP 2- (, UDP/IP, F

TP/IP, TELNET/IP, SNMP/IP, DNS/IP, SMTP/IP) (Proxy)(1

16) , (100)

(116)(,) X10, (Lonworks), CEBus

4 HTML/HTTP/TCP/IP () 가 , 139

-IP (, AVC/FCP/1394)

, , 2 , HTTP/IP

1394 (114) (116) 가 (Neutral)(

X10) . HTML/HTTP/TCP/IP X10 , VCR- /AVC/FCP/139

4 HTML/HTTP/TCP/IP/1394 (16) , DVCR(120) (100

) 가 . ,

, 1394

, (Discovery)

가 (100) 1394 (Bridg

e box)

2 , DTV(102), DTV(103), PC(105), DVCR(110), DVD(108), DSS-NIU(104) DVCR(120

) (11) 1394 (100)

가 , DTV(102), DTV(103) PC(105)

DVCR(110), DVD(108), DSS0NIU(104) DVCR(120)

1394 (, MPEG

DVCR(100)), (UI) (,

DTV(102)) (, DTV(103)) (, MPEG) UI

가 . (WWW: World wide web) ()

(100) 1394WEB - - /

) , () , TM , TM ,) (, UI

GUI

< 4a >

(100) DTV(102) MPEG DVCR(

110) , DTV(102) DV

CR(110) DTV(102)

DTV(102) DVCR(110) (202) DTV(102)

(204) DTV(102)가

DTV(102) (200) DVCR(110) HTML GUI(202) DTV(102)

HTML GUI(204) (202, 204) HTML

(200) (202, 204)

(202, 204) (206, 212) (202, 204)

GUI(202 / 204) (100) 가

/ 가 DTV(102) (200)

DVCR(110) GUI(202) (Hyperlink) DVCR(110)

DVCR (208) DVCR(110) (206)(MPEG

/) , DVCR(110) MPEG (208)

DTV(102) (212) MPEG MP
 GE DTV(102) (210) . DVCR(102)
 (206) , (Acknowledgement),
 DTV(102) GUI(202) , DTV(102)
 (212) (206 212) ,
 1394 (Isochronous)
 4b (100) ,
 . DVCR(110) (100) DTV(102)
 MPEG , DTV(102)
 < > (100) (HTTP 1.1)
 , , . HTTP (100)
 . HTTP (Typing) (Negotia
 tion)
 <GUI >
 GUI (202, 204) (Description document language)
 , HTML, 4.0 . HTML
 (style sheet) . HTML 4.0 ISO 8879 SGML(Standard generali
 zed markup language)
 < >
 , HTML 1394WEB
 (100)
 (GIF89s: Graphic interchange format), 가 (JPEG: Progressive joint p
 hotographic experts group) (PNG: Portable network graphics) . 1

[1] -

	PNG	JPEG	GIF89a
	48	24	8
		16.7	256
	(RASTER),		
(SCHEME)	LZ77	JPEG	LZW
	amp; RGB		2 ()
	256		
가			
	100%		
	48		
	16		
-			
()			
가 -			
	, (Chunk)		

< >

GUI (202), ECMA-Script-262 (architecture) (200) / (200)

(200) EXMA- (Loading), ECMA- (Unloading), (Abort), (Submission), HTML (202 204) (200)

< > (200) HTTP1.1 GUI(202 / 204)가 (DTV(102)) (200) 1394WEB (Persistence) HTTP1.1 '8.1.2.1' , DTV(102) HTTP1.1 가 1394 DVCR(110) (HTTP RFC2068), HTTP1.1 가 (200)가 DVCR(110) GUI (202) DVCR(100) DVCR(110) GUI (200) DTV(102) HTML 4.0 (202, 204) GUI (200) : (1) 480x640 (480x64 0 GUI(202, 204) GUI(202, 204) 480x640 ; (2) : , GIF89a, JPEG, PNG; : , CS S1 CSS2; (4) 가 가 if)' (sefif)' (times new roman); ' - (sans-sef (helvetica); ' (cursive)' - (zapf-chancery); ' (fanta sy)' (western); ' (monospace)' (courier)가 (200) ; (5) ECMA-262 GUI (200) / TM TM < > (, 1394WEB , DVCR(110)) 가 : (1) HTTP1.1 (, DTV(102))가 HTTP1.1 '8.1.2.1' HTTP1.1 (DVCR(110))가 가 HTTP1.1 '8.1.2.1' 가 HTTP 1.1 . 1394WEB (100) (Full status reporting) DVCR(110) GUI(2 02) DTV(102) (200) , 가 HTTP (Conditional GET) 가 (200) 가 HTML , 가 (100) 가 가 , EIA-775.1 HTTP ' ' 가 (2) , HTML4.0 GUI (202,204) icon.htm, name.htm, logo.ht m, index.htm, gif index.htm icon.htm name.htm HTML HTML 'INDEX.HTML' 'INDEX.HTML' M' . INDEX.HTM ICON.HTM NAME.HTM 'INDEX.HT M' LOGO.HTM 가 , LOGO.GIF ICON.GIF M (202,204) (100) ,

GUI 480 x 640 GUI GUI(202) (20
 0) 480 x 640
 (3) (200) (220)(
 5 6)
 (, GIF, JPG PNG) ICON.HTM , ICON.HTM(D
 VCR) HTML (202) INDEX.HTM ICON.HTM(DTV) HTML (204) INDEX.H
 TM (, INDEX.HTM) ICON.HTM
 (200) (100) (220) (220)
 ((202) INDEX.HTM)가 (220)
 가 , , , (100)
 (220) : HTTP
 ICON.HTM (; GIF, JPG PNG ; 70(V) x 130
 (H) 가
 (4) (, GIF, JPG PNG) LOGO.HTM , LOGO.HTM(D
 VCR) HTML (202) INDEX.HTM LOGO.HTM(DTV) HTML (204) INDEX.H
 TM (, INDEX.HTM) LOGO.HTM (220)
 (220) ((220)
 202)가 가
 (100) : HTTP
 (220) LOGO.HTM; GIF, JPG PNG ; 70(V) x
 130(H)
 (5) (NAME) (202)
 HTML NAME.HTM (, DTV가 , TV' , TV'
 가 , DVCR DTV (220)
 / / : HTTP NAME.HTM; 10 가 ,
 NAME.HTM 가 / (70 x 130)
 20, 130 5 6 , - UI(220)
 htm) (icon.htm) (logo.htm) (name.
) (250) (9a 9c
 GUI 가 'info.html' 'info.htm'
 (6) HTML4.0 HTTP
 202 INFO.HTML 2

[2] -

	(가)
	가 (가)
	(VCR, DSS, TV)

URL	URL
	:
	:
	()
	()

2 , URL . 2 가 가

(Entry) 가 DTV DVCR 가

가 가 DTV 가 1394 1394 (Sin

k) () , 1394 (Sin

1394 1394

(Attribute) ()

/ 가 (100) 가

(About)

< 1394WEB > () (100)

(200) 5 6 (200)

(220)(GUI) (220) (

가 (Launch)) (220) (

4b (200) (204) HN- HTM(: (1) (102) (200)가 (2) (200)

(202,204) HTM icon.htm names.htm - UI (3) (200)

(200) (202,204) (, GIF) - UI (4) (5)

(200) HN_ (220) ((220) (100) DVCR(110)

'INDEX.HTM' (6) 가 DVCR(110)

GUI(220) DVCR , DVCR(110) 'INDEX.HTM' (

220) DVCR(110) (202) 'INDEX.HTM'(DVCR -

htm) DVCR (, (icon.

) DTV(102) (200) DVCR (110) 'INDEX.HTM'

DVCR(110)

'INDEX.HTM' ICON.HTM NAME.HTM 'INDEX.HTM'

, ICON.HTM LOGO.HTM (LOGO.GIF IC

ON.GIF) , LOGO.HTM 가 HN_

HTML (NAME) 가

5 6 (, DTV(102), HDTV(1)) - GUI (220)
 (, DVCR(110)) 가 ,
 GUI(220) (' , , (,
 가 GUI (, ISO/IEC
 13213 8 , 1394 ((ROM))
 가 가 ,
 , 1394 ,
 , , ,
 , , ,
 가 , IEEE1394
 ,
 <1394 >
 7 (300) ,가
 , 1394 (114) 2 (100) 7 (14)(
 , DVD(108), DVCR(110)) (12)(, DTV(102))
 (300) 1394 3 , , A
 TM (Throughput)
 14) 가 (300) 1394 (1
 DBSS(104) 가 DBSS 1394 (114)
 ('NIU') DBSS (DVD)(108)
 (300) DVD(108)
 V(DTV)(102) (100) , DTV(102) (DVCR)(110), T
 0) 가 (300) (30
 2 DTV(103) 가 (300) DTV (102 103)
 HTML (300)
 가
 (PC)(105)
 1394 (114) HTTP/IP HTTP/TCP/IP
 , IP (, TCP IP (,
), HTTP 2- (,
). (, TCP/IP, UDP/IP, FTP/IP, TELNET/IP, SNMP/IP, D
 NS/IP, SMTP/IP) (116) (300)
 , 7 , HTTP/IP 1394 (114)
 (116) (118)(, X10) . HTLM/HTTP/TCP/IP X10
 , DVCR(120) /ACV/FCP/1394 HTML/HTTP/CTP/IP/1394
 (300) 가
 (119)(,) (121) 1394
 (119) (117) 가
 (NAT : Network address translation) (117) (117) LAN
 IP
 , 'IPV4 (, ADSL)
 WWW -TV (119)
 (Private)(가 (117) (119) NAT
 , NAT (119) (IETF RFC 1918)
 (NAT (117)). PC

<IP / >
 (300) GUI/ (DNS, (Domain name service))
 GUI (300) GUI ()
 (200)(4a (300) 4b) GUI (200)(5 6)가
 (Look-up) ()
). DNS ()
 (1394 PC) DNS 가
 / DNS() PC
 'www.yahoo.com' IP , 216.32.74.52 ()
 HN GUI
 homewideweb.com(ip) 775 WEB UI DNS (Knowledge) 가
 DNS IP
 DNS (가 가 IP
 DNS). (가 가 IP
 가 , 1394 IP 가
 IP () IP 가
 IP : (1) DHCP DHCP
 (DHCP : Dynamic host configuration protocol), (2) DHCP
 (DHCP), (3) FWHCP(: Fire-wal
 I host configuration protocol) () FWHCP (2) IETF
 (DRAFT) 'draft-ietf-dhc-ipv4-autoconfig04.txt'
 DHCP BOOTP/UDP , 1394
 DHCP DHCP
 DHCP 가 (CE: Consumer e
 lectronics)
 1394 -ID'
 , 1394 (, IP)
 , IP (FWHCP) 1394
 가 FWHCP 1394WEB 1394 IP
 FWHCP DHCP (, IP),
 FWHCP 1394 1394 FWHCP 1394 1394
 WEB IP 1394가 FWHCP 1394 1394
 . 10.x.x.x IP 가
 , FWHCP IP
 DHCP/ - 1394가 DHCP
 IP , IP 24 RFC1918 (10.128.1
 .1 10.254.254.254) . 1394 IP
 (Heterogeneou
 s)
 1394 FWHCP DHCP 가
 IP IP , FWHCP
 , DHCP
 ARP 가 IP ,
 < >
 8 , IP 1394 ((300)) -1394 ((3
 , (119)) 가 , 1394 (3
 00) FWHCP -1394 (119) DHCP
 , 1394 (7 DTV DVCR) DHCP . 1394 -1394
 1394 DEVICE-3 1394 IP 1394 FWHCP
 . DEVICE-3 -1394
 -1394 IP 1394 (Leaf)
 , 1394 (300) (, - UI FWHCP)

IP -1394 1394 IP IP
 -1394 () ,1394 ' - ' -ID IP IP
 GUI IP IP
 DNS 1394WEB 1394 IP , 1394 IP (F
 WHCP) 1394 1394 IP , DHCP IP . FW
 HCP RFC1918 10.LH.X.X (1394가) 10.UH.X.X
 FWHCP ((Initiator)) (GUID : G
 .1394 (GUID : G
 loba unique identification) 가 . GUID
 1394WEB 가 FWHCP 가 .
 가- (Self-election) 가 GUID가
 -GUID가
 -1394 -1394 IP
 1394 - GUI (, 4a 4b, GUI(202,204)) -1394 IP
 .1394 가
 : (1) 1394 가_ID , (2) IP FWHCP, (3) UI
 1394 가-ID (/ /
) 1394 (, IP
 1394 가-ID) 1394 1394 , IP
 FWHCP(가- FWHCP) IP . , UP
 () IP 가 , UP
 (UI) 1394WEB IP .
 HTML -
 1394 (400) - UI (250) (9c)
 UI (250) 5 6 (220) -
 (200)
 1394 가-ID 가 1394 (300) UI
 (250) UI (-UI) , (DTV)
 (GUI(220) UI (250) GUI(220)
 GUI(220) UI (250) HTML HTML
 (300) HTML HTML
 (ICON.HTM .'
 (202 204) ; HTML 5 - ICON.HTM, LOGO.HT
 M NAME.HTM). HTML (250
) (Layer of abstraction) - (250
) HTML (202,204)(NAME.HTM (202,204)) ,
 가 GUI (220) , DTV DTV-B
 ED2 (220) 가
 DVCR , DVCR GUI(202)가 ('
). GUI(DVCR
) ' ,
 DVCR' NAME.HTM ' , DVCR
 (DVCR NAME.HTM NAME.HTM)
 GUI(220) 가 ' (Bad citizen)' - GU
 I(220) -
 < 9a 9c, 10, 11 , (400) 가 (400) :
 (1) 1394 (IEEE1212R); (2) 1394
 (1394DDA)(404); (3) IP (FWHCP)(406); (4) UI (408); (5)
 GUI (RUN-TIME) (410) (, 2 (200)). , 10 9a 9

c (400) DDA FWHCP (400) UIDGA

10 9a 9c

9a 10 , 1394 , 1394

A) (402) (500 502) (1394DD (404) (Inhibiting)) 1394DDA (404)

< 1394 >

(300) 1394 (402) 1394WEB IP (404 406) : (1) 64 GUID(1394 ID); (2) '10.1.1.1' '10.127.254.254' RFC 1918 IP (, 10.128.1.1 10.254.254.254) ; (3) '10.1.1.1' '10.127.254.254' GUI (4.254' IP (FWHCP (406)); (4) P IP ; (5) 1394 (1394DDA (404)); (6) 1394 (404) - - , IP 1394DDA IP 가 / (1394DDA IP). IP 가 (), FWHCP (406)가 HTTP ; (8) ' , ' , ' , ' ' HTML (202, 204) 1394 . <IEEE 1212 > 1394 (402) IEEE1212r, IEEE1212 IEC61883 (402) 가 . 3 - - (402) - - (Key) , EIA-775 가 DTV DVCR, STB, 가 , - - 가 - 3 IEC61883 가 1394WEB EIA-775 (IEC61883, EIA-775 1394WEB) (1394) [3] - ROM

오프셋(베이스 어드레스 FFFF F000 000)

버스_정보_블록

오프셋

04 00 ₁₆	04	crc_길이	rom_crc_값		
04 04 ₁₆	"1394"				
04 08 ₁₆	플래그들	예약	cyc_clk_acc	max_rec	예약
04 0C ₁₆	노드_벤더_id			chip_id_hi	
04 10 ₁₆	chip_id_lo				

여기서, 04 0C₁₆ 및 04 10₁₆은 64비트 GUID 혹은 전역 유일 ID로 또한 알려져 있다.

루트_디렉토리

오프셋

04 14 ₁₆	루트_길이	CRC
	03 ₁₆	모델_벤더_id
	81 ₁₆	벤더_네임_텍스츄얼_서술자 오프셋
	0C ₁₆	노드_능력
	8D ₁₆	노드_유일_id 오프셋
	D1 ₁₆	유니트_디렉토리 오프셋(IEC 61883)
	D1 ₁₆	유니트_디렉토리 오프셋(EIA-775)
	D1 ₁₆	유니트_디렉토리 오프셋(1394WEB)
	선택적	
XX XX ₁₆	C3 ₁₆	모델_디렉토리 오프셋

IEC_61883 4 (, 3). _SW_ , IEC61883 AV/C(0)

[4] - IEC_61883 (IEC_61883)

	CRC
12 16	_ _ID (1394TA = 00 A0 2D 16)
13 16	_SW_ (= 01 16)
....	<< 가 >>
....	...

EIA-775 5 . EIA-775 가 EIA-775

[5] - EIA-775

	CRC
12 16	_ _ID (EIA-775 = 005068 16)
13 16	_ _ (010100 16)

....	<< 가 >>
....	...

_ _ID
 =005068₁₆ EIA EIA-775
 EIA-775 6

[6] -	
1 (octet)	01 ₁₆
2	(01 ₁₆)
3	(00 ₁₆)

1394WEB 가 7 1394WEB 1394WEB
 [7] - 1394

	CRC
12 ₁₆	_ _ID (1394WEB = 00XXXX ₁₆)
13 ₁₆	_ _ (010100 ₁₆)
38 ₁₆	_ _
39 ₁₆	1394_ _ _ _
3A ₁₆	_IP_
3B ₁₆	_IP_
	IP_ _
-- ₁₆	<< 가 >>

_ _ID
 =00XXXX₁₆ 1394WEB 1394WEB
 1394WEB 8
 [8] -

1 (octet)	01 ₁₆
2	(01 ₁₆)
3	(00 ₁₆)

< _ _ (38₁₆) >
 (Architecture) IEEE1212R 8.8
 (38₁₆)
 [9] -

					FWHCP			IP ?
					()			
X					=1	1394	IP-	_1 _0
31		6	5	4	3	2	1	0(LSB)

1394 (402) IP (406) (408)

0 - IP (=) IP 가 (=) FWHCP(406) IP (404 40)

1,2 6) - () 1394DDA (404) 1394DDA (404) 1

394 (Clear) FWHCP (406) IP-FWHCP (406) 가

3 - FWHCP GUID FWHCP (406)가 FWHCP (406)

1394_ (39 16) - (300) 1394 (IMMEDIATE)

(404) 1394 가 가-ID IP UI (406 408) 1394

(403) _IP_ (3A 16) - 가

IP (3B 16) - IP IP

IP (BC 16) - 10 IP 1394

() IP (-1394) IP

[10] - IP_

-1 (n) 16	CRC-16 16
IP 1 (, 32)	
...	
IP n (, 32)	

(Control word)

(, 1394 , 1394)

9b UI IP (FWHCP)(406)(가 (406) 1

394 (300) 1394 (402) IP UI), FWHCP

(Commencement) (406) (IP UI)

9c), HTML - IP UI (250) UP (408)

(406) IP (406) IP (300) (406)

가 IP (406) 가, IP (406) 가 (406)

UI (UIDGA : UI Descrip

tion generation agent) IP (406)가(가)

(IP , 1394 (402) ID(GUID))

(, HN_ FWHCP가 3 (- -) UIDGA 가

. IP 가 , UI , UIDGA HN_ (410) (, 2 (

200)) UI HTML (250) , (Icon.HTm, Name.HTM Logo.HT
M (204 204)) HTTP
(Full) - GUI(220) HTML (250)
Icon.HTM, Name.HTM Logo.HTM
가 , ICON.GIF LOGO.GIF , GUI

<1394 (1394DDA)>
9a 9c , (300) 1394WEB (404)
(404) 1394 1394 1394
, 가 (Raw discovery) 1394 가_ID
/ 가_ID 1394 1394 1394
: (1) - 가,
, (2) - (Master) (, (Net topology) ((Contender) (

3) - (Link-on) 가 가 가 가
(404) 1394 (404) 1394 (406 408) , ((

2 1, : 1394DDA, IP) (500 502) : (1)
(404)가 1394 DDA (404) (1394DDA가
1394 (402) 1394 DDA가 IP IP (1394DDA가
IP (, ' 1394DDA' ' IP ') , 1394 DDA가
(, FWHCP가 (UI) UIDGA가 ; (2) 1394
(406,408) ; (3) 1394 (402) 1394 (402)
; (4) 1394 (402) ' 1394DDA' (402) FW
(()) IP 가 가 UIDGA
(408) (, -1394), IP IP (406) IP
FWHCP (406)가 FWHCP (406) IP 1
394 (300) -1394 (119) , 1394 (300) (406, 40
8) 가 IP 1394 (300) 1394
FWHCP (406)가 1394 (300)
(119) ,

<IP (FWHCP)>
9a 9c, 10 , IP (FWHCP)(406) , ' ' IP
1394 IP 1394 IP
1394WEB UI FWHCP (406) , FWHCP (406)
FWHCP (406) . 1394DDA(404) 1394
1394DDA (404) 139
4 DDA (404)가 FWHCP (406) 1394 DDA (404)가
IP ' IP (406) 1394 DDA (404)가
1394 DDA (, ' 1394 DDA') (Polli
ng) , FWHCP (406) 1394 DDA (404
) GUID (300) FWHCP (406) GUID (504), (404
가 (406) FWHCP (406) (506).
HCP GUID 가 FWHCP (406) (508). FW
(406) (510). FWHCP (406) (BIT 0) ((Array)' IP
(512). , ' () IP (가 - - OS
(514 518).

(D)
 1394WEB 가 . 7 _IP_ , _IP_
 FWHCP (406) IP (520 522). , FWHCP (, IP 524). 6 6)
 가 , 6 가 ,
 (- - : BIT 0) IP 가 , (528).
 (526). FWHCP (406) IP 가 ,
 <UI WWW , - 4b, 7, 9 11) , UI (, (100), (300),)
 - UI (, PC) (100) (UIDGA)(408) ,
 (220) UI (, DTV(102))가 UI (View)(220) UI
 UI 가' UI '() , UI , UI).
 (UI , 가 GUI UI)
 (100) 가 GUI (202, 204) ,
 -UI , GUI(220) GUI
 (410)((200)) , GUI (250) GUI
 UI (408) (, WWW RFC1918), 1394WEB UIDGA(408) (,)가 UIDGA
 UI IP (가 IP , UI () (100, 300) (220) : (1)
 1394 (200) (404), (2) UI (UIDGA)(408), (3) GUI (408) (,
 IP (410). 11 , UIDGA (408) 1394 (4 02) IP , FWHCP (406) (600). FWHCP (406)가 1394 (4 , 1394 DDA (404) , UIDGA (408) , HTML , HN_ (UIDGA (408) 5 6 - IP , (300) , IP (408) IP IP , HTML (, , , ,) IP , HTML (BIT 0) , 가 UIDGA(408) , 9, - - , UIDGA(408) 7 . , UIDGA (402) IP - IP- , GUI(220) (408) (IP_ - -) IP- , BC(IP_ - -) 1394WEB Icon.HTM (index.htm) 가 , IP_ UIDGA (408) IP (602) IP HTML(UI (250) (UIDGA HN_ , - UI , HTML) (604). UIDGA (408) icon.htm, name.htm log o.htm IP . UIDGA . UIDGA H

TML , , ICON.HTM, NAME.HTM, LOGO.HTM(, 2, 3, 4) HTML
 UIDGA (408) 가 icon.gif logo.gif - UI (250)
 가 , HTML
 (606).
 , UI - HTML UI (250) , G
 UI (220) , ICON.HTM LOGO.HTM
 NAME.HTM , HTML
 UI (250) , GUI(220)
 , 'name'
 GUI () , UI -
 GUI(220) UIDGA GUI
 (410)() (608).
 <GUI - >
 GUI (410)(, (200)) HTML UI (250) UI
 GUI (220) , (, DTV) 가
 (200) 'top-level-devices.html' (250)
 - GUI(220) , ()
 (-) GUI UIDGA 가 UI) (P
 . HN , - 가 . CE UI
 C) UIDGA (250) UIDGA (408) UIDGA (408)
 , (200) 가 UI (220)
 (, 'xxxxxx xxxxxxx http://ww
 w.service.com 'xxxxxx 가 xxx-xxx-xxxx
 GUI(220) , (200) HTML UI (250) UI) (202, 204)
 (, ICON.HTM HN_ HTML (202, 204) ()
 'icon.htm', 'name.htm', 'logo.htm' .
) 가 (AFTER USER CUSTOMIZATION)
 . 가 (200)
 'icon.htm', 'name.htm' 'logo.htm' (cache) 가 HTML
 (202, 204) 가 . HTTP '
 (200)
 HTML (202, 204) . H
 WW GUI 가
 (200) HN
 HTML(250) ,
 가
 가 HN (Refresh)
 (200) HN 가
 HTML(250) , 가 (100) 가 ,
 가 , EIA - 775.1
 HTTP '
 , (,)
 , (/ ,)
 / (Containers) ' ' /
 가 UI UI 가
 (UI) UI UI
 L , UI , HTML , HTML
 . HTML 가 icon.gif logo.gif 가 NAME HTML
 , - HTML - UI ,

UIDGA
GUI
GUI가
GUI
GUI가
)가 GUI
1394 UI가
UI (IP)가
WWW UI
(PC, DTV)가 (VIEW) GUI
(1) (250) (1); (2) B
ackground.htm (2); (3) Icon.htm (3); (4) Name.htm (4).
er interface) (UI: User Interface) (GUI: Graphical Us (11)
(Portal))
(702)(7) (250) (700) (300) (300) 1394 (11)(404)
, DTV(102) (11) UI (12)) (UIDGA)(408) (11) IP (DTV(103),
UI (TLNUID)(250)(11) IP (700) IP
(11) GUI(220) (11) (704) (702) UIDGA(408) UIDGA(408)가
P (704) UIDGA(408) (704) (704)
12 HTML HTML HTM (710a)(702) (704) (704)
HTML HTML (712a)(702) (704) (704)
UI(220)가 TLNUID(250) 13 TLNUID(250) G (710b, 712
b) (11) GUI (220)가 GUI(220) (11) GUI
(hit) (250) (11) (11)(DTV(102)) (11) UIDGA(408) - GU
I(220) GUI (UIDGA)(408) UIDGA(408)
(708b), (710b) (712b) (704) (704)
(710b) (700) (702) (704)
(220) (708b) (704)
(710b) (712b)

ogoname1.htm (710a) 12 (710a), 12 (710a), 12 (710a), 13 (712a) 12 (712b) 13 (712b) TLNUI(250) GUI(220) 가 .

ogoname1.htm logoname12.htm 가 , , .

(250) (710b) 13 HTML (710a) (710a, 712a) GUI(220) 12 가 (710b) (710b) (710b) GIF, JPG PNG() (710b) (710a) (250) logoname1.htm(710a) (710a) (710a) . logoicon1.htm (710a) (710a) . logoicon1.htm 가 2 (logoicon1_1.htm) (712a) (712B) (712b) (250) (logoicon.htm) () VCR 'VCR ')

logoname1.htm HTML 가 가 (11) (300) (704) (300) (404) IP (406) UIDGA(408) G UI(220) (TLNUI(250) (706b) (707b) , 12 UI (300) UI (GUI) (11) 13 (706a) (707a) UI (GUI) (250) 13 (710b) (712b) (712a) (702) 13 GUI(220) (710a) () (1394WEB UI (11)(, HDTV(102) (12)) 가 GUI HDTV(250) 가 12 13 GUI(220) HDTV(102) 가 GUI HDTV GUI HDTV GUI (702) (300)((702)) (704) TV) UIDGA(408)가 (, logoicon1.htm logoname1.htm) 12 13 TV 209.157.0.2 , (712b) (710b) (712b) , homewideweb.net, 209.157.0.2 (, logo icon2.htm logoname2.htm) TV TV GUI(220) (TM) (, logo (,) ISO/IEC 13213 8 , 1394 가 가 (11) -1394 (702)(, 7 14) (704) IP 1394 (11) 1394 (11) (700) (700) -1394 (702) ((, DTV(103)) (11)(, DTV(102)) ()) GUI(

220) (, (702) ()
704)) (710b) DTV UI (11)
() (710b) GUI(220) (11)
408) TV 1394 1394WEB IP ()
15 가) IP (800), IP 가
1394 (11) UIDGA(408) (802), UI (TLNUIID)(250)
(710a, 712a) UIDGA(408) DDA(4
04) (300) IP (804). UIDGA(40
8) IP (806) (702) HTML TLNUIID(250) (808). 12
, IP TLNUIID(250) (11)
TLNUIID - TLNUIID (250)
(11) , icon.htm(706a) (706b) , name.htm(707a)
(707b) (300)
(11) IP icon.htm name.htm
() (810).
(11) UIDGA(408) (700)가 (, DDA(404)
), 가 (, 2) ,
(708a) . TLNUIID(250) , UIDGA(408)
(710a) (710b)) , UIDGA(408) (708a)(
(702) IP ()
- (708a) (710a, 712a) (, logo
icon1.htm, logoname1.htm logoicon2.htm, logoname2.htm)(812).
() (710a, 712a) 가 /
) , logoicon1.htm(710a) logoname1.htm(712a) , TLNUIID(250
(410)
GUI(220) (814).
TLNUIID(250) , HTML /
(710b) (712b)
TLNUIID HTML(250) (710a)
(712b)) 가 icon.htm logoiconX.htm name.htm logonameX.htm
, HTML UI (250)
가 GUI(220) () 가 (250) UI
) - GUI () GUI
(, DTV(102) (12)) GUI
(11) (708b) 가 (11) GUI(220) (708b) -
GUI(220) GUI (11)
(708b) , / IP
(UIDGA)(408) IP 가 .
가 IP (702) IP 가 .
, UIDGA(408) (702) IP UIDGA(4
08)가 TLNUIID(250) , DDA(404) (300)
(11) (700) (702)
(702), (700) (702)() UIDGA(4

08) , GUI(220) T
 LNUID(250) IP , GUI(200)
 가 (702) / GUI(220) (710
 b) / (702) , (410) , (300) (7
 00) GUI(220) , UIDGA(408) ,
 , logoicon1.htm , GUI(220)
 yahoo.com, amazon.com IP ,
 IP () ,
 가 , 가 ,
 5 12 , 12 13 TLNUID GUI htm
 5 - - TLNUID(index.htm)
 6 - background.htm
 7 - icon.htm
 8 - name.htm
 9 - logoicon1.htm
 10 - logoname1.htm
 11 - logoicon2.htm
 12 - logoname2.htm
 - TLNUID(index.htm)(250) 12 13 TLNUID(250)
 GUI(220) (11) GUI(200) 75% IP
 . 25% , , TLNUID(250) (1
 1) (708b) . TLNUID(250) 10.X.X.X .
 (, 209.157.0.2) (710a, 712a) - IP
 TV (11) TLNUID (708b) ,
 'DVD 1' (11) (11) (408)
 (250) , (410)가 GUI(220) icon.htm(706a) TLNUID
 (721)) (11)
 ((720)) , , ,
 icon.htm(706a) (410)가 - GUI(220)
 (11) (410) (706a)
 on.htm(706a) icon.gif(706b) (11) ic
 index.htm가, 가
 name.htm(707a) GUI(220) (410)
 (11) . Name.htm(707a) (707b) (706b)
 ,
 logoicon1.htm(710a) (, homewideweb.com)
 (704) (710a) 가
 TNLUID(250) - (704)
 'homewideweb.com'
 - GUI(220) (11) logoicon1.htm(710a) (704)
 (704) logoname1.htm(712a) (710b)
 (11) (250) (704) logoicon1.htm (710a) 1
 - 가 , logoicon1.htm (710a) (710b) 2 - 가 .
 UIDGA(408) logoicon1.htm (710a) 1 -
 (250) (704) logoicon1.htm (710a)
 (410) logoicon1.htm (710a) 2 - (11
) GUI(220) (710b)(, (TM), (TM)
)

logoicon1.htm (710a) (704) (710b) (704) IP (704) logoicon2.htm (710a) (710b) (TM) IP 204.71.200.75 . DNS(logoicon2.htm (TM) IP 204.71.200.75 . DNS(logoicon2.htm GUI(220)가 / (300) 가 HTML (250) EIA-775 11 EIA-1394WEB EIA-1394WEB

[11] - EIA-1394

	CRC
12 ₁₆	_ _ID (EIA = 005068 ₁₆)
13 ₁₆	_ _ (010100 ₁₆)
38 ₁₆	_ _
39 ₁₆	1394_ _ _
3A ₁₆	_IP_
3B ₁₆	_IP_
BC ₁₆	IP_ _
BC ₁₆	IP_ _ _
-- ₁₆	<< 가 >>

_ _ID =005068₁₆ EIA EIA-1394WEB IP 1394 -1394 12 7). IP_ _ _ (BD₁₆) IP_ _ _ 10.X.X.X 가 255.0.0.0

[12] - IP_

-1 (n) ₁₆	CRC-16 ₁₆
IP 1 (32)	
...	
IP n (32)	

가 _ _ (, 13). (IEEE1212r) EIA-77 : _ID, _ID

[13] -

	CRC
17 16	_ID
81 16	- - -
...	<< 가 >>
...	...

(702) (704)

< >

(,) () - GUI

(,) GUI (UIDGA)

TV GUI

(RIC: Redirection Identification Code),

RIC (11) , IP 가 RIC

17 19 RIC

UIDGA RIC가 (820) (25)

0)(, 16) - UIDGA HTTP

(822). (410) (250) GUI(220)

(824). (908) RIC

(UI) (11) - (11) HTTP 가

6), (11) (908) (250) HTTP (82

(828). RIC/ (900) (908) RIC HTTP

(904) HTTP RIC (702) (910)

(830 832), (908) (910) (

11) (410) ()

(11) HTTP RIC

(908) (910)

18 20 (11) RIC (11)가 (908)

(908) (840). (908) RIC, RIC,

20 가 842 852 19 822 832 RIC

() HDTV(102) (11) 가

가 URL RIC 가 , HTTP / HDTV(102)

RIC

RIC HDTV(102)

HTTP (GET) (POST) R

IC (300) HDTV(102) (300)

(908) HDTV(102) RIC 가 , RIC HDTV

HDTV (910) (21). HDTV RIC

< >

UI (11) (RIC) RIC (5 9),
 RIC IP , IP ,
 UI 가
 (ISP: Internet Service Provider) IP IP ISP
 IP (, IP)
 가 , 9 가 , RIC 5 .5 가
 9 , IP 가
 < 가 >
 가
 HTTP 가 RIC (, (11))
 가 HTTP RIC URL
 UIDGA가 16 (250)(, RIC (250)) (41
 0)가 , logoname1.html(712A),) GUI(220) HTML (logoicon1.html(710A)) HT
 ML (710A 712A)) (11) (17 18 , , 가
 (11) GUI(220) (908) (11) RIC , RIC
 (908) (11) , RIC
) 1 , RIC ((908))
 (910) (910)(, ATT) URL , (11) (410) (91
 0) 가 (11) (908) . HTTP (11) , (910
 URL HTTP (RIC) (908) (11) (910
) URL , (410) (11) URL (910
 (910) 2 , (908) (910) HTML (906)(
 , , URL) HTML RIC HTML
 (906) , RIC (11) RIC 가 HTTP , HTML (9
 08) RIC HTML (906) (11) (908) , (910) HTML
 (906) (906) (11) (910) (410) URL .
 , 가 (410) (910) URL / ,
 (11) (910) URL (908) logoiconX logonameX , I
 SP,) (904) (RIC) (908) RIC (900) (910) ((11) HT
 , (908) RIC) RIC ((11) (11) HT
 TP , , RIC , , IP (900)
 , (900) (908)() IP / /HTML
 , (900) (900) ISP (910)
 RIC UIDGA(408) (25
 0) 가 (220) HTTP RIC , RIC HT
 TP (702) (908) . RIC , HTTP : (
 1) 1 , (908) (904)(, logoiconX I
 ogonameX) () RIC (908)
 (910) URL , (2) 2

nX (904) HTML (906) logoico
 (11)(HDTV(102)) HTTP (908) HTTP
 (11) RIC HTML (906) HTML (908) HTML (906)
 906) RIC (910) HTML (906) Att.com) (11) (410)
) (908) HTML (906) HTML (906) (11) (910) (910)
 , URL , 가 (410) (910) URL .
 / (11) (910) URL .
 (, URL) (, logoiconX logonameX) 가 , 5
 , 9 , IP RIC , .
 RIC (SERVLET)
 14 go.java(logoiconX logonameX) .
 URL http://ip address/servlet/go , ww
 w.att.com RIC http:// ip address/servlet/go?arecode=408
 URL 가 , RIC
 , URL RIC ,
 - (250) (702)(
 7) (704) (908)()
 , UI (11) , 12
 (250)(16) , RIC GUI(220)(12)
 - HTML , 12
 CGI / , / , ASP,
 , logoicon1 logoicon12, logoname1 logoname12) 가 , 1
 1 12 ()
 UI (17 18) - UIDGA
 가 RIC (250)(RIC UIDGA(408)
 - , 16) . RIC
 . - RIC
 UI (11) UIDGA , logoiconX(, logoicon1, logoicon2,) logonameX(
 , logoname1, logoname2,) (2
 50) - -
 RIC HTML . logoicon1.htm, logoname1.h
 tm, logoicon2.htm, logoname2.htm, (908)
 URL (904)(logoiconX logonameX) RIC .
 ((,)).
 , RIC (11) ,
 RIC (, yahoo.com amazon.com)
 , RIC 가 RIC
 < , 가 - >
 , RIC - (220) (702) (908) UIDGA HTTP
 , GUI logonameX가
 URL :
 http://209.157.0.2/cgi-bin/logoicon1?zip=95134,
 http://209.157.0.2/cgi-bin/logoicon1?zip=951342111,
 http://209.157.0.2/cgi-bin/logoicon1?ipaddress=165.35.2.1,
 http://209.157.0.2/cgi-bin/logoicon1?areaCode=408.
 , URL :
 http://209.157.0.2/cgi-bin/logoname1?zip=95134,
 http://209.157.0.2/cgi-bin/logoname1?zip=951342111,
 http://209.157.0.2/cgi-bin/logoname1?ipaddress=165.35.2.1,
 http://209.157.0.2/cgi-bin/logoname1?areaCode=408.

UIDGA UI (11) RIC(,
) HTTP (, 16 logoicon2?zip=95135) UI (11) RIC(,
 <RIC > 가 . 1 17 19
 RIC , RIC (902) . 2 18 20
 RIC (902) , 가 (908) . UI (11)(18 , HDTV)
 , UI (11)(, HDTV(102)) RIC가 (912) (908)
 (908) , ID (908) UIDGA(
 408) CIP (11) (902) RIC가
 P HDTV(102) IP , HDTV(102) , IP (902) I
 TV(102) RIC HDTV(102) , IP (702) RIC (908)
 HDTV(102) 가 RIC (902) IP (912) RIC (908)
 (902) , IP (910) IP (, 'n
 et' , RIC 가 가 가 IP 가 RIC , RIC
 가 UI (11)((912) 13) , (912) , RIC
 (TRAVERSE) , 가 , TCI ,
 / 가 TCI ,
) , (11) 가 (, , , ,
 (11) (, , , , ,
) (908) , (908) (908)
 (908) , (908) (904) (11) (908)
 15, 6, 7, 8, 16, 17, 18, 19 (908) (910)
 13 16 GUI HTM .
 < 22 , () (300) () (300) (12)(
 , 7, DTV(102), DVCR(120)) . / (300)
 , 3 VCR (HomeNetOnWeb)
 (1052), : (1050)(18 (908)),
 가 (300)
 , (1052)() ,) ,
 GUI, GUI(1054)()가 (1050)
 (1052) (300) PC, , PDA, (1052)
 (300) GUI(1054)(GUI) (300) (702)
) UIDGA(408)(, 9c) (1056)(,
 (1052) (300) (1050) /URL
 (408) , / IP /URL
 (702) (1052) GUI
 (1052)

(1045) -TV(1058)(, (220)
(300) TV, TV(1058))
(12) : 가 22 (1050), (1052), (300). 3
22 (1050)(, HN) : (300) (1052) (1050)
; (300)((702)) (1050) (1050)
; (1052) (300) HTTP (redirect) ;
1045) . 22 (300)가 (1050) (1050) ()
, P.C.) (300)((1050) 가) (1060) - (dial-up)
(300) , PC, , PDA, (1052)(
(300) GUI (1052)
1054) (202)(, 4a) (200) , HTML HN ()
HTML (200)(, 4a)
, HTTP 1.1, '8.1.2.1' , GUI가
1394WEB , H
TTP/1.1 GUI (250) GUI (200)
HTML4.0 HTML 4.0
- (GUI) = 480x640 , 480x640 가
- : GIF89a, JPEG, PNG.
- : CSS1 CSS2.
- : ()
: 'serif' Times New Roman, 'sans-serif' Helvetica, 'cursive'
Zapf-Chancery, 'fantasy' Western, 'monospace' Courier.
: ECMA-262.
: 가 . SSL(
(Secure Socket Layer)) 3.0 (1052) (10) (only)
54) (, - PC GUI(1054),) XSL HN
(, (702) GUI(1054) (300) (702)
GUI(HN (1062)(9c UIDGA(408))
(1050) (1064) (1064) (702)
(1052) (300) (1066) (1050) (1064)
(12)
(1052) (300) (1054) (1054) HTML (1052) (10)
50) (Java Servlet) HTML , / IP /U
RL (1066) (300) , 22 (702)
(1050) (1050) PC (1050)
(300) , , (300) 가

(300) (CA; Certification Authorities) (702) HN
 (1062) (300) : (1) (1050) , SSL (1050)
 , (2) (1050) (1050) ,
 23a 23d (300) (1050) ,
 , (300) IP , (HN) (1050)
 , (account) / (1050)
 HTTP HN (HTTPS) (1050) (702)(HTTPS HN(300) (30
) (,) (1052)(PC) (1050) HTTPS HTTPS (H
 0) (1050) (1052) www.homewideweb.com) (300)
 N)(300) (1050) (1052) (1050) HN (300)
 23a , (1054) (1050) HN
 IP (1062) (250)(12) , (702) HN /
) /URL (1054) (250) (250) (12) (105
 0) (250) (1062)(23a)
 가 (1064) (1064) (1052) (300)
 , HN (1062)((702) 가) (1052)
 (12) GUI
 C) (1056) (300) (, PC) (1050) P
 (1052) (900, 902). (1052)((1050)
 (1050) HTTPS (1052) (200)
 IP 가 ID/ 가 (1050) (1050) (1050) (1
 052) HTTP SSL (1050) HTTP (906). ()
 904). (1050) (1050) IP ((702)
 가 ID/) (908). (702) 가 (1050)
 (910). (702) (1054)(
)(20) (1050) (702) (1050) ()
 912). (1050) (702) (1054)
 HTTPS (914). (1052) (1054)
 () (916). (1054) (105
 2) (1052) (202) (300)
 (12) (1052) (920, 922). (1052) (1050)
 (1054) (1068) , (1050)
 (924). (1050) (250) () (928). IP (70
 (926), (702) () () /
 2) 가 (1050) () ()

TV(1058)) (702) (202) (300) (930). (702) (12)(9c DDA (404)) (1052) (1052) (1050) (1050) (932). (1050) (934). (936). HTTPS (938). 23c (1052) (1052) (300) (12) (202) (1052) (940, 942). (300) (12) (1052) (944). (1052) (946), (1050) (702) (1050) (948). (1050) (950). (702) (952). (702) (1050) (95) (VCR) (VCR) (VCR) (956). (300) (1050) (12) (958). (300) 23d (1052) (1052) (1060)(PC(1052) (1060)((1060)(ISP (300) (1056) (1050) (1052) (1060) (960). PC(1052) (962). (1060) (1060) (300) ISP (964) (966). ISP(ISP (1050) (1050) PC(1052) (1050) (968). (U2D) (D2D) (U2D, ; D2D, 가 가 HN (970). U2D (972). (12) , ISP (IP) .

(702) () (300) (12) () IP () IP ()
 (IP)가 GUI (1062)) () IP () IP ()
 , (1066) GUI (1062)) () IP () IP ()
 , 가 (22 24),
 :
 1. (1050) (1052) ;
 2. (1050) (1052) ;
 3. / (, SSL)
 4. (1050) (1050) ; (1050)
 (1050) (HN) ;
 5. (702) / ;
 6. (1050) 가 (1050) (1050) (300) ()
 , SSL), , (702)
 ;
 7. HN (1062) (1066) - (, -) IP ()
) HN HN (1054) ;
 8. HN (1054) HN (720) (1050)
 ;
 9. HN (1054) (1050) () (1064))
 10. (1052) , (1052) (1052) ; HTTP HTTP
 가 (1052) (1054) (1050) HTTP ()
 , HTTP (702) (1066), (1064) / IP
 11. HN () , (1062), (1066), (1064) / IP
 /URL ()
 12. 가 (12) (HN) ;
 (1052)
 24a / IP /URL 24a 23a , - IP 가
 . 24a PC) (1056) (300)
 (1052) , IP (1052) (900, 902).
 (1050) (300) 가 HTTPS ID/ 가
 HTTP SSL (1050) , HTTP (, PC)(1052)
 (1050) (1050) (906). (1050) 가
 ID/) IP ((300)
 () (908). (702) 가
 / (910). HN (1062) / IP /UR
 L HN HN () (911).)
 (702) (1050) (1054)(20)
 (702) (1054) , (912). (1050) (1052)
 (1054) () HTTPS (1052)
 () (914). (1052) (916).
 , HN (1062) - (-) ()
 IP () IP 가 IP (300)
 URL(URL) , HN
 : (1050) IP 가 , HN(300) IP 가 , (12)
 IP 가 .

(1054) (12) (1054) (1050) (1054) (1052) (202)가
 , / HN IP /URL / HN IP /URL
 가 GUI (1062)(, (702))
 , HN
 (/ IP /URL , GUI
 가 HN HTML , IP

```
<FRAMESET ROWS='73%, 27%' >
<FRAME SRC='http://10.1.1.63/icon.htm' SCROLLING='no' NORESIZE>
<FRAME SRC='http://10.1.1.63/name.htm' SCROLLING='no' NORESIZE>
</FRAMESET>
```

24b
) , - (-) IP /URL ()
 URL(URL)
 HN IP , (300) (12) URL((12)
 URL) 가 (300) (12) URL((1052)
 , HTTP (1020). (202)
 (220) (1054)
 URL() (, http://Private IP address/else)(1022),
 URL URL (12) HN(300) IP 가 (1024).
 URL :

https://HN Public Address/agent?Private IP address/else,
 (, https://207.188.120.88/agent?10.1.1.63/icon.htm);
 URL
 (220)
 (1050) IP 가 URL URL URL

https://Home Portal IP address/redirect?HN Public Address/redirect?Private IP address/else,
 (
 https://211.45.27.151?redirect?207.188.120.88/agent?10.1.1.63/icon.htm);
 URL(URL) (1052) URL URL
 (old) URL URL (1028). , URL
 (300) , (200) URL() (10
 52) (1054) URL
 가 , (202) URL ()
 URL () (202) (1052) (,
 (202) (1052) (,
)(1030).

24c
 , (1054) URL() (300)
 (, URL (1054)
)(1000). , SSL , HN (1054)
 http://가 https://
 , URL (1050) IP
 HN(300) IP ,

https://Home Portal IP address/redirect?HN Public Address/agent?Private IP address/else;
 , IP http://211.45.27.151 , IP http://207.188.120.8
 8 http://10.1.1.63/icon.htm :
 https://211.45.27.151?redirect?207.188.120.88/agent?10.1.1.63/icon.htm.
 : (1) (300)
 (, (12) / (702)), / (2) (1050)

가 (300) (1052) (1052) (300)

(1064) (1050) (1050) (702) U

RL) (1052) URL(, URL (300) (

24c , URL HTTP HTTPS (300) (

; , URL CGI).

(1050) (, URL) (1002).

(1064) (300) (1004)(

, https://Home Portal IP address/redirect?HN Public Address/redirect?Private IP address/else

https://HN Public Address/redirect?Private IP address/else

(, https://207.188.120.88/agent?10.1.1.63/icon.htm)).

HN (702) (1050) (1006). HN

(702) (, (1066)) /

(300) (12) IP (1008):

https://HN Public Address/agent?Private IP address/else

http://Private IP address/else .

/URL IP URL (300) , HN(300)

가 .

HN (702) (1050) (1052) (1010).

(1052) HTTP HTTPS HTML ,

27 : (1) HN(300) (1050) (1052) ,

(1054) (202) HN , URL(

URL) URL (URL URL , URL IP

가), (2) (1052) (1050) HN(300) , URL

(URL , URL).

(1053) (300) (12) (1012)

가

, VCR, , 1 DVD, HDTV PC

1 - -

```

<HTML>
<HEAD>
<TITLE>HN Devices Page</TITLE>
</HEAD>
<FRAMESET ROWS='2%, 47%,2%, 22.5%,2%,22.5%, 2%' border=0 color=black>
<NOFRAMES>Sorry does not support frames</NOFRAMES>
<FRAMESET ROWS='100%,0%'>
<FRAME SRC='background.htm' SCROLLING='no' NORESIZE>
</FRAMESET>
<FRAMESET COLS='1.2%,23.5%,1.2%,48.2%,1.2%,23.5%,1.2%'>
<FRAMESET ROWS='100%,0%'>
<FRAME SRC='background.htm' SCROLLING='no' NORESIZE>
</FRAMESET>
<FRAMESET ROWS='48%,4%,48%'>
<FRAMESET ROWS='73%, 27%'>
<FRAME SRC='http://10.1.1.1/icon.htm' SCROLLING='no' NORESIZE>
<FRAME SRC=' http://10.1.1.1/name.htm' SCROLLING='no' NORESIZE>
</FRAMESET>
<FRAMESET ROWS='100%,0%'>
<FRAME SRC='background.htm' SCROLLING='no' NORESIZE>
</FRAMESET>

```

```

<FRAMESET ROWS='73%, 27%' >
<FRAME SRC=' http://10.1.1.10/icon.htm' SCROLLING='no' NORESIZE>
<FRAME SRC=' http://10.1.1.10/name.htm' SCROLLING='no' NORESIZE>
</FRAMESET>
</FRAMESET>
<FRAMESET ROWS='100%,0%'>
<FRAME SRC='background.htm' SCROLLING='no' NORESIZE>
</FRAMESET>
<FRAMESET ROWS='73%, 27%' >
<FRAME SRC=' http://10.1.22.1/icon.htm' SCROLLING='no' NORESIZE>
<FRAME SRC=' http://10.1.22.1/name.htm' SCROLLING='no' NORESIZE>
</FRAMESET>
</FRAMESET>
<FRAMESET ROWS='100%,0%'>
<FRAME SRC='background.htm' SCROLLING='no' NORESIZE>
</FRAMESET>
<FRAMESET ROWS='48%,4%,48%'>
<FRAMESET ROWS='73%, 27%' >
<FRAME SRC=' http://10.1.229.1/icon.htm' SCROLLING='no' NORESIZE>
<FRAME SRC=' http://10.1.229.1/name.htm' SCROLLING='no' NORESIZE>
</FRAMESET>
</FRAMESET>
<FRAMESET ROWS='100%,0%'>
<FRAME SRC='background.htm' SCROLLING='no' NORESIZE>
</FRAMESET>
<FRAMESET ROWS='73%, 27%' >
<FRAME SRC=' http://10.30.30.1/icon.htm' SCROLLING='no' NORESIZE>
<FRAME SRC=' http://10.30.30.1/name.htm' SCROLLING='no' NORESIZE>
</FRAMESET>
</FRAMESET>
<FRAMESET ROWS='100%,0%'>
<FRAME SRC='background.htm' SCROLLING='no' NORESIZE>
</FRAMESET>
</FRAMESET>
<FRAMESET ROWS='100%,0%'>
<FRAME SRC='background.htm' SCROLLING='no' NORESIZE>
</FRAMESET>
</FRAMESET>
<FRAMESET COLS='1.2%,23.5%,1.2%,23.5%,1.2%,23.5%,1.2%,23.5%,1.2%'>
<FRAMESET ROWS='100%,0%'>
<FRAME SRC='background.htm' SCROLLING='no' NORESIZE>
</FRAMESET>
</FRAMESET>
<FRAMESET ROWS='73%, 27%' >
<FRAME SRC=' http://10.41.1.1/icon.htm' SCROLLING='no' NORESIZE>
<FRAME SRC=' http://10.41.1.1/name.htm' SCROLLING='no' NORESIZE>
</FRAMESET>
</FRAMESET>
<FRAMESET ROWS='100%,0%'>
<FRAME SRC='background.htm' SCROLLING='no' NORESIZE>
</FRAMESET>
<FRAMESET ROWS='73%, 27%' >
<FRAME SRC=' http://10.41.21.1/icon.htm' SCROLLING='no' NORESIZE>
<FRAME SRC=' http://10.41.21.1/name.htm' SCROLLING='no' NORESIZE>
</FRAMESET>
</FRAMESET>
<FRAMESET ROWS='100%,0%'>
<FRAME SRC='background.htm' SCROLLING='no' NORESIZE>
</FRAMESET>
<FRAMESET ROWS='73%, 27%' >
<FRAME SRC=' http://10.45.1.1/icon.htm' SCROLLING='no' NORESIZE>
<FRAME SRC=' http://10.45.1.1/name.htm' SCROLLING='no' NORESIZE>
</FRAMESET>
</FRAMESET>
<FRAMESET ROWS='100%,0%'>
<FRAME SRC='background.htm' SCROLLING='no' NORESIZE>

```

```

</FRAMESET>
<FRAMESET ROWS='73%, 27%' >
<FRAME SRC=' http://10.100.1.1/icon.htm' SCROLLING='no' NORESIZE>
<FRAME SRC=' http://10.100.1.1/name.htm' SCROLLING='no' NORESIZE>
</FRAMESET>
<FRAMESET ROWS='100%,0%'>
<FRAME SRC='background.htm' SCROLLING='no' NORESIZE>
</FRAMESET>
</FRAMESET>
<FRAMESET ROWS='100%,0%'>
<FRAME SRC='background.htm' SCROLLING='no' NORESIZE>
</FRAMESET>
<FRAMESET COLS='1.2%,23.5%,1.2%,23.5%,1.2%,23.5%,1.2%,23.5%,1.2%'>
<FRAMESET ROWS='100%,0%'>
<FRAME SRC='background.htm' SCROLLING='no' NORESIZE>
</FRAMESET>
<FRAMESET ROWS='73%, 27%' >
<FRAME SRC=' http://10.122.22.1/eia.htm' SCROLLING='no' NORESIZE>
<FRAME SRC=' http://10.122.22.1/eia.htm' SCROLLING='no' NORESIZE>
</FRAMESET>
<FRAMESET ROWS='100%,0%'>
<FRAME SRC='background.htm' SCROLLING='no' NORESIZE>
</FRAMESET>
<FRAMESET ROWS='73%, 27%' >
<FRAME SRC=' http://10.122.122.122/icon.htm' SCROLLING='no' NORESIZE>
<FRAME SRC=' http://10.122.122.122/name.htm' SCROLLING='no' NORESIZE>
</FRAMESET>
<FRAMESET ROWS='100%,0%'>
<FRAME SRC='background.htm' SCROLLING='no' NORESIZE>
</FRAMESET>
<FRAMESET ROWS='73%, 27%' >
<FRAME SRC=' http://10.122.122.123/icon.htm' SCROLLING='no' NORESIZE>
<FRAME SRC=' http://10.122.122.123/name.htm' SCROLLING='no' NORESIZE>
</FRAMESET>
<FRAMESET ROWS='100%,0%'>
<FRAME SRC='background.htm' SCROLLING='no' NORESIZE>
</FRAMESET>
<FRAMESET ROWS='73%, 27%' >
<FRAME SRC=' http://10.122.122.124/icon.htm' SCROLLING='no' NORESIZE>
<FRAME SRC=' http://10.122.122.124/name.htm' SCROLLING='no' NORESIZE>
</FRAMESET>
<FRAMESET ROWS='100%,0%'>
<FRAME SRC='background.htm' SCROLLING='no' NORESIZE>
</FRAMESET>
</FRAMESET>
<FRAMESET ROWS='100%,0%'>
<FRAME SRC='background.htm' SCROLLING='no' NORESIZE>
</FRAMESET>
</FRAMESET>
<BODY BGCOLOR='#FFFFFF' TEXT='#000070' LINK='#0000ff' ALINK='#FF0000' VLINK='#007986'>
</BODY>
</HTML>

```

2 - Background.htm

```

<HTML>
<HEAD>
<TITLE>Background</TITLE>
</HEAD><BODY BGCOLOR='#007986'></BODY>
</HTML>

```

3 - Icon.htm

```

<HTML>
<HEAD>
<TITLE>Device Icon</TITLE>
</HEAD>
<BODY BGCOLOR='#FFFFFF0' TEXT='#000070' LINK='#0000ff' ALINK='#FF0000' VLINK='#007986'>
<br><br><CENTER>
<IMG SRC='icon.gif' border=0>
</CENTER>
</BODY>
</HTML>

```

4 - Name.htm

```

<HTML>
<HEAD>
<TITLE>Device Name</TITLE>
</HEAD>
<BODY BGCOLOR='#FFFFFF0' TEXT='#000070' LINK='#0000ff' ALINK='#FF0000' VLINK='#007986'>
<CENTER><FONT size=+0>Samsung Device</font></CENTER>
</BODY>
</HTML>

```

5 - - TLNUID (index.htm)

```

<HTML>
<HEAD>
<TITLE>HN Devices Page</TITLE>
</HEAD>
<FRAMESET ROWS='2%, 47%,2%, 22.5%,2%,22.5%, 2%' BORDER=0 COLOR=black>
<NOFRAMES>Sorry does not support frames</NOFRAMES>
<FRAMESET ROWS='100%,0%'>
<FRAME SRC='background.htm' SCROLLING='no' NORESIZE>
</FRAMESET>
<FRAMESET COLS='1.2%,23.5%,1.2%,48.2%,1.2%,23.5%,1.2%'>
<FRAMESET ROWS='100%,0%'>
<FRAME SRC='background.htm' SCROLLING='no' NORESIZE>
</FRAMESET>
<FRAMESET ROWS='48%,4%,48%'>
<FRAMESET ROWS='73%, 27%'>
<FRAME SRC='http://10.1.1.2/icon.htm' SCROLLING='no' NORESIZE>
<FRAME SRC='http://10.1.1.2/name.htm' SCROLLING='no' NORESIZE>
</FRAMESET>
<FRAMESET ROWS='100%,0%'>
<FRAME SRC='background.htm' SCROLLING='no' NORESIZE>
</FRAMESET>
<FRAMESET ROWS='73%, 27%' >
<FRAME SRC='http://10.1.1.63/icon.htm' SCROLLING='no' NORESIZE>
<FRAME SRC='http://10.1.1.63/name.htm' SCROLLING='no' NORESIZE>
</FRAMESET>
</FRAMESET>
<FRAMESET ROWS='100%,0%'>
<FRAME SRC='background.htm' SCROLLING='no' NORESIZE>
</FRAMESET>
<FRAMESET ROWS='73%, 27%' >
<FRAME SRC='icon.htm' SCROLLING='no' NORESIZE>
<FRAME SRC='name.htm' SCROLLING='no' NORESIZE>
</FRAMESET>
<FRAMESET ROWS='100%,0%'>
<FRAME SRC='background.htm' SCROLLING='no' NORESIZE>
</FRAMESET>
<FRAMESET ROWS='48%,4%,48%'>
<FRAMESET ROWS='73%, 27%' >
<FRAME SRC='http://10.41.1.2/icon.htm' SCROLLING='no' NORESIZE>

```

```

<FRAME SRC='http://10.41.1.2/name.htm' SCROLLING='no' NORESIZE>
</FRAMESET>
<FRAMESET ROWS='100%,0%'>
<FRAME SRC='background.htm' SCROLLING='no' NORESIZE>
</FRAMESET>
<FRAMESET ROWS='73%, 27%' >
<FRAME SRC='http://10.10.1.2/icon.htm' SCROLLING='no' NORESIZE>
<FRAME SRC='http://10.10.1.2/name.htm' SCROLLING='no' NORESIZE>
</FRAMESET>
</FRAMESET>
<FRAMESET ROWS='100%,0%'>
<FRAME SRC='background.htm' SCROLLING='no' NORESIZE>
</FRAMESET>
</FRAMESET>
<FRAMESET ROWS='100%,0%'>
<FRAME SRC='background.htm' SCROLLING='no' NORESIZE>
</FRAMESET>
<FRAMESET COLS='1.2%,23.5%,1.2%,23.5%,1.2%,23.5%,1.2%,23.5%,1.2%'>
<FRAMESET ROWS='100%,0%'>
<FRAME SRC='background.htm' SCROLLING='no' NORESIZE>
</FRAMESET>
<FRAMESET ROWS='73%, 27%' >
<FRAME SRC='http://10.1.1.200/icon.htm' SCROLLING='no' NORESIZE>
<FRAME SRC='http://10.1.1.200/name.htm' SCROLLING='no' NORESIZE>
</FRAMESET>
<FRAMESET ROWS='100%,0%'>
<FRAME SRC='background.htm' SCROLLING='no' NORESIZE>
</FRAMESET>
<FRAMESET ROWS='73%, 27%' >
<FRAME SRC='http://10.1.10.20/icon.htm' SCROLLING='no' NORESIZE>
<FRAME SRC='http://10.1.10.20/name.htm' SCROLLING='no' NORESIZE>
</FRAMESET>
<FRAMESET ROWS='100%,0%'>
<FRAME SRC='background.htm' SCROLLING='no' NORESIZE>
</FRAMESET>
<FRAMESET ROWS='73%, 27%' >
<FRAME SRC='http://10.1.99.2/icon.htm' SCROLLING='no' NORESIZE>
<FRAME SRC='http://10.1.99.2/name.htm' SCROLLING='no' NORESIZE>
</FRAMESET>
<FRAMESET ROWS='100%,0%'>
<FRAME SRC='background.htm' SCROLLING='no' NORESIZE>
</FRAMESET>
<FRAMESET ROWS='73%, 27%' >
<FRAME SRC='http://10.1.99.9/icon.htm' SCROLLING='no' NORESIZE>
<FRAME SRC='http://10.1.99.9/name.htm' SCROLLING='no' NORESIZE>
</FRAMESET>
<FRAMESET ROWS='100%,0%'>
<FRAME SRC='background.htm' SCROLLING='no' NORESIZE>
</FRAMESET>
</FRAMESET>
<FRAMESET ROWS='100%,0%'>
<FRAME SRC='background.htm' SCROLLING='no' NORESIZE>
</FRAMESET>
<FRAMESET COLS='1.2%,23.5%,1.2%,23.5%,1.2%,23.5%,1.2%,23.5%,1.2%'>
<FRAMESET ROWS='100%,0%'>
<FRAME SRC='background.htm' SCROLLING='no' NORESIZE>
</FRAMESET>
<FRAMESET ROWS='73%, 27%' >
<FRAME SRC='http://209.157.0.2/logoicon1.htm' SCROLLING='no' NORESIZE>

```



```

<FRAME SRC='http://209.157.0.2/logoname1.htm' SCROLLING='no' NORESIZE>
</FRAMESET>
<FRAMESET ROWS='100%,0%'>
<FRAME SRC='background.htm' SCROLLING='no' NORESIZE>
</FRAMESET>
<FRAMESET ROWS='73%, 27%' >
<FRAME SRC='http://209.157.0.2/logoicon2.htm' SCROLLING='no' NORESIZE>
<FRAME SRC='http://209.157.0.2/logoname2.htm' SCROLLING='no' NORESIZE>
</FRAMESET>
<FRAMESET ROWS='100%,0%'>
<FRAME SRC='background.htm' SCROLLING='no' NORESIZE>
</FRAMESET>
<FRAMESET ROWS='73%, 27%' >
<FRAME SRC='http://209.157.0.2/logoicon3.htm' SCROLLING='no' NORESIZE>
<FRAME SRC='http://209.157.0.2/logoname3.htm' SCROLLING='no' NORESIZE>
</FRAMESET>
<FRAMESET ROWS='100%,0%'>
<FRAME SRC='background.htm' SCROLLING='no' NORESIZE>
</FRAMESET>
<FRAMESET ROWS='73%, 27%' >
<FRAME SRC='http://209.157.0.2/logoicon4.htm' SCROLLING='no' NORESIZE>
<FRAME SRC='http://209.157.0.2/logoname4.htm' SCROLLING='no' NORESIZE>
</FRAMESET>
<FRAMESET ROWS='100%,0%'>
<FRAME SRC='background.htm' SCROLLING='no' NORESIZE>
</FRAMESET>
</FRAMESET>
<FRAMESET ROWS='100%,0%'>
<FRAME SRC='background.htm' SCROLLING='no' NORESIZE>
</FRAMESET>
</FRAMESET>
<BODY BGCOLOR='#FFFFFF0' TEXT='#000070' LINK='#0000ff' ALINK='#FF0000' VLINK='#007986'>
</BODY>
</HTML>

```

6 - background.htm

```

<HTML>
<HEAD>
<TITLE>Background</TITLE>
</HEAD>
<BODY BGCOLOR='#007986'></BODY>
</HTML>

```

7 - icon.htm

```

<HTML>
<HEAD>
<TITLE>Device Icon</TITLE>
</HEAD>
<BODY BGCOLOR='#FFFFFF0' TEXT='#000070' LINK='#0000ff' ALINK='#FF0000' VLINK='#007986'>
<BR><BR>
<CENTER>
<A HREF='index.htm' TARGET='_blank'><IMG SRC='icon.gif' BORDER=0></A>
</CENTER>
</BODY>
</HTML>

```

8 - name.htm

```

<HTML>
<HEAD>
<TITLE>Device Name</TITLE>
</HEAD>
<BODY BGCOLOR='#FFFFFF0' TEXT='#000070' LINK='#0000ff' ALINK='#FF0000' VLINK='#007986'>

```

```
<CENTER>
<FONT SIZE=+0>HDTV Master Bedroom</FONT></CENTER>
</BODY>
</HTML>
```

9 - logoicon1.htm

```
<HTML>
<HEAD>
<TITLE>Logo Icon 1</TITLE>
</HEAD>
<BODY BGCOLOR='#FFFFFF' TEXT='#000070' LINK='#0000ff' ALINK='#FF0000' VLINK='#007986'>
<CENTER>
<A HREF='http://209.157.0.2' TARGET='_blank'><IMG SRC='hww1.gif' BORDER=0></A>
</CENTER>
</BODY>
</HTML>
```

10 - logoname1.htm

```
<HTML>
<HEAD>
<TITLE>Logo Name 1</TITLE>
</HEAD>
<BODY BGCOLOR='#FFFFFF' TEXT='#000070' LINK='#0000ff' ALINK='#FF0000' VLINK='#007986'>
<CENTER>
<A HREF='http://209.157.0.2' target='_blank'>Home Wide Web</A>
</CENTER>
</BODY>
</HTML>
```

11 - logoicon2.htm

```
<HTML>
<HEAD>
<TITLE>Logo Icon 2</TITLE>
</HEAD>
<BODY BGCOLOR='#FFFFFF' TEXT='#000070' LINK='#0000ff' ALINK='#FF0000' VLINK='#007986'>
<BR><BR>
<CENTER>
<A HREF='http://204.71.200.75' TARGET='_blank'><IMG SRC='yahoo.gif' BORDER=0></A>
</CENTER>
</BODY>
</HTML>
```

12 - logoname2.htm

```
<HTML>
<HEAD>
<TITLE>Logo Name 2</TITLE>
</HEAD>
<BODY BGCOLOR='#FFFFFF' TEXT='#000070' LINK='#0000ff' ALINK='#FF0000' VLINK='#007986'>
<CENTER>
<A HREF='http://204.71.200.75' TARGET='_blank'>Directory Services</A>
</CENTER>
</BODY>
</HTML>
```

13 -

An Perl trace route example program for regional service using service provider IP address as RIC.

```
#!/usr/bin/perl
# full path to 'traceroute' executable
$traceroute = '/usr/sbin/traceroute';
# path to the script
$url = '/cgi-bin/traceroute.cgi';
# your title
$title = 'Traceroute Script';
```

```

if ($ENV{'CONTENT_LENGTH'} ne '') {
read(STDIN, $buffer, $ENV{'CONTENT_LENGTH'});
@pairs = split(/&/, $buffer);
foreach $pair (@pairs)
{
($name, $value) = split(/=/, $pair);
$value =~ tr/+ / /;
$value =~ s/%([a-fA-F0-9][a-fA-F0-9])/pack('C', hex($1))/eg;
$value =~ s/~! / ~!/g;
$FORM{$name} = $value;
}
}
$FORM{'host'} =~ s/( \ ;)//g;
print 'Content-type:text/html \n \n';
print '<HTML> \n <HEAD><TITLE>$title</TITLE></HEAD><BODY BGCOLOR= \ '#FFFFFF \ ' LINK= \ '#FF
FFFF \ ' VLINK= \ '#FFFFFF \ ' ALINK= \ '#FFFFFF \ '> ';
if ($FORM{'host'} eq ''){
print <<EOFHTML;
<FORM METHOD='POST' ACTION='$url'>
<TABLE WIDTH='350' CELLPADDING='0' CELLSPACING='0' BORDER='0'>
<TR ALIGN='CENTER'><TD BGCOLOR='#ffbc2a'>&nbsp;&nbsp;<BR><INPUT TYPE='TEXT' SIZE='18' MAXSIZE
='40' NAME='host' VALUE='domain.com'><BR>&nbsp;&nbsp;</TD><TD BGCOLOR='#000000'>&nbsp;&nbsp;<BR><I
NPUT TYPE='SUBMIT' VALUE='CHECK'><BR>&nbsp;&nbsp;</TD></TR>
<TR><TD ALIGN='CENTER' COLSPAN='2' BGCOLOR='#CCCCCC'><FONT COLOR='#FFFFFF' SIZE='-2'>All
rights reserved. <A HREF='http://www.fastgraf.com'>Fastgraf</A> (c) 1998</FONT></TD></TR>
</TABLE>
EOFHTML
}
else
{
$txt = `$traceroute $FORM{'host'}`;
print <<EOFHTML;
<TABLE WIDTH='100%' HEIGHT='40'>
<TR><TD BGCOLOR='#ffbc2a'><B>$title</B></TD></TR>
</TABLE>
<PRE>$txt</PRE>
EOFHTML
}
print '</BODY></HTML>';
exit 0;
14 -
package redirect;
import javax.servlet.*;
import javax.servlet.http.*;
import java.io.*;
import java.util.*;
public class go extends HttpServlet {
//Initialize global variables
public void init(ServletConfig config) throws ServletException {
super.init(config);
}
//Process the HTTP Get request
public void doGet(HttpServletRequest request, HttpServletResponse response) throws ServletException, IO
Exception {
response.setStatus(response.SC_MOVED_TEMPORARILY);
response.setHeader('Location', 'http://www.att.com');
}
//Process the HTTP Post request

```

```

public void doPost(HttpServletRequest request, HttpServletResponse response) throws ServletException, IOException {
    response.setStatus(response.SC_MOVED_TEMPORARILY);
    response.setHeader('Location', 'http://www.att.com');
}
//Get Servlet information
public String getServletInfo() {
    return 'redirect.go Information';
}
}

```

15 - - TLNUID (index.htm)

```

<HTML>
<HEAD>
<TITLE>HN Devices Page</TITLE>
</HEAD>
<FRAMESET ROWS='2%, 47%,2%, 22.5%,2%,22.5%, 2%' BORDER=0 COLOR=black>
<NOFRAMES>Sorry does not support frames</NOFRAMES>
<FRAMESET ROWS='100%,0%'>
<FRAME SRC='background.htm' SCROLLING='no' NORESIZE>
</FRAMESET>
<FRAMESET COLS='1.2%,23.5%,1.2%,48.2%,1.2%,23.5%,1.2%'>
<FRAMESET ROWS='100%,0%'>
<FRAME SRC='background.htm' SCROLLING='no' NORESIZE>
</FRAMESET>
<FRAMESET ROWS='48%,4%,48%'>
<FRAMESET ROWS='73%, 27%'>
<FRAME SRC='http://10.1.1.2/icon.htm' SCROLLING='no' NORESIZE>
<FRAME SRC='http://10.1.1.2/name.htm' SCROLLING='no' NORESIZE>
</FRAMESET>
<FRAMESET ROWS='100%,0%'>
<FRAME SRC='background.htm' SCROLLING='no' NORESIZE>
</FRAMESET>
<FRAMESET ROWS='73%, 27%' >
<FRAME SRC='http://10.1.1.63/icon.htm' SCROLLING='no' NORESIZE>
<FRAME SRC='http://10.1.1.63/name.htm' SCROLLING='no' NORESIZE>
</FRAMESET>
</FRAMESET>
<FRAMESET ROWS='100%,0%'>
<FRAME SRC='background.htm' SCROLLING='no' NORESIZE>
</FRAMESET>
<FRAMESET ROWS='73%, 27%' >
<FRAME SRC='icon.htm' SCROLLING='no' NORESIZE>
<FRAME SRC='name.htm' SCROLLING='no' NORESIZE>
</FRAMESET>
<FRAMESET ROWS='100%,0%'>
<FRAME SRC='background.htm' SCROLLING='no' NORESIZE>
</FRAMESET>
<FRAMESET ROWS='48%,4%,48%'>
<FRAMESET ROWS='73%, 27%' >
<FRAME SRC='http://10.41.1.2/icon.htm' SCROLLING='no' NORESIZE>
<FRAME SRC='http://10.41.1.2/name.htm' SCROLLING='no' NORESIZE>
</FRAMESET>
<FRAMESET ROWS='100%,0%'>
<FRAME SRC='background.htm' SCROLLING='no' NORESIZE>
</FRAMESET>
<FRAMESET ROWS='73%, 27%' >
<FRAME SRC='http://10.10.1.2/icon.htm' SCROLLING='no' NORESIZE>
<FRAME SRC='http://10.10.1.2/name.htm' SCROLLING='no' NORESIZE>
</FRAMESET>

```

```

</FRAMESET>
<FRAMESET ROWS='100%,0%'>
<FRAME SRC='background.htm' SCROLLING='no' NORESIZE>
</FRAMESET>
</FRAMESET>
<FRAMESET ROWS='100%,0%'>
<FRAME SRC='background.htm' SCROLLING='no' NORESIZE>
</FRAMESET>
<FRAMESET COLS='1.2%,23.5%,1.2%,23.5%,1.2%,23.5%,1.2%,23.5%,1.2%'>
<FRAMESET ROWS='100%,0%'>
<FRAME SRC='background.htm' SCROLLING='no' NORESIZE>
</FRAMESET>
<FRAMESET ROWS='73%, 27%' >
<FRAME SRC='http://10.1.1.200/icon.htm' SCROLLING='no' NORESIZE>
<FRAME SRC='http://10.1.1.200/name.htm' SCROLLING='no' NORESIZE>
</FRAMESET>
<FRAMESET ROWS='100%,0%'>
<FRAME SRC='background.htm' SCROLLING='no' NORESIZE>
</FRAMESET>
<FRAMESET ROWS='73%, 27%' >
<FRAME SRC='http://10.1.10.20/icon.htm' SCROLLING='no' NORESIZE>
<FRAME SRC='http://10.1.10.20/name.htm' SCROLLING='no' NORESIZE>
</FRAMESET>
<FRAMESET ROWS='100%,0%'>
<FRAME SRC='background.htm' SCROLLING='no' NORESIZE>
</FRAMESET>
<FRAMESET ROWS='73%, 27%' >
<FRAME SRC='http://10.1.99.2/icon.htm' SCROLLING='no' NORESIZE>
<FRAME SRC='http://10.1.99.2/name.htm' SCROLLING='no' NORESIZE>
</FRAMESET>
<FRAMESET ROWS='100%,0%'>
<FRAME SRC='background.htm' SCROLLING='no' NORESIZE>
</FRAMESET>
<FRAMESET ROWS='73%, 27%' >
<FRAME SRC='http://10.1.99.9/icon.htm' SCROLLING='no' NORESIZE>
<FRAME SRC='http://10.1.99.9/name.htm' SCROLLING='no' NORESIZE>
</FRAMESET>
<FRAMESET ROWS='100%,0%'>
<FRAME SRC='background.htm' SCROLLING='no' NORESIZE>
</FRAMESET>
</FRAMESET>
<FRAMESET ROWS='100%,0%'>
<FRAME SRC='background.htm' SCROLLING='no' NORESIZE>
</FRAMESET>
<FRAMESET COLS='1.2%,23.5%,1.2%,23.5%,1.2%,23.5%,1.2%,23.5%,1.2%'>
<FRAMESET ROWS='100%,0%'>
<FRAME SRC='background.htm' SCROLLING='no' NORESIZE>
</FRAMESET>
<FRAMESET ROWS='73%, 27%' >
<FRAME SRC='http://209.157.0.2/logoicon1?zip=95134' SCROLLING='no' NORESIZE>
<FRAME SRC='http://209.157.0.2/logoname1?zip=95134' SCROLLING='no' NORESIZE>
</FRAMESET>
<FRAMESET ROWS='100%,0%'>
<FRAME SRC='background.htm' SCROLLING='no' NORESIZE>
</FRAMESET>
<FRAMESET ROWS='73%, 27%' >
<FRAME SRC='http://209.157.0.2/logoicon2?zip=95134' SCROLLING='no' NORESIZE>
<FRAME SRC='http://209.157.0.2/logoname2?zip=95134' SCROLLING='no' NORESIZE>
</FRAMESET>

```

```

<FRAMESET ROWS='100%,0%'>
<FRAME SRC='background.htm' SCROLLING='no' NORESIZE>
</FRAMESET>
<FRAMESET ROWS='73%, 27%' >
<FRAME SRC='http://209.157.0.2/logoicon3?zip=95134' SCROLLING='no' NORESIZE>
<FRAME SRC='http://209.157.0.2/logoname3?zip=95134' SCROLLING='no' NORESIZE>
</FRAMESET>
<FRAMESET ROWS='100%,0%'>
<FRAME SRC='background.htm' SCROLLING='no' NORESIZE>
</FRAMESET>
<FRAMESET ROWS='73%, 27%' >
<FRAME SRC='http://209.157.0.2/logoicon4?zip=95134' SCROLLING='no' NORESIZE>
<FRAME SRC='http://209.157.0.2/logoname4?zip=95134' SCROLLING='no' NORESIZE>
</FRAMESET>
<FRAMESET ROWS='100%,0%'>
<FRAME SRC='background.htm' SCROLLING='no' NORESIZE>
</FRAMESET>
</FRAMESET>
<FRAMESET ROWS='100%,0%'>
<FRAME SRC='background.htm' SCROLLING='no' NORESIZE>
</FRAMESET>
</FRAMESET>
<BODY BGCOLOR='#FFFFFF0' TEXT='#000070' LINK='#0000ff' ALINK='#FF0000' VLINK='#007986'>
</BODY>
</HTML>

```

16 - logoicon1.htm

```

<HTML>
<HEAD>
<TITLE>Logo Icon 1</TITLE>
</HEAD>
<BODY BGCOLOR='#FFFFFF0' TEXT='#000070' LINK='#0000ff' ALINK='#FF0000' VLINK='#007986'>
<CENTER>
<A HREF='http://209.157.0.2/servlets/logoicon1?zip=951342111' TARGET='_blank'><IMG SRC='hww1.gif' B
ORDER=0></A>
</CENTER>
</BODY>
</HTML>

```

17 - logoname1.htm

```

<HTML>
<HEAD>
<TITLE>Logo Name 1</TITLE>
</HEAD>
<BODY BGCOLOR='#FFFFFF0' TEXT='#000070' LINK='#0000ff' ALINK='#FF0000' VLINK='#007986'>
<CENTER>
<A HREF='http://209.157.0.2/servlets/logoicon1?zip=951342111' target='_blank'>Home Wide Web</A>
</CENTER>
</BODY>
</HTML>

```

18 - logoicon2.htm

```

<HTML>
<HEAD>
<TITLE>Logo Icon 2</TITLE>
</HEAD>
<BODY BGCOLOR='#FFFFFF0' TEXT='#000070' LINK='#0000ff' ALINK='#FF0000' VLINK='#007986'>
<BR><BR>
<CENTER>
<A HREF='http://204.71.200.75/servlets/logoicon1?zip=951342111' TARGET='_blank'><IMG SRC='yahoo.gif'
BORDER=0></A>
</CENTER>

```

```

</BODY>
</HTML>
  19 - logoname2.htm
<HTML>
<HEAD>
<TITLE>Logo Name 2</TITLE>
</HEAD>
<BODY BGCOLOR='#FFFFFF0' TEXT='#000070' LINK='#0000ff' ALINK='#FF0000' VLINK='#007986'>
<CENTER>
<A HREF='http://204.71.200.75/servlets/logoicon1?zip=951342111' TARGET='_blank'>Directory Services</
A>
</CENTER>
</BODY>
</HTML>

```

```

  20 -
<HTML>
<HEAD>
<TITLE>HN Devices Page</TITLE>
</HEAD>
<FRAMESET ROWS='2%, 47%,2%, 22.5%,2%,22.5%, 2%' BORDER=0 COLOR=black>
<NOFRAMES>Sorry does not support frames</NOFRAMES>
<FRAMESET ROWS='100%,0%'>
<FRAME SRC='background.htm' SCROLLING='no' NORESIZE>
</FRAMESET>
<FRAMESET COLS='1.2%,23.5%,1.2%,48.2%,1.2%,23.5%,1.2%'>
<FRAMESET ROWS='100%,0%'>
<FRAME SRC=' https://www.homewideweb.com/redirect?https://dongyan.myhomenetwork.com/backgr ound.
htm' SCROLLING='no' NORESIZE>
</FRAMESET>
<FRAMESET ROWS='48%,4%,48%'>
<FRAMESET ROWS='73%, 27%'>
<FRAME SRC='https://www.homewideweb.com/redirect?https://dongyan.myhomenetwork.com/redirect?http:
//10.1.1.2/icon.htm' SCROLLING='no' NORESIZE>
<FRAME SRC='https://www.homewideweb.com/redirect?https://dongyan.myhomenetwork.com/redirect?http:
//10.1.1.2/name.htm' SCROLLING='no' NORESIZE>
</FRAMESET>
<FRAMESET ROWS='100%,0%'>
<FRAME SRC='https://www.homewideweb.com/redirect?https://dongyan.myhomenetwork.com/background.h
tm' SCROLLING='no' NORESIZE>
</FRAMESET>
<FRAMESET ROWS='73%, 27%' >
<FRAME SRC='https://www.homewideweb.com/redirect?https://dongyan.myhomenetwork.com/r edirect?http
://10.1.1.63/icon.htm' SCROLLING='no' NORESIZE>
<FRAME SRC='https://www.homewideweb.com/redirect?https://dongyan.myhomenetwork.com/redirect?http:
//10.1.1.63/name.htm' SCROLLING='no' NORESIZE>
</FRAMESET>
</FRAMESET>
<FRAMESET ROWS='100%,0%'>
<FRAME SRC='https://www.homewideweb.com/redirect?https://dongyan.myhomenetwork.com/background.h
tm' SCROLLING='no' NORESIZE>
</FRAMESET>
<FRAMESET ROWS='73%, 27%' >
<FRAME SRC='icon.htm' SCROLLING='no' NORESIZE>
<FRAME SRC='name.htm' SCROLLING='no' NORESIZE>
</FRAMESET>
<FRAMESET ROWS='100%,0%'>
<FRAME SRC='https://www.homewideweb.com/redirect?https://dongyan.myhomenetwork.com/b ackground.
htm' SCROLLING='no' NORESIZE>
</FRAMESET>

```

```

<FRAMESET ROWS='48%,4%,48%'\>
<FRAMESET ROWS='73%, 27%' >
<FRAME SRC='http://10.41.1.2/icon.htm' SCROLLING='no' NORESIZE>
<FRAME SRC='http://10.41.1.2/name.htm' SCROLLING='no' NORESIZE>
</FRAMESET>
<FRAMESET ROWS='100%,0%'\>
<FRAME SRC='https://www.homewideweb.com/redirect?https://dongyan.myhomenetwork.com/background.htm' SCROLLING='no' NORESIZE>
</FRAMESET>
<FRAMESET ROWS='73%, 27%' >
<FRAME SRC='https://www.homewideweb.com/redirect?https://dongyan.myhomenetwork.com/redirect?http://10.10.1.2/icon.htm' SCROLLING='no' NORESIZE>
<FRAME SRC='https://www.homewideweb.com/redirect?https://dongyan.myhomenetwork.com/redirect?http://10.10.1.2/name.htm' SCROLLING='no' NORESIZE>
</FRAMESET>
</FRAMESET>
<FRAMESET ROWS='100%,0%'\>
<FRAME SRC='https://www.homewideweb.com/redirect?https://dongyan.myhomenetwork.com/background.htm' SCROLLING='no' NORESIZE>
</FRAMESET>
</FRAMESET>
<FRAMESET ROWS='100%,0%'\>
<FRAME SRC='https://www.homewideweb.com/redirect?https://dongyan.myhomenetwork.com/background.htm' SCROLLING='no' NORESIZE>
</FRAMESET>
<FRAMESET COLS='1.2%,23.5%,1.2%,23.5%,1.2%,23.5%,1.2%,23.5%,1.2%'\>
<FRAMESET ROWS='100%,0%'\>
<FRAME SRC='https://www.homewideweb.com/redirect?https://dongyan.myhomenetwork.com/background.htm' SCROLLING='no' NORESIZE>
</FRAMESET>
<FRAMESET ROWS='73%, 27%' >
<FRAME SRC='https://www.homewideweb.com/redirect?https://dongyan.myhomenetwork.com/redirect?http://10.1.1.200/icon.htm' SCROLLING='no' NORESIZE>
<FRAME SRC='https://www.homewideweb.com/redirect?https://dongyan.myhomenetwork.com/redirect?http://10.1.1.200/name.htm' SCROLLING='no' NORESIZE>
</FRAMESET>
<FRAMESET ROWS='100%,0%'\>
<FRAME SRC='https://www.homewideweb.com/redirect?https://dongyan.myhomenetwork.com/background.htm' SCROLLING='no' NORESIZE>
</FRAMESET>
<FRAMESET ROWS='73%, 27%' >
<FRAME SRC='https://www.homewideweb.com/redirect?https://dongyan.myhomenetwork.com/redirect?http://10.1.10.20/icon.htm' SCROLLING='no' NORESIZE>
<FRAME SRC='https://www.homewideweb.com/redirect?https://dongyan.myhomenetwork.com/redirect?http://10.1.10.20/name.htm' SCROLLING='no' NORESIZE>
</FRAMESET>
<FRAMESET ROWS='100%,0%'\>
<FRAME SRC='https://www.homewideweb.com/redirect?https://dongyan.myhomenetwork.com/background.htm' SCROLLING='no' NORESIZE>
</FRAMESET>
<FRAMESET ROWS='73%, 27%' >
<FRAME SRC='https://www.homewideweb.com/redirect?https://dongyan.myhomenetwork.com/redirect?http://10.1.99.2/icon.htm' SCROLLING='no' NORESIZE>
<FRAME SRC='https://www.homewideweb.com/redirect?https://dongyan.myhomenetwork.com/redirect?http://10.1.99.2/name.htm' SCROLLING='no' NORESIZE>
</FRAMESET>
<FRAMESET ROWS='100%,0%'\>
<FRAME SRC='https://www.homewideweb.com/redirect?https://dongyan.myhomenetwork.com/background.htm' SCROLLING='no' NORESIZE>

```



```

</FRAMESET>
<FRAMESET ROWS='73%, 27%' >
<FRAME SRC='https://www.homewideweb.com/redirect?https://dongyan.myhomenetwork.com/redirect?http:
//10.1.99.9/icon.htm' SCROLLING='no' NORESIZE>
<FRAME SRC='https://www.homewideweb.com/redirect?https://dongyan.myhomenetwork.com/redirect?http:
//10.1.99.9/name.htm' SCROLLING='no' NORESIZE>
</FRAMESET>
<FRAMESET ROWS='100%,0%'>
<FRAME SRC='https://www.homewideweb.com/redirect?https://dongyan.myhomenetwork.com/background.h
tm' SCROLLING='no' NORESIZE>
</FRAMESET>
</FRAMESET>
<FRAMESET ROWS='100%,0%'>
<FRAME SRC='https://www.homewideweb.com/redirect?https://dongyan.myhomenetwork.com/b ackground.
htm' SCROLLING='no' NORESIZE>
</FRAMESET>
<FRAMESET COLS='1.2%,23.5%,1.2%,23.5%,1.2%,23.5%,1.2%,23.5%,1.2%'>
<FRAMESET ROWS='100%,0%'>
<FRAME SRC='https://www.homewideweb.com/redirect?https://dongyan.myhomenetwork.com/background.h
tm' SCROLLING='no' NORESIZE>
</FRAMESET>
<FRAMESET ROWS='73%, 27%' >
<FRAME SRC='https://www.homewideweb.com/redirect?https://dongyan.myhomenetwork.com/redirect?http:
//209.157.0.2/logoicon1.htm' SCROLLING='no' NORESIZE>
<FRAME SRC='https://www.homewideweb.com/redirect?https://dongyan.myhomenetwork.com/redirect?http:
//209.157.0.2/logoname1.htm' SCROLLING='no' NORESIZE>
</FRAMESET>
<FRAMESET ROWS='100%,0%'>
<FRAME SRC='https://www.homewideweb.com/redirect?https://dongyan.myhomenetwork.com/b ackground.
htm' SCROLLING='no' NORESIZE>
</FRAMESET>
<FRAMESET ROWS='73%, 27%' >
<FRAME SRC='https://www.homewideweb.com/redirect?https://dongyan.myhomenetwork.com/redirect?http:
//209.157.0.2/logoicon2.htm' SCROLLING='no' NORESIZE>
<FRAME SRC='https://www.homewideweb.com/redirect?https://dongyan.myhomenetwork.com/redirect?http:
//209.157.0.2/logoname2.htm' SCROLLING='no' NORESIZE>
</FRAMESET>
<FRAMESET ROWS='100%,0%'>
<FRAME SRC='https://www.homewideweb.com/redirect?https://dongyan.myhomenetwork.com/background.h
tm' SCROLLING='no' NORESIZE>
</FRAMESET>
<FRAMESET ROWS='73%, 27%' >
<FRAME SRC='https://www.homewideweb.com/redirect?https://dongyan.myhomenetwork.com/redirect?http:
//209.157.0.2/logoicon3.htm' SCROLLING='no' NORESIZE>
<FRAME SRC='https://www.homewideweb.com/redirect?https://dongyan.myhomenetwork.com/redirect?http:
//209.157.0.2/logoname3.htm' SCROLLING='no' NORESIZE>
</FRAMESET>
<FRAMESET ROWS='100%,0%'>
<FRAME SRC='https://www.homewideweb.com/redirect?https://dongyan.myhomenetwork.com/background.h
tm' SCROLLING='no' NORESIZE>
</FRAMESET>
<FRAMESET ROWS='73%, 27%' >
<FRAME SRC='https://www.homewideweb.com/redirect?https://dongyan.myhomenetwork.com/redirect?http:
//209.157.0.2/logoicon4.htm' SCROLLING='no' NORESIZE>
<FRAME SRC='https://www.homewideweb.com/redirect?https://dongyan.myhomenetwork.com/redirect?http:
//209.157.0.2/logoname4.htm' SCROLLING='no' NORESIZE>
</FRAMESET>
<FRAMESET ROWS='100%,0%'>

```

```
<FRAME SRC='https://www.homewideweb.com/redirect?https://dongyan.myhomenetwork.com/background.htm' SCROLLING='no' NORESIZE>
</FRAMESET>
</FRAMESET>
<FRAMESET ROWS='100%,0%'>
<FRAME SRC='https://www.homewideweb.com/redirect?https://dongyan.myhomenetwork.com/background.htm' SCROLLING='no' NORESIZE>
</FRAMESET>
</FRAMESET>
<BODY BGCOLOR='#FFFFFF0' TEXT='#000070' LINK='#0000ff' ALINK='#FF0000' VLINK='#007986'>
</BODY>
</HTML>
```

21 - background.htm

```
<HTML>
<HEAD>
<TITLE>Background</TITLE>
</HEAD>
<BODY BGCOLOR='#007986'></BODY>
</HTML>
```

22 - icon.htm

```
<HTML>
<HEAD>
<TITLE>Device Icon</TITLE>
</HEAD>
<BODY BGCOLOR='#FFFFFF0' TEXT='#000070' LINK='#0000ff' ALINK='#FF0000' VLINK='#007986'>
<BR><BR>
<CENTER>
<A HREF=' https://www.homewideweb.com/redirect?https://dongyan.myhomenetwork.com/redirect?http://209.157.0.2/index.htm' TARGET='_blank'><IMG SRC='icon.gif' BORDER=0></A>
</CENTER>
</BODY>
</HTML>
```

23 - name.htm

```
<HTML>
<HEAD>
<TITLE>Device Name</TITLE>
</HEAD>
<BODY BGCOLOR='#FFFFFF0' TEXT='#000070' LINK='#0000ff' ALINK='#FF0000' VLINK='#007986'>
<CENTER>
<FONT SIZE=+0>HDTV Master Bedroom</FONT></CENTER>
</BODY>
</HTML>
```

(57)

1.
 - 1 , 1
 - 1 , 2 1 1
 - (a) 가 2 ;
 - (b) 가 1 2
 - (c) 1 1 1 1
 - 1 (description) 가 ,
 - 2 가 ;

(d) ; 가 2

(e) 가 1 ,

1 2. , 1 1394 , 2 -1394

1 3. ,

1 4. , 2 2

4 5. , 2

4 6. , 2 2

6 7. , 2

1 8. , 1 1 , 1

8 9. , 1

1 10. , 1 1

1 11. , 2 (portal) ;

(b) : 가 1 ; (redir

ect) ;

(d) : 가 ;

11 12. , 1 가 1

11 13. , 1 IP ; 1 IP ;

11 14. , 1 ; 1 ;

(b) 1

(c) ; 가 1

15.

14 ,

(b)

;

(c) 가 1

16.

11 ,

(b)

17.

11 ,

(d)

18.

1 ,

2 가 , 1 가

, 1 ,

19.

18 , 1

(agent)

20.

18 , 1

1

21.

18 , 1

2

22.

1 ,

2

23.

1 , 2

24.

1 ,

2 ;

2 ;

1

25.

1 ,

(f) 가 , 1

(g) 가 ;

2

;

(h) 가

25 26. ,

2

(g) :

가

1

;

26 27. ,

가

1

1

1

가

27 28. ,

1

27 29. ,

1

1

27 30. ,

1

2

27 31. ,

1

가

1

가

1

31 32. ,

(g) :

1

가

1

;

1

1

32 33. ,

(h) :

1

;

가

1

1

26 34. ,

(i)

가

,

(j)

가

;

(k)

가

,

34 35. ,

(l)

가

1

(m)

가

;

;

- (n) 1 ;
- (o) 가 , 가
- ;
- (p) 가 ;
- (q) 가 ;
- (r) 가

36.

가 , 1 ; ;
 1 ; (agent)

- (a) 1 ;
- (b) , 1 ;

가 ,

37.

36 , 1394 , -1394

38.

36 ,

39.

36 ,

2

40.

39 ,

2

41.

39 ,

2

42.

41 ,

43.

36 ,

44.

36 ,

45.

36 ,

(portal) ;

46.

45 , 가 , 가

47.

46 ,

48.

46 ,

49.

46 ,

50.

46 , 1 가 1 가 1

51.

50 , 1 1 IP ; 1 IP 1 IP ;

52.

46 , ;

53.

52 , ;

54.

46 ,

55.

46 ,

56.

46 ,

57.

46 ,

58.

46 , ; ;

59.

36 ,

57 60.

60 61.

60 62.

60 63.

60 64.

60 65.

64 66.

65 67.

60 68.

67 69.

;

,

,

;

;

가

가

가

가

가

;

;

,

,

,

70.

,

1

,

1

1

1

, (a)
; (b)

가
가

;

;

71.

70

,

1394

,

-1394

72.

70

,

73.

70

,

2

74.

73

,

2

75.

73

,

2

76.

75

,

77.

70

,

78.

70

,

(portal)

;

;

79.

78

,

가

,

가
가

80.

79 ,
81.
79 ,
82.
79 ,
83.
79 , 1
가 1 가 1
84.
83 , 1 IP
; 1 IP 1 IP ;
85.
78 ,
86.
78 ,
87.
78 , ;
88.
78 , ;
89.
88 , ;
90.
78 ,
91.
78 ,
92.
70 ,

91 93.

93 94.

94 95.

94 96.

94 97.

94 98.

98 99.

99 100.

93 101.

101 102.

가

가

가

가

가

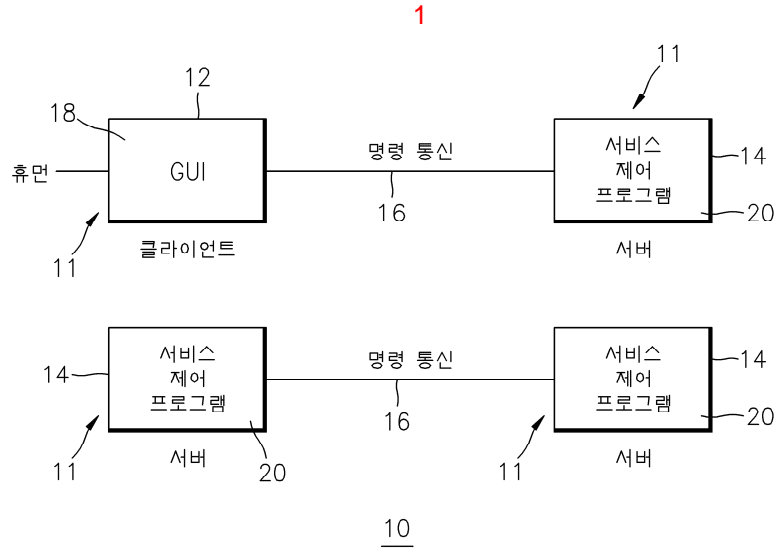

2

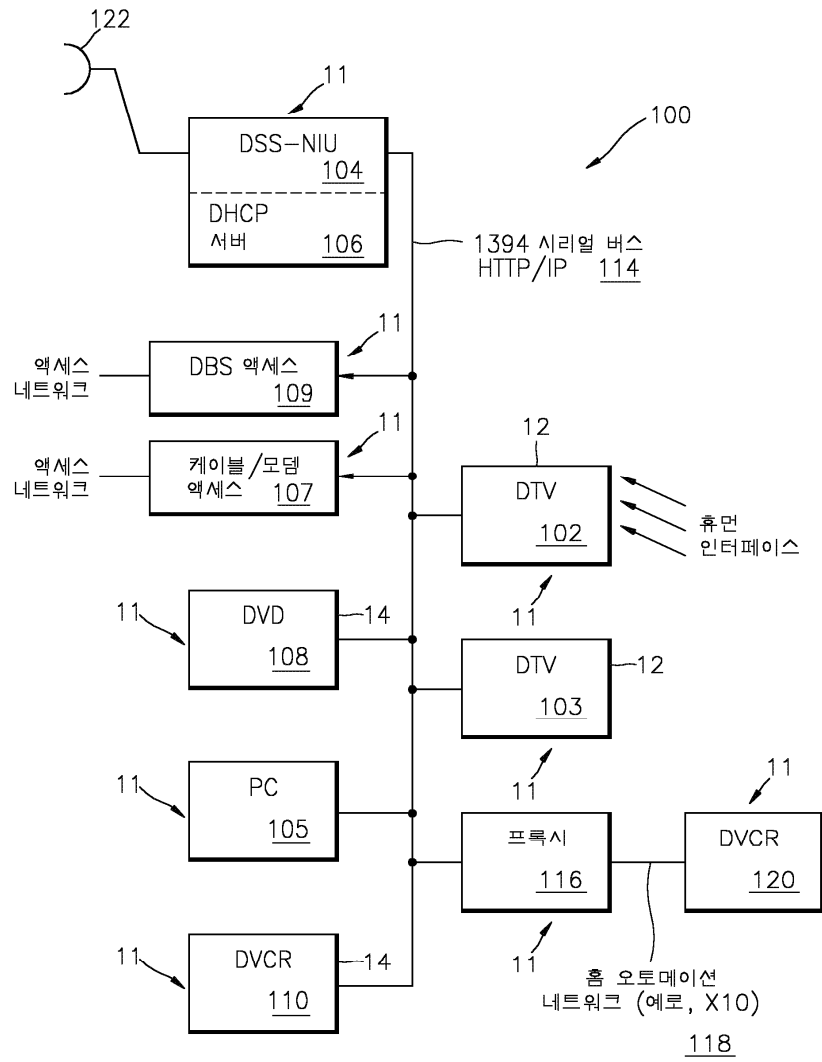

서버 150

애플리케이션층	152
프레젠테이션층	154
세션층	156
트랜스포트층	158
네트워크층	160
데이터 링크층	162
물리층	164

클라이언트 166

애플리케이션층	152
프레젠테이션층	154
세션층	156
트랜스포트층	158
네트워크층	160
데이터 링크층	162
물리층	164

4a

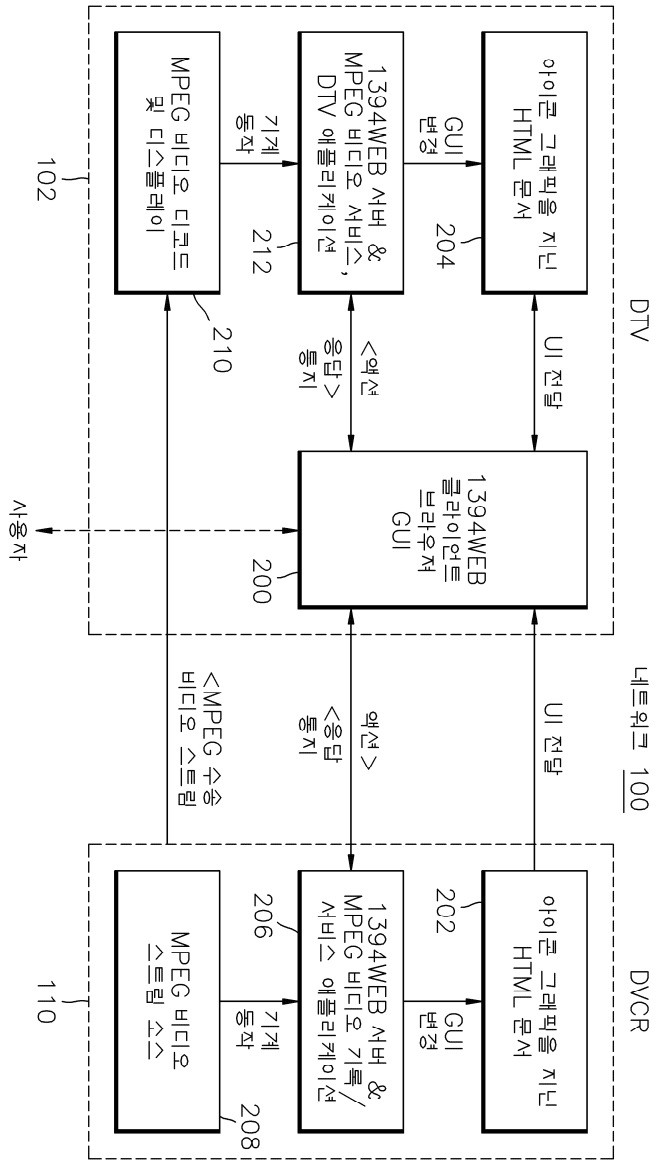

4b

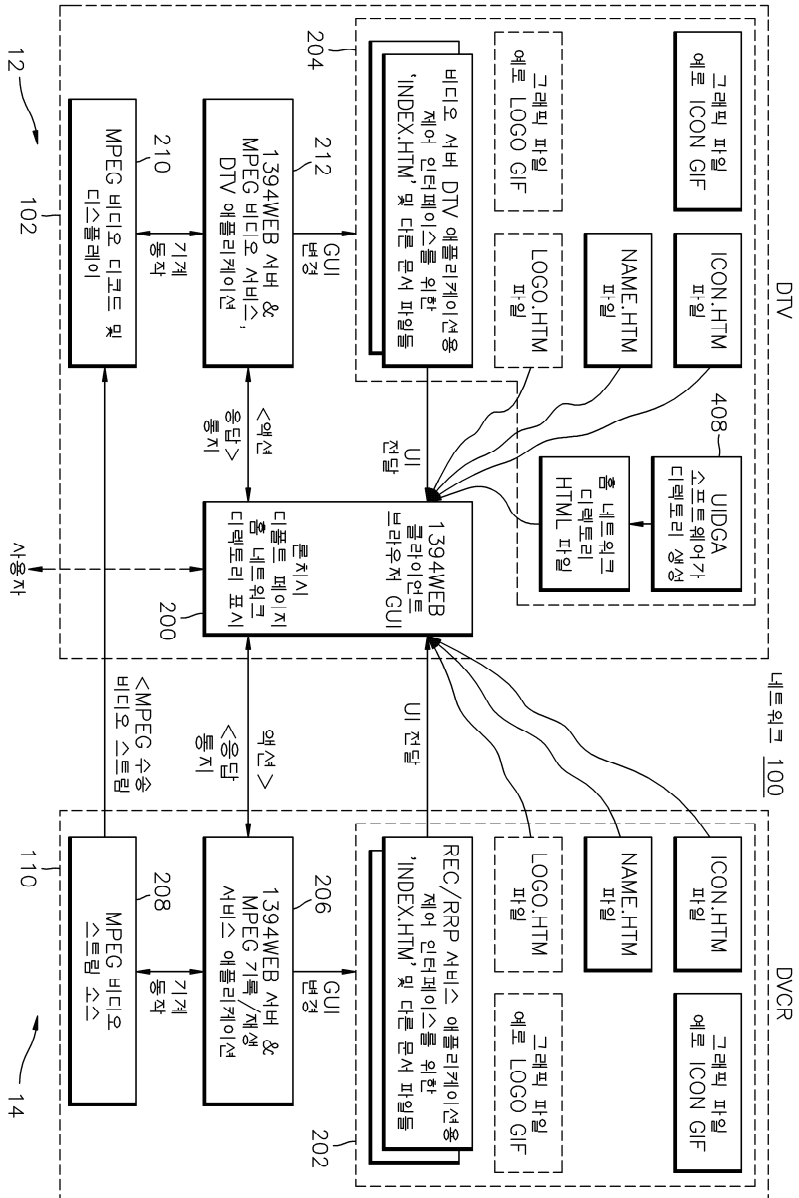

5

220

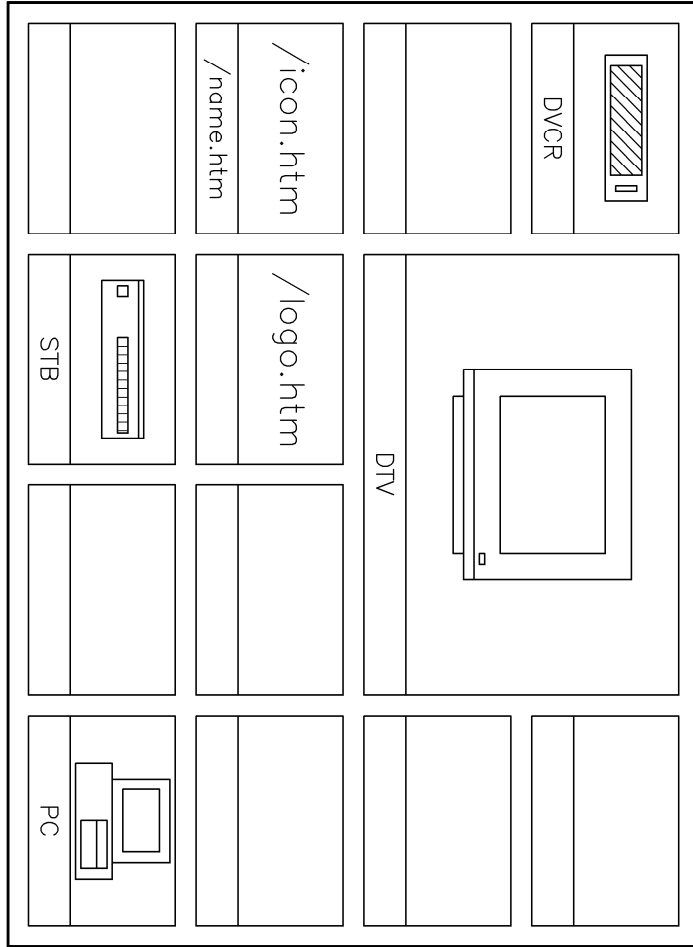

예시적인 네트워크 최상위 레벨 장치 GUI

6

220 →

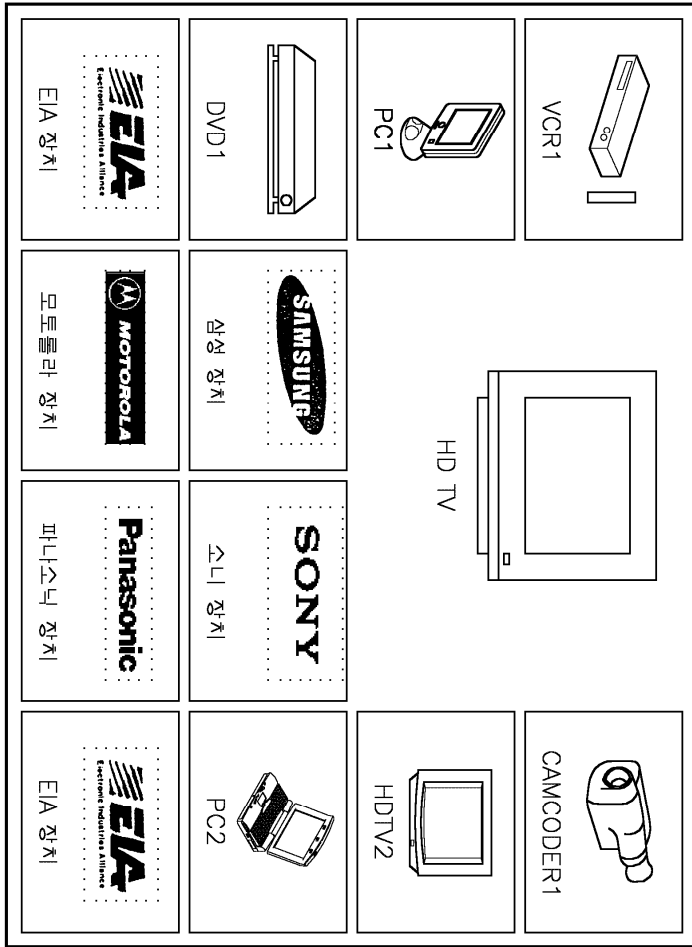

네트워크 최상위 레벨 장치 GUI의 대안적 예

7

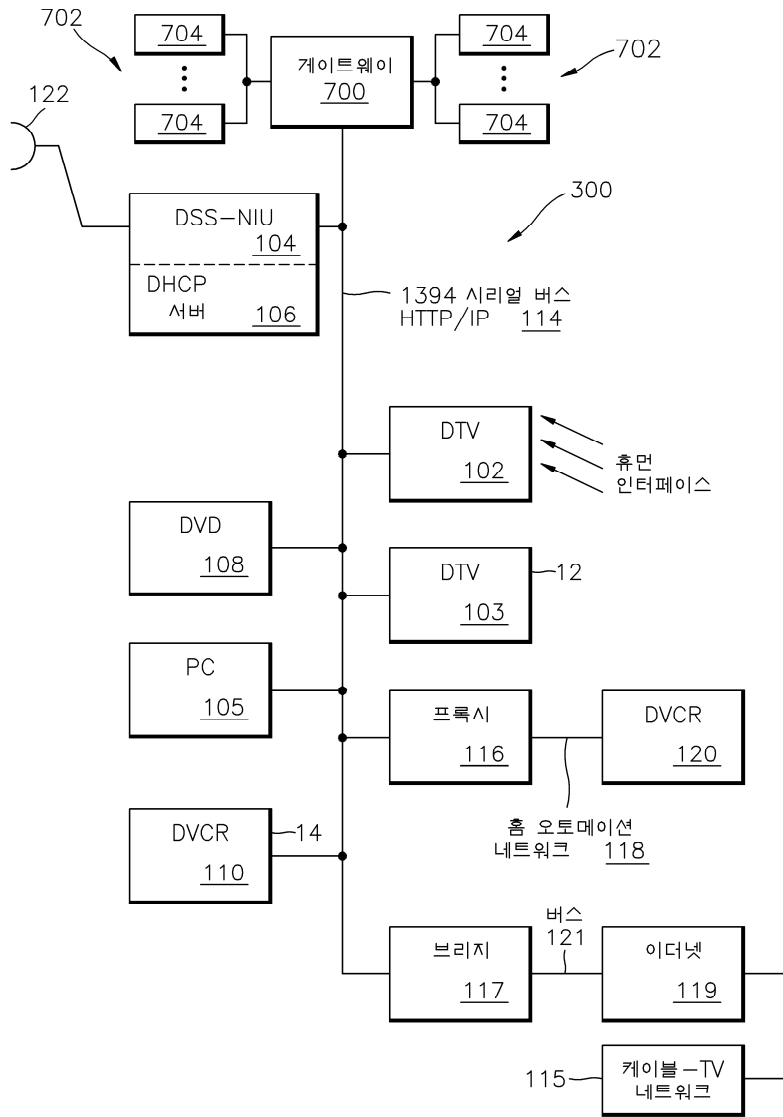

8

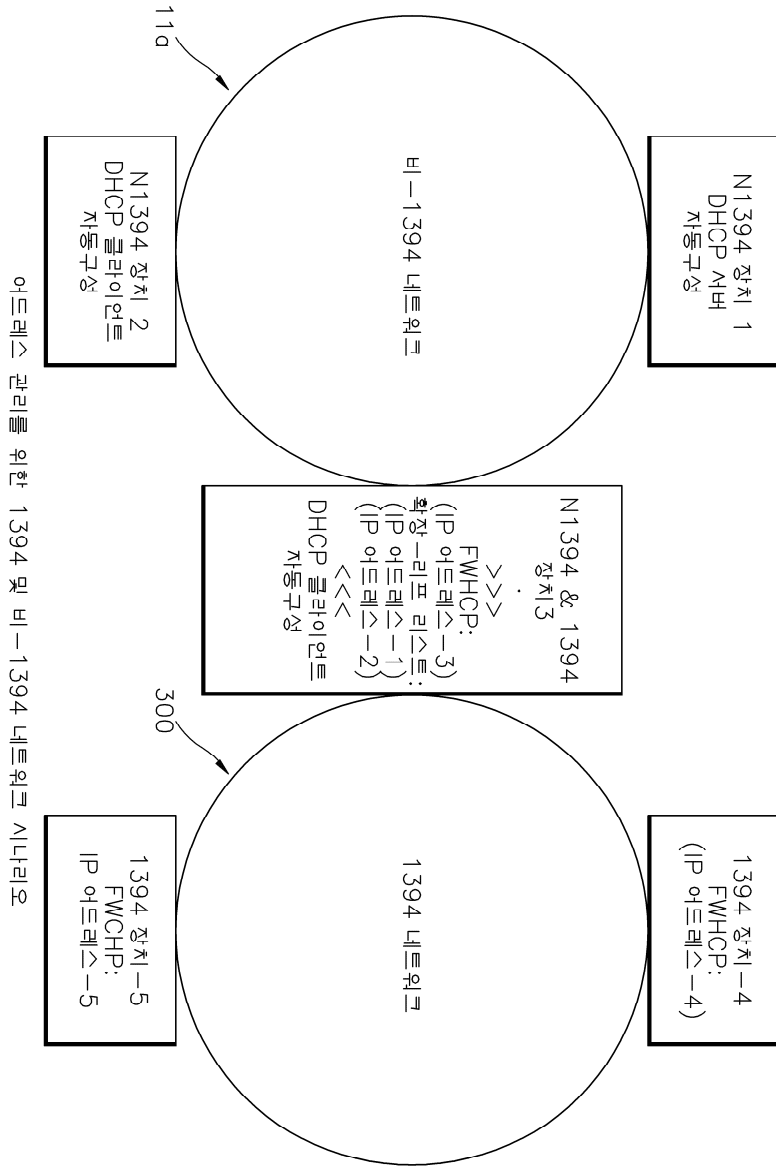

9a

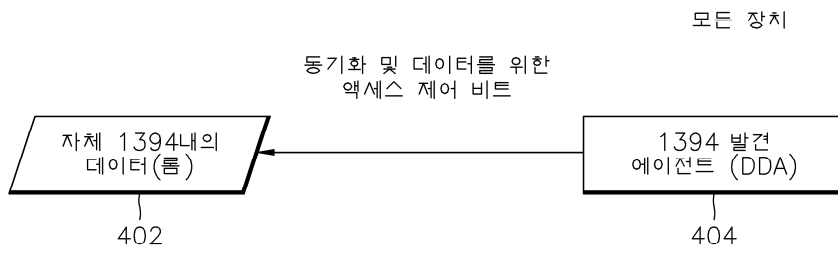

9b

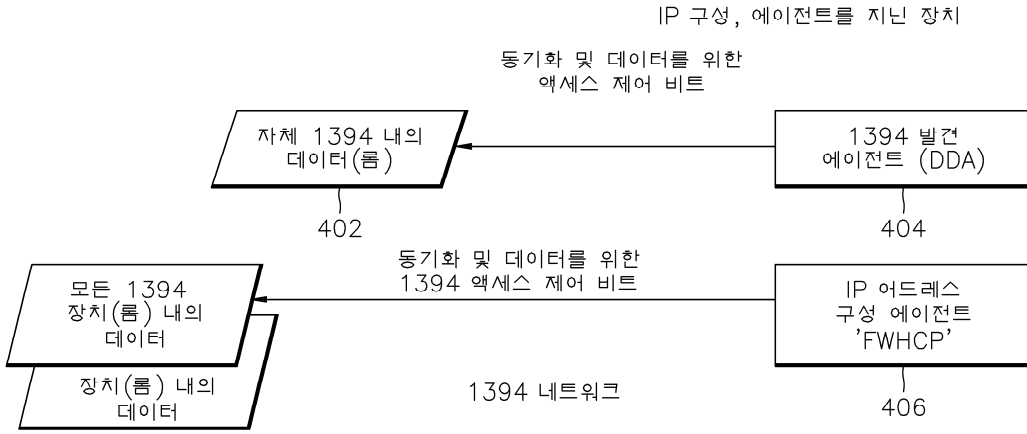

9c

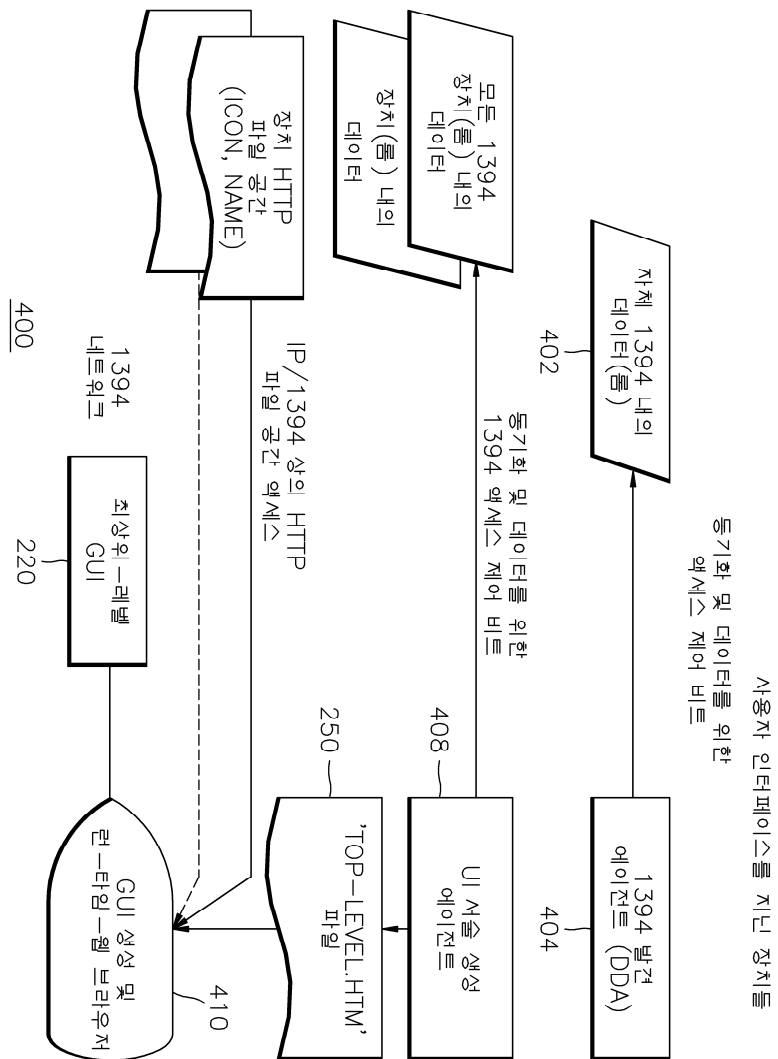

10

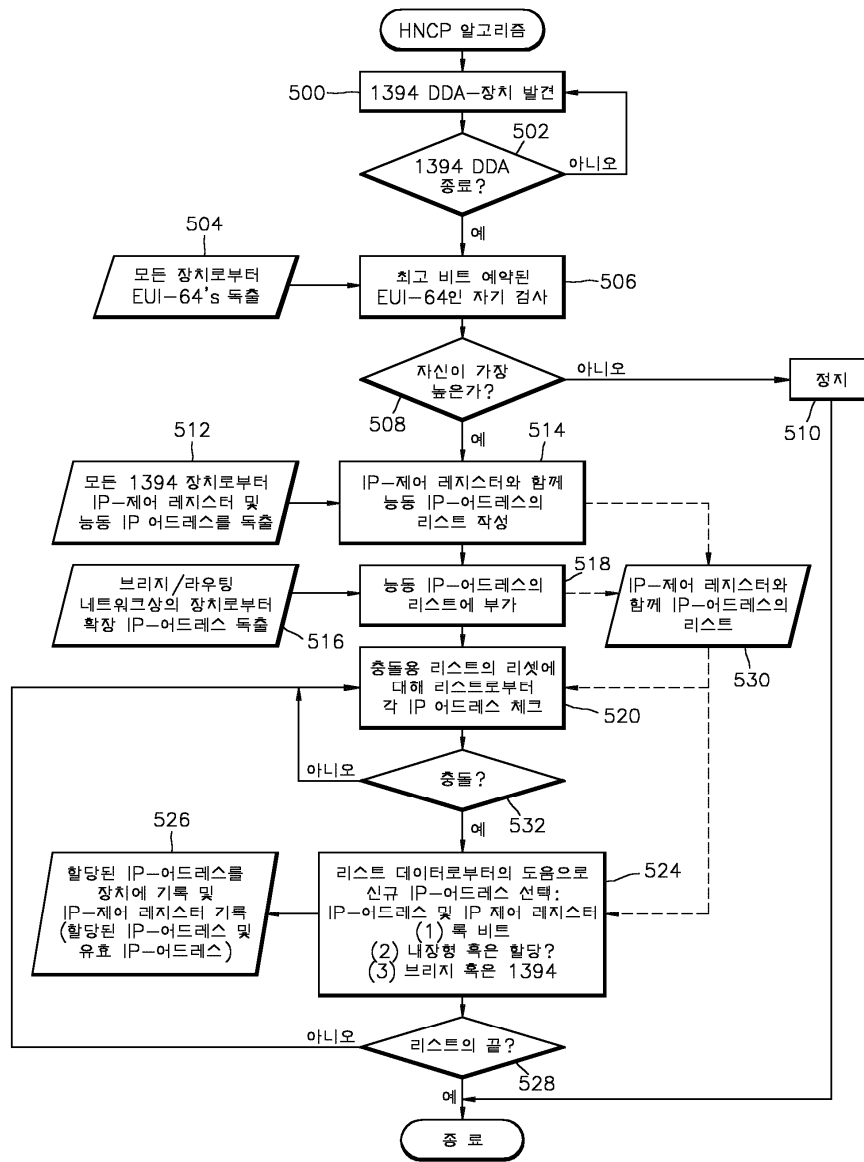

11

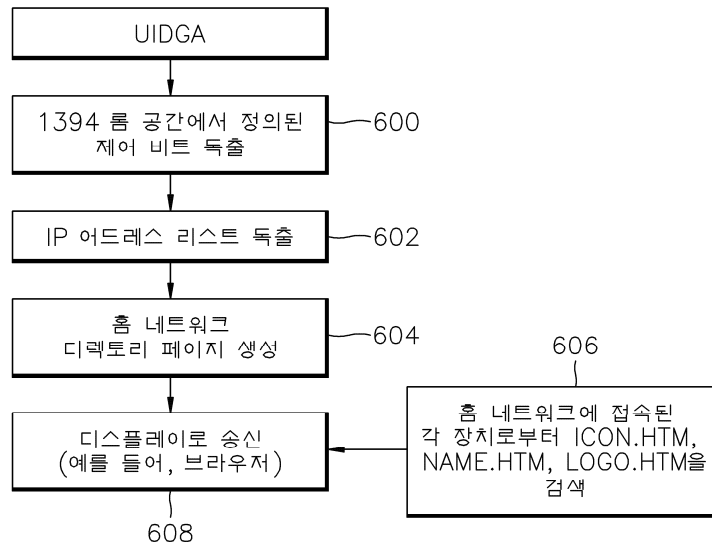

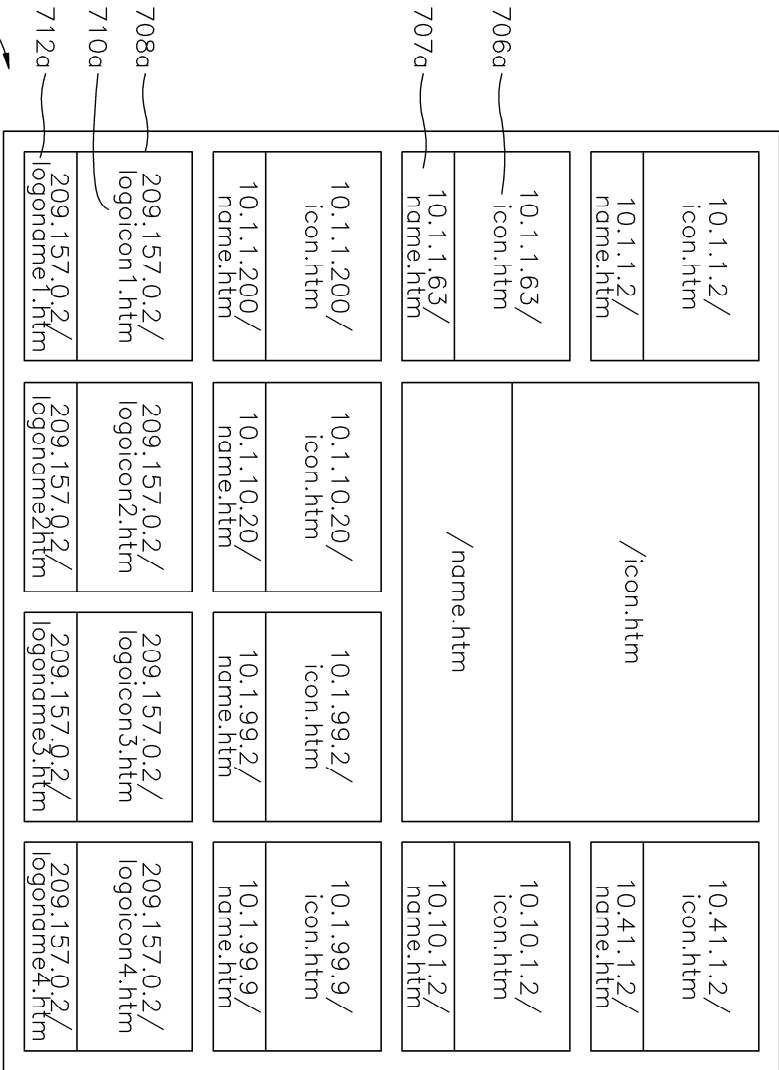

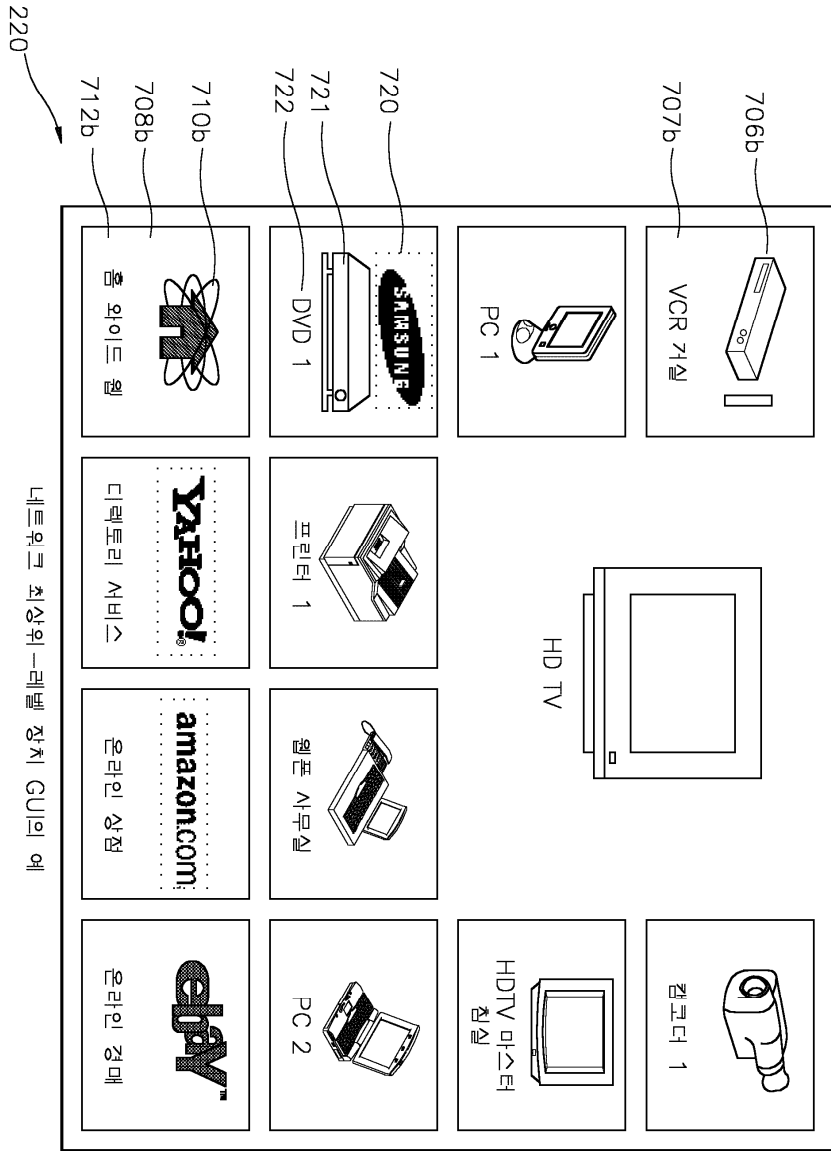

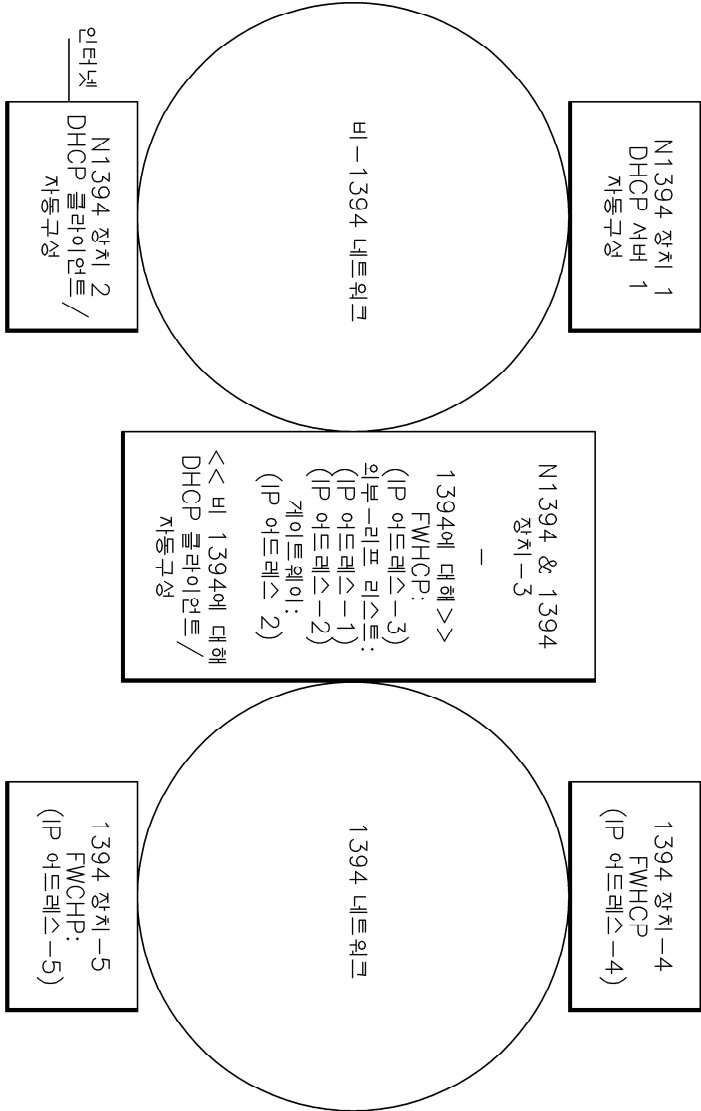

어드레스 관리를 위한 1394 및 비-1394 네트워크 시나리오

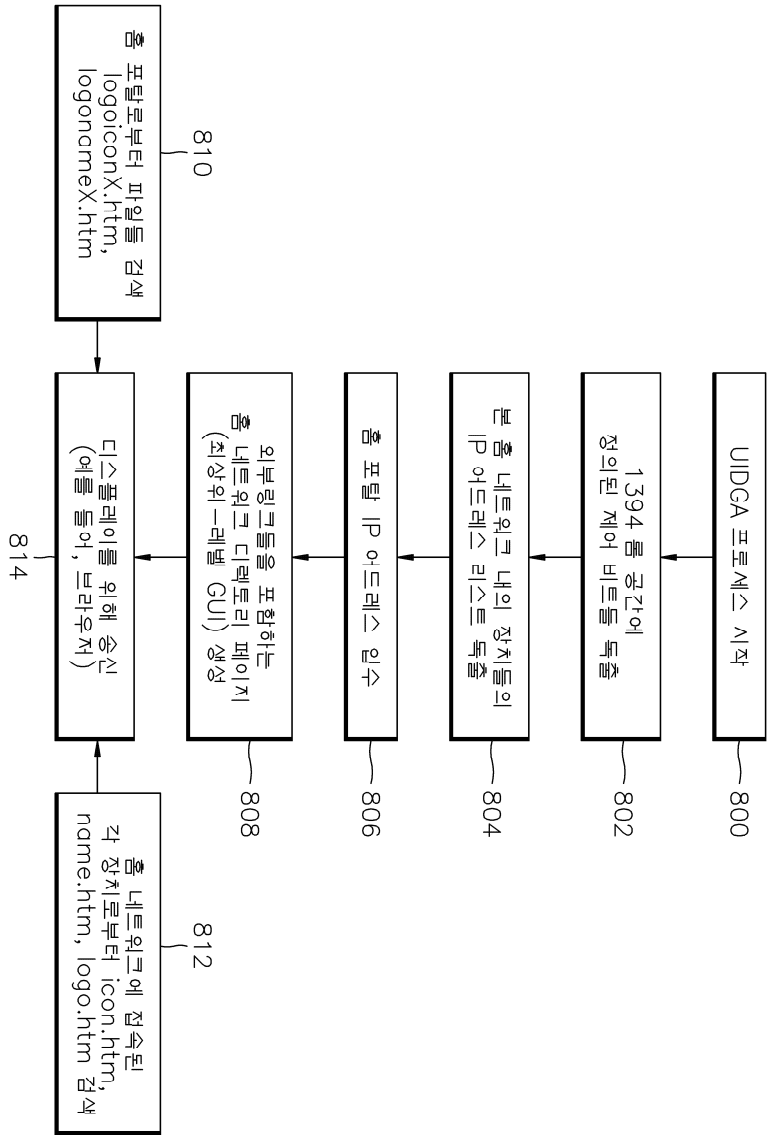

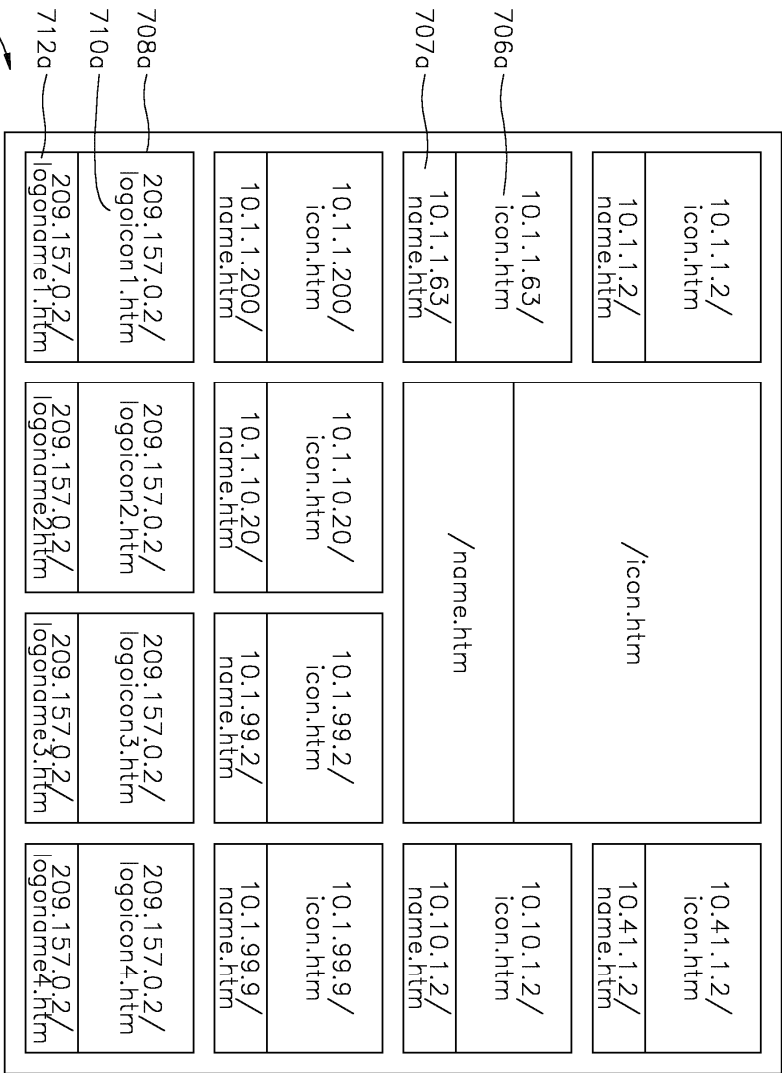

250

네트워크 최상위 레벨 정치를 UI 서술의 예시적인 도식도

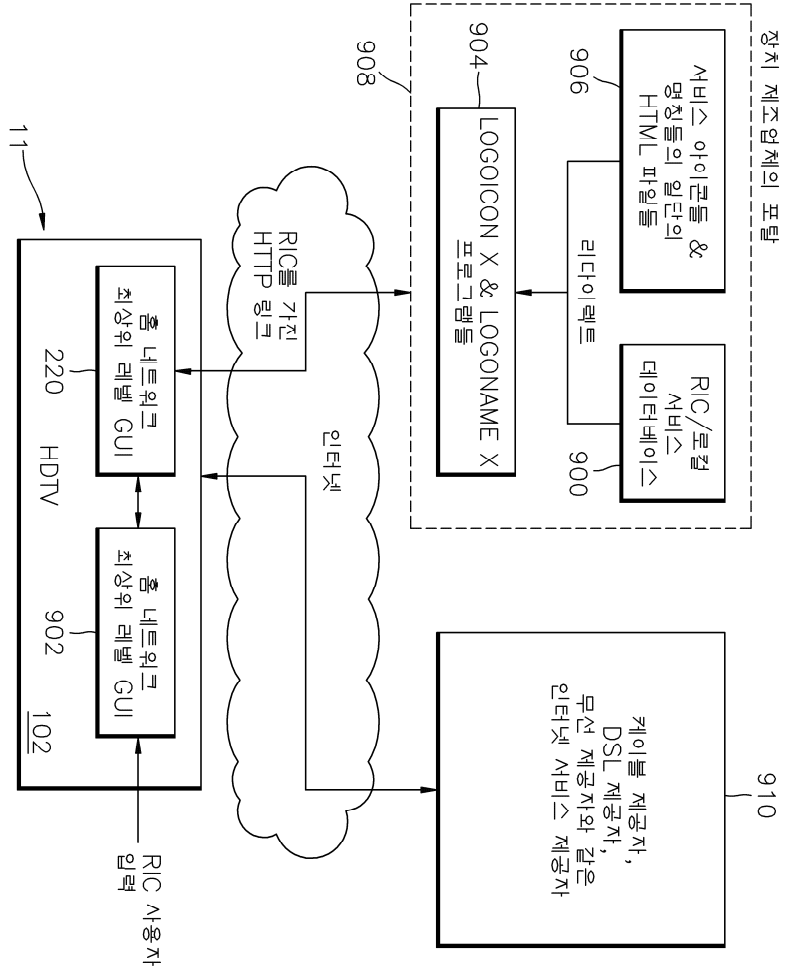

18

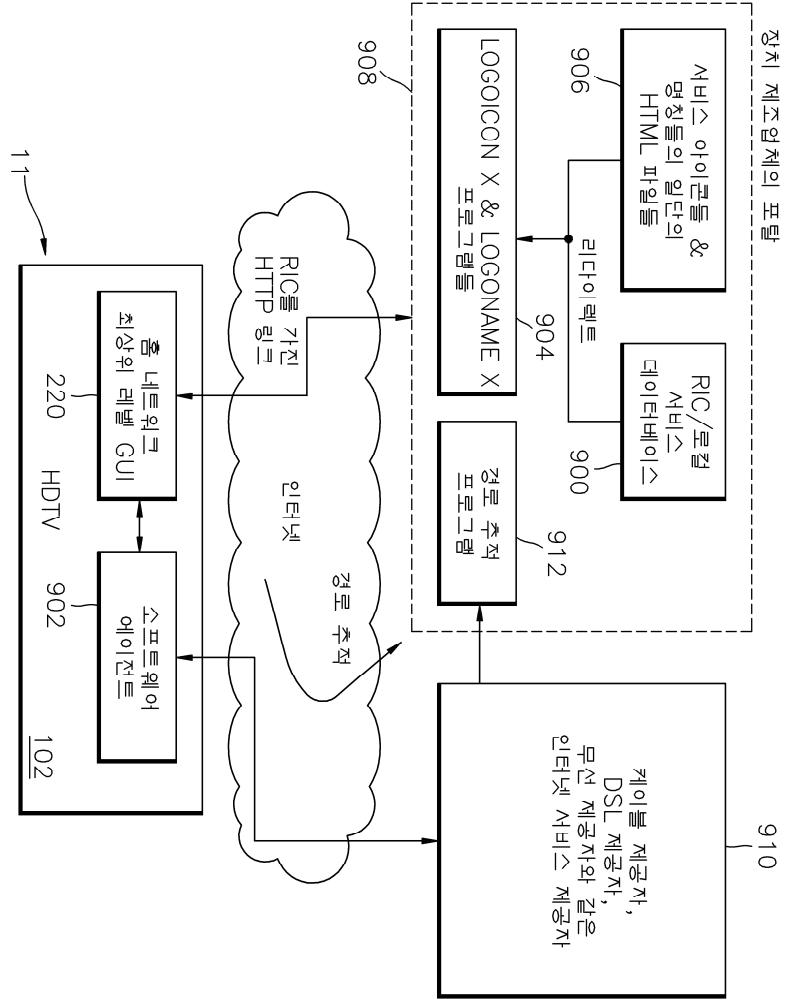

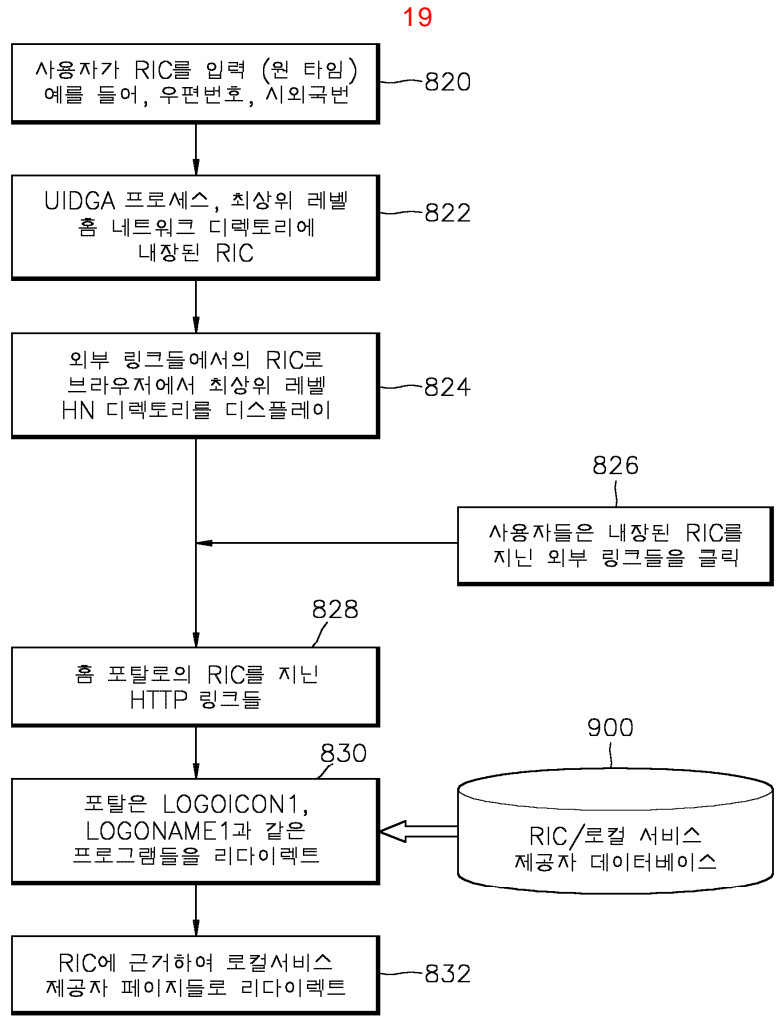

20

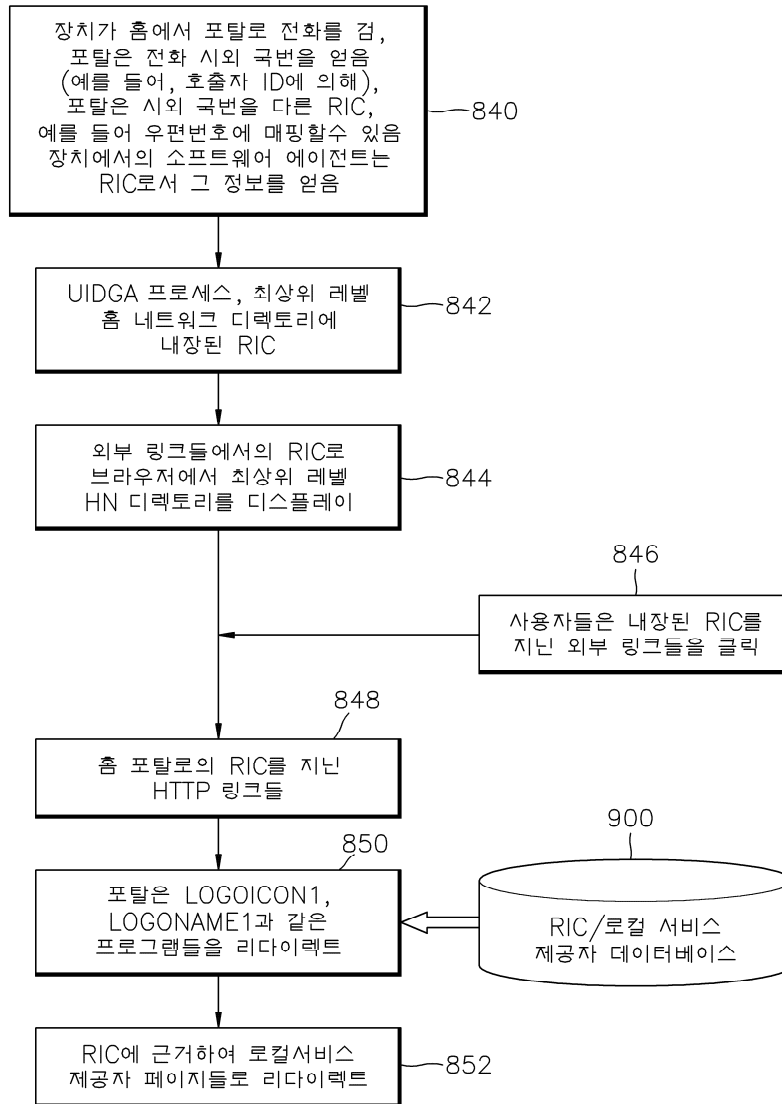

21

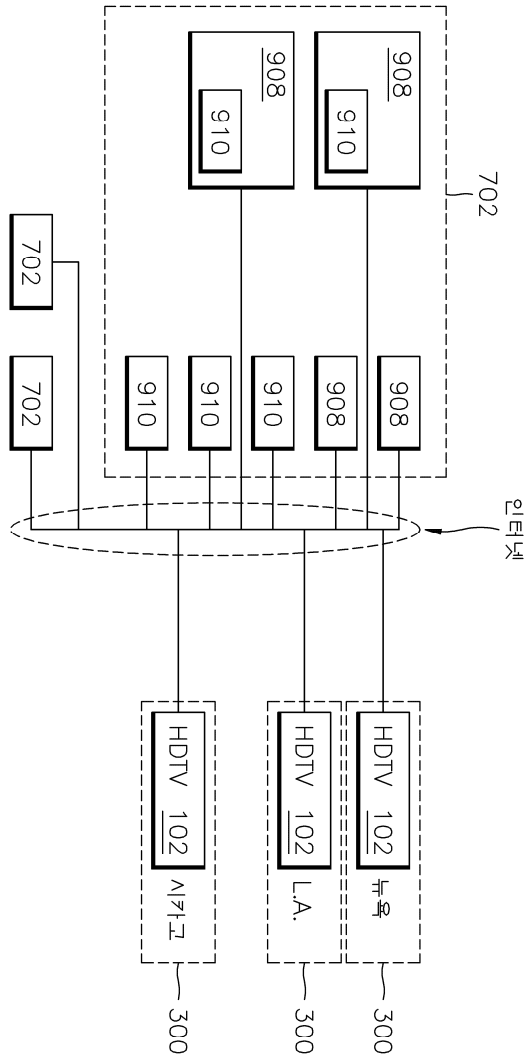

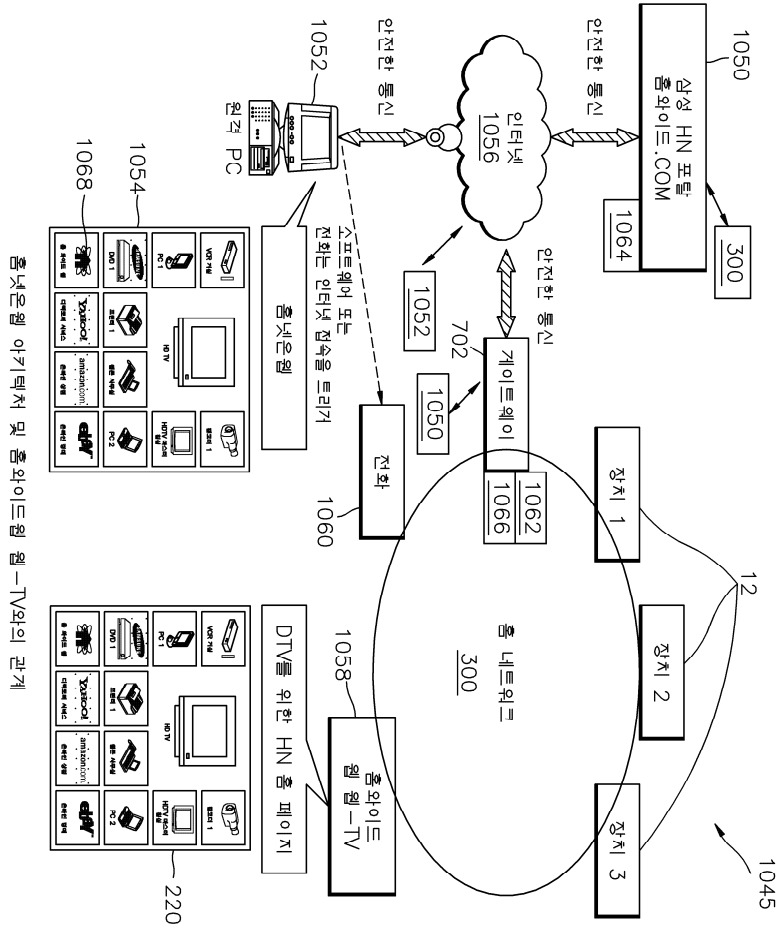

23a

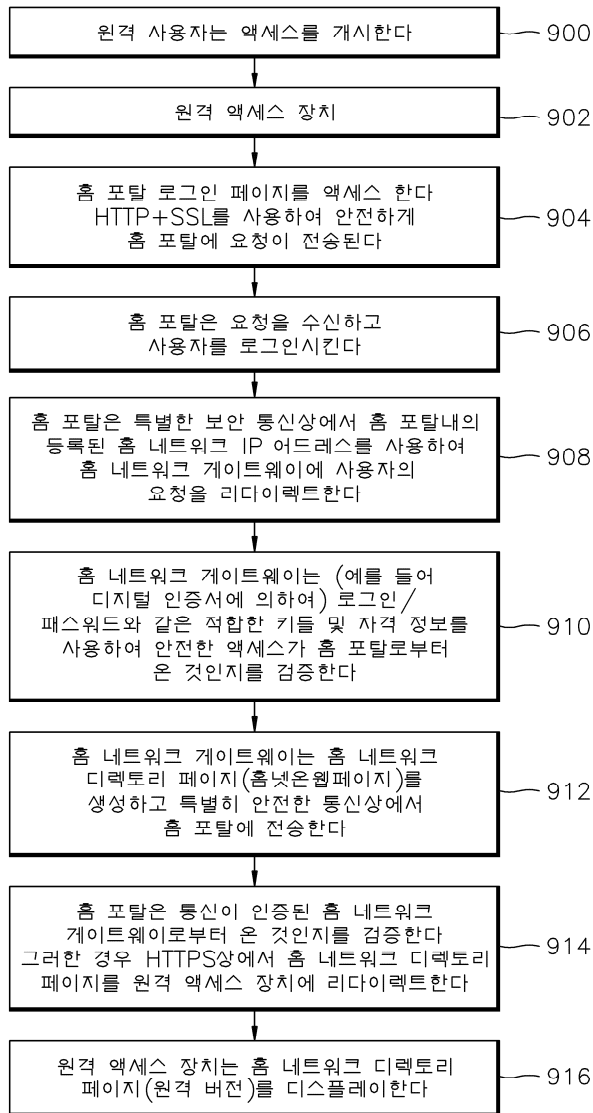

원격 홈넷은웹 디렉토리 페이지를 로딩하기 위한 프로세스

23b

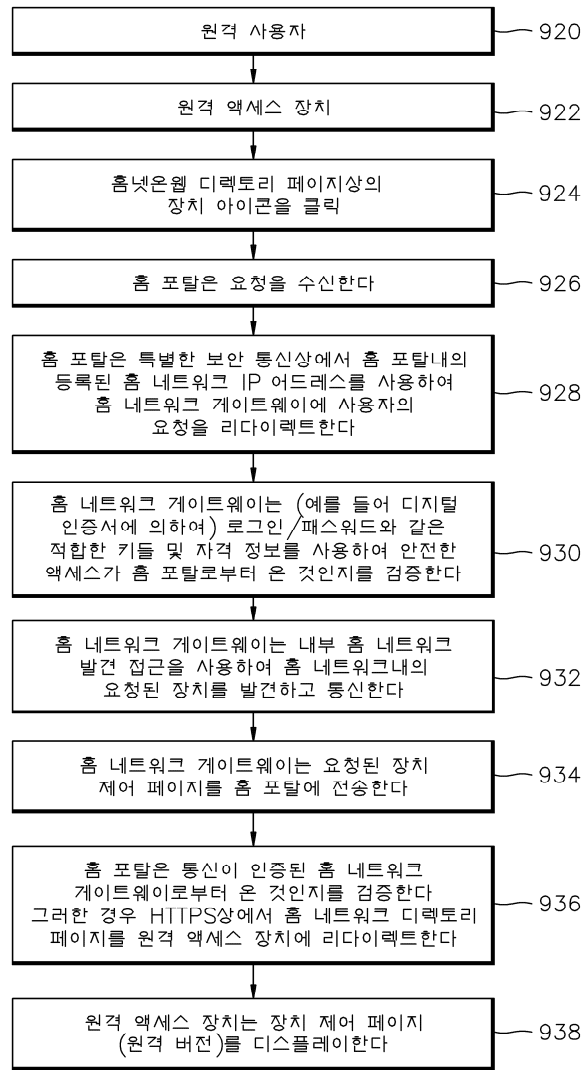

원격 장치로부터 홈 네트워크내의 장치 제어 페이지를 액세스 하기 위한 프로세스 (홈넷온웹 홈 디렉토리 페이지를 로딩한 후)

23c

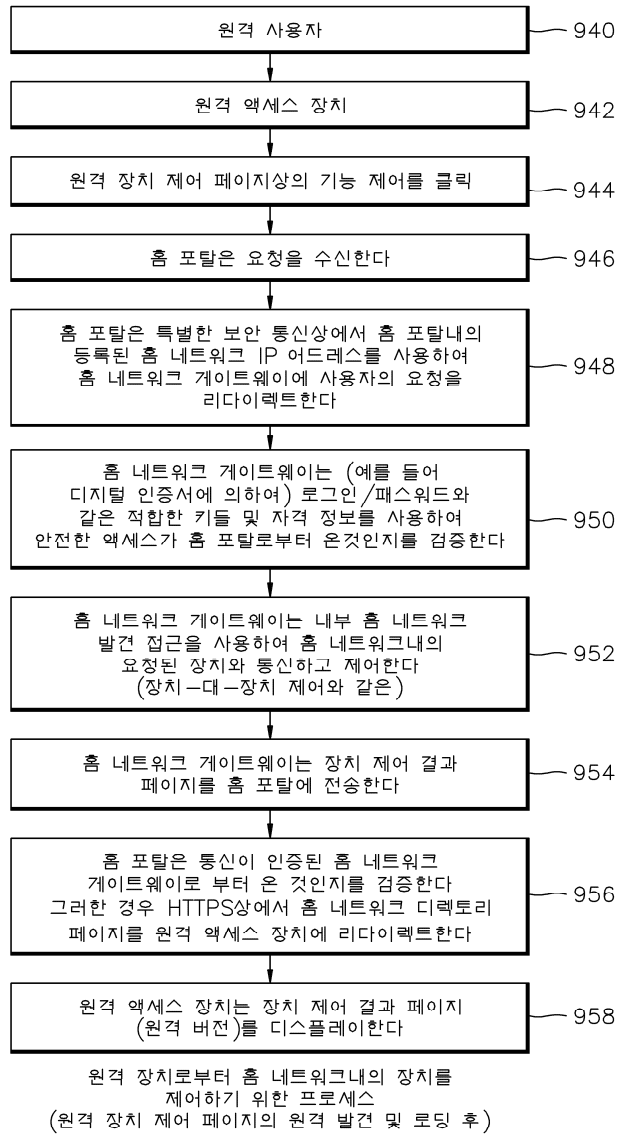

23d

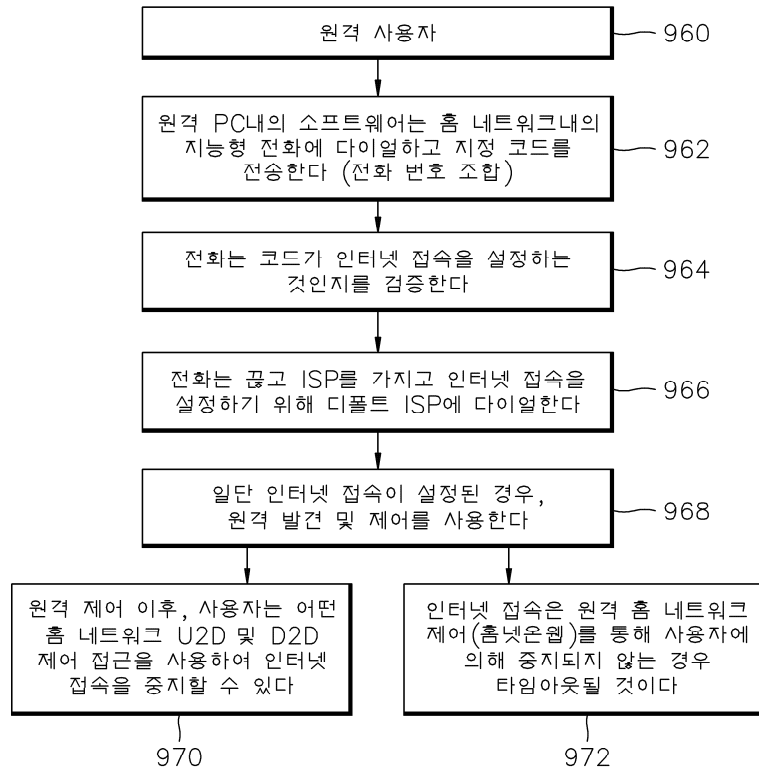

원격 전화 홈 네트워크 접속 활성화

24a

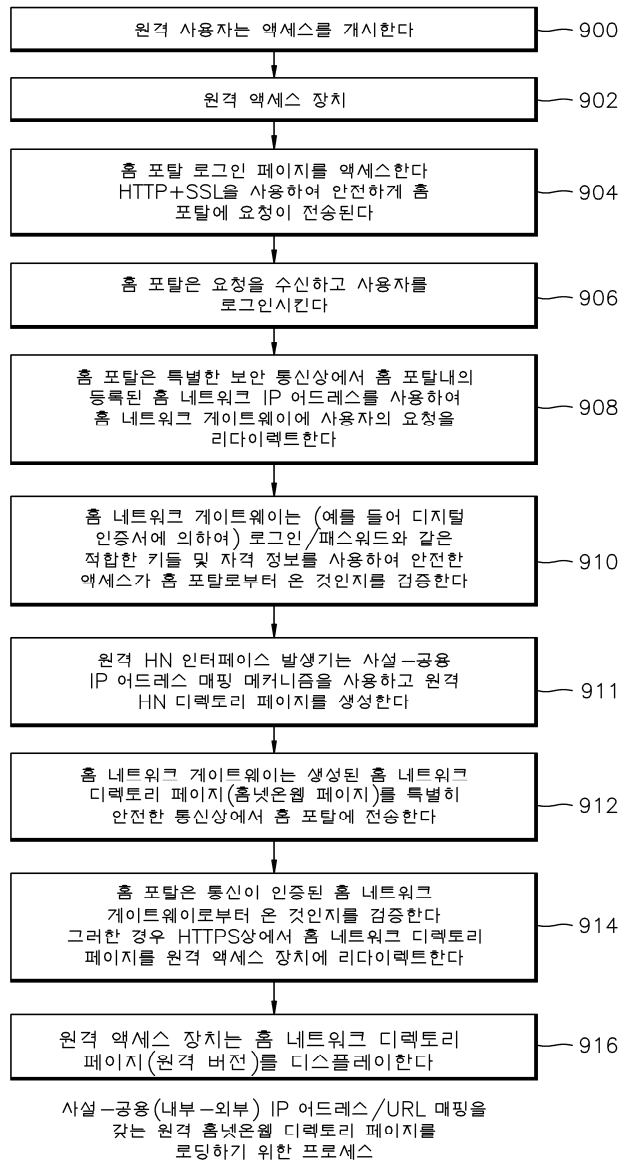

24b

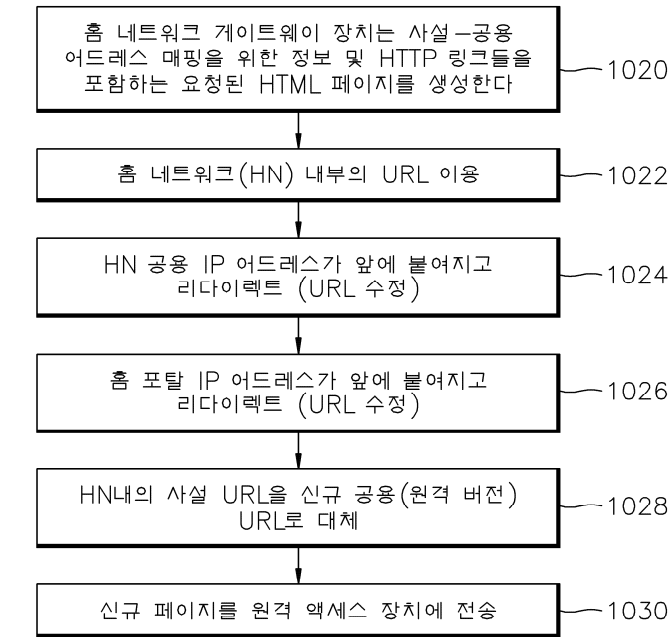

사실-공용 (또는 내부-외부로 지칭) IP 어дрес/URL 매핑을 사용하여 원격 장치에 대한 URL을 생성

24c

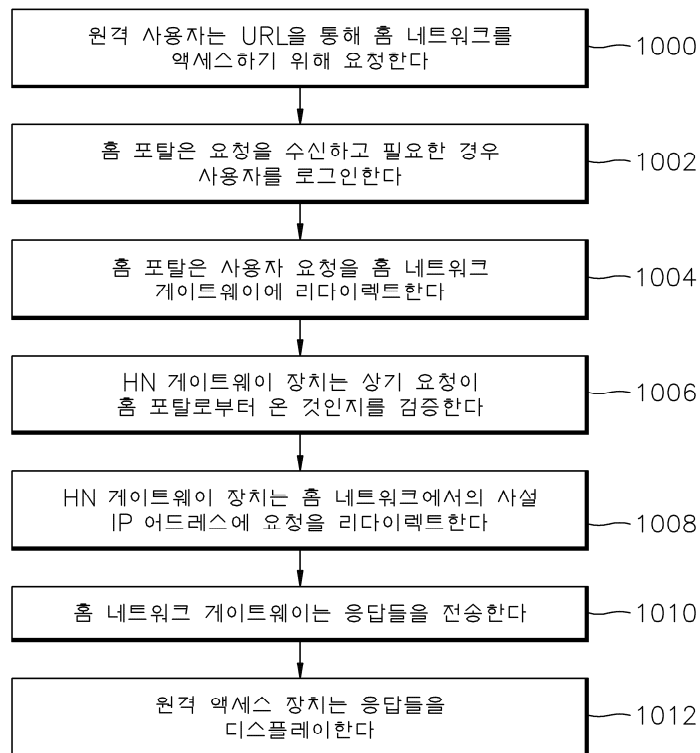

사용자 요청시의 사실-공용 (또는 내부-외부로 지칭) IP 어дрес/URL 매핑