

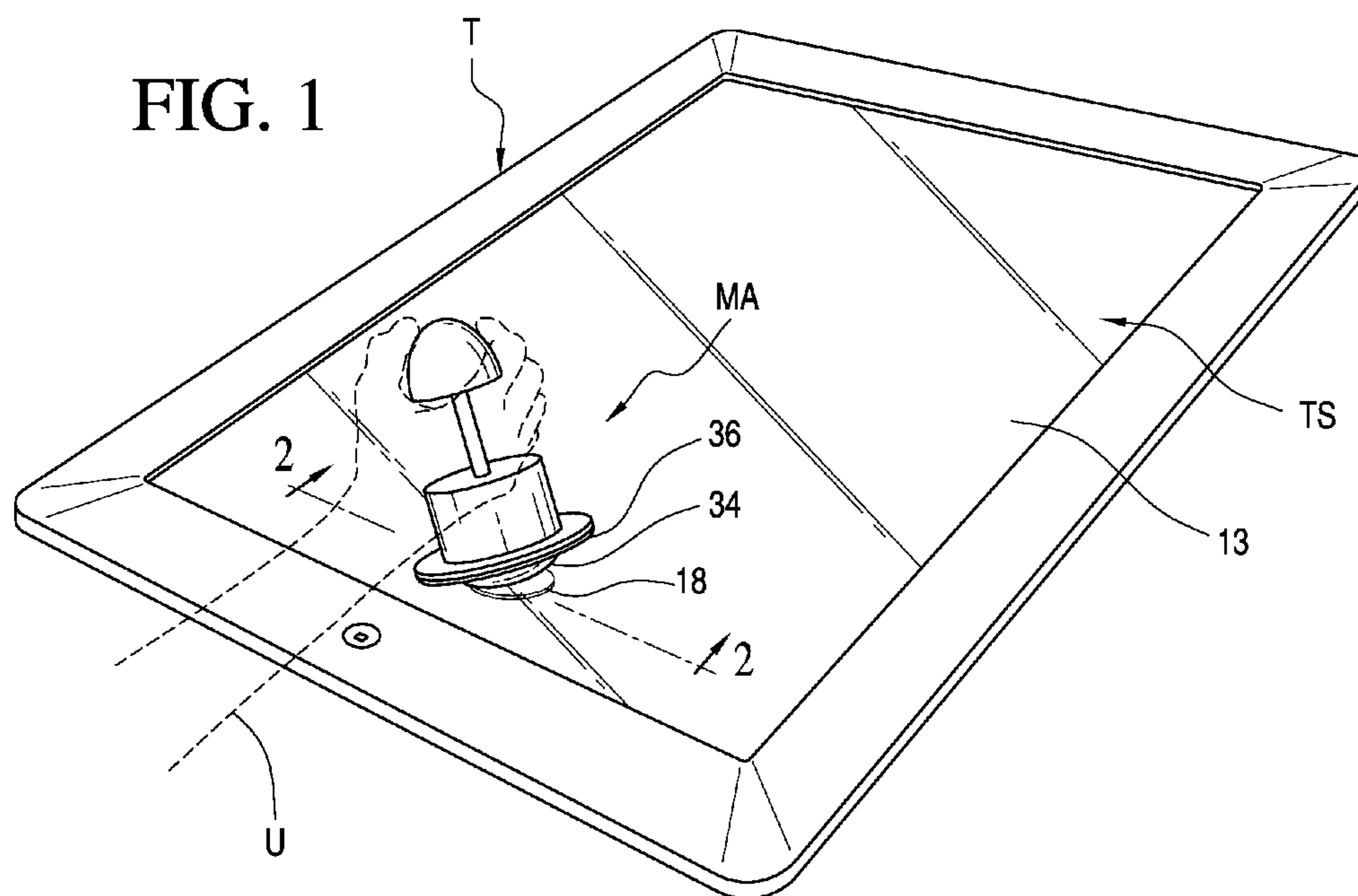

(86) Date de dépôt PCT/PCT Filing Date: 2014/03/02
 (87) Date publication PCT/PCT Publication Date: 2014/09/12
 (85) Entrée phase nationale/National Entry: 2015/09/03
 (86) N° demande PCT/PCT Application No.: US 2014/019756
 (87) N° publication PCT/PCT Publication No.: 2014/137852
 (30) Priorité/Priority: 2013/03/08 (US13/789,807)

(51) Cl.Int./Int.Cl. *G06F 3/0338* (2013.01),
G06F 3/041 (2006.01)
 (71) Demandeur/Applicant:
PETERSEN, DARREN C., US
 (72) Inventeur/Inventor:
PETERSEN, DARREN C., US
 (74) Agent: MCMILLAN LLP

(54) Titre : APPAREIL D'ACTIONNEUR MECANIQUE POUR UN ECRAN TACTILE
 (54) Title: MECHANICAL ACTUATOR APPARATUS FOR A TOUCHSCREEN



(57) **Abrégé/Abstract:**

In combination with an electronic device including a touchscreen with a first user interaction surface and a second surface, a joystick apparatus includes a joystick with a handle portion and a cooperating base portion with an upstanding sleeve. The handle portion includes a skirt portion for operably engaging the sleeve to thereby secure a first magnetic member therebetween. An attachment member is positioned on the second surface of the touchscreen and includes a second magnetic member for engaging the first magnetic member. The base portion of the joystick includes a conductive member for contacting the first user interaction surface of the touchscreen.

(12) INTERNATIONAL APPLICATION PUBLISHED UNDER THE PATENT COOPERATION TREATY (PCT)

(19) World Intellectual Property
Organization
International Bureau(43) International Publication Date
12 September 2014 (12.09.2014)(10) International Publication Number
WO 2014/137852 A1(51) International Patent Classification:
G06F 3/033 (2013.01)

(21) International Application Number:

PCT/US2014/019756

(22) International Filing Date:

2 March 2014 (02.03.2014)

(25) Filing Language:

English

(26) Publication Language:

English

(30) Priority Data:

13/789,807 8 March 2013 (08.03.2013) US

(72) Inventor; and

(71) Applicant : PETERSEN, Darren, C. [US/US]; 57 Franklin Place, Montclair, NJ 07042 (US).

(74) Agent: AGARWAL, Dinesh; Dinesh Agarwal, P.C., 5350 Shawnee Road, Suite 330, Alexandria, VA 22312 (US).

(81) Designated States (*unless otherwise indicated, for every kind of national protection available*): AE, AG, AL, AM, AO, AT, AU, AZ, BA, BB, BG, BH, BN, BR, BW, BY, BZ, CA, CH, CL, CN, CO, CR, CU, CZ, DE, DK, DM, DO, DZ, EC, EE, EG, ES, FI, GB, GD, GE, GH, GM, GT, HN, HR, HU, ID, IL, IN, IR, IS, JP, KE, KG, KN, KP, KR,

KZ, LA, LC, LK, LR, LS, LT, LU, LY, MA, MD, ME, MG, MK, MN, MW, MX, MY, MZ, NA, NG, NI, NO, NZ, OM, PA, PE, PG, PH, PL, PT, QA, RO, RS, RU, RW, SA, SC, SD, SE, SG, SK, SL, SM, ST, SV, SY, TH, TJ, TM, TN, TR, TT, TZ, UA, UG, US, UZ, VC, VN, ZA, ZM, ZW.

(84) Designated States (*unless otherwise indicated, for every kind of regional protection available*): ARIPO (BW, GH, GM, KE, LR, LS, MW, MZ, NA, RW, SD, SL, SZ, TZ, UG, ZM, ZW), Eurasian (AM, AZ, BY, KG, KZ, RU, TJ, TM), European (AL, AT, BE, BG, CH, CY, CZ, DE, DK, EE, ES, FI, FR, GB, GR, HR, HU, IE, IS, IT, LT, LU, LV, MC, MK, MT, NL, NO, PL, PT, RO, RS, SE, SI, SK, SM, TR), OAPI (BF, BJ, CF, CG, CI, CM, GA, GN, GQ, GW, KM, ML, MR, NE, SN, TD, TG).**Declarations under Rule 4.17:**— *of inventorship (Rule 4.17(iv))***Published:**— *with international search report (Art. 21(3))*— *before the expiration of the time limit for amending the claims and to be republished in the event of receipt of amendments (Rule 48.2(h))*

(54) Title: MECHANICAL ACTUATOR APPARATUS FOR A TOUCHSCREEN

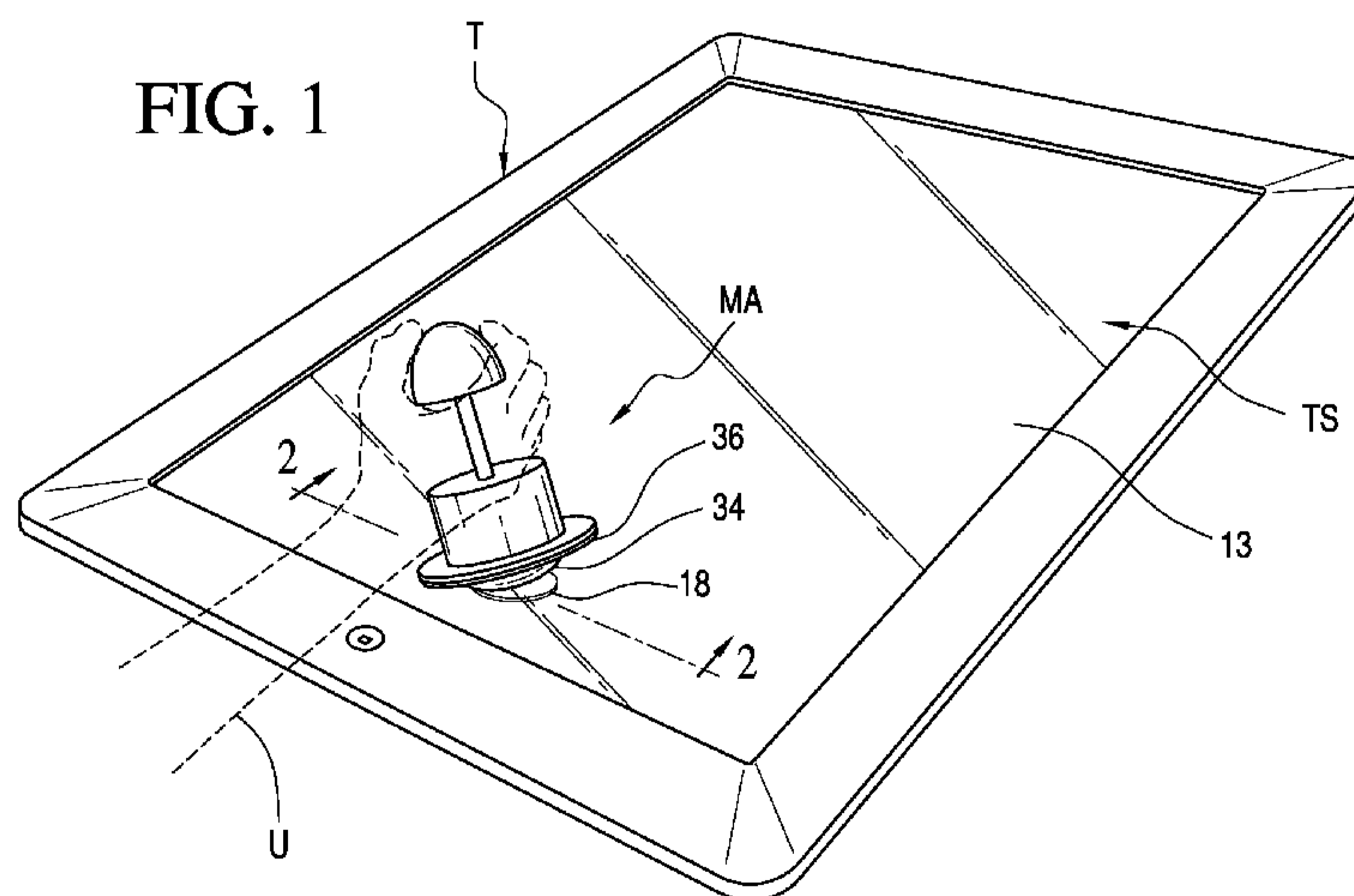

(57) Abstract: In combination with an electronic device including a touchscreen with a first user interaction surface and a second surface, a joystick apparatus includes a joystick with a handle portion and a cooperating base portion with an upstanding sleeve. The handle portion includes a skirt portion for operably engaging the sleeve to thereby secure a first magnetic member therebetween. An attachment member is positioned on the second surface of the touchscreen and includes a second magnetic member for engaging the first magnetic member. The base portion of the joystick includes a conductive member for contacting the first user interaction surface of the touchscreen.

WO 2014/137852 A1

MECHANICAL ACTUATOR APPARATUS FOR A TOUCHSCREEN

CROSS-REFERENCE TO RELATED APPLICATIONS

- 5 **[0001]** The present application claims priority on prior U.S. Application S.N. 13/789,807, filed March 8, 2013, which is hereby incorporated herein in its entirety by reference.

FIELD AND BACKGROUND OF THE INVENTION

- 10 **[0002]** The present invention is generally directed to computer or electronic input devices, and more particularly to a mechanical actuator apparatus for a touchscreen or touch sensing display having a touch sensing surface.
- 15 **[0003]** The recent explosion in the popularity of hand-held electronic devices, such as smartphones, tablet computers, etc., has brought to the forefront touch sensing displays, touchscreens, and the like. Gone are the days of bulky cellular or mobile phones and huge laptops, which included

the old-style keyboards. The modern cellular phones, for example, are known as “smartphones” that have the capability to perform many functions other than merely being a communication device. More particularly, these smartphones function as computing devices, GPS (global positioning system) devices, financial transaction devices, and perform many other functions that were previously performed by multiple individual devices. The old-style keypad or keyboard has now been replaced by a touchscreen or touch sensing display, which typically includes a touch sensing surface. The touchscreen or touch sensing display generally includes a virtual or digital onscreen keyboard in place of the old-style physical keyboard.

[0004] A touchscreen is an electronic visual display that a user can control via simple or multi-touch gestures by touching the screen with one or more fingers, a stylus, a tracer, or some other mechanical actuator, or other object, such as specially coated gloves. Various touchscreen technologies are currently available that utilize different methods of sensing touch. The examples include resistive, surface acoustic wave, capacitive, infrared grid, infrared acrylic projection, optical imaging, dispersive signal technology, acoustic pulse recognition, etc. In a typical application, the system determines the intended command based on the controls displayed on the screen and the location of the touch. “Touchscreen” *Wikipedia*, the

free encyclopedia, <http://en.wikipedia.org/wiki/Touchscreen>. Accessed February 21, 2013, 9 pp.

[0005] The smartphones, tablet computers, and the like, are also
5 now being used to play electronic games that were traditionally played on
home computers utilizing various accessories, such as joysticks, steering
wheels, game controllers, and other similar input devices. In this regard,
although a tablet or smartphone may include a virtual input device, such as
an onscreen joystick, such arrangement lacks the full experience or the feel
10 of manipulating, for example, a physical joystick. Therefore, the users, and
particularly the electronic game enthusiasts, appreciate the use of a
physical mechanical actuator, such as a joystick, in connection with an
electronic device, such as a tablet computer, smartphone, and the like.

15 **[0006]** Various electronic devices, touch sensitive screens and
displays, and input devices are disclosed in U.S. Patents/Publications Nos.
4,600,807; 6,606,081B1; 6,903,662B2; 6,950,089B1; 7,391,410B2;
7,924,145B2; 8,138,869B1; 8,143,982B1; 8,143,983B1; 8,199,114B1;
8,242,868B2; 8,310,351B2; 8,330,713B2; 2006/0007179A1;
20 2006/0256090A1; 2010/0079403A1; 2011/0199325A1; 2011/0248947A1;
2012/0169597A1; 2013/0002571A1; and Foreign/PCT patent documents

DE 102009006153; KR 10-2012-0099902; WO 2012/005463 A2; WO
2012/094198 A1, and WO 2012/139203 A1.

[0007] In view of the popularity of smartphones, tablets, and other
5 electronic devices using touchscreens, and to provide the look-and-feel of
an external input device, such as a joystick, slider, knob, directional pad, or
the like, there is a need in the industry for a mechanical actuator apparatus
that provides a user with the real look-and-feel of an actual physical
actuator, when used on a touchscreen.

10

ASPECTS AND BRIEF SUMMARY OF THE INVENTION

[0008] The present disclosure is directed to various aspects of the
present invention.

15 **[0009]** One aspect of the present invention is to provide a
mechanical actuator apparatus for a touchscreen of an electronic device.

[0010] Another aspect of the present invention is to provide a
joystick apparatus for a touchscreen of an electronic device.

20

[0011] Another aspect of the present invention is to provide a
mechanical actuator or joystick apparatus, which allows an external

actuator, such as a joystick, to be directly mounted over and engage a touch sensing surface of an electronic device. The apparatus allows a quick and easy substitution of the actuator or joystick, as needed.

5 **[0012]** Another aspect of the present invention is to provide a mechanical actuator or joystick apparatus, which allows an external actuator, such as a joystick, to be directly mounted over and engage a touch sensing surface of an electronic device. The apparatus allows a quick and easy connect or disconnect of the actuator or joystick, and
10 positioning thereof anywhere over the touch sensing surface.

[0013] Another aspect of the present invention is to provide in combination with an electronic device including a touchscreen with a first user interaction surface and a second surface, a joystick apparatus
15 including a joystick with a handle portion and a cooperating base portion with an upstanding sleeve. The handle portion includes a skirt portion for operably engaging the sleeve to thereby secure a first magnetic member therebetween. An attachment member is positioned on the second surface of the touchscreen and includes a second magnetic member for engaging
20 the first magnetic member. The base portion further includes a conductive member for contacting the first user interaction surface of the touchscreen.

[0014] Another aspect of the present invention is to provide an electronic device, which comprises a touchscreen including a first user interaction surface and a second surface, and a magnetic mesh member positioned on the second surface for cooperating with an external
5 mechanical actuator, wherein the second surface is disposed within the electronic device.

[0015] Another aspect of the present invention is to provide a method of attaching a joystick to a touchscreen of an electronic device,
10 which comprises a) providing a touchscreen with a user interaction surface and a generally opposite second surface including a magnetic mesh mounted thereto, b) providing a joystick including a magnetic member, and c) manipulating the joystick over the touchscreen so as to engage the magnetic member with the magnetic mesh.

15

[0016] Another aspect of the present invention is to provide a method of attaching a joystick to a touchscreen of an electronic device, which includes a) providing a joystick including a first magnetic member, b) providing a touchscreen, including i) a user interaction surface and a
20 generally opposite second surface, ii) the second surface including an attachment member mounted thereto, and iii) the attachment member including a second magnetic member, and c) manipulating the joystick over

the touchscreen so as to engage the first magnetic member with the second magnetic member.

[0017] In summary, the present invention provides a mechanical actuator apparatus that can be easily used with the touchscreen of an electronic device, such as a tablet, cellular phone, fablet, phablet, etc., and which allows the user with the real look-and-feel of an external input device, such as a joystick. The actuator apparatus further provides the flexibility of easily switching between external input devices, as desired.

10

BRIEF DESCRIPTION OF THE DRAWINGS

[0018] One of the above and other aspects, novel features and advantages of the present invention will become apparent from the following detailed description of a preferred embodiment(s) of the invention, as illustrated in the drawings, in which:

15

[0019] Figure 1 is a perspective view of a preferred embodiment of a mechanical actuator apparatus of the present invention, shown in use in conjunction with a tablet;

20

[0020] Figure 2 is an enlarged cross-sectional view taken along line 2-2 of Figure 1;

[0021] Figure 3 is a partial exploded view of the mechanical actuator shown in Figure 1;

[0022] Figure 4 is a view similar to Figure 3, showing an alternate preferred embodiment of the mechanical actuator apparatus of the present invention;

[0023] Figure 5 is an enlarged view similar to Figure 2, shown without the mechanical actuator (joystick); and

10

[0024] Figure 6 is a view similar to Figure 5, showing the alternate embodiment of Figure 4.

15 DETAILED DESCRIPTION OF THE PREFERRED EMBODIMENT(S)
OF THE INVENTION

[0025] As best shown in Figures 1-3, the mechanical actuator apparatus MA, in accordance with a preferred embodiment of the invention, includes a joystick 10, and an attachment member 12, both configured and constructed to function in operative engagement with each other. In particular, the attachment member 12 is mounted on the underside 11 of the touchscreen TS of a tablet T (Figure 3), by using a suitable adhesive, or electrostatic, electromagnetic, or magnetostatic charge, or other suitable technique. In this regard, one would appreciate that in an assembled

electronic device, the underside 11 would face the interior thereof, while the opposite user interaction surface 13 would be external to the electronic device and face the user U.

5 [0026] The attachment member 12, preferably includes top and bottom clear films 14 and 16, sandwiching therebetween a magnetic member 18 of a suitable size and shape at a preferred location. In particular, the films 14 and 16 are preferably held together by an adhesive, or electrostatic, electromagnetic, or magnetostatic charge, or some other
10 suitable means. The films 14 and 16 are preferably made of a flexible, yet durable polyethylene or the like material having a thickness in the range of about 0.2 mm to 4 mm, or an alternative range to suit the needs of a manufacturer of the touchscreen and/or the applicable electronic device.

15 [0027] The size of the attachment member 12 is selected to preferably correspond to the size of the touchscreen underside 11. It is noted, however, that it is within the scope of the present invention to vary the overall size of the attachment member 12 to be smaller or larger than the size of the touchscreen TS.

20

[0028] It is also noted herewith that it is within the scope of the present invention to use only one film, instead of two, as illustrated.

[0029] Referring to Figure 2, the preferred structural details of the joystick 10 will now be described. As shown, the joystick 10 includes an upper handle portion 22, and a cooperating lower base portion 24. The handle portion 22 includes a skirt 26 that engages with an upstanding sleeve 28 of the base portion 24. The skirt 26 and sleeve 28, together define therebetween a recess 30 for accommodating a magnetic member 32 of a suitable size and shape. It is noted herewith that the inter-fitting construction and arrangement of the skirt 26 and sleeve 28 may be varied or reversed, if needed. For instance, in an alternate arrangement, the skirt 26 would fit inside the sleeve 28, instead of sliding over, as shown in Figure 2.

[0030] The joystick 10 further includes a non-conductive pad 34 or the like member positioned preferably centrally on the base portion 24. The thickness of the non-conductive member 34 is selected to keep the bottom surface 25 of the base portion 24 a preferred distance (0.5 mm – 3 mm) from the user interaction surface 13, thereby allowing a user to manipulate or rock the joystick 10, during use. In this regard, a continuous (or segmented) strip of conductive pad 36 or the like is provided along the periphery on the bottom surface 25 of the base portion 24. Alternatively, the conductive pad 36 may cover the entire bottom surface 25. The conductive pad 36 is preferably made of a material including silicone resin,

vinyl chloride resin, siloxane resin, and/or a polyolefin resin, doped with a
conductive metal or filler. Preferably, the height of the joystick 10 is 30-60
mm. One skilled in the art would readily appreciate that by manipulating
the joystick 10, a user U can easily make a contact with the user interaction
5 surface 13, as desired (Figures 1 and 2).

[0031] From the above description, and as illustrated in Figures 1-3
and 5, it would be readily appreciated that by mounting the attachment
member 12 on the underside 11 of the touchscreen TS, and manipulating
10 the joystick 10 over the magnetic member 18, the joystick 10 can be held
thereover due to the magnetic force between the magnetic members 18
and 32. In this regard, it is noted herewith that the term "magnetic
member" as used herein, includes, but not limited to, a permanent magnet
or electromagnet, and a member that is attractable to or by a magnet.

15

[0032] Figures 4 and 6 illustrate an alternate preferred embodiment
of the mechanical actuator apparatus MAA of the present invention, which
is similar to the embodiment described above, with the exception that the
magnetic member 18 is substituted by a magnetic mesh 38 of a suitable
20 thickness and design, and preferably corresponding in size to the bottom
film 16 and the touchscreen underside 11. It is noted herewith that only a
single film 16 is preferably used in the alternate embodiment.

[0033] The magnetic mesh 38 is secured between the bottom film 16 and the underside 13 of the touchscreen TS, preferably by using an adhesive, or other means, such as electrostatic, magnetostatic, electromagnetic, etc., force. It is noted herewith that the magnetic mesh 38
5 may alternatively be mounted directly to the touchscreen underside 11 in the same manner, without using the film 16.

[0034] One would readily appreciate the advantage of providing the magnetic mesh 38 on the underside 11 of the touchscreen, in that a user
10 can position the joystick 10 anywhere on the touchscreen TS, by simply detaching the joystick 10 from one position and re-positioning at another location, using the magnetic force between the magnetic member 32 and the magnetic mesh 38.

[0035] It is noted herewith that while the present invention is
15 described and illustrated in conjunction with a tablet, it can be used with any electronic device, including, but not limited to, a television, videogame monitor, videogame console, a gaming device, a desktop computer, a laptop computer, a personal digital assistant (PDA), a fablet, a phablet, a
20 cellphone, a mobile phone, a smartphone, or a combination thereof.

[0036] While this invention has been described as having preferred sequences, ranges, steps, order of steps, materials, structures, symbols, indicia, graphics, color scheme(s), shapes, configurations, features, components, or designs, it is understood that it is capable of further
5 modifications, uses and/or adaptations of the invention following in general the principle of the invention, and including such departures from the present disclosure as those come within the known or customary practice in the art to which the invention pertains, and as may be applied to the central features hereinbefore set forth, and fall within the scope of the
10 invention and of the limits of the claims appended hereto or presented later. The invention, therefore, is not limited to the preferred embodiment(s) shown/described herein.

REFERENCES

15 **[0037]** The following reference, and any cited in the disclosure herein, are hereby incorporated herein in their entirety by reference.

1. "Touchscreen" *Wikipedia*, the free encyclopedia, <http://en.wikipedia.org/wiki/Touchscreen>. Accessed February 21, 2013, 9 pp.

20

WHAT IS CLAIMED IS:

1. In combination with an electronic device including a touchscreen with a first user interaction surface and a second surface, a joystick apparatus, comprising:
- 5
- a) a joystick including a handle portion and a cooperating base portion;
 - b) said base portion including an upstanding sleeve;
 - c) said handle portion including a skirt portion for operably engaging said sleeve for thereby securing a first magnetic member therebetween;
 - 10
 - d) an attachment member positioned on the second surface of the touchscreen and including a second magnetic member for engaging said first magnetic member;
 - 15
 - e) said base portion including a conductive member for contacting the first user interaction surface of the touchscreen.
- 20
2. The joystick apparatus of Claim 1, wherein:
- a) said second magnetic member is immovably positioned relative to said attachment member.

3. The joystick apparatus of Claim 1, wherein:
- a) said attachment member comprises a film having said second magnetic member embedded therein.
- 5 4. The joystick apparatus of Claim 1, wherein:
- a) said attachment member comprises two films sandwiching said second magnetic member therebetween.
- 10 5. The joystick apparatus of Claim 2, wherein:
- a) said attachment member is immovably positioned on the second surface.
6. The joystick apparatus of Claim 5, wherein:
- 15 a) said second magnetic member is positioned anywhere within the boundaries of said attachment member.
7. The joystick apparatus of Claim 5, wherein:
- a) said attachment member is made of a clear film substantially corresponding in size to the second surface.
- 20

8. The joystick apparatus of Claim 1, wherein:
- a) said second magnetic member is immovably positioned relative to the second surface and at a location corresponding to a predetermined position for said first magnetic member.
- 5
9. The joystick apparatus of Claim 8, wherein:
- a) the predetermined position for said first said first magnetic member lies anywhere on the touchscreen.
- 10
10. The joystick apparatus of Claim 9, wherein:
- a) said second magnetic member is smaller or larger in size than the second surface.
- 15
11. The joystick apparatus of Claim 2, wherein:
- a) said second magnetic member is positioned anywhere within the boundaries of the touchscreen.
12. The joystick apparatus of Claim 5, wherein:
- a) said second magnetic member comprises a magnetic mesh.
- 20

13. The joystick apparatus of Claim 12, wherein:
- a) said magnetic mesh corresponds in size to the first user interaction surface.
- 5 14. The joystick apparatus of Claim 12, wherein:
- a) said magnetic mesh is smaller or larger in size than the first user interaction surface.
- 10 15. The joystick apparatus of Claim 1, wherein:
- a) said upstanding sleeve defines a recess therein for holding said first magnetic member.
- 15 16. The joystick apparatus of Claim 1, wherein:
- a) said skirt portion defines a recess therein for holding said first magnetic member.
17. The joystick apparatus of Claim 1, wherein:
- a) the second surface is generally opposite to the first user interaction surface.

20

18. The joystick apparatus of Claim 1, wherein:
- a) the second surface is disposed within the electronic device.
- 5 19. The joystick apparatus of Claim 1, wherein:
- a) the electronic device comprises a television, videogame monitor, videogame console, a gaming device, a desktop computer, a laptop computer, a tablet, a personal digital assistant (PDA), a fablet, a phablet, a cellphone, a mobile phone, a smartphone, or a combination thereof.
- 10
20. An electronic device, comprising:
- a) a touchscreen including a first user interaction surface and a second surface;
- 15 b) a magnetic mesh member positioned on said second surface for cooperating with an external mechanical actuator; and
- c) said second surface being disposed within the electronic device.
- 20

21. The electronic device of Claim 20, wherein:
- a) said magnetic mesh generally corresponds in size to said first user interaction surface.
- 5 22. The electronic device of Claim 20, wherein:
- a) said magnetic mesh is smaller or larger in size than said first user interaction surface.
23. The electronic device of Claim 22, wherein:
- 10 a) said magnetic mesh is positioned anywhere relative to said first user interaction surface.
24. The electronic device of Claim 23, wherein:
- a) said magnetic mesh is immovably positioned at a location corresponding to a predetermined position for the external mechanical actuator.
- 15 25. The electronic device of Claim 24 wherein:
- a) the predetermined position for the external mechanical actuator lies anywhere on the touchscreen.
- 20

26. The electronic device of Claim 25, wherein:
- a) the mechanical actuator comprises a joystick.
27. The electronic device of Claim 26, wherein:
- 5 a) the joystick comprises a handle portion and a cooperating base portion;
- b) said base portion includes an upstanding sleeve; and
- c) said handle portion includes a skirt portion for operably engaging the sleeve for thereby securing a magnetic member therebetween.
- 10
28. The electronic device of Claim 27, wherein:
- a) said base portion defines a recess therein for holding said magnetic member.
- 15
29. The electronic device of Claim 27, wherein:
- a) said skirt portion defines a recess therein for holding said magnetic member.
- 20
30. The joystick apparatus of Claim 20, wherein:
- a) the electronic device comprises a television, videogame monitor, videogame console, a gaming

device, a desktop computer, a laptop computer, a tablet, a personal digital assistant (PDA), a fablet, a phablet, a cellphone, a mobile phone, a smartphone, or a combination thereof.

5

31. A method of attaching a joystick to a touchscreen of an electronic device, comprising the steps of:

10

- a) providing a touchscreen with a user interaction surface and a generally opposite second surface, the second surface including a magnetic mesh mounted thereto;
- b) providing a joystick including a magnetic member; and
- c) manipulating the joystick over the touchscreen so as to engage the magnetic member with the magnetic mesh.

15

32. The method of Claim 31, wherein:

the second surface is disposed within the electronic device.

20

33. The method of Claim 32, wherein:

the magnetic mesh corresponds in size to the user interaction surface.

34. The method of Claim 32, wherein:

the magnetic mesh is smaller or larger in size than the user interaction surface.

5 35. The method of Claim 32, wherein:

i) the joystick includes a handle portion and a cooperating base portion;

ii) the base portion includes an upstanding sleeve; and

10 iii) the handle portion includes a skirt portion for operably engaging the sleeve for thereby securing the magnetic member therebetween.

36. The method of Claim 35, wherein:

15 the base portion defines a recess therein for holding the magnetic member.

37. The method of Claim 35, wherein:

20 the skirt portion defines a recess therein for holding the magnetic member.

38. A method of attaching a joystick to a touchscreen of an electronic device, comprising the steps of:
- a) providing a joystick including a first magnetic member;
 - b) providing a touchscreen, comprising:
 - 5 i) a user interaction surface and a generally opposite second surface;
 - ii) the second surface including an attachment member mounted thereto; and
 - iii) the attachment member including a second
10 magnetic member;
 - c) manipulating the joystick over the touchscreen so as to engage the first magnetic member with the second magnetic member.
- 15 39. The method of Claim 38, wherein:
the second surface is disposed within the electronic device.
40. The method of Claim 39, wherein:
20 the second magnetic member is immovably positioned relative to the attachment member.

41. The method of Claim 39, wherein:

the attachment member is made of a clear film.

42. The method of Claim 39, wherein:

5

i) the joystick includes a handle portion and a cooperating base portion;

ii) the base portion includes an upstanding sleeve; and

iii) the handle portion includes a skirt portion for operably engaging the sleeve for thereby securing the magnetic

10

member therebetween.

43. The method of Claim 42, wherein:

the base portion defines a recess therein for holding the first magnetic member.

15

44. The method of Claim 42, wherein:

the skirt portion defines a recess therein for holding the first magnetic member.

2/3

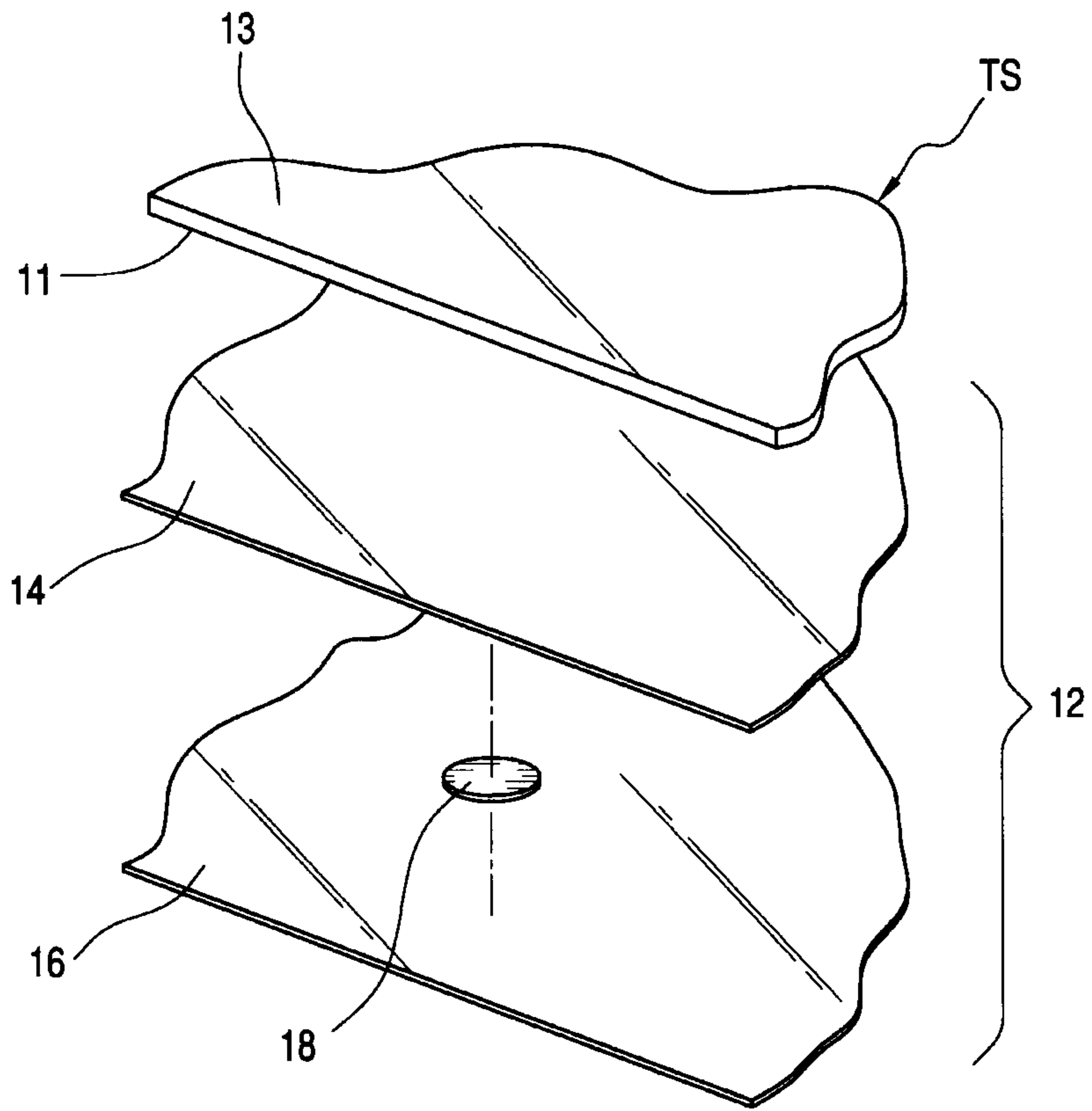

FIG. 3

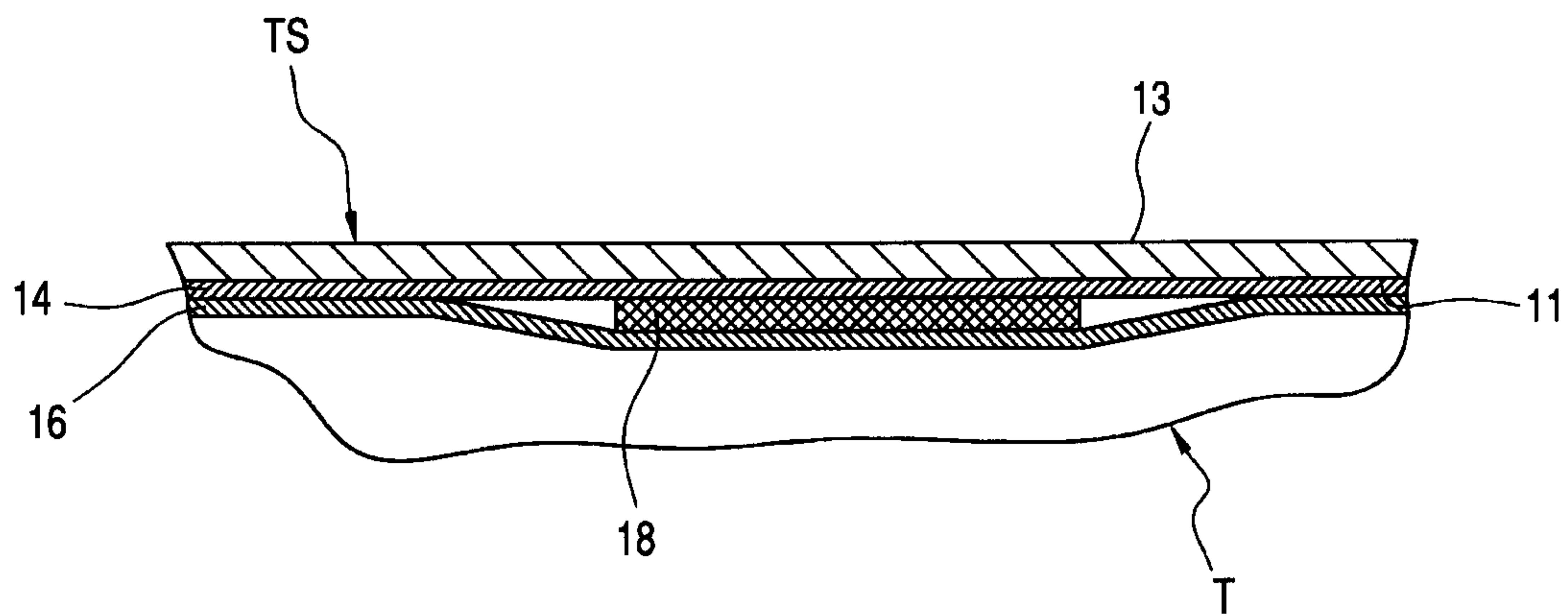

FIG. 5

3/3

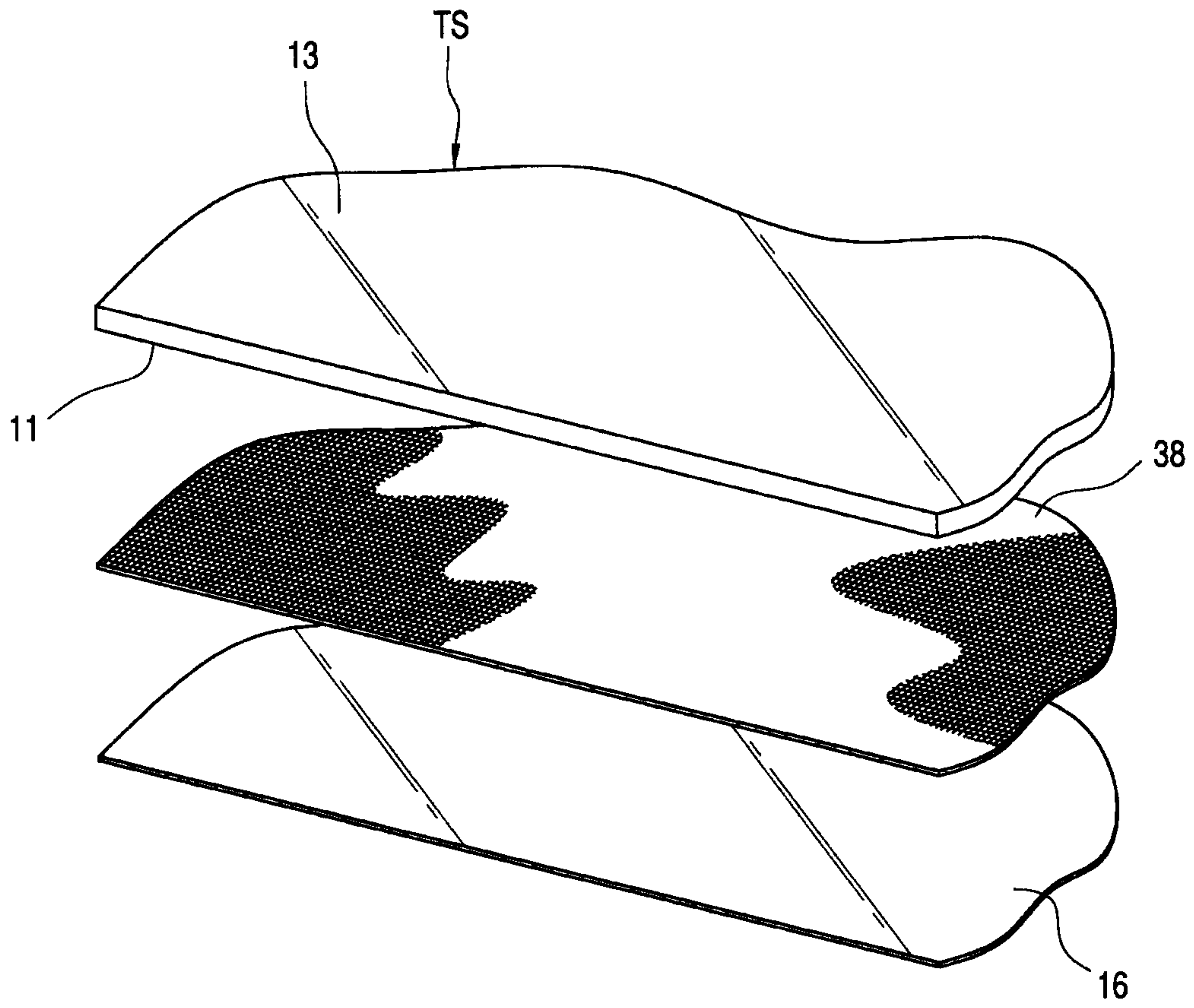

FIG. 4

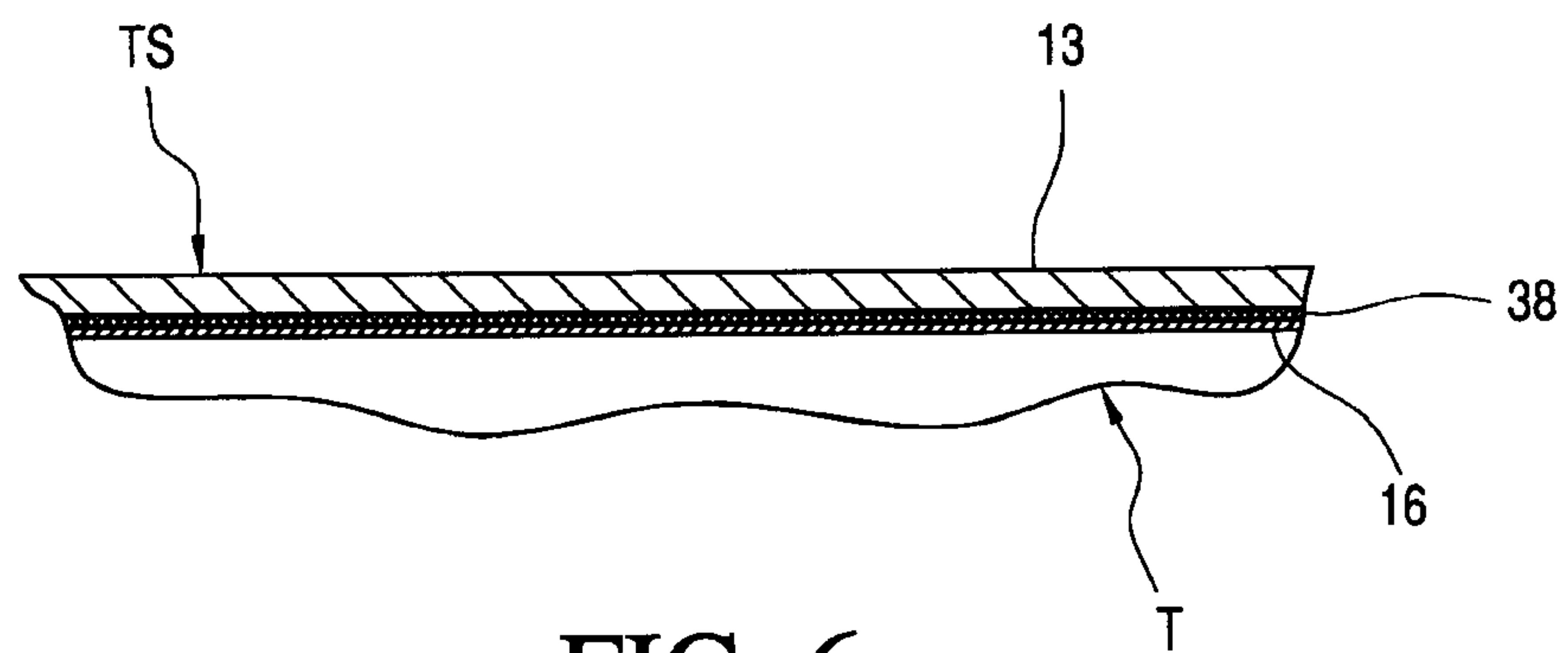

FIG. 6

FIG. 1

