



- (51) **International Patent Classification:**
H04M 1/02 (2006.01)
- (21) **International Application Number:**
PCT/CN2017/095559
- (22) **International Filing Date:**
02 August 2017 (02.08.2017)
- (25) **Filing Language:** English
- (26) **Publication Language:** English
- (30) **Priority Data:**
201620854528.X 08 August 2016 (08.08.2016) CN
201610643272.2 08 August 2016 (08.08.2016) CN
- (71) **Applicant:** **GUANGDONG OPPO MOBILE TELECOMMUNICATIONS CORP., LTD.** [CN/CN]; No.18, Haibin Road, Wusha, Chang'an, Dongguan, Guangdong 523860 (CN).
- (72) **Inventors:** **LI, Jing**; No.18, Haibin Road, Wusha, Chang'an, Dongguan, Guangdong 523860 (CN). **YANG, Guangming**; No.18, Haibin Road, Wusha, Chang'an, Dongguan, Guangdong 523860 (CN). **GONG, Qingguo**; No.18, Haibin Road, Wusha, Chang'an, Dongguan, Guangdong 523860 (CN).
- (74) **Agent:** **SCIHEAD IP LAW FIRM**; Room 1508, Huihua Commercial & Trade Building, No. 80, XianLie Zhong Road, Yuexiu District, Guangzhou, Guangdong 510070 (CN).
- (81) **Designated States** (*unless otherwise indicated, for every kind of national protection available*): AE, AG, AL, AM, AO, AT, AU, AZ, BA, BB, BG, BH, BN, BR, BW, BY, BZ, CA, CH, CL, CN, CO, CR, CU, CZ, DE, DJ, DK, DM, DO, DZ, EC, EE, EG, ES, FI, GB, GD, GE, GH, GM, GT, HN,

HR, HU, ID, IL, IN, IR, IS, JO, JP, KE, KG, KH, KN, KP, KR, KW, KZ, LA, LC, LK, LR, LS, LU, LY, MA, MD, ME, MG, MK, MN, MW, MX, MY, MZ, NA, NG, NI, NO, NZ, OM, PA, PE, PG, PH, PL, PT, QA, RO, RS, RU, RW, SA, SC, SD, SE, SG, SK, SL, SM, ST, SV, SY, TH, TJ, TM, TN, TR, TT, TZ, UA, UG, US, UZ, VC, VN, ZA, ZM, ZW.

- (84) **Designated States** (*unless otherwise indicated, for every kind of regional protection available*): ARIPO (BW, GH, GM, KE, LR, LS, MW, MZ, NA, RW, SD, SL, ST, SZ, TZ, UG, ZM, ZW), Eurasian (AM, AZ, BY, KG, KZ, RU, TJ, TM), European (AL, AT, BE, BG, CH, CY, CZ, DE, DK, EE, ES, FI, FR, GB, GR, HR, HU, IE, IS, IT, LT, LU, LV, MC, MK, MT, NL, NO, PL, PT, RO, RS, SE, SI, SK, SM, TR), OAPI (BF, BJ, CF, CG, CI, CM, GA, GN, GQ, GW, KM, ML, MR, NE, SN, TD, TG).

Published:

— with international search report (Art. 21(3))

- (54) **Title:** HOUSING, METHOD FOR MANUFACTURING HOUSING, AND MOBILE TERMINAL HAVING HOUSING

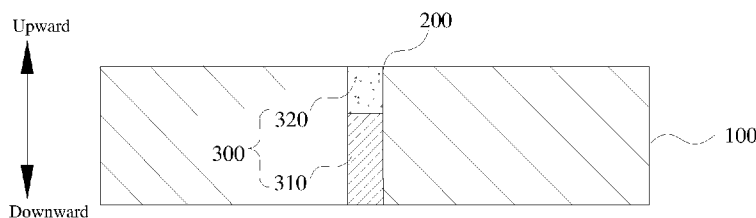

Fig. 3

- (57) **Abstract:** A housing for a mobile terminal, a method for manufacturing the housing, and a mobile terminal having the housing are provided. The housing includes a substrate made of metal, at least one slot penetrating through the substrate in a thickness direction of the substrate, and a filling layer received in the at least one slot. The filling layer includes an insulating sub-layer and a printed sub-layer located on the insulating sub-layer.



HOUSING, METHOD FOR MANUFACTURING HOUSING, AND MOBILE TERMINAL HAVING HOUSING

TECHNICAL FIELD

The present disclosure relates to electronic devices, and more particularly, to a housing for a mobile terminal, a method for manufacturing the housing, and a mobile terminal having the housing.

BACKGROUND

For the purpose of beautiful appearance and size reduction, a mobile terminal, such as a mobile phone, currently has a built-in antenna configured to transmit and receive signals. The built-in antenna requires that the mobile phone should have a housing not blocking signal transmission and reception. However, metal housings instead of plastic housings are gradually applied to mobile terminals such as mobile phones, since the metal housings have more beautiful appearances, abrasion resistance, and scratch resistance. In this case, in order to enable signal transmission and reception, a slot should be formed in the metal housing of the mobile terminal and filled with insulating material such as plastic, but the insulating material received in the slot has a color quite different from the anodized surface of the metal, which seriously destroys the unity of the housing.

SUMMARY

The present disclosure is intended to provide a housing, a method for manufacturing the housing, and a mobile terminal.

In one aspect of the present disclosure, a housing is provided. The housing includes a substrate, made of metal; at least one slot, penetrating through the substrate in a thickness direction of the substrate; and a filling layer, received in the at least one slot, and comprising an insulating sub-layer and a printed sub-layer located on the insulating sub-layer.

According to the present disclosure, the printed sub-layer is disposed in the housing, and by adjusting the color of the printed sub-layer, the color of the printed sub-layer can be effectively and conveniently rendered substantially the same as that of the outer surface of the substrate, thereby obviously reducing the color difference between the slot and the substrate, and significantly improving the unity of the mobile terminal.

In another aspect of the present disclosure, a method for manufacturing a housing is provided. The method includes forming at least one slot in a substrate made of metal and filling the at least one slot with insulating material, the at least one slot penetrating through the substrate in a thickness direction of the substrate; forming an insulating sub-layer by removing an upper part of the insulating material; and disposing a printed sub-layer on the insulating sub-layer.

According to the present disclosure, by means of the method, the printed sub-layer covering the insulating sub-layer can be formed in the slot, and by adjusting the color of the printed sub-layer, the color of the printed sub-layer can be effectively and conveniently rendered substantially the same as that of the outer surface of the substrate, thereby obviously reducing the color difference between the slot and the substrate, and significantly improving the unity of the mobile terminal.

In yet another aspect of the present disclosure, a mobile terminal is provided. The

mobile terminal includes the foregoing housing and an antenna. The at least one slot is aligned with the antenna

According to the present disclosure, the mobile terminal has a beautiful appearance, abrasion resistance, and the housing of the mobile terminal has the slot having substantially the same appearance as the metal substrate.

BRIEF DESCRIPTION OF THE DRAWINGS

Fig. 1 is a schematic structural diagram of a mobile terminal according to an implementation of the present disclosure.

Fig. 2 is a schematic structural diagram of a mobile terminal according to another implementation of the present disclosure.

Fig. 3 is a schematic structural diagram of a housing according to an implementation of the present disclosure.

Fig. 4 is a schematic structural diagram of a housing according to another implementation of the present disclosure.

Fig. 5 is a schematic structural diagram of a housing according to yet another implementation of the present disclosure.

Fig. 6 is a flowchart of manufacturing a housing of a mobile terminal according to an implementation of the present disclosure.

DETAILED DESCRIPTION

The implementations of the present disclosure will be described in detail hereinafter. The implementations described below are exemplary and merely illustrative of the present disclosure, and are not to be construed as a limit to the present disclosure. Methods without specific technologies or conditions in the

implementations are performed according to technologies or conditions described in documents in the art, or according to product specifications. Reagents or instruments of which manufacturers are not indicated are commercially available conventional ones.

According to one aspect of the present disclosure, a housing for a mobile terminal is provided. Fig. 3 is a schematic structural diagram of a housing according to an implementation of the present disclosure. As illustrated in Fig. 3, the housing includes a substrate 100, a slot 200, and a filling layer 3.

In one implementation of the present disclosure, the substrate 100 is made of metal. The metal used for forming the substrate 100 is not particularly limited, and may be any metal known in the art capable of being used for forming the housing of the mobile terminal, for example, the metal includes, but is not limited to, aluminum alloy and the like. The substrate 100 also has a shape not particularly limited and may be flexibly shaped by persons skilled in the art, as long as the substrate 100 can be mated with other members constituting the mobile terminal. In one implementation of the present disclosure, in order to improve surface hardness and abrasion resistance of the substrate 100, expand application scope thereof, and prolong service life thereof, the substrate 100 may be anodized. As illustrated in Fig. 5, an anodized layer 110 is formed on the outer surface (upper surface in Fig. 5) of the substrate 100.

In one implementation of the present disclosure, the slot 200 penetrates through the substrate 100 in the thickness direction (the vertical direction in Figs. 3 to 5) thereof, and is filled with the filling layer 300. The filling layer 300 includes an insulating sub-layer 310 and a printed sub-layer 320 located on the insulating sub-layer 310. In one implementation of the present disclosure, position, shape,

number, etc., of the slot(s) 200 are not particularly limited, and any slot known in the art formed for the antenna is applicable here, as long as signals can be transmitted and received. The position, shape, number, etc., of the slot(s) 200 as illustrated in Figs. 3 to 5 are exemplary and are not to be construed as a limit to the present disclosure. Figs. 3 to 5 are schematic cross-sectional views of different structures of the slot 200 taken along an A-A' direction in Figs. 1 and 2, while for purpose of convenience, only one slot 200 is illustrated in Figs. 3 to 5. Actually, in one implementation of the present disclosure, the position, shape, number, etc., of the slot(s) 200 may be as illustrated in Fig. 1 or Fig. 2, as long as the position of the slot 200 is aligned with the position of the built-in antenna in the mobile terminal, to enable signal transmission and reception.

In one implementation of the present disclosure, the filling layer 300 is received in the slot 200, and includes an insulating sub-layer 310 and a printed sub-layer 320 located on the insulating sub-layer 310.

In one implementation of the present disclosure, the material used for forming the insulating sub-layer 310 is not particularly limited, and may be any insulating material known in the art, and may be flexibly customized by persons skilled in the art. In one implementation of the present disclosure, the insulating material may include, but is not limited to, polyphenylene sulfite (PPS), polybutylene terephthalate (PBT), and the like.

In one implementation of the present disclosure, the printed sub-layer 320 is located on the insulating sub-layer 310, and covers the insulating sub-layer 310. Thus, by means of rendering the color of the printed sub-layer 320 substantially the same as that of the outer surface of the substrate 100, the color difference between the slot 200

and the outer surface of the substrate 100 can be reduced conveniently and effectively, thereby improving the unity of the mobile terminal.

Generally, the slot 200 has a small size, and the thickness of the insulating sub-layer 310 may not be precisely controlled in a process of injecting insulating material to form the insulating sub-layer 310. In this case, in one implementation of the present disclosure, when manufacturing the housing, firstly, the slot 200 may be filled with the insulating material used for forming the insulating sub-layer 310; secondly, the insulating material received in the slot 200 is cut with processes including, but not limited to, a Computer Numerical Control (CNC) machining, and the upper part of the insulating material (adjacent to the outer surface of the substrate 100) is removed so as to form the insulating sub-layer 310 in the lower part of the slot 200 and a groove in the upper part of the slot 200; thirdly, the groove is filled with the printed sub-layer 320. The groove has the same width as the insulating sub-layer 310, and thus the printed sub-layer 320 received in the groove also has the same width as the insulating sub-layer 310, as illustrated in Fig. 3.

In one implementation of the present disclosure, when the upper part of the insulating material is removed, the metal adjacent to the upper part of the insulating material in the width direction (the vertical direction in Figs. 1 to 2 and the horizontal direction in Figs. 3 to 5) of the slot 200 may also be removed, and consequently, a groove having a width larger than the insulating sub-layer 310 is formed in the upper part of the slot 200. Thus, the printed sub-layer 320 received in the groove also has a width larger than the insulating sub-layer 310 in the lower part of the slot 200, as illustrated in Fig. 4, thereby ensuring that the printed sub-layer 320 fully covers the insulating sub-layer 310, and avoiding the exposure of a part of the insulating

sub-layer 310 which affects the unity of the mobile terminal. The exposure of a part of the insulating sub-layer 310 may be due to operation errors arising when the printed sub-layer 320 is disposed. In one implementation of the present disclosure, the width of the printed sub-layer 320 is 0.02-0.06mm larger than the width of the insulating sub-layer 310.

In one implementation of the present disclosure, when the width of the printed sub-layer 320 is larger than that of the insulating sub-layer 310, the center of the printed sub-layer 320 may be aligned with the center of the insulating sub-layer 310 in the thickness direction of the substrate 100, or may be misaligned to some extent, as long as the printed sub-layer 320 can fully cover the insulating sub-layer 310.

In one implementation of the present disclosure, the printed sub-layer 320 may have a thickness of 0.1-0.3mm which is appropriate since the color of the printed sub-layer 320 may be affected if the thickness thereof is less than 0.1mm while some of the material of the printed sub-layer 320 may be unnecessary if the thickness thereof is larger than 0.3mm.

In one implementation of the present disclosure, the material used for forming the printed sub-layer 320 and the way of disposing the printed sub-layer 320 are not particularly limited. In one implementation of the present disclosure, the printed sub-layer 320 may be formed of a polymer film subjected to a printing process and is fixed on the insulating sub-layer 310 by adhesive. The polymer forming the polymer film is also not particularly limited, and may be any polymer the color of which can be changed by printing, and may be flexibly customized by persons skilled in the art. For example, in one implementation of the present disclosure, the polymer film may be formed from at least one selected from a group consisting of polyethylene

terephthalate (PET), polymethyl methacrylate (PMMA), and polycarbonate (PC). For example, in one implementation of the present disclosure, the polymer film may be formed from PET, or may be formed from composite material consisting of PMMA and PC. The polymer film formed from the above-mentioned polymer has a fine printing effect, thereby further improving the uniformity between the outer surface of the polymer film in the slot 200 and the metal substrate 100.

Furthermore, in one implementation of the present disclosure, the polymer film has a structure not particularly limited. For example, in one implementation of the present disclosure, the transparent polymer film formed of PET may have a high gloss surface and a matte surface. The high gloss surface has been subjected to the printing process, and is in contact with the insulating sub-layer 310, while the matte surface is exposed outside. In order to facilitate mass manufacture, firstly, the film is manufactured with the above-mentioned polymer, and cut to size suitable for printing, and then the color of the film is rendered the same as the substrate 100 by printing, for example, the color may be gold, pale pink, silver, or the like. After that, the polymer film with a printed color is punched to form one or more printed sub-layers 320 having a size suitable for being received in the groove. The adhesive formed from, for example, polyurethane or the like is disposed on the insulating sub-layer 310, and the printed sub-layer 320 having the suitable size is attached and fixed in the groove.

It should be noted that, in the present disclosure, "same", "color is the same", "same color", and the like should be broadly understood, that is to say, these expressions not only mean that the printed sub-layer 320 has exactly the same color as the substrate 100, but also mean that the printed sub-layer 320 and the substrate 100 have no obvious difference in their colors. In the present disclosure, the

above-mentioned expressions indicate that the color of the printed sub-layer 320 subjected to the printing process is close to the color of the metal substrate. Compared with conventional insulating material received in the slot 200 and not subjected to the printing process, the printed sub-layer 320 and the substrate 100 have no obvious difference in their colors when observed by human eyes.

It should be noted that, in the present disclosure, the conditions of the printing process to which the polymer film forming the printed sub-layer 320 is subjected are not particularly limited, and may be customized by those skilled in the art according to the type of the polymer and the color of the anodized outer surface of the substrate 100. For example, in one implementation of the present disclosure, firstly, a black color may be printed on the polymer film, and then the polymer film may be subjected to one or more black/white color printing processes, thereby rendering the printed color of the initially transparent polymer film more obvious.

In one implementation of the present disclosure, in order to further improve the abrasion resistance of the surface of the printed sub-layer 320 formed of the polymer film, a protective paint layer may be disposed on the polymer film.

According to the present disclosure, the printed sub-layer 320 is disposed in the housing, and by adjusting the color of the printed sub-layer 320, the color of the printed sub-layer 320 can be effectively and conveniently rendered substantially the same as that of the outer surface of the substrate 100, thereby obviously reducing the color difference between the slot 200 and the substrate 100, and significantly improving the unity of the mobile terminal.

According to another aspect of the present disclosure, a method for manufacturing a housing is provided. Fig. 6 is a flowchart of manufacturing a housing

of a mobile terminal in one implementation of the present disclosure. Referring to Fig. 6, the method is described below.

(a) A substrate used for the housing is manufactured.

In one implementation of the present disclosure, a slot 200 is formed in a substrate 100, and the slot 200 penetrates through the substrate 100 in the thickness direction (the vertical direction in Fig. 6) of the substrate 100, and is filled with insulating material.

In one implementation of the present disclosure, the substrate 100 is made of metal. The metal used for forming the substrate 100 is not particularly limited, and may be any metal known in the art capable of being used for forming the housing of the mobile terminal, for example, the metal includes, but is not limited to, aluminum alloy and the like. The substrate 100 also has a shape not particularly limited and may be flexibly shaped by persons skilled in the art, as long as the substrate 100 can be mated with other members constituting the mobile terminal. In one implementation of the present disclosure, in order to improve surface hardness and abrasion resistance of the substrate 100, expand application scope thereof, and prolong service life thereof, the substrate 100 may be anodized, and consequently, an anodized layer 110 is formed on the outer surface of the substrate 100 before the slot 200 is formed.

In one implementation of the present disclosure, the processes for manufacturing the substrate 100 used for the housing is not particularly limited, and any processes known in the art which is capable of manufacturing the substrate 100 may be adopted. In one implementation of the present disclosure, a process for manufacturing the substrate 100 used for the housing includes, but is not limited to, conventionally molding the substrate 1, forming the slot 200 penetrating through the substrate 100 by

etching, lasing, CNC machining, or the like, and filling the slot 200 with the insulating material by injection molding (e.g., Nano Molding Technology (NMT)) or the like. After the slot 200 is formed, the substrate 100 may be further polished, sandblasted, and anodized.

(b) An insulating sub-layer is formed.

In one implementation of the present disclosure, the insulating material is cut with a CNC machining, and the upper part of the insulating material (adjacent to the outer surface of the substrate 100) is removed. Consequently, the remaining insulating material forms an insulating sub-layer 310 in the lower part of the slot 200 and a groove is formed in the upper part of the slot 200. The insulating sub-layer 310 has the same width as the slot 200, and the groove has the same width as the insulating sub-layer 310.

In one implementation of the present disclosure, when the upper part of the insulating material is removed, the metal adjacent to the upper part of the insulating material in the width direction (the horizontal direction in Fig. 6) of the slot 200 may also be removed, and consequently, a groove having a width larger than the insulating sub-layer 310 is formed on the insulating sub-layer 310.

Generally, the slot 200 has a small size, and the thickness of the insulating material may not be precisely controlled in a process of injecting insulating material into the slot 200. Hence, the difficulty of manufacturing the housing is greatly increased when firstly the insulating sub-layer 310 having a thickness smaller than the depth of the slot 200 is injected in the slot 200 and then the polymer on which the color is easy to print is disposed on the insulating sub-layer 310 in the slot 200. Compared with it, the difficulty is greatly reduced when firstly the slot 200 is filled

with the insulating material and then the upper part of the insulating material as well as the metal adjacent to it is removed to form the groove. Thus, not only the width of the groove can be flexibly controlled, but also the insulating material overflowing from the slot 200 can be removed. In one implementation of the present disclosure, the processes for forming the groove are not particularly limited, and may be flexibly customized by persons skilled in the art. In one implementation of the present disclosure, the processes for forming the groove includes, but are not limited to, a CNC machining which enables simple and convenient operation, has high efficiency, a high yield, a low cost, and is suitable for mass manufacture.

In one implementation of the present disclosure, when the width of the groove is larger than that of the slot 200, the center of the groove may be aligned with the center of the slot 200 in the thickness direction of the substrate 100, thereby ensuring that a printed sub-layer 320 received in the groove fully covers the insulating sub-layer 310, and avoiding the exposure of a part of the insulating sub-layer 310 which affects the unity of the mobile terminal.

(c) A printed sub-layer is disposed.

In one implementation of the present disclosure, the printed sub-layer 320 is formed on the insulating sub-layer 310. That is to say, the printed sub-layer 320 is disposed in the groove formed with a CNC machining, etc. In one implementation of the present disclosure, the printed sub-layer 320 may be formed of a polymer film subjected to a printing process and is fixed in the groove by adhesive. The polymer forming the polymer film is also not particularly limited, and may be any polymer the color of which can be changed by printing, and may be flexibly customized by persons skilled in the art. For example, in one implementation of the present

disclosure, the polymer film may be formed from at least one selected from a group consisting of polyethylene terephthalate (PET), polymethyl methacrylate (PMMA), and polycarbonate (PC). For example, in one implementation of the present disclosure, the polymer film may be formed from PET, or may be formed from composite material consisting of PMMA and PC. The polymer film formed from the above-mentioned polymer has a fine printing effect, thereby further improving the uniformity between the outer surface of the polymer film in the slot 200 and the metal substrate 100.

Furthermore, in one implementation of the present disclosure, the polymer film has a structure not particularly limited. For example, in one implementation of the present disclosure, the transparent polymer film formed of PET may have a high gloss surface and a matte surface. The high gloss surface has been subjected to the printing process, and is in contact with the insulating sub-layer 310, while the matte surface is exposed outside. In order to facilitate mass manufacture, firstly, the film is manufactured with the above-mentioned polymer, and cut to size suitable for printing, and then the color of the film is rendered the same as the substrate 100 by printing, for example, the color may be gold, pale pink, silver, or the like. After that, the polymer film with a printed color is punched to form one or more printed sub-layers 320 having a size suitable for being received in the groove. The adhesive formed from, for example, polyurethane or the like is disposed on the insulating sub-layer 310 in the groove, and the printed sub-layer 320 having the suitable size is attached and fixed in the groove.

In one implementation of the present disclosure, the printed sub-layer 320 may have a width 0.02-0.06mm larger than the insulating sub-layer 310. In this way, the

likelihood that the insulating sub-layer 310 is not fully covered due to operation errors can be greatly reduced or avoided. That is to say, it can also be ensured that the insulating sub-layer 310 is fully covered, even if a location misalignment arises to some extent when the groove is formed.

In one implementation of the present disclosure, the printed sub-layer 320 may have a thickness of 0.1-0.3mm which is appropriate since the color of the printed sub-layer 320 may be affected if the thickness thereof is less than 0.1mm while some of the material of the printed sub-layer 320 may be unnecessary if the thickness thereof is larger than 0.3mm.

It should be noted that, in the present disclosure, the conditions of the printing process to which the polymer film forming the printed sub-layer 320 is subjected are not particularly limited, and may be customized by those skilled in the art according to the type of the polymer and the color of the anodized outer surface of the substrate 100. For example, in one implementation of the present disclosure, firstly, a black color may be printed on the polymer film, and then the polymer film may be subjected to one or more black/white color printing processes, thereby rendering the printed color of the initially transparent polymer film more obvious.

In one implementation of the present disclosure, in order to further improve the abrasion resistance of the surface of the printed sub-layer 320 formed of the polymer film, a protective paint layer may be disposed on the polymer film.

According to the present disclosure, by means of the method, the printed sub-layer 320 covering the insulating sub-layer 310 can be formed in the slot 200, and by adjusting the color of the printed sub-layer 320, the color of the printed sub-layer 320 can be effectively and conveniently rendered substantially the same as that of the

outer surface of the substrate 100, thereby obviously reducing the color difference between the slot 200 and the substrate 100, and significantly improving the unity of the mobile terminal.

According to yet another aspect of the present disclosure, a mobile terminal having the foregoing housing and an antenna is provided. The slot of the housing is aligned with the antenna. In one implementation of the present disclosure, the mobile terminal may be a device requiring signal transmission and reception, such as a mobile phone. It should be noted that, the slots 200 as illustrated in Figs. 1 and 2 are merely intended to show the locations of the slots 200 on the outer surface of the housing, and are not to be construed as having an obvious difference in appearance from the other part of the housing. Actually, the printed sub-layer 320 subjected to the printing process is received in the slot 200 in the housing as illustrated in Figs. 1 and 2, and thus, the slot 200 has substantially the same appearance as the substrate 100 having an anodized outer surface.

According to the present disclosure, the mobile terminal has a beautiful appearance, abrasion resistance, and the housing of the mobile terminal has the slot having substantially the same appearance as the metal substrate.

Technical solutions of the present disclosure will be described in detail in conjunction with examples hereinafter. It will be appreciated by persons skilled in the art that, the examples described below are merely to explain the present disclosure, and are not to be construed as a limit to the present disclosure. Methods without specific technologies or conditions in the examples are performed according to technologies or conditions described in documents in the art, or according to product specifications. Reagents or instruments of which manufacturers are not indicated are

commercially available conventional ones.

Example 1

Aluminum alloy material is processed by casting, pressing, and a CNC machining, so as to manufacture a substrate with a slot penetrating through the substrate in the thickness direction of the substrate. Insulating material is injected into the slot. Then the substrate is decontaminated, degreased, subjected to an alkali corrosion process, washed with water, neutralized in a neutralization tank, and washed with water again so as to remove contamination on the outer surface of the substrate.

The outer surface of the substrate is polished, so as to improve the metallic texture of the substrate. After that, the outer surface of the substrate is sandblasted and wiredrawn. Then, the outer surface of the substrate is anodized, so as to form a golden appearance.

A groove used for forming a printed sub-layer subsequently is formed in the upper part of the slot with the CNC machining. The remaining insulating material in the lower part of the slot forms an insulating sub-layer. The groove has a thickness of 0.2mm, the same width and length as the slot.

A high gloss surface of a transparent PET film is subjected to a printing process, and a golden color is printed on the high gloss surface of the PET film. Then, the PET film is punched to form one or more polymer strips having a size suitable for being received in the groove.

Polyurethane is injected into the groove with a nozzle having an inner diameter of 0.1mm, and a continuous adhesive layer is formed at the bottom of the groove. The polymer strip (the matte surface facing upward, the high gloss surface facing downward) is placed into the groove, pressed and fixed, so as to form the printed

sub-layer.

Example 2

The example 2 is similar to the example 1, and differs in that a silver appearance of a substrate is formed by anodizing, and a groove having a thickness of 0.2 mm, the same length as the slot, and a width 0.04mm larger than the slot is formed on the insulating sub-layer; the center of the groove is aligned with the center of the slot, and each side of the groove is 0.02mm beyond the slot; a silver color is printed on the PET film.

In the description of the present disclosure, it should be understood that, orientational or positional relationships indicated by the terms "central", "length", "width", "thickness", "upper", "lower", "inside", "outside", and the like are those as illustrated in accompanying drawings, and are merely for facilitating and simplifying the description of the present disclosure, rather than indicating or implying that the mentioned devices or elements should have specific orientations and should be constructed and operated in specific orientations, and thus cannot be construed as a limit to the present disclosure. The term "outer surface" refers to a surface of a member or structure, such as a housing, facing the outside circumference, while the term "inner surface" refers to a surface of a member or structure, such as a housing, facing the inside of a mobile terminal.

In the present disclosure, unless specified otherwise, the terms "mount", "connect", "couple", "fix", and the like should be broadly understood, and may include, for example, an undetachable connection, a detachable connection, an integral connection, a mechanical connection, an electrical connection, a direct connected, an indirectly connection via an intermediate medium, a communication

between two elements, and an interaction relationship between two elements. For persons skilled in the art, the specific meaning of the foregoing terms in the present disclosure should be understood in light of the specific circumstance.

In the present disclosure, unless specified otherwise, the first feature being "on" or "beneath" the second feature may mean that the first feature may be in direct contact with the second feature, or the first feature may be in indirect contact with the second feature via an intermediate medium. Moreover, the first feature being "on", "over" or "above" the second feature may mean that the first feature is over or above the second feature, or merely mean that the first feature has a horizontal level higher than the second feature. The first feature being "beneath", "under" or "below" the second feature may mean that the first feature is under or below the second feature, or merely mean that the first feature has a horizontal level lower than the second feature.

In the description of this specification, the terms "one implementation", "some implementations", "example", "embodiment", "some examples", or the like are intended to mean that specific features, structures, materials, or characteristics described in conjunction with the implementation or example are included in at least one implementation or example of the present disclosure. In the specification, the exemplary description for the foregoing terms does not necessarily refer to the same implementations or examples. Moreover, the described specific features, structures, materials, or characteristics may be combined in an appropriate way in any one or more implementations or examples. Furthermore, when not conflicting, different implementations or examples described in the specification as well as features in the different implementations or examples may be integrated or combined by persons skilled in the art.

Although the implementations of the disclosure have been illustrated and described above, it should be understood that the foregoing implementations are exemplary and are not to be construed as a limit to the present disclosure. Without departing from the scope of the present disclosure, changes, modifications, substitutions, and variations could be made to the foregoing implementations by persons skilled in the art.

CLAIMS

1. A housing, comprising:
 - a substrate, made of metal;
 - at least one slot, penetrating through the substrate in a thickness direction of the substrate; and
 - a filling layer, received in the at least one slot, and comprising an insulating sub-layer and a printed sub-layer located on the insulating sub-layer.

2. The housing of claim 1, wherein the printed sub-layer has the same width as the insulating sub-layer.

3. The housing of claim 1, wherein the printed sub-layer has a width larger than the insulating sub-layer.

4. The housing of any one of claims 1 to 3, wherein the printed sub-layer is attached on the insulating sub-layer by adhesive.

5. The housing of any one of claims 1 to 4, wherein the printed sub-layer is formed of a polymer film subjected to a printing process, and the printed sub-layer has the same color as an outer surface of the substrate.

6. The housing of any one of claims 1 to 4, wherein an anodized layer is formed on an outer surface of the substrate.

7. The housing of claim 6, wherein the printed sub-layer is formed of a polymer film subjected to a printing process, and the printed sub-layer has the same color as the outer surface of the anodized layer.

8. The housing of any one of claims 5 to 7, wherein the polymer film is formed from at least one selected from a group consisting of PET, PMMA, and PC.

9. A method for manufacturing a housing, comprising:

forming at least one slot in a substrate made of metal and filling the at least one slot with insulating material, wherein the at least one slot penetrates through the substrate in a thickness direction of the substrate;

forming an insulating sub-layer by removing an upper part of the insulating material; and

disposing a printed sub-layer on the insulating sub-layer.

10. The method of claim 9, further comprising forming an anodized layer on an outer surface of the substrate by anodizing the substrate before forming the at least one slot in the substrate made of metal and filling the at least one slot with the insulating material.

11. The method of claim 9 or 10, wherein the forming the insulating sub-layer by removing the upper part of the insulating material comprises forming a groove in the upper part of the at least one slot, wherein the groove has the same width as the insulating sub-layer.

12. The method of claim 9 or 10, wherein the forming the insulating sub-layer by removing the upper part of the insulating material comprises removing the metal adjacent to the upper part of the insulating material in the width direction of the at least one slot to form a groove on the insulating sub-layer, wherein the groove has a width larger than the insulating sub-layer.

13. The method of any one of claims 9 to 12, further comprising disposing adhesive in the groove before disposing the printed sub-layer on the insulating sub-layer.

14. The method of any one of claims 9 to 13, wherein the printed sub-layer is formed of a polymer film subjected to a printing process.

15. A mobile terminal, comprising a housing of any one of claims 1 to 8 and an antenna, wherein the at least one slot is aligned with the antenna.

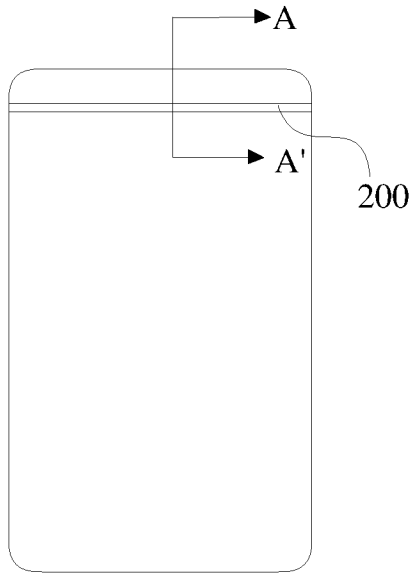

Fig. 1

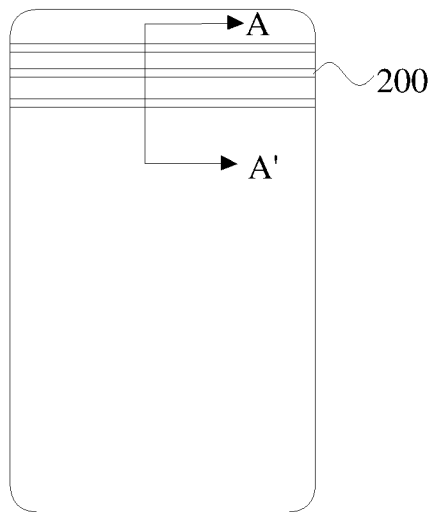

Fig. 2

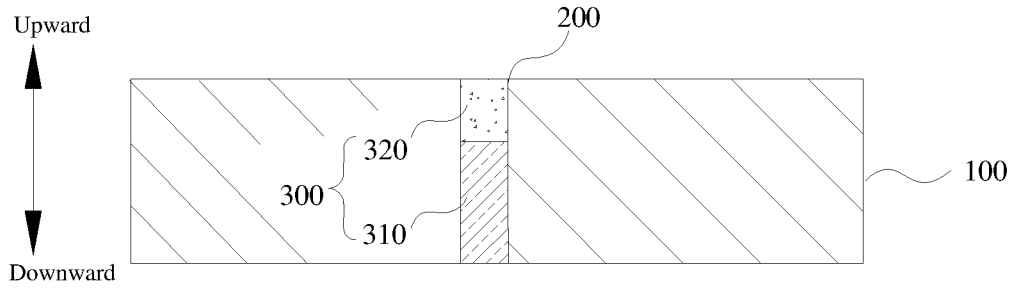

Fig. 3

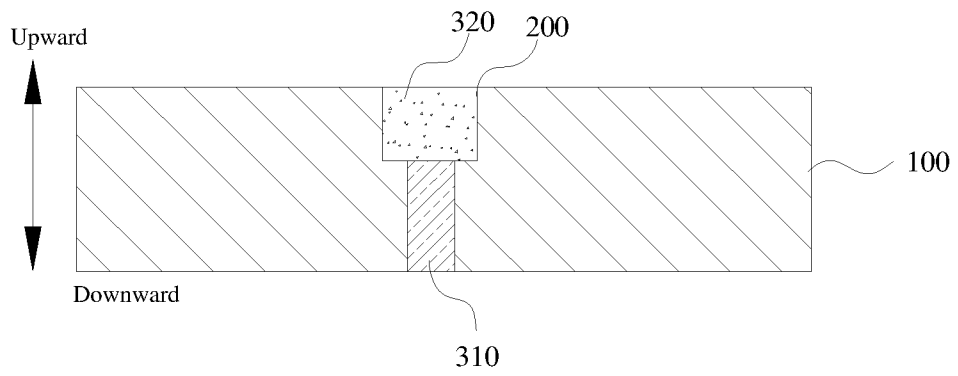

Fig. 4

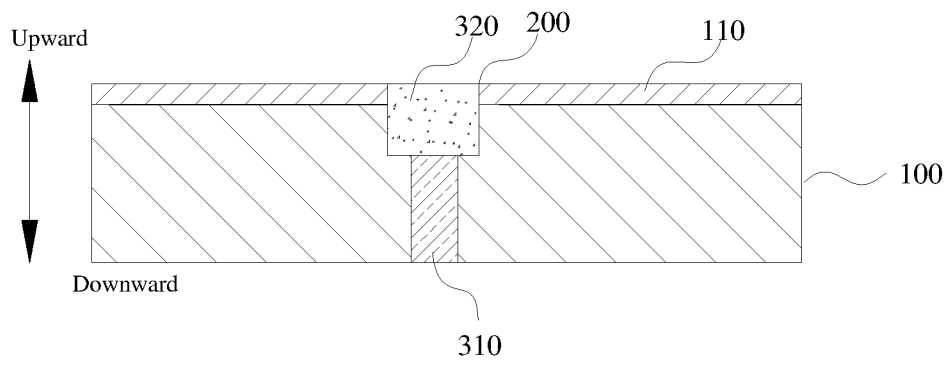

Fig. 5

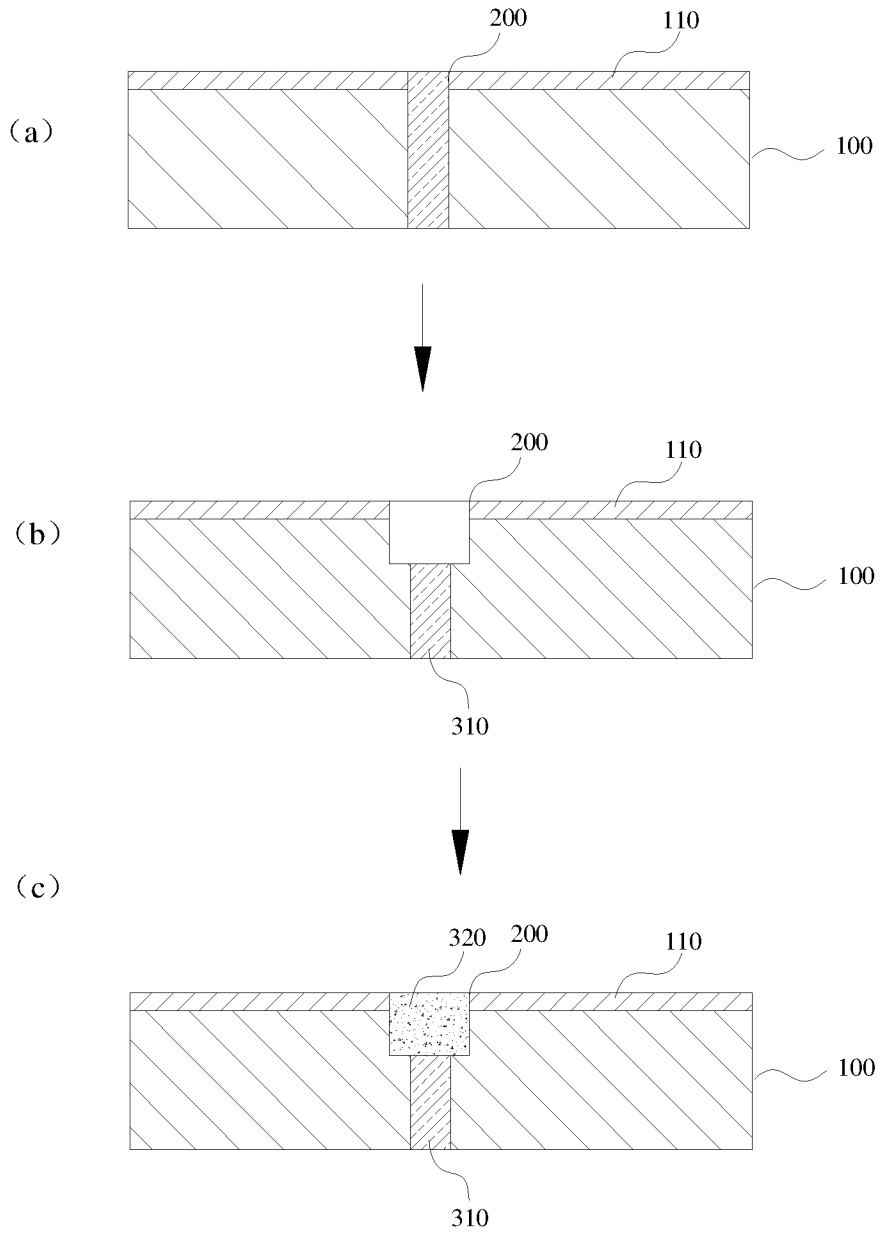

Fig. 6

INTERNATIONAL SEARCH REPORT

International application No.

PCT/CN2017/095559

A. CLASSIFICATION OF SUBJECT MATTER		
H04M 1/02(2006.01)i		
According to International Patent Classification (IPC) or to both national classification and IPC		
B. FIELDS SEARCHED		
Minimum documentation searched (classification system followed by classification symbols)		
H04M		
Documentation searched other than minimum documentation to the extent that such documents are included in the fields searched		
Electronic data base consulted during the international search (name of data base and, where practicable, search terms used)		
CNPAT,CNKI,WPLEPODOC,IEEE:OPPO, mobile, housing, casing, metal, slot, gap, antenna, layer, filling, insulating, print+		
C. DOCUMENTS CONSIDERED TO BE RELEVANT		
Category*	Citation of document, with indication, where appropriate, of the relevant passages	Relevant to claim No.
PX	CN 106231013 A (GUANGDONG OPPO MOBILE TELECOMMUNICATIONS CORP., LTD.) 14 December 2016 (2016-12-14) the whole document	1-15
PX	CN 206181103 U (GUANGDONG OPPO MOBILE TELECOMMUNICATIONS CORP., LTD.) 17 May 2017 (2017-05-17) the whole document	1-15
PX	CN 106132149 A (GUANGDONG OPPO MOBILE TELECOMMUNICATIONS CORP., LTD.) 16 November 2016 (2016-11-16) description, paragraphs [0041]-[0083], and figures 1-11	1-15
X	CN 105517389 A (GUANGDONG OPPO MOBILE TELECOMMUNICATIONS CORP., LTD.) 20 April 2016 (2016-04-20) description, paragraphs [0030]-[0063], and figures 1-3	1-15
X	CN 105813422 A (GUANGDONG OPPO MOBILE TELECOMMUNICATIONS CORP., LTD.) 27 July 2016 (2016-07-27) description, paragraphs [0035]-[0091], and figures 1-13	1-15
A	CN 104580585 A (GUANGDONG OPPO MOBILE TELECOMMUNICATIONS CORP., LTD.) 29 April 2015 (2015-04-29) the whole document	1-15
<input checked="" type="checkbox"/> Further documents are listed in the continuation of Box C. <input checked="" type="checkbox"/> See patent family annex.		
* Special categories of cited documents: "A" document defining the general state of the art which is not considered to be of particular relevance "E" earlier application or patent but published on or after the international filing date "L" document which may throw doubts on priority claim(s) or which is cited to establish the publication date of another citation or other special reason (as specified) "O" document referring to an oral disclosure, use, exhibition or other means "P" document published prior to the international filing date but later than the priority date claimed "T" later document published after the international filing date or priority date and not in conflict with the application but cited to understand the principle or theory underlying the invention "X" document of particular relevance; the claimed invention cannot be considered novel or cannot be considered to involve an inventive step when the document is taken alone "Y" document of particular relevance; the claimed invention cannot be considered to involve an inventive step when the document is combined with one or more other such documents, such combination being obvious to a person skilled in the art "&" document member of the same patent family		
Date of the actual completion of the international search		Date of mailing of the international search report
30 August 2017		10 October 2017
Name and mailing address of the ISA/CN		Authorized officer
STATE INTELLECTUAL PROPERTY OFFICE OF THE P.R.CHINA 6, Xitucheng Rd., Jimen Bridge, Haidian District, Beijing 100088 China		ZHANG,Suqing
Facsimile No. (86-10)62019451		Telephone No. (86-10)61648254

INTERNATIONAL SEARCH REPORT

International application No.

PCT/CN2017/095559

C. DOCUMENTS CONSIDERED TO BE RELEVANT		
Category*	Citation of document, with indication, where appropriate, of the relevant passages	Relevant to claim No.
A	CN 105530784 A (BYD COMPANY LIMITED) 27 April 2016 (2016-04-27) the whole document	1-15
A	KR 20110101350 A (SHIN YANG ENGINEERING CO., LTD.) 16 September 2011 (2011-09-16) the whole document	1-15
A	EP 1950834 A1 (MATSUSHITA ELECTRIC INDUSTRIAL CO., LTD.) 30 July 2008 (2008-07-30) the whole document	1-15

INTERNATIONAL SEARCH REPORT
Information on patent family members

International application No.

PCT/CN2017/095559

Patent document cited in search report			Publication date (day/month/year)	Patent family member(s)	Publication date (day/month/year)
CN	106231013	A	14 December 2016	None	
CN	206181103	U	17 May 2017	None	
CN	106132149	A	16 November 2016	None	
CN	105517389	A	20 April 2016	None	
CN	105813422	A	27 July 2016	None	
CN	104580585	A	29 April 2015	None	
CN	105530784	A	27 April 2016	CN 105530784 B	12 October 2016
				WO 2016101876 A1	30 June 2016
				WO 2016101873 A1	30 June 2016
KR	20110101350	A	16 September 2011	KR 101194736 B1	25 October 2012
EP	1950834	A1	30 July 2008	EP 1950834 B1	29 February 2012