



- (51) International Patent Classification:
F24C 7/08 (2006.01) H05B 1/02 (2006.01)
- (21) International Application Number:
PCT/SE2013/050825
- (22) International Filing Date:
28 June 2013 (28.06.2013)
- (25) Filing Language: English
- (26) Publication Language: English
- (30) Priority Data:
1200441-2 13 July 2012 (13.07.2012) SE
- (71) Applicant: SENSAGON AB [SE/SE]; Första Parkgatan 9,
SE-824 43 Hudiksvall (SE).
- (72) Inventor: BECKIUS, Jan; Skattegårdsvägen 425, SE-162
45 Vällingby (SE).
- (74) Agents: OLSSON, Jan et al.; Bjerkéns Patentbyrå KB,
Box 1274, SE-801 37 Gävle (SE).
- (81) Designated States (unless otherwise indicated, for every
kind of national protection available): AE, AG, AL, AM,

AO, AT, AU, AZ, BA, BB, BG, BH, BN, BR, BW, BY, BZ, CA, CH, CL, CN, CO, CR, CU, CZ, DE, DK, DM, DO, DZ, EC, EE, EG, ES, FI, GB, GD, GE, GH, GM, GT, HN, HR, HU, ID, IL, IN, IS, JP, KE, KG, KN, KP, KR, KZ, LA, LC, LK, LR, LS, LT, LU, LY, MA, MD, ME, MG, MK, MN, MW, MX, MY, MZ, NA, NG, NI, NO, NZ, OM, PA, PE, PG, PH, PL, PT, QA, RO, RS, RU, RW, SC, SD, SE, SG, SK, SL, SM, ST, SV, SY, TH, TJ, TM, TN, TR, TT, TZ, UA, UG, US, UZ, VC, VN, ZA, ZM, ZW.

- (84) Designated States (unless otherwise indicated, for every kind of regional protection available): ARIPO (BW, GH, GM, KE, LR, LS, MW, MZ, NA, RW, SD, SL, SZ, TZ, UG, ZM, ZW), Eurasian (AM, AZ, BY, KG, KZ, RU, TJ, TM), European (AL, AT, BE, BG, CH, CY, CZ, DE, DK, EE, ES, FI, FR, GB, GR, HR, HU, IE, IS, IT, LT, LU, LV, MC, MK, MT, NL, NO, PL, PT, RO, RS, SE, SI, SK, SM, TR), OAPI (BF, BJ, CF, CG, CI, CM, GA, GN, GQ, GW, KM, ML, MR, NE, SN, TD, TG).

Published:
— with international search report (Art. 21(3))

[Continued on next page]

(54) Title: A DEVICE AND A METHOD FOR REDUCING THE TEMPERATURE OF A COOKING DEVICE

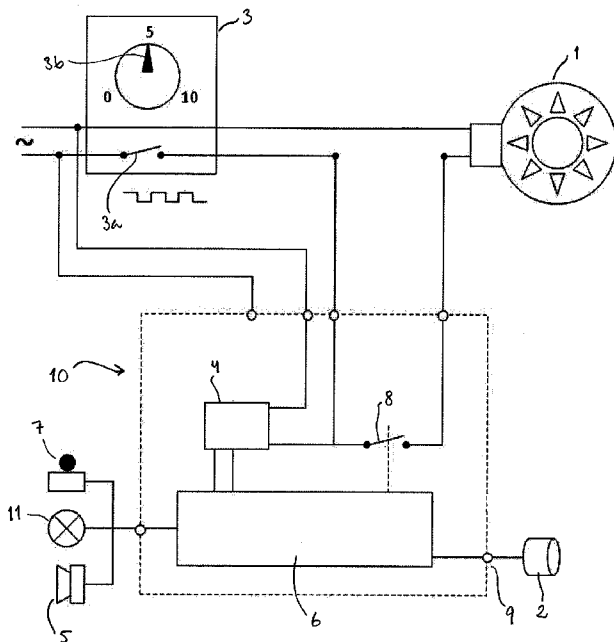

Fig. 2

(57) Abstract: A temperature reducing device (10) for reducing the temperature of at least one hot plate (1) of a cooking device, wherein, when a signal from a sensor (2) indicates that no person is present in the vicinity of the cooking device and when the temperature of the hot plate exceeds a threshold temperature T_0 , a control system (6) adjusts the hot plate to a temperature below the threshold temperature by adjusting the power supplied to the hot plate. The temperature reducing device is configured to determine pulse characteristics of a pulsed voltage supplied to said at least one hot plate and the control system is configured to determine whether the temperature of said at least one hot plate exceeds the threshold temperature based on said pulse characteristics.

WO 2014/011101 A1

- *before the expiration of the time limit for amending the claims and to be republished in the event of receipt of amendments (Rule 48.2(h))*

A device and a method for reducing the temperature of a cooking device

TECHNICAL FIELD OF THE INVENTION

5

The present invention relates to a temperature reducing device for reducing the temperature of at least one hot plate of a cooking device in the form of a cooking stove or a cooking top. The present invention also relates to a method for reducing the temperature of at least one hot plate of a cooking device. The invention is especially directed to such a device and method used in conjunction with the kind of cooking device comprising hot plates with heating elements mounted under a glass ceramic surface.

15

BACKGROUND OF THE INVENTION AND PRIOR ART

A cooking device can heat a cooking utensil with e.g. oil or other fatty substances to such a temperature that the contents catch fire, which may result in a domestic fire. The autoignition temperature for ordinary cooking oil is typically between 350°C and 400°C and a normal cooking temperature is typically around or under 200°C.

25 There are a number of techniques to prevent domestic fires in conjunction with cooking, e.g. so called stove guards which turn the cooking device off based on measurements of outer criteria. It may be for example that the temperature of the cooking utensils exceeds a certain value, that smoke is detected in the vicinity of the cooking device or that no person is detected in the vicinity of the cooking device. It may also be a combination of some or all of these criteria. A common feature for these stove guards is however that they turn the cooking device off upon fulfilment of the chosen criteria, normally by breaking the current supply to the cooking device on one or more phases. 35 The cooking is thus interrupted on all hot plates of the cooking

device until a restart is carried out. This may prevent domestic fires, but the altogether interrupted cooking also leads to inferior cooking results.

5 A temperature reducing device for reducing the temperature of a cooking stove is disclosed in JP2008300182. The temperature reducing device comprises a sensor for sensing the presence of a person in the vicinity of the stove, a control system and a temperature sensor for sensing the temperature of a hot plate of the stove. If no person is detected near the stove during a predetermined time and if the temperature of the hot plate exceeds a threshold value, the power supplied to the stove is adjusted so that the temperature of the hot plate is reduced.

15

SUMMARY OF THE INVENTION

It is an object of the present invention to provide an alternative and in at least some aspect improved way in which the temperature of a hot plate of a cooking device can be reduced if no person is detected in the vicinity of a cooking device. Another object of the invention is to provide a versatile temperature reducing device which can easily be mounted after installation of the cooking device, without the need to mount external or internal temperature sensors.

According to a first aspect of the invention, at least some of these objects are achieved by the temperature reducing device according to claim 1. According to a second aspect of the invention, at least some of these objects are achieved by a method for reducing the temperature of at least one hot plate of a cooking device in the form of a cooking stove or a cooking top according to the independent claim 13.

35 The temperature reducing device according to the invention has the advantage that it does not rely on internal or external

temperature sensors in order to adjust the temperature of a hot plate of a cooking device. The temperature reducing device according to the invention is instead configured to determine whether a threshold temperature is exceeded and, if no person is present in the vicinity of the cooking device, to adjust the temperature of the hot plate based on pulse characteristics of a pulsed voltage supplied to the hot plate. This makes the temperature reducing device easier to mount onto a cooking device after installation of the cooking device than devices comprising internal or external temperature sensors for sensing the temperature of a hot plate.

According to one embodiment of the invention, the control system is configured to continuously calculate the temperature of said at least one hot plate over time using said pulse characteristics and a temperature curve for said at least one hot plate, and to adjust the power supplied to said at least one hot plate based on said calculation only if the threshold temperature T_0 is exceeded. The temperature reducing device according to this embodiment has a control system configured to determine the temperature of the at least one hot plate by using a temperature curve for the hot plate and measuring the pulse duration during which the hot plate is supplied with voltage and from these data continuously calculate the temperature of the hot plate over time. Thus, the temperature reducing device can keep track of the temperature of the hot plate without need for a temperature sensor to sense the temperature of the hot plate. Since the temperature reducing device keeps track of the actual temperature of the hot plate, it only needs to interfere when the threshold temperature is actually exceeded.

According to one embodiment of the invention, the temperature reducing device is configured to individually adjust the power supplied to the at least two hot plates. In this embodiment, it is possible to prevent overheating of a cooking utensil on one hot plate, while normal cooking can be carried out continuously on

another hot plate even when no person is present in the vicinity of the cooking device. For example, a frying pan left unattended at high power will have its temperature reduced to a non-crucial temperature, while potatoes being cooked on another hot plate
5 can continue to cook without disturbance.

Further advantageous features and advantages of the invention are identified in the dependent claims and will also appear from the following description.
10

BRIEF DESCRIPTION OF THE DRAWINGS

Fig. 1a shows schematically a control knob and a hot plate,
15

Fig. 1b shows schematically a hot plate,

Fig. 2 shows schematically a temperature reducing device according to an embodiment of the invention,
20

Fig. 3 shows schematically a temperature curve of a hot plate in the absence of temperature reduction according to the invention,

25 Fig. 4 shows schematically a temperature curve of a hot plate for which the temperature is reduced according to the invention,

30 Fig. 5a-c show schematically how a temperature reducing device according to the invention reduces the pulse duration during which a hot plate is supplied with voltage, and

35 Fig. 6a-b show examples of the temperature of a hot plate during cooling (a) and heating (b), respectively.

DETAILED DESCRIPTION OF EMBODIMENTS OF THE INVENTION

5 A hot plate 1 and a control knob 3 of a cooking device (not shown) in the form of a cooking stove or a cooking top are schematically shown in Fig. 1a. Fig. 1b shows the hot plate in more detail. The hot plate 1 comprises a built-in heating element 1a mounted under a glass ceramic surface 1b, and a protective housing 1c. A cooking device in the form of a cooking stove or a cooking top may comprise several hot plates 1 mounted under the glass ceramic surface 1b. In order to heat the hot plate 1, the heating element 1a is supplied with power adjusted by the control knob 3. The control knob 3 comprises an adjustable bimetallic switch 3a which switches the voltage supply to the hot plate 1 on and off in pulses according to a time schedule depending on the setting of a rotatable pointer 3b comprised in the control knob. The period may vary between 10 s to several minutes depending on the setting of the pointer 3b. When the pointer 3b is turned to its maximum setting, the hot plate 1 is continuously supplied with power via the switch 3a. A thermostat (not shown) is however provided in the heating element 1a for protection against overheating that may result in damages to the glass ceramic surface 1b. The thermostat normally switches the current to the hot plate off at a temperature of around 500-550°C, i.e. well above the autoignition temperature of ordinary cooking oil. In the maximum setting of the control knob 3, the thermostat is normally regularly activated as can be seen from Fig. 3, which schematically shows a temperature curve of a hot plate which is not affected by a temperature reducing device according to the invention.

A temperature reducing device 10 according to an embodiment of the invention is schematically shown in Fig. 2 together with a hot plate 1 and a control knob 3. The temperature reducing device 10 comprises a control system 6 with a logic circuit or a

microprocessor, a switching device 8 for switching the current to the hot plate 1, and an input terminal 4 for measuring the pulsed voltage supply to the hot plate 1. The temperature reducing device further comprises a sensor 2 for detecting the presence of a person and an input terminal 9 for receiving a signal from the sensor 2. The temperature reducing device 10 is connected to the cooking device so that it via the input terminals 4 can measure the pulsed voltage from the control knob 3 to the hot plate 1 and so that it via the switching device 8 can switch the current to the hot plate 1. The sensor 2 for detecting the presence of a person is mounted on or in the immediate vicinity of the cooking device.

The temperature of the hot plate 1 is determined by calculation. For the calculation, it is necessary to know how the temperature of the hot plate 1 develops over time during heating and cooling of the hot plate. Here, this is termed the temperature curve of the hot plate. The temperature curve is determined prior to usage of the temperature reducing device 10, e.g. by measurement using a heat camera or similar, and is stored in the control system 6 as a mathematical expression or as a table. The temperature curve for a hot plate during cooling with no power supplied to the hot plate and during heating with power continuously supplied to the hot plate are shown in Fig. 6a (cooling) and Fig. 6b (heating). The temperature of the hot plate 1 over time can be described as a function of said temperature curve and the current supplied to the hot plate. By means of the input terminal 4, the temperature reducing device 10 measures pulse characteristics such as the pulse duration during which the control knob 3 supplies the hot plate 1 with current and the frequency of these pulses. From the measured pulse characteristics and from the temperature curve of the hot plate 1, the control system 6 calculates how the temperature of the hot plate 1 changes over time. The temperature is calculated by using the measured temperature curve, stored either in the form of a mathematical expression or as a table, of a hot plate.

Knowing the present temperature of the hot plate and the duration of the pulse ΔTime as well as the frequency of the pulses, the control system 6 adds a temperature value $\Delta\text{Temp}+$ or subtracts a temperature value $\Delta\text{Temp}-$ from the present
5 temperature and can thus follow the actual temperature of the hot plate. The calculation of the temperature of the hot plate should be carried out continuously, i.e. also when the hot plate 1 is turned off by means of the control knob 3. In this way, the control system 6 always keeps track of the present temperature
10 of the hot plate 1.

However, the calculation has to be modified at certain control points:

- When the control knob 3 has been turned to the maximum
15 setting for a predetermined time, it can be assumed that the temperature of the hot plate 1 has reached its maximum temperature, and the maximum temperature is assumed to be the present temperature regardless of what the calculation says.
- When the control knob 3 has been turned to zero, i.e.
20 turned off, for a predetermined time, it can be assumed that the temperature of the hot plate 1 is at approximately room temperature, about 20°C, and a corresponding temperature value is used regardless of what the calculation says.
- When the pulse characteristics have been the same for a
25 predetermined time, i.e. the setting of the control knob 3 has remained unchanged during the time, the hot plate 1 will assume a predictable temperature which can be determined by calibration, stored in the control system 6 and used instead of the calculated value.

30

As long as the sensor 2 detects the presence of a person in the vicinity of the cooking device, the temperature reducing device 10 according to the invention only calculates the temperature of the hot plate 1 and lets the person, via the control knob 3 of the
35 cooking device, control the power supplied to the hot plate 1. As long as a person is present near the cooking device, the hot

plate may therefore reach any temperature which is below the temperature at which the thermostat switches the current supply to the hot plate 1 off in order to protect the glass ceramic surface 1b. However, when a person is not detected or has not
5 been detected near the cooking device during a predetermined time, the temperature reducing device checks whether the hot plate 1 exceeds a predetermined threshold temperature T_0 , above which e.g. cooking oil may autoignite and catch fire. The threshold temperature T_0 should be chosen such that the
10 temperature in the cooking utensil is maintained in a range of normal cooking temperatures. A normal cooking temperature is here defined as a temperature below or around 200°C . The predetermined threshold temperature T_0 should therefore be maximum 350°C , preferably maximum 300°C , since the
15 temperature within the cooking utensil will be lower than the temperature of the hot plate. If the threshold temperature T_0 is not exceeded, the power supplied to the hot plate 1 is not affected by the temperature reducing device. If however the temperature of the hot plate 1 exceeds the threshold
20 temperature T_0 , the power supplied to the hot plate 1 is broken by means of the switching device 8 until the calculated temperature of the hot plate 1 is below the threshold temperature T_0 . The control system 6 measures the frequency and duration of the pulses during which voltage is supplied to
25 the hot plate and thereafter only adjusts the power supplied so that the temperature of the hot plate is just below the threshold temperature T_0 as illustrated in Fig. 4. As soon as a person is detected in the vicinity of the cooking device, the temperature reducing device stops interfering with the power supplied to the
30 hot plate 1.

In order to adjust the power supplied to the hot plate 1, the temperature reducing device should know the frequency and duration of the voltage pulses that should be used over a longer
35 period of time in order to reach a temperature just under the threshold temperature. Fig. 5a shows the voltage supplied to a

hot plate 1 when the temperature is above the threshold temperature and Fig. 5b shows the voltage supplied when the hot plate 1 is at a temperature below the threshold temperature. The control system 6 measures the duration and frequency of the pulse by means of which the hot plate is supplied with voltage and thereafter adjusts the pulse duration by switching off the current to the hot plate 1 when or just before the control knob 3 switches on the voltage supplied to the hot plate 1 or a short time before the control knob switches off the voltage supplied as shown in Fig. 5c, wherein the dashed line represents the voltage pulse at a temperature above the threshold temperature and the solid line represents an adjusted pulse duration. Thus, the duration of the voltage pulses is shortened.

15

The temperature reducing device cannot supply the hot plate 1 with current but can only be used to switch off the current supply to the hot plate. Therefore, the temperature reducing device can never give the hot plate 1 a temperature which is higher than the setting of the control knob 3 allows, which is important for security reasons.

20

The temperature reducing device may comprise a signalling device in the form of a signal lamp 7 and/or a buzzer 5, which signals to a user of the cooking device that a temperature adjustment is being or has been performed. The temperature reducing device may also be equipped with a manual override device, here shown in the form of a button 11, configured to allow the hot plate 1 to reach a temperature above the threshold temperature during a predetermined time. When the button 11 is momentarily pressed in, the hot plate is allowed to reach the temperature it is given by the control knob 3 during a predetermined time.

25

30

For a cooking device with several hot plates, preferably four hot plates, the temperature reducing device may comprise a

35

switching device for each hot plate respectively as well as input terminals for measuring pulsed the voltage supplied to each hot plate respectively, or other means for determining the pulse characteristics of each hot plate respectively. The temperature curve of each of the hot plates is stored in the control system. The temperature reducing device may also in this embodiment comprise a single control system and a single sensor for detecting the presence of a person. Such a temperature reducing device can reduce the temperature of several hot plates individually. Thus, it may reduce the temperature of only one hot plate and leave the other hot plates unaffected. This means that cooking at normal cooking temperatures, e.g. simmering, can be continuously carried out also when no person is present in the vicinity of the cooking device. The temperature reducing device may in this embodiment comprise one or several manual override devices. If a single manual override device is used, it may be adapted so as to allow only a specific hot plate, e.g. the hot plate last turned on, to exceed the threshold temperature and only during a set time.

In an embodiment of the invention, the temperature reducing device 10 has a control system 6 which is configured to adjust the power supplied to the hot plate 1 without calculating the actual temperature of the hot plate 1. When the control system 6 via the input terminal 9 receives a signal from the sensor 2 that no person is present in the vicinity of the stove, it checks the pulse characteristics of the pulsed voltage supplied to the hot plate and by means of the switching device 8 adjusts the power supplied to the hot plate 1 such that the pulse length results in a temperature below a predetermined threshold temperature T_0 . Of course, the control system may be configured such that adjustment is only carried out when no person has been detected in the vicinity of the cooking device for a predetermined time.

35

For some cooking devices, the control knob may be replaced by e.g. a touch control panel. In an embodiment of the inventive temperature reducing device adapted for such cooking devices, the control system is configured to receive a signal transmitted
5 by the touch control panel and thereby determine the pulse characteristics of the pulse during which the hot plate is supplied with voltage.

10 The switching device may be one or more relays, triacs or similar, e.g. coupled in series with the current to each hot plate.

The temperature reducing device according to the invention may for example be built into the cooking device or mounted on or next to the cooking device.

15

The invention is not limited to the embodiments disclosed but may be varied and modified within the scope of the following claims.

CLAIMS

1. A temperature reducing device (10) for reducing the temperature of at least one hot plate (1) of a cooking device in the form of a cooking stove or a cooking top, the temperature reducing device comprising
- 5 a control system (6),
at least one switching device (8),
a sensor (2) configured to detect the presence of a person,
10 a first input terminal (9) configured to receive a signal from the sensor (2),
wherein, when the first input terminal (9) receives a signal from the sensor (2) indicating that no person is present in the vicinity of the cooking device, the control system (6) is configured to, by
- 15 means of the switching device (8), adjust the power supplied to the at least one hot plate (1) such that the temperature of said at least one hot plate (1) does not exceed a predetermined threshold temperature T_0 ,
- characterized in**
- 20 that the temperature reducing device (10) is configured to determine pulse characteristics of a pulsed voltage supplied to said at least one hot plate (1) and that the control system (6) is configured to determine whether the temperature of said at least one hot plate exceeds the threshold temperature T_0 based on
- 25 said pulse characteristics.
2. The temperature reducing device according to claim 1, **characterized in** that the control system (6) is configured to continuously calculate the temperature of said at least one hot
- 30 plate (1) over time using said pulse characteristics and a temperature curve for said at least one hot plate (1), and to adjust the power supplied to said at least one hot plate (1) based on said calculation only if the threshold temperature T_0 is exceeded.

3. The temperature reducing device according to claim 2, **characterized in** that the temperature curve for the hot plate (1) is in the form of tabulated values.
- 5 4. The temperature reducing device according to claim 2, **characterized in** that the temperature curve for the hot plate (1) is in the form of a mathematical expression.
- 10 5. The temperature reducing device according to any of the preceding claims, **characterized in** that it comprises at least one second input terminal (4) configured to measure the pulsed voltage supplied to the at least one hot plate (1).
- 15 6. The temperature reducing device according to any of the preceding claims, **characterized in** that the control system (6) is configured to adjust the power supplied to the at least one hot plate (1) by breaking the current to the at least one hot plate (1) so that the pulse length is shortened.
- 20 7. The temperature reducing device according to any of the preceding claims, **characterized in** that the predetermined threshold temperature is maximum 350°C, preferably maximum 300°C.
- 25 8. The temperature reducing device according to any of the preceding claims, **characterized in** that it comprises a signalling device (5, 7) configured to send a signal in consequence of a temperature adjustment performed by the control system (6).
- 30 9. The temperature reducing device according to claim 7, **characterized in** that the signalling device (5, 7) is configured to be mounted on the cooking device.
- 35 10. The temperature reducing device according to any of the preceding claims, **characterized in** that it comprises at least one manual override device (11), which override device (11) is

configured to prevent the control system (6) from adjusting the power supplied to the at least one hot plate (1) during a predetermined time period.

- 5 11. The temperature reducing device according to any of the preceding claims, **characterized in** that it is configured to individually adjust the power supplied to at least two hot plates, preferably four hot plates.
- 10 12. The temperature reducing device according to claim 11 in combination with claim 10, **characterized in** that it comprises means for determining which of the at least two hot plates was last turned on, and in that the override device (11) is configured to prevent the control system (6) from adjusting the power
15 supplied only to the hot plate that was last turned on.
13. A method for reducing the temperature of at least one hot plate (1) of a cooking device in the form of a cooking stove or a cooking top, the method comprising the steps:
- 20 - detecting whether a person is present in the vicinity of the cooking device,
- if no person is present in the vicinity of the cooking device, adjusting the power supplied to the at least one hot plate (1) such that the temperature of said at least one hot plate (1)
25 does not exceed a predetermined threshold temperature T_0 ,
characterized in that the method comprises the step:
- determining pulse characteristics of a pulsed voltage supplied to the at least one hot plate (1) and based on said pulse characteristics determining whether the temperature of
30 said at least one hot plate exceeds the threshold temperature T_0 .
14. The method according to claim 13, characterized in that it comprises the step:

- continuously calculating the temperature of said at least one hot plate (1) over time using said pulse characteristics and a temperature curve for said at least one hot plate (1), and in that the power supplied to said at least one hot plate (1) is adjusted based on said calculation only if the threshold temperature T_0 is exceeded.
- 5

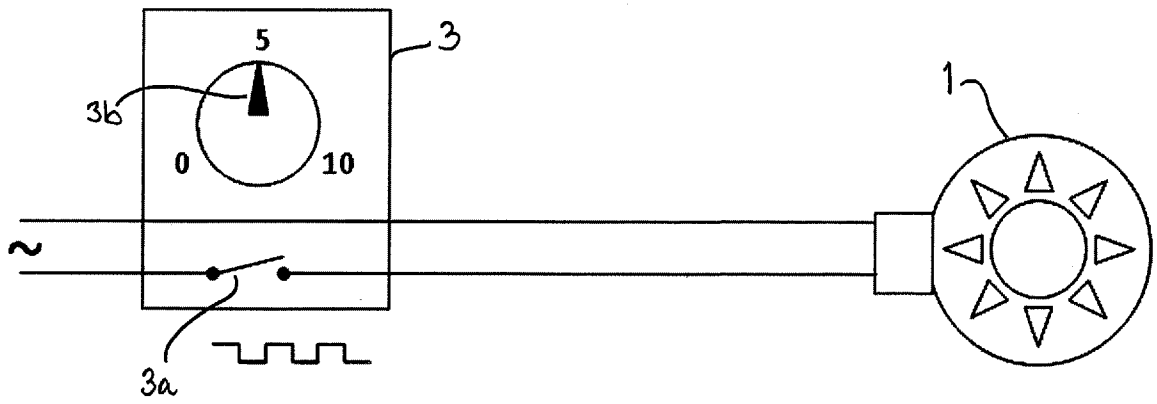

Fig. 1a

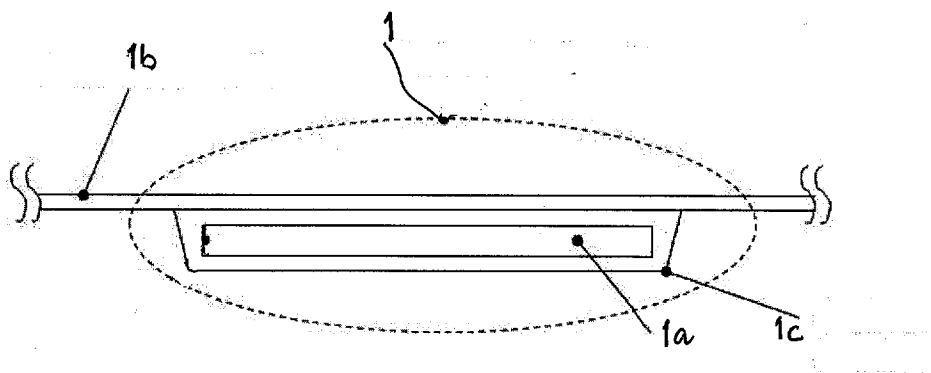

Fig. 1b

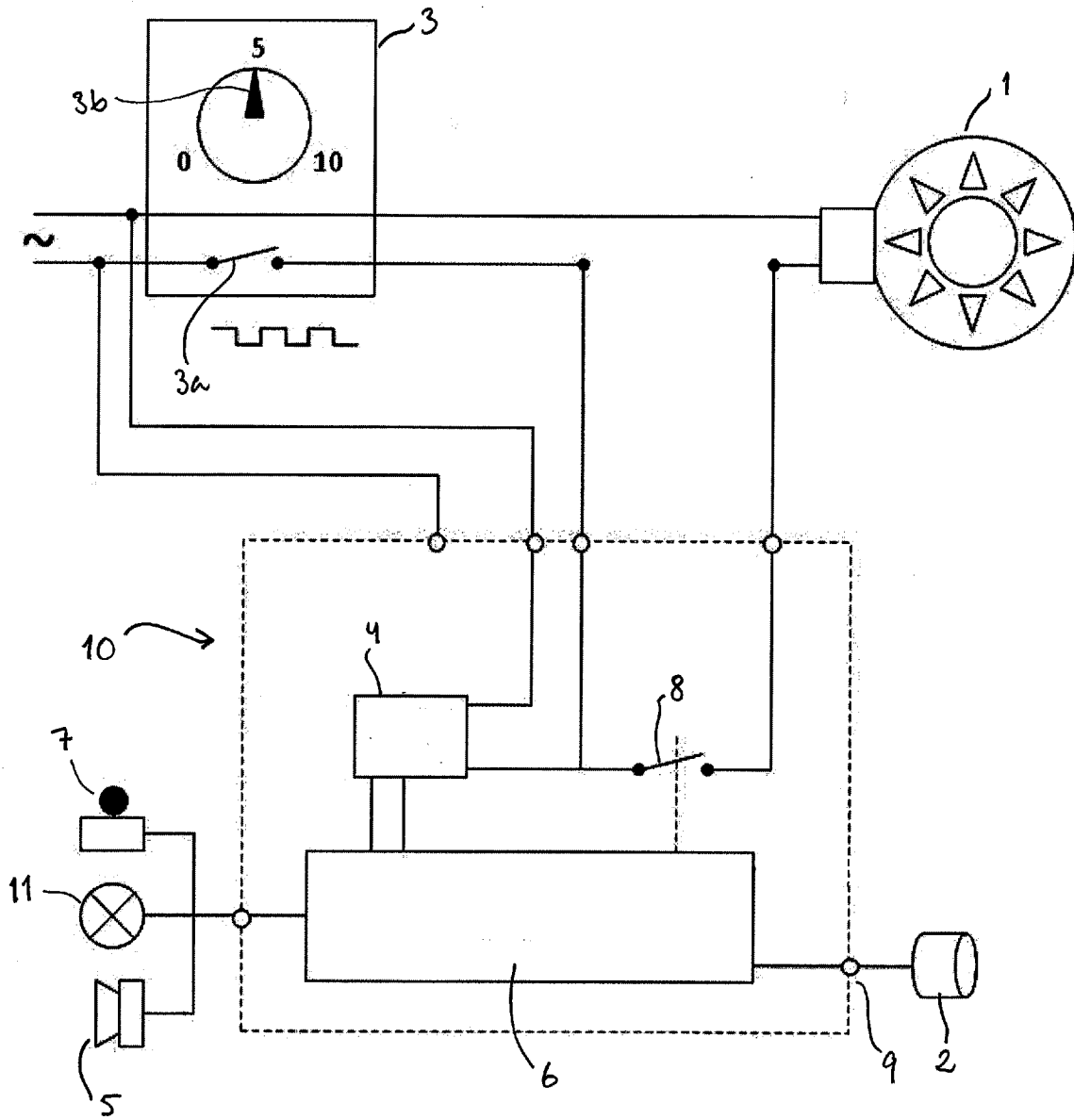

Fig. 2

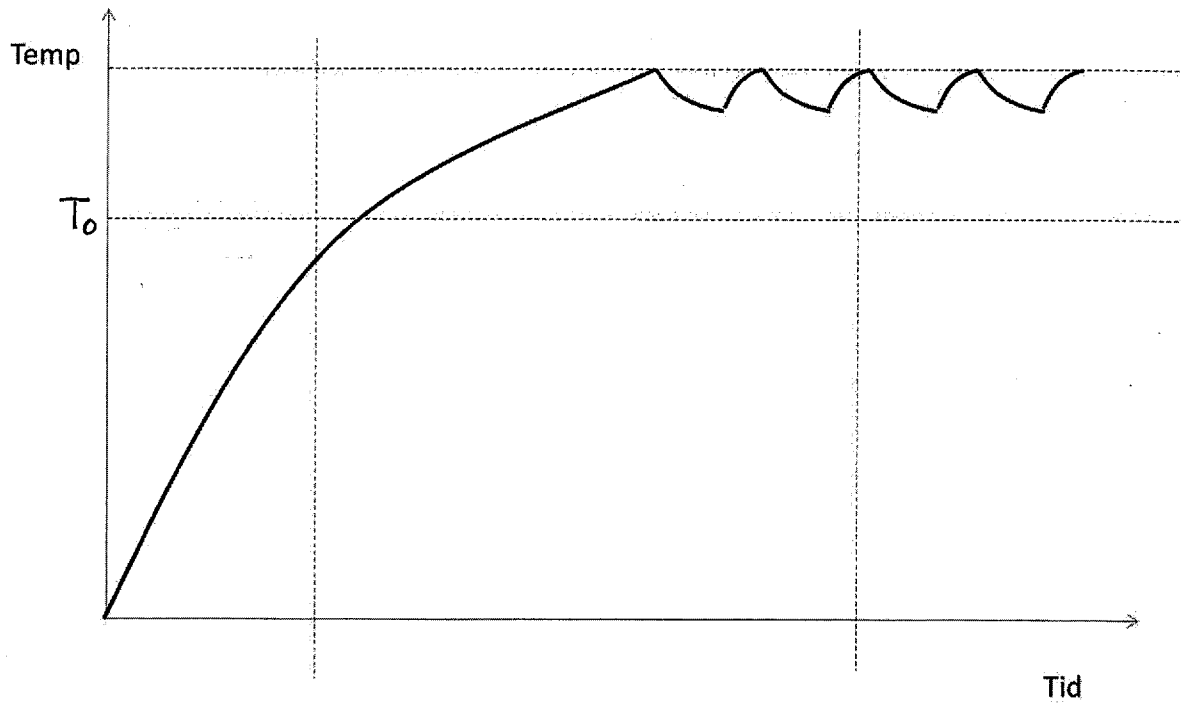

Fig. 3

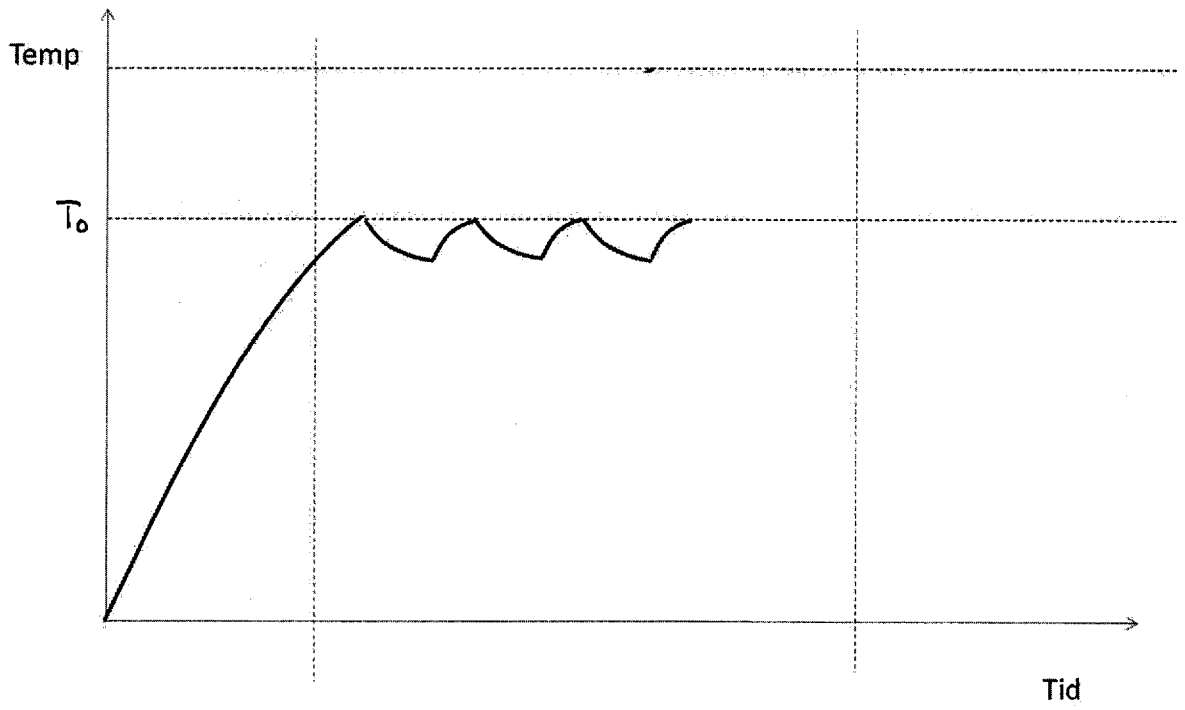

Fig. 4

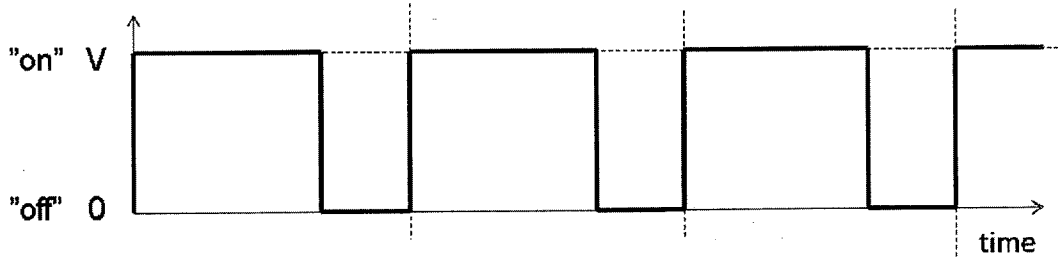

Fig. 5a

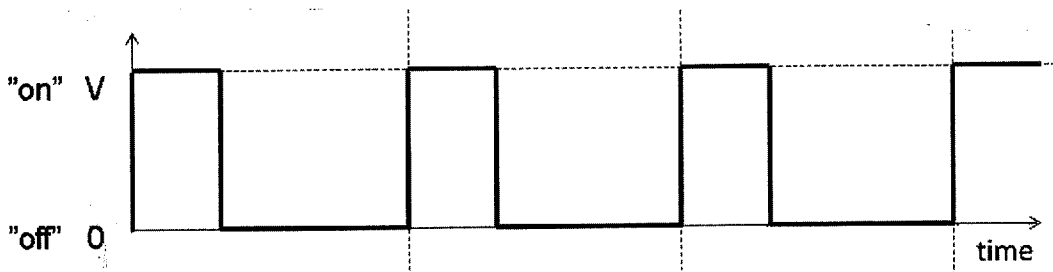

Fig. 5b

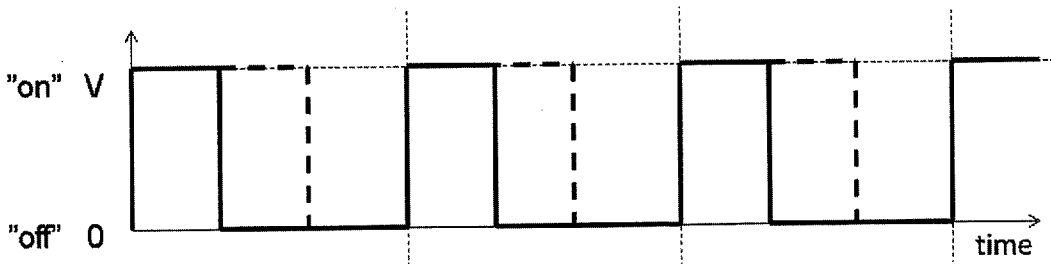

Fig. 5c

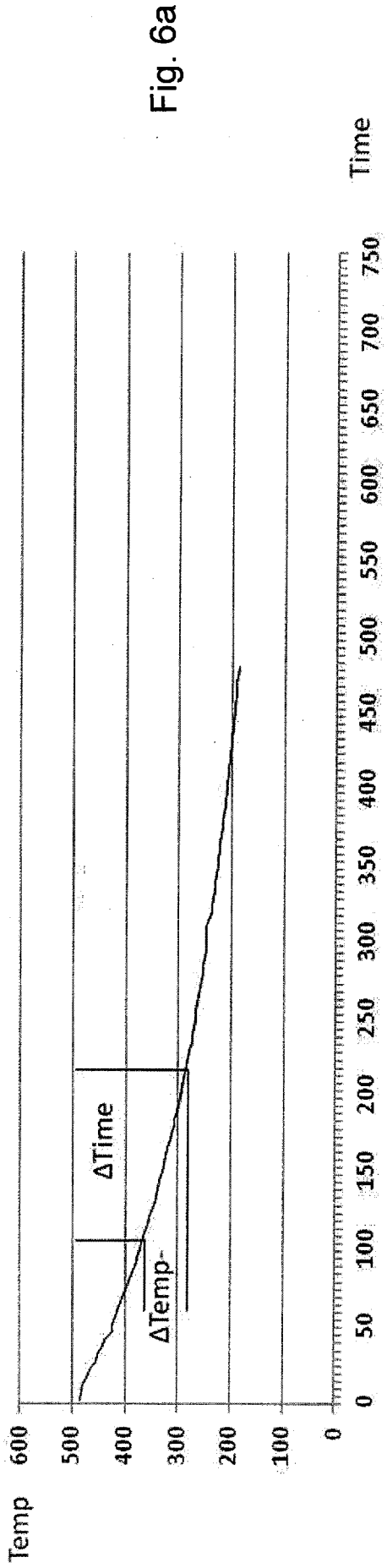

Fig. 6a

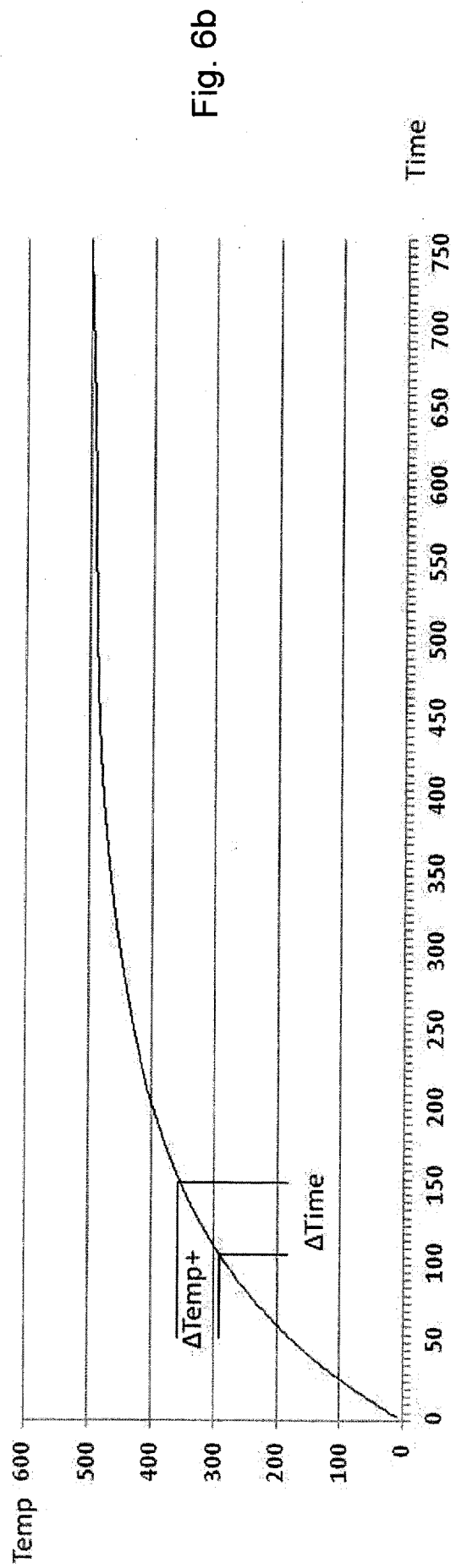

Fig. 6b

INTERNATIONAL SEARCH REPORT

International application No.
PCT/SE2013/050825

A. CLASSIFICATION OF SUBJECT MATTER		
IPC: see extra sheet		
According to International Patent Classification (IPC) or to both national classification and IPC		
B. FIELDS SEARCHED		
Minimum documentation searched (classification system followed by classification symbols)		
IPC: F24C, G05D, H05B		
Documentation searched other than minimum documentation to the extent that such documents are included in the fields searched		
SE, DK, FI, NO classes as above		
Electronic data base consulted during the international search (name of data base and, where practicable, search terms used)		
EPO-Internal, PAJ, WPI data, COMPENDEX, INSPEC		
C. DOCUMENTS CONSIDERED TO BE RELEVANT		
Category*	Citation of document, with indication, where appropriate, of the relevant passages	Relevant to claim No.
A	JP 2008300182 A (PANASONIC CORP), 11 December 2008 (2008-12-11); (abstract) Retrieved from: PAJ database; Original document: Figures 1-5; whole document --	1-14
A	US 3781506 A (KETCHUM M ET AL), 25 December 1973 (1973-12-25); whole document --	1-14
A	JP 2006107814 A (SANYO ELECTRIC CO ET AL), 20 April 2006 (2006-04-20); (abstract) Retrieved from: PAJ database; Original document: Figures 1-7; whole document --	1-14
<input checked="" type="checkbox"/> Further documents are listed in the continuation of Box C. <input checked="" type="checkbox"/> See patent family annex.		
* Special categories of cited documents: "A" document defining the general state of the art which is not considered to be of particular relevance "E" earlier application or patent but published on or after the international filing date "L" document which may throw doubts on priority claim(s) or which is cited to establish the publication date of another citation or other special reason (as specified) "O" document referring to an oral disclosure, use, exhibition or other means "P" document published prior to the international filing date but later than the priority date claimed "T" later document published after the international filing date or priority date and not in conflict with the application but cited to understand the principle or theory underlying the invention "X" document of particular relevance; the claimed invention cannot be considered novel or cannot be considered to involve an inventive step when the document is taken alone "Y" document of particular relevance; the claimed invention cannot be considered to involve an inventive step when the document is combined with one or more other such documents, such combination being obvious to a person skilled in the art "&" document member of the same patent family		
Date of the actual completion of the international search		Date of mailing of the international search report
28-11-2013		02-12-2013
Name and mailing address of the ISA/SE Patent- och registreringsverket Box 5055 S-102 42 STOCKHOLM Facsimile No. + 46 8 666 02 86		Authorized officer Andreas Westberg Telephone No. + 46 8 782 25 00

INTERNATIONAL SEARCH REPORT

International application No.
PCT/SE2013/050825

C (Continuation). DOCUMENTS CONSIDERED TO BE RELEVANT		
Category*	Citation of document, with indication, where appropriate, of the relevant passages	Relevant to claim No.
A	WO 9828944 A1 (RAK JOZEF), 2 July 1998 (1998-07-02); whole document --	1-14
A	US 5717188 A (VAILLANCOURT ALAIN), 10 February 1998 (1998-02-10); whole document -- -----	1-14

Continuation of: second sheet

International Patent Classification (IPC)

F24C 7/08 (2006.01)

H05B 1/02 (2006.01)

INTERNATIONAL SEARCH REPORT

Information on patent family members

International application No.

PCT/SE2013/050825

JP	2008300182 A	11/12/2008	JP	4992553 B2	08/08/2012
US	3781506 A	25/12/1973	NONE		
JP	2006107814 A	20/04/2006	JP	4443366 B2	31/03/2010
WO	9828944 A1	02/07/1998	AU	5472298 A	17/07/1998
			CA	2193533 A1	20/06/1998
US	5717188 A	10/02/1998	CA	2152015 C	22/09/1998