

No. 866,473.

PATENTED SEPT. 17, 1907.

D. C. KEEFE & T. M. SMITH.
ELECTRIC LAMP BRACKET.
APPLICATION FILED JUNE 7, 1906.

2 SHEETS—SHEET 1.

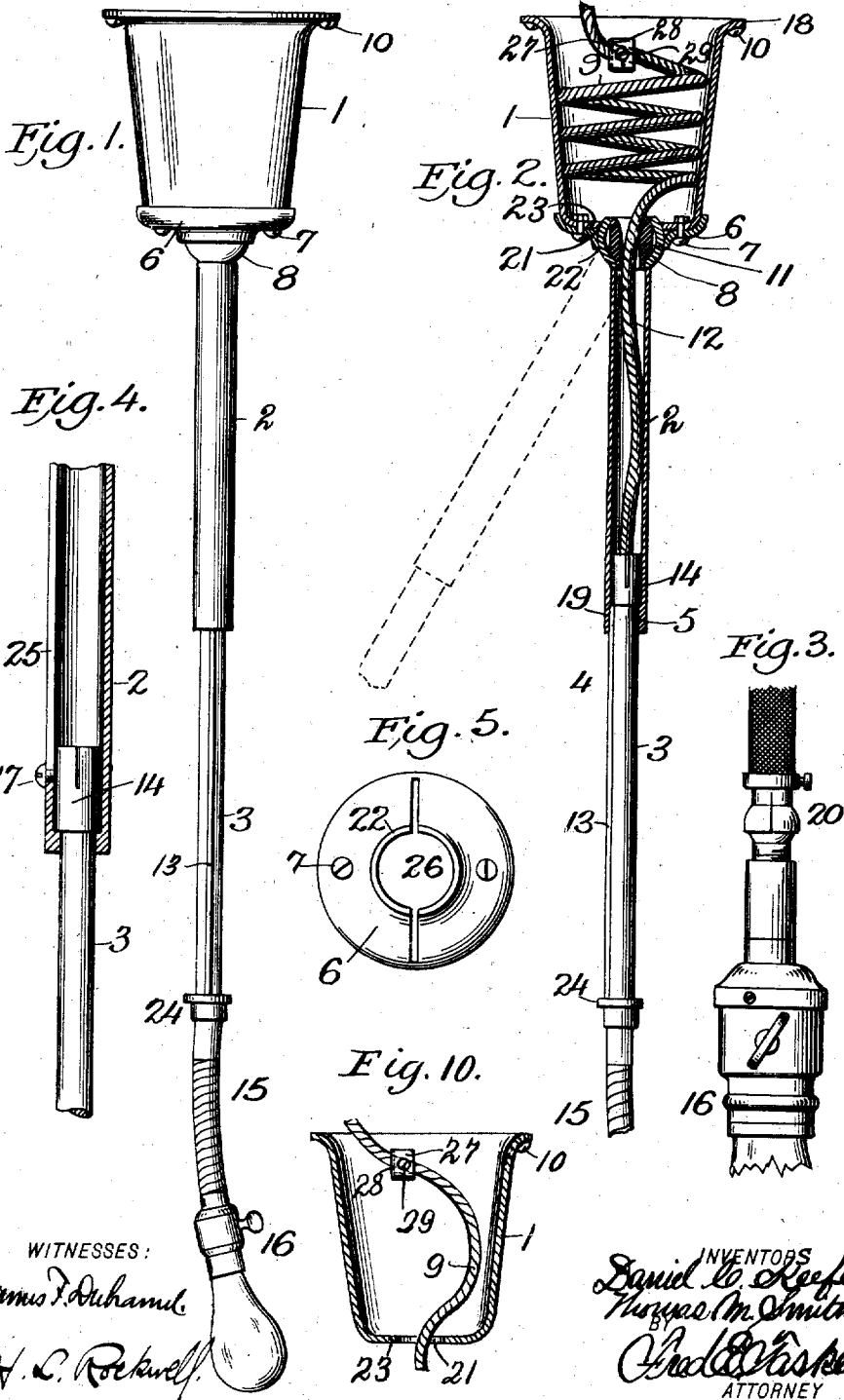

WITNESSES:
James F. Duhamel
H. C. Rockwell

INVENTORS
David C. Keefe
Thomas M. Smith
BY
Charles W. Washburn
ATTORNEY

No. 866,473.

PATENTED SEPT. 17, 1907.

D. C. KEEFE & T. M. SMITH.
ELECTRIC LAMP BRACKET.

APPLICATION FILED JUNE 7, 1908.

2 SHEETS—SHEET 2.

Fig. 6.

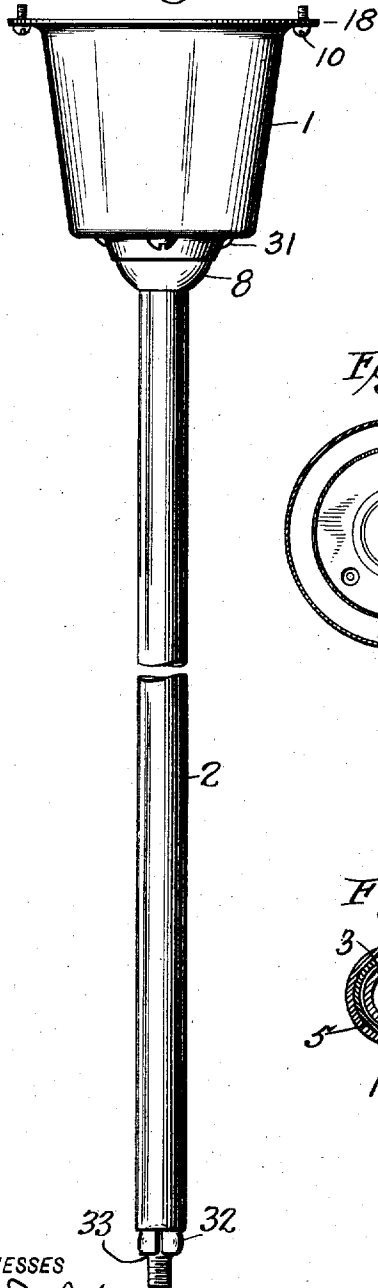

Fig. 7.

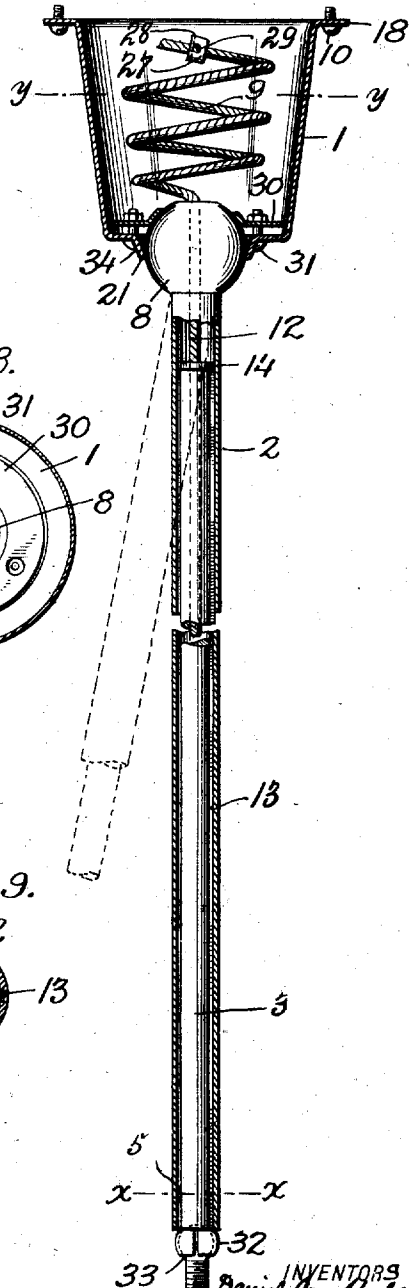

Fig. 8.

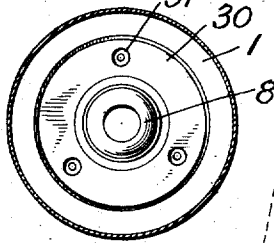
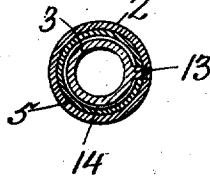

Fig. 9.



WITNESSES
James F. Duhamel
A. S. Rockwell.

INVENTORS
Daniel C. Keefe
Thomas M. Smith
BY
Fred Wisker,
ATTORNEY

UNITED STATES PATENT OFFICE.

DANIEL C. KEEFE AND THOMAS M. SMITH, OF NEW YORK, N. Y.; SAID SMITH ASSIGNOR TO SAID KEEFE.

ELECTRIC-LAMP BRACKET.

No. 866,473.

Specification of Letters Patent.

Patented Sept. 17, 1907.

Application filed June 7, 1906. Serial No. 320,517.

To all whom it may concern:

Be it known that we, DANIEL C. KEEFE and THOMAS M. SMITH, citizens of the United States of America, and residents of the city, county, and State of New York, have invented certain new and useful Improvements in Electric-Lamp Brackets, of which the following is a specification.

Our invention relates to electric lighting appliances and more particularly to a lamp support, having among its objects to provide a lamp support for electric lighting which is capable of being regulated as to length and position, and therefore to allow of a greater number of possible positions of the lamp.

It has further for an object to provide a cup or receptacle within which a coil of wire is retained, the coiling of said wire being automatic correspondingly with the adjustment of the lamp.

Therefore the invention consists in the construction, arrangement and combination of parts hereinafter described and claimed.

Referring to the drawings: Figure 1 is a side view of my improved electric lamp support. Fig. 2 is a longitudinal partial sectional view. Figs. 3 and 4 show modifications of my invention respectively relating to the connection of the lamp and the sliding or telescope attachment of the tubes. Fig. 5 is a bottom view of the spring plate. Fig. 6 is a side elevation of a further modification. Fig. 7 is a longitudinal partial sectional view of the same. Fig. 8 is a sectional view of the cup on line $y y$ of Fig. 7. Fig. 9 is a sectional view on line $x x$ of Fig. 7. Fig. 10 is a sectional view of the cup indicating the movement of the wire within.

1 designates a flaring cup or receptacle for an insulated wire coil 9, said cup being attached to any desirable support, as for instance the ceiling, by means of bolts 10 in a flange 18. Secured in any suitable way, as by soldering for instance, near the top and within said cup is a ferrule or ring 27 parallel, or nearly parallel, with the top of said cup and having an edge 28 rounded in order to save the insulation of the wire. On the insertion of the wire, said ring shunts it inwardly and greatly facilitates the production of a more perfect coil. As shown in Fig. 10, said ring always keeps a partial coil within the cup, and thus at the beginning of the coiling process, provides a starter for the coil. A set-screw 29, carried in a convenient position in said ring 27, bears against the wire and holds it in position to coil within the cup. The base 23 of said cup 1 is provided with a central circular opening 21, and holes formed for the reception of any adjustable means such as bolts 7. Held against the bottom of the cup by these bolts 7, is a spring plate 6 which in part conforms to the shape of the base 23, and flares downward from the bolts 7. The plate 6 is provided

with a central circular opening 26, which is so formed as to make a spring socket 22. Said socket 22, shown in Fig. 5, is slitted to insure greater spring, and flanged to provide a firmer grip and allow the adjustment in any position of a hollow ball 8. Said ball 8 is provided with diametrically opposite openings. Secured in said openings is a bushing 11, which lies flush with the top and bottom of said ball 8, and allows the passage of the wire 12 from cup 1 into a tube 2, which is secured in any suitable way to the bottom of said ball. Said tube 2 is provided with a longitudinal groove 19 of greater or less length which receives a spline 13 on an inner telescoping tube 3, said engagement preventing the rotation of the tube 3 relatively to tube 2 and the consequent twisting of the wire 12, which would result in the disarrangement of the coil 9. The lower end of said tube 2 is provided with a similarly grooved interior shoulder 5 against which a shoulder 14 on the lower tube 3 strikes when at the completion of its downward movement, thus preventing the disengagement of the extensible wire-covering tubes 2 and 3. The tube 3 is provided at the lower end of the spline 13 with a fixed collar 24 which lies flush with the surface of the tube 2 when the tube 3 is at the completion of its upward movement. Adjacent to said collar 24, the tube 3 is also provided with a suitably attached flexible member 15 which carries the lamp 16.

Instead of the spline 13 and groove 19, a modification of our invention shown in Fig. 4, provides a slot 25 in tube 2, and a screw or bolt 17 screwed in the shoulder 14 of tube 3, and operating in said slot 25 in the same manner as spline 13 on the tube 3.

Another modification of our invention, shown in Fig. 3, embodies the use of a ball and socket joint 20 instead of the flexible connection 15.

A still further modification is shown in Figs. 6, 7, 8, and 9. In this form, the cup 1 is provided with a downwardly extending flange 34 which encircles the opening 21 and supports the ball 8. Within the cup and firmly pressing against said ball above the opening 21 is an upwardly extending spring plate 30 secured to the bottom of the cup by any means, preferably bolts 31 which govern the pressure of said plate upon the ball 8 and the resulting movement of said ball 8 with the socket thus formed by the flange 34 and plate 30. A further application of our invention in this modified form is a slitted spring socket 32, carried by the lamp-carrying end of the tube 3 and adapted to contain and grip an open hollow ball 33, similar in form and movement to the ball 8.

The operation of our invention, in so far as it has not been already described, is as follows: With the tube 3 in the position indicated by Figs. 1 and 2, on a slight upward force being applied to said tube, the wire is forced into the coil through the assistance of the ring

27, and the tube 3 assumes any desired position in the tube 2 where it is retained by friction. In this way, the lamp may be raised or lowered in accordance with the wish of the user; while should the movement desired be lateral, by a slight pressure in the necessary direction, the entire tubing may be adjusted as shown by the dotted lines in Figs. 2 and 7, the ball 8 operating in the spring socket 22 formed by the base 17 and the spring plate 6, and the wire being readily supplied in any direction from the receptacle 1, or the ball 8 operating in the socket formed by flange 34 and plate 30.

Our invention provides an extensible lamp support which is capable of adjustment as to length or position; a lamp support which at all times incloses the wire in a neat casing; and a lamp support which coils or uncoils the wire in a cup automatically with the movement of the telescoping tubes. Further, the use of a spline, as a preventive of the turning of the tubes and the resulting twisting of the wires, removes all danger of the breaking or twisting off of the wires or of the wearing off of their insulation, either of which would result in a short circuit and the consequent endangering of the premises by fire.

While we have shown several modifications of the invention, it is not practical to illustrate all of them.

However, we reserve the right to use any or all modified forms which may appear desirable in the construction of the device, so long as said modification be found in accordance with the spirit of the invention.

Having thus described our invention what we claim as new and desire to secure by Letters-Patent, is:—

In a lamp support, the combination of a cup which provides a receptacle wherein the electrical conductor automatically coils and uncoils, an extensible lamp-carrying tube consisting of an upper tube and a lower tube, and means for preventing the rotation of said tubes relatively to each other, a ball on the end of the lamp-carrying tube, a spring plate secured to the cup and having a circular opening receiving and retaining the ball in different positions, a conductor running through the lamp-carrying tube and coiling within the cup, and means for facilitating the winding and unwinding of the coil, consisting of a guide device secured to the wall of the cup and having an approximately horizontal passage through it, through which passage the conductor runs so that it may be deflected at the proper angle to allow it to easily coil and uncoil, substantially as described.

Signed at New York this 6th day of June 1906.

DANIEL C. KEEFFE.
THOMAS M. SMITH.

Witnesses:
JOHN H. HAZELTON,
C. B. SCHROEDER.