



(72) YEAP, Tet Hin, CA

(71) BELL CANADA, CA

(51) Int.Cl.<sup>6</sup> H04J 3/18, H04B 1/66

(54) **METHODE ET APPAREIL POUR L'ENCODAGE DE SIGNAUX NUMERIQUES DESTINES A LA TRANSMISSION ET/OU AU STOCKAGE, ET POUR LE DECODAGE DE TELS SIGNAUX SUITE A LA TRANSMISSIONS ET/OU AU STOCKAGE**

(54) **METHOD AND APPARATUS FOR ENCODING OF DIGITAL SIGNALS FOR TRANSMISSION AND/OR STORAGE, AND DECODING SUCH ENCODED SIGNALS FOLLOWING SUCH TRANSMISSION AND/OR STORAGE**

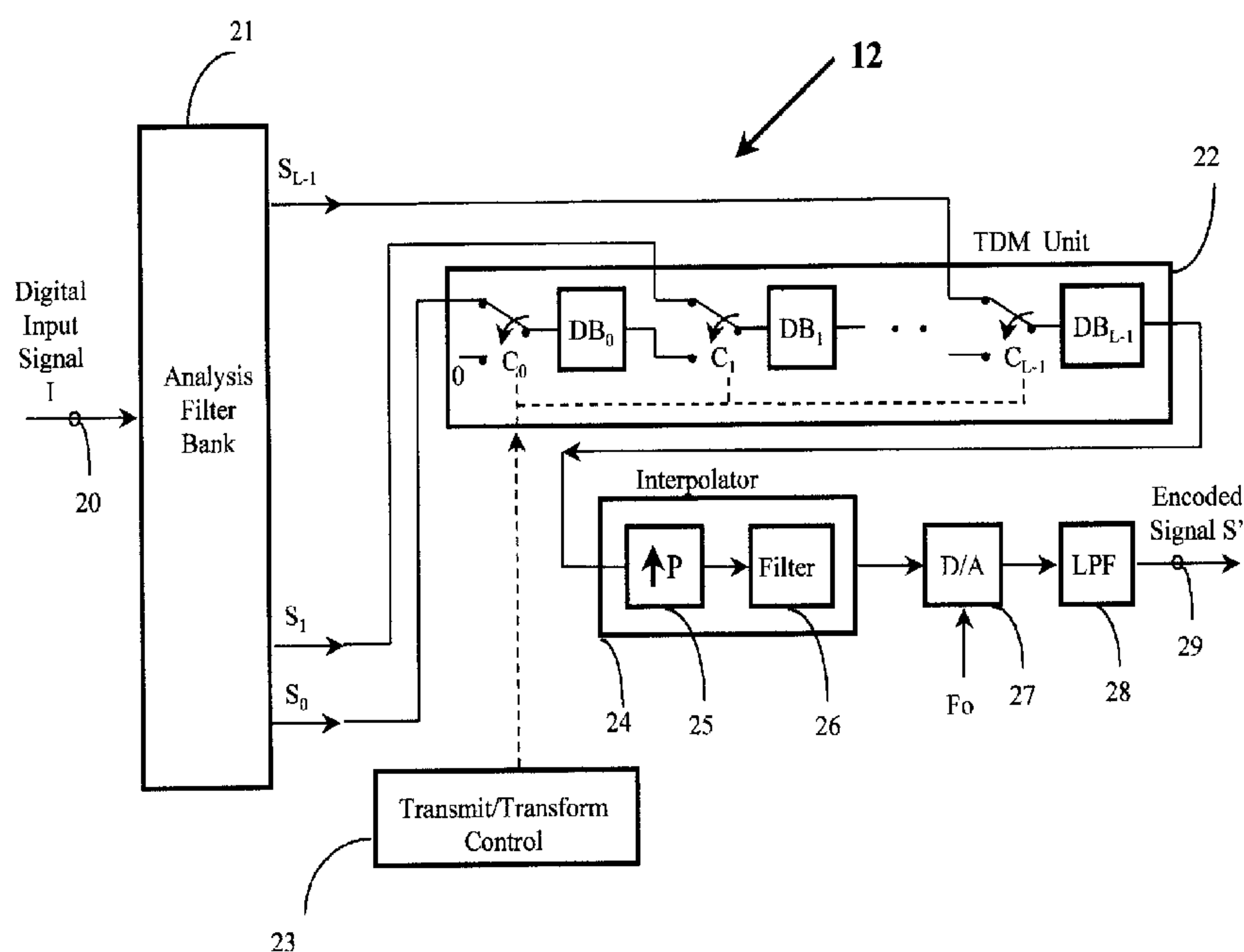

(57) Digital signals for transmission and/or storage are encoded by an encoder comprising an analysis filter bank for converting each digital signal into a plurality of subband signals. Some or all of the subband signals are upsampled to produce a plurality of signals each having a frequency spectrum in which segments are duplicated, each duplicate segment having a bandwidth no greater than a prescribed bandwidth of a transmission channel or storage means. The encoder selects one of the duplicates for each subband upsampled and time division multiplexes the selected duplicates to form an encoded signal for transmission or storage. Following reception/extraction, the encoded signal is decoded by a decoder which downsamples the received encoded signal at a rate that corresponds to that used by the encoder to upsample the subband signals, demultiplexes the downsampled signal to provide a plurality of received subband signals corresponding to the subband signals in the encoder, and processes the subband signals in a synthesis filter bank to form a reconstructed decoded signal corresponding to the digital input signal.



## ABSTRACT OF THE DISCLOSURE

Digital signals for transmission and/or storage are encoded by an encoder comprising an analysis filter bank for converting each digital signal into a plurality of  
5 subband signals. Some or all of the subband signals are upsampled to produce a plurality of signals each having a frequency spectrum in which segments are duplicated, each duplicate segment having a bandwidth no greater than a prescribed bandwidth of a transmission channel or storage means. The encoder selects one of the duplicates for each subband upsampled and time division multiplexes the selected duplicates to form  
10 an encoded signal for transmission or storage. Following reception/extraction, the encoded signal is decoded by a decoder which downsamples the received encoded signal at a rate that corresponds to that used by the encoder to upsample the subband signals, demultiplexes the downsampled signal to provide a plurality of received subband signals corresponding to the subband signals in the encoder, and processes the subband signals  
15 in a synthesis filter bank to form a reconstructed decoded signal corresponding to the digital input signal.

METHOD AND APPARATUS FOR ENCODING OF DIGITAL SIGNALS FOR TRANSMISSION AND/OR STORAGE, AND DECODING SUCH ENCODED SIGNALS FOLLOWING SUCH TRANSMISSION AND/OR STORAGE

5 DESCRIPTION

TECHNICAL FIELD:

The invention relates to a method and apparatus for encoding digital signals for transmission and/or storage, and decoding such encoded signals after such transmission and/or storage. The invention is especially, but not exclusively, applicable to the  
10 encoding of digital signals for transmission via communications channels, such as twisted wire pair subscriber loops in telecommunications systems, or to storage of signals in or on a storage medium, such as video signal recordings, audio recordings, data storage in computer systems, and so on.

15 BACKGROUND ART:

Embodiments of the invention are especially applicable to the transmission of digital signals over Very High Speed Digital Subscriber Loops (VDSL) at bit rates of, perhaps, 20 Mbits/second or higher in the existing subscriber loops, which cannot readily be achieved with conventional systems in which there is a tendency, when transmitting  
20 at high bit rates, to lose a portion of the signal, typically the higher frequency part, causing the signal quality to suffer significantly. This is particularly acute in two-wire subscriber loops, such as so-called twisted wire pairs.

The invention is particularly concerned with the use of an analysis filter bank to decompose the signal to be transmitted/stored into a plurality of subband signals. The  
25 term "subband signals" sometimes is used to refer to a plurality of narrowband signals within a prescribed band of interest, perhaps obtained by a corresponding plurality of bandpass filters. The present invention, however, is concerned with subband signals produced by an analysis filter bank as disclosed in an article entitled "Perfect-channel Splitting By Use of Interpolation and Decimation Tree Decomposition Techniques",  
30 Proc. Intl. Conf. Inform. Sci. Syst., pp. 443-446, Aug. 1976, by A. Crosier, D. Esteban and C. Galand. Crosier *et al* disclosed an analysis filter bank in the form of a quadrature mirror filter (QMF) bank. For a more recent discussion of subband transforms, which include certain wavelet transforms, the reader is directed to an article entitled "Wavelet and Subband Transforms: Fundamentals and communication Applications", Ali N.

Akansu *et al*, IEEE Communications Magazine, Vol. 35, No. 12, December 1997. Both of these articles are incorporated herein by reference.

As explained by Akansu *et al*, in discrete-time signal processing, it is known that the sampling rate can be reduced by splitting the frequency band using Finite Impulse  
5 Response (FIR) filters. Each time one splits the band into a number of parts, for example halves, the sampling rate is reduced by the same number. Hence, repeatedly splitting the frequency band can enable the signal to be processed at a much lower sampling rate. Unfortunately, overlap between the different bands causes aliasing problems. As discussed by Crosier *et al*, to split the frequency band exactly so as to allow "perfect  
10 reconstruction" of the original signal would require using so-called "brick" filters, i.e. FIR filters of infinite duration, which neither overlapped nor left gaps. In practice, this is not possible, so Crosier *et al* proposed limiting the time duration using weighting functions which allow the subbands to overlap yet provide perfect reconstruction, at least theoretically. Difficulties arise in choosing a weighting function such that the  
15 reconstructed signal is distortion free or a so-called "perfect reconstruction". However, providing the analysis filter bank and synthesis filter bank satisfy certain conditions, as set out in the article by Akansu *et al*, "perfect reconstruction" can be achieved.

In a practical implementation, such as in a telecommunications system, some distortion may be acceptable, so it may be possible to use an analysis filter bank which  
20 does not quite meet the conditions set out in Akansu *et al*'s article, and provides only so-called "pseudo perfect reconstruction".

In the context of the present invention, and hereafter in this specification, the term "analysis filter bank" refers to a filter bank meeting the afore-mentioned conditions for "perfect reconstruction", or the conditions for "pseudo-perfect reconstruction", and  
25 the term "subband signals" refers to signals produced by such an analysis filter bank.

It is known to use subband filtering processing signals for transmission and/or storage, but with certain practical limitations. For example, in US Patent No. 5,214,678, J.D. Rault disclosed a system which uses an analysis filter bank to divide a digital input signal into a plurality of subbands. The subbands either are transmitted separately via the  
30 transmission medium or, in the case of a recording system, each applied to a respective one of a plurality of recording heads and recorded individually. Upon reception or retrieval of the individual subband signals, a synthesis filter is used to recombine them into a reconstructed version of the original digital signal. Thus, the subband signals are

not combined for either transmission or storage. A disadvantage of this approach is that it requires as many transmission channels or recording heads as there are subband signals.

As another example, U.S. Patent No. 5,161,210 by Druydesteyn discloses a  
5 system for injecting a tone into an audio signal. An analysis filter bank splits the audio signal into subband signals and an auxiliary tone is injected into each of the subband signals which then are recombined using a synthesis filter. Hence, the recombined signal applied to the transmission medium/storage means is the original signal plus the injected tone and so requires at least the same bandwidth as the original signal.

10 It was generally accepted that, where the subband signals are produced by downsampling a digital signal having a low sampling rate, the subband signals could not be combined before transmission/storage because their bandwidth was too broad, being virtually unlimited. In the analysis filter bank, the original signal is divided into a plurality of narrowband signals, each having a bandwidth considerably narrower than the  
15 bandwidth of either the original signal or the transmission channel through which the signal is to be transmitted. However, each of these narrowband signals must be downsampled to create a subband signal. The downsampling produces a subband signal which has a frequency spectrum having a bandwidth much greater than not only the original narrowband signal but also the transmission medium.

20 In International patent application number WO 9809383, the present inventor Yeap *et al* disclose a technique for combining subband signals before transmission and/or storage which uses an analysis filter to produce a series of subband signals, interpolates the subband signals and uses the interpolated signals to modulate a corresponding plurality of carrier signals which then are combined to form the encoded signal to be  
25 transmitted and/or stored. Upon reception/retrieval, the signal is decomposed into subband signals again which are decimated and applied to a synthesis filter to reconstruct the original signal.

Copending Canadian patent application No. 2,214,287 by the present inventor discloses the use of an analysis filter to produce subband signals which are interpolated  
30 and used for Quadrature Amplitude Modulation (QAM) of a pair of carriers. Each subband signal has two spectral lobes, one each side of the carrier frequency  $f_0$  used for the QAM. Each lobe contains information from both subband signals, so the transmitted/stored signal is less susceptible to corruption by noise. In certain

circumstances, one lobe may be removed by filtering and the original signal still reconstructed.

Thus, interpolating the subband signals and using them to modulate one or more carrier signals to be transmitted as a single signal avoids duplication of transmission/recording channels and allows better recovery of the original signal in the presence of attenuation and radio frequency interference, i.e. from radio stations. Nevertheless, the transmitted/recorded signals may still be susceptible to impulse noise which characteristically occupies a very wide frequency spectrum for a relatively short duration. Also, WO 9809383 and CA 2,214,287 teach modulation of carriers resulting in a passband signal only.

#### DISCLOSURE OF INVENTION:

The present invention seeks to provide a method and apparatus for encoding digital signals using subband signals which is less susceptible to distortion or corruption by impulse noise.

According to one aspect of the present invention, there is provided apparatus for encoding digital signals for transmission and/or storage and decoding such encoded signals after transmission and/or storage, the apparatus comprising an encoder and a decoder, the encoder having input means for the digital signal, analysis filter bank means for converting the digital signal into a plurality of subband signals, means for upsampling each of some or all of said subband signals to produce a plurality of upsampled subband signals each having a frequency spectrum in which segments are duplicated, each duplicate having a bandwidth no greater than a prescribed bandwidth of a transmission channel or storage means, filter means selecting one of the duplicates of each of the selected subband signals, and multiplexing means for time division multiplexing the selected duplicates to form an encoded signal for transmission or storage, the decoder having decoder input means for downsampling the received encoded signal at a rate that corresponds to that used by the encoder to upsample the subband signals, demultiplexing means for demultiplexing the downsampled signal to provide a plurality of received subband signals corresponding to said subband signals in the encoder, and synthesis filter bank means complementary to the analysis filter bank means for processing the plurality of received subband signals to form a reconstructed decoded signal corresponding to said digital input signal.

According to a second aspect of the present invention, there is provided an encoder for encoding digital signals for transmission and/or storage comprising input means for the digital signal, analysis filter bank means for converting the digital signal into a plurality of subband signals, means for upsampling each of some or all of said  
5 subband signals to produce a plurality of upsampled signals each having a frequency spectrum in which segments are duplicated, each duplicate having a bandwidth no greater than a prescribed bandwidth of a transmission channel or storage means, means for selecting one of the duplicates of each of the selected subband signals, and multiplexing means for time division multiplexing the remaining duplicates to form an encoded signal  
10 for transmission or storage.

According to a third aspect of the present invention, there is provided a decoder for decoding digital signals from an encoder according to the second aspect, the decoder having decoder input means for downsampling the received encoded signal at a rate corresponding to that used by the encoder to upsample the subband signals,  
15 demultiplexing means for demultiplexing the downsampled signal to provide a plurality of received subband signals corresponding to said subband signals in the encoder, and a synthesis filter bank for processing the plurality of received subband signals to form a reconstructed decoded signal corresponding to the digital input signal encoded by the encoder.

20 In preferred embodiments, the upsampling rate is equal to the number of subbands produced by the analysis filter bank means.

Preferably, the subband signals are time division multiplexed (TDM) for transmission and/or storage. Preferably the time division multiplexing is performed before the upsampling and interpolation filtering.

25 Preferably, the selected subband signals are upsampled and duplicates selected so that the transmitted/stored duplicates have substantially identical bandwidths which, preferably, optimize transmission/storage channel bandwidth utilization. For subscriber loops, a low pass filter may be used for interpolation and duplicate selection. For other applications, a bandpass or high pass filter may be used.

30 Preferably, the characteristics of a filter used for duplicate selection are selected to optimize channel bandwidth.

Further aspects of the invention comprise methods of encoding and/or decoding corresponding to the first three aspects of the invention, respectively.

**BRIEF DESCRIPTION OF THE DRAWINGS:**

Various features and advantages of the present invention will become apparent from the following description, taken in conjunction with the attached drawings, of preferred embodiments of the invention which are described by way of example only.

5 Figure 1 is a simplified block schematic diagram illustrating a transmission system including an encoder and decoder according to the invention;

Figure 2 is a simplified block schematic diagram of an encoder including a first embodiment of the invention;

Figure 3 is a decoder complementary to the encoder of Figure 2;

10 Figure 4 illustrates a delay bank suitable for use for either the encoder or the decoder;

Figure 5A illustrates a 4-band analysis filter bank of the encoder of Figure 2;

Figure 5B illustrates a corresponding synthesis filter bank of the decoder of Figure 3;

15 Figure 6 is a block schematic diagram of an encoder using two subband signals.

Figure 7 is a block schematic diagram of a decoder complementary to the encoder of Figure 6;

Figure 8 shows the idealized frequency spectrum of the input signal to be encoded;

20 Figure 9 shows the idealized frequency spectra of two narrowband signals  $S_i^*$  and  $S_j^*$  after bandpass filtering but prior to downsampling in an analysis filter bank of the encoder of Figure 6;

Figure 10 is the frequency spectrum of one of the subband signals after downsampling in the analysis filter bank of the encoder of Figure 6; and

25 Figure 11 illustrates the frequency spectrum of the output or encoded signal  $S'$ .

**BEST MODE(S) FOR CARRYING OUT THE INVENTION:**

As illustrated in Figure 1, a typical telecommunications transmission system embodying the present invention comprises a signal source 10 which supplies an  
30 information signal to a transmitter 11 which produce a corresponding digital signal  $I$  and applies it to encoder 12. The transmitter 11 may use a known form of modulation, such as Quadrature Amplitude Modulation (QAM), Carrierless Amplitude/Phase Modulation (CAP), Discrete Multitone Modulation (DMT) or a variety of other forms of modulation

that produce a digital signal  $I$  directly; or produce a signal that can be sampled to produce digital signal  $I$ . Encoder 12 encodes the digital signal  $I$  to provide an encoded signal  $S'$  which it applies to the transmission medium 13.

The transmission medium 13 is illustrated schematically as comprising a transmission channel 14 and a noise source 16. A summer 16 adds noise from source 16 to the signal in the transmission channel 14. It should be appreciated that the transmission medium 13 could be a storage medium instead, such as a video/audio recorder, computer storage device, and so on, and the same schematic representation would apply by analogy.

10 The signal extracted from the transmission medium 13 is applied to a decoder 17 which is complementary to the encoder 12. The decoded signal is supplied to a receiver unit 18 which demodulates the decoded signal and supplies it to the signal destination 19.

The transmitter 11 and receiver 18 may be constructed in a manner that is well known to persons skilled in this art and so will not be described in detail here.

15 The encoder 12 will now be described, generically, with reference to Figure 2. The digital input signal  $I$  is applied via input port 20 to an analysis filter bank 21 which subdivides the signal into a plurality of subband signals  $S_0$  to  $S_{N-1}$  as will be described in more detail later. A selection of the subband signals  $S_0, S_1 \dots S_{L-1}$  are applied to a corresponding plurality of delay banks  $DB_0$  through  $DB_{L-1}$ , respectively, in time division multiplexing (TDM) unit 22. The time division multiplexing unit 22 multiplexes the selected subset of subband signals  $S_0$  to  $S_{L-1}$  to produce a serial signal. This is necessary because the analysis filter bank 21 generates the individual values of the subband signals  $S_0$  to  $S_{L-1}$  simultaneously, i.e., in parallel.

The inputs of the delay banks  $DB_0 - DB_{L-1}$  are connected to the poles of a set of changeover switches  $C_0 - C_{L-1}$ , respectively. One terminal of each of the switches  $C_0 - C_{L-1}$  is connected to a corresponding one of the outputs of the analysis filter bank 21 and, with the exception of switch  $C_0$ , the other terminal is connected to the output of the preceding one of the delay banks  $DB_0 - DB_{L-1}$ . The other terminal of switch  $C_0$  is connected to a suitable source of a zero value. Hence, a first setting of the switches  $C_0 - C_{L-1}$  connects the delay banks  $DB_1$  through  $DB_{L-1}$  in parallel to respective outputs of the analysis filter bank 21 to receive the subband signals  $S_0$  to  $S_{L-1}$ , respectively. A second setting of switches  $C_0 - C_{L-1}$  connects the delay banks  $DB_0$  through  $DB_{L-1}$  in series with each other to receive a series of zero values. The switches  $C_0 - C_{L-1}$  are controlled by a

transmit/transform control unit 23 which switches them alternately between their first and second settings. With the switches in the first setting, each of the delay banks  $DB_0$  through  $DB_{L-1}$  is filled with a string of values of the corresponding subband signal, which values will be clocked into the delay bank under the control of a clock (not shown) until  
 5 it reaches capacity. When the delay banks  $DB_0$  through  $DB_{L-1}$  are all full, the control unit 23 operates switches  $C_0 - C_{L-1}$  and, in the second setting, the contents of the delay banks are clocked out serially.

In this particular embodiment, the computations by the analysis filter bank 21 are suspended while the TDM unit 22 is outputting the serial stream of values. As will be  
 10 described later, in practice, the delay banks  $DB_0$  through  $DB_{L-1}$  could be duplicated so as to provide a continuous signal without interrupting computations.

The multiplexed values from the output of the time division multiplexing unit 22 are applied to an interpolation unit 24 which comprises an upsampler 25 and an interpolation filter 26. The upsampling rate  $P$  will be determined according to specific  
 15 system requirements, such as the number of subbands ( $M$ ) created by the analysis filter bank 21 and desired degree of expansion of each subband signal, but generally will be at such a rate that the bandwidth of each upsampled subband signal will be equal to or slightly less than the bandwidth of the transmission channel 13.

The interpolation filter 26 interpolates between each pair of actual sample values  
 20 to provide an interpolated sample value for insertion in the or each intervening upsampled bit interval. The interpolated signal  $S''$  is converted to an analog signal by a digital-to-analog converter 27, with a sampling rate  $F_0$ , and a lowpass filter 28 removes quantization noise before supplying the encoded signal  $S'$  to output port 29 connected to the transmission medium 13. The processing of the received encoded signal in the  
 25 decoder 17, to reconstruct the original signal  $I$ , will now be described with reference to Figure 3. In the decoder 17, the signal from the transmission medium 13 is received via port 30 and supplied to a typical receiver front end unit represented by amplifier 31 for amplifying the attenuated signal. The amplified signal from amplifier 31 is converted by an analog-to-digital converter 32 which has a sampling rate  $F_0$  that is the same as the  
 30 sampling rate of D/A converter 27 (Figure 2). Typically, if upsampling rate  $P$  is equal to downsampling rate  $M$ , then output sampling rate  $F_0$  is equal to  $L$  (number of selected subbands) times  $F_s$ , the input signal sampling frequency. Thus, for two subbands,  $F_0 = 2F_s$ . A bandpass filter 33 with a bandwidth equivalent to that of the transmission

medium 13 filters the digital signal to remove noise occurring outside the channel bandwidth, following which the filtered digital signal is downsampled by a downsampler 34. The downsampling rate  $P$  is the same as the upsampling rate of upsampler 25 (Figure 2). The downsampled signal is demultiplexed by demultiplexing unit 35 which  
 5 is similar in configuration to the multiplexer unit 22 of Figure 2 in that it comprises a series of delay banks  $DB_0, DB_1, \dots, DB_{L-1}$  interconnected by switches  $C_0 - C_{L-1}$  controlled by a transform/receive control unit 36, but differs in that they are connected in reverse order.

Each of the delay banks  $DB_0 - DB_{L-1}$  in Figures 2 and 3 is identical to the others.  
 10 One of them is illustrated in Figure 4 and comprises a series of unit delay elements  $Z^{-1} = M/F_s$  where  $M$  is the downsampling rate in the analysis filter bank 21 and  $F_s$  is the sampling frequency of the digital input signal  $I$ .

The transform/receive control unit 36 operates the switches  $C_0 - C_{L-1}$  so that the delay banks  $DB_0$  through  $DB_{L-1}$  accumulate the values of the received signal and, when  
 15 a complete sequence has been stored in the delay banks  $DB_0 - DB_{L-1}$ , connects them in parallel to output their contents to the respective inputs of a synthesis filter bank 37 which recombines them to recover the original signal which it provides as output signal  $I'$  at output port 38.

The analysis filter bank 21 (Figure 2) and the synthesis filter bank 37 (Figure 3)  
 20 are complementary and designed to provide "pseudo perfect reconstruction" as described earlier.

Figure 5A shows a suitable analysis filter bank 21 comprising a lowpass filter  $h_0$ , two bandpass filters  $h_1$  and  $h_2$  and a highpass filter  $h_3$  connected in common to receive the digital input signal  $I$  and split it into four narrowband signals  $S_0^*, S_1^*, S_2^*$  and  $S_3^*$ ,  
 25 respectively. A corresponding set of downsamplers 50, 51, 52 and 53 operate upon the signals  $S_0^* - S_3^*$  from the four bandpass filters  $h_0 - h_3$ , respectively, downsampling them by a factor of four to produce four subband signals  $S_0, S_1, S_2, S_3$ , respectively. Each downsampled subband signal has  $N/4$  samples, where  $N$  is the number of samples in the input signal  $I$ . It may be found, in practice, that some of the subband signals have very  
 30 little energy. Consequently, in some applications, they can be discarded and only a selection of the subband signals transmitted. In the specific application to a subscriber loop, such as a twisted wire pair in a telephone system, it is envisaged that only two of the subband signals may need to be transmitted, as will be described later.

As shown in Figure 5B, the synthesis filter bank 37 at the decoder (Figure 3) comprises a set of four upsamplers 54 - 57 for upsampling, by a factor of 4, each of the demultiplexed subband signals  $S_0' - S_4'$ , respectively. The upsampled subband signals are each applied to a corresponding one of a set of four filters, namely a lowpass filter  $h_0'$ , two bandpass filters  $h_1'$  and  $h_2'$ , and a highpass filter  $h_3'$ . It should be noted that the filters  $h_0'$ ,  $h_1'$ ,  $h_2'$ , and  $h_3'$  in the synthesis filter bank 37 are **not** identical to the filters  $h_0$ ,  $h_1$ ,  $h_2$  and  $h_3$  in the analysis filter bank 21. The relationship between the analysis filter bank 21 and the synthesis filter bank 37, and especially the coefficients of their filters, is known to those skilled in this art and so will not be described in detail here. For details, the reader is directed to chapter 7 entitled "Multirate Signal Processing" of the text book "Advanced Digital Signal Processing: Theory and Applications", by G. Zelniker and F. Taylor, publ. Marcel Dekker, Inc., and to the technical literature, including the articles by Akansu *et al* and by Crosier *et al supra*.

The outputs of the filters  $h_0'$ ,  $h_1'$ ,  $h_2'$ , and  $h_3'$  are summed by a summing device 58 to obtain the reconstructed signal  $I'$  for supplying to the signal destination 19 (Figure 1).

It is desirable for the analysis filter bank to perform its computations continuously. An encoder which uses only two subband signals and processes them continuously will now be described, by way of example, with reference to Figure 6, in which components corresponding or identical to components in Figure 2 have the same reference numeral, but with a prime. Thus, the digital input signal  $I$  supplied to input port 20' of analysis filter bank 21' is applied in common to narrowband filters  $h_i$  and  $h_j$ . The narrowband signals from the filters  $h_i$  and  $h_j$  are downsampled by downsamplers 50' and 51', respectively, to form subband signals  $S_i$  and  $S_j$ . The two subband signals  $S_i$  and  $S_j$  are multiplexed by a time division multiplex unit 22' which differs from that in Figure 2 in that it comprises two delay bank units 22A and 22B which both operate upon the two subband signals  $S_i$  and  $S_j$  alternately. There are only two subband signals, so each of the delay bank units 22A and 22B comprises two delay banks  $DB_0$  and  $DB_1$ , which may be identical to those described with reference to Figure 4. The length of each of these delay banks  $DB_i$  would be a design decision and typically might be 128 or 256 integers long. It should be noted that, in this case, each output from the analysis filter bank 21 (Figure 2) will be an integer number.

In delay bank unit 22A, switch  $C_0'$  connects the input of first delay  $DB_0'$  to either the output of the downsampler 50' in analysis filter bank 21' to receive subband signal  $S_i$ ; or to a zero value point. Second switch  $C_1'$  connects the input of second delay bank  $DB_1'$  to the output of downsampler 51' in the analysis filter 21' to receive subband signal  $S_j$ ; or to the output of delay bank  $DB_0'$ .

Delay bank unit 22B comprises two delay banks  $DB_2'$  and  $DB_3'$  and two switches  $C_2'$  and  $C_3'$  connected in a similar manner to those of delay bank unit 22A, but switches  $C_2'$  and  $C_3'$  are poled oppositely to switches  $C_0'$  and  $C_1'$  of delay bank unit 22A. The outputs of delay bank units 22A and 22B are connected to respective terminals of a selector switch  $C_5$ , the pole of which is connected to the input of interpolating unit 24'.

The switches  $C_0'$  to  $C_5'$  are controlled by transmit/transform control unit 23' so that, when subband signal values are being clocked into the delay banks  $DB_0'$  and  $DB_1'$  of delay bank unit 22A, the values in the delay banks  $DB_2'$  and  $DB_3'$  of delay bank unit 22B are being clocked out to the interpolation unit 24' and replaced by zeros. Conversely, when the subband signal values are being clocked into delay banks  $DB_2'$  and  $DB_3'$ , the values in delay banks  $DB_0'$  and  $DB_1'$  are being clocked out to the interpolation unit 24'.

As before, the interpolation unit 24' comprises an upsampler 25', which upsamples the time-multiplexed subband signals by a factor  $P$  which is related to the downsampling rate  $M$  and the sampling rate  $F_s$  as described previously. The interpolation filter 26' may be a Raise-Cosine filter which is a low pass filter, or a bandpass filter, depending upon the application. As previously described, the serial data stream then is converted by D/A converter 27' and the resulting analog signal filtered by lowpass filter 28' to remove quantization noise before being applied to the transmission medium 13 as signal  $S'$ .

Referring now to Figure 7, the corresponding decoder comprises an input port 30' whereby the received encoded signal is applied to an amplifier 31', A/D convert 32', filter 33' and downsampler 34' which process is in the manner previously described with reference to the corresponding components shown in Figure 3. Filter 33' will have the substantially same bandwidth as filter 26' in the encoder (Figure 6). Demultiplexing unit 35' is similar to the multiplexing unit 22' in the encoder of Figure 6 in that it comprises two delay bank units 35A and 35B connected in parallel between the output of downsampler 34' and synthesis filter bank 37'. Delay bank unit 35A comprises two

delay banks  $DB_0'$  and  $DB_1'$ , and two changeover switches  $C_0'$  and  $C_1'$ . The output of delay bank  $DB_1'$  is connected to the pole of switch  $C_1'$ , which has one of its terminals connected to one of the inputs of synthesis filter 37' and the other free. The output of delay bank  $DB_0'$  is connected to the pole switch  $C_0'$  which has one of its terminals  
 5 connected to the input of delay bank  $DB_1'$  and the other terminal connected to the other input of synthesis filter 37'.

The second delay bank unit 35B is similar to first delay bank unit 35A in that it comprises delay banks  $DB_2'$  and  $DB_3'$  and switches  $C_2'$  and  $C_3'$ . The inputs of delay bank  $DB_0'$  of delay bank unit 35A and delay bank  $DB_2'$  of delay bank unit 35B are  
 10 connected to the first and second terminals, respectively, of a changeover switch  $C_5'$ , the pole of which is connected to the output of downsampler 34'. The five switches  $C_0'$  -  $C_5'$  are controlled by transform/receive control unit 36'. The switches  $C_0'$  and  $C_1'$  are poled oppositely to switches  $C_2'$  and  $C_3'$  so that, when values of the downsampled received signal are being clocked into delay bank unit 35A, the previously-stored values  
 15 are being clocked out of delay bank unit 35B to the synthesis filter bank 37'; and vice versa.

Operation of the encoder of Figure 6 will now be described with reference also to Figures 8, 9, 10 and 11 which illustrate, in very simplified form, the various signals in the encoder. Thus, Figure 8 shows the frequency spectrum of a digital input signal  
 20 I having a bandwidth BW of about 8 MHz centred upon a centre frequency  $fc_1$  of 5 MHz. These are typical values for a digital input signal that is produced by Quadrature Amplitude Modulation (QAM) as proposed for Very High Speed Digital subscriber loop (VDSL) applications. The maximum frequency of the input signal I is around 9 MHz which is somewhat less than half of the sampling frequency  $F_s$  used by the QAM system  
 25 which, for example, might range from at least 24 MHz to as much as 50 or 60 MHz. The frequency spectrum is symmetrical about the zero ordinal, i.e., there are two conjugate lobes that are symmetrical about zero. The frequency spectrum of a digital input signal I produced by Carrierless Amplitude Phase Modulation (CAP) would be similar.

30 Figure 9 illustrates the two narrowband signals  $S_i^*$  and  $S_j^*$  which are obtained by passing the digital input signal I through bandpass filters  $h_i$  and  $h_j$ , respectively (Figure 6). At each side of the zero ordinal, the two narrowband signals  $S_i^*$  and  $S_j^*$  generally occupy higher- and lower- frequency portions of the bandwidth BW and overlap adjacent

the centre frequency  $fc_1$ . This overlapping of the two narrowband signals  $S_i^*$  and  $S_j^*$  is characteristic of analysis filter banks used for so-called pseudo perfect reconstruction or perfect reconstruction.

When the narrowband signals  $S_i^*$  and  $S_j^*$  are downsampled by a factor of  $M$ ,  
 5 their bandwidth increases by the factor  $M$ . For the QAM example of Figure 9, the subband signals  $S_i^*$  and  $S_j^*$  each occupy at least 6 MHz, so the downsampled signals  $S_i^*$  and  $S_j^*$  at the outputs of analysis filter bank 21' (Figure 6) each occupy the available bandwidth for a sampling frequency  $F_s$  of about 24 MHz minimum, as illustrated in Figure 10.

10 When the subband signals are upsampled by interpolation unit 24' (Figure 6) the bandwidth of the frequency spectrum of each subband signal is reduced and a series of similar, i.e. duplicate, lobes are produced, each centered on a different frequency, as shown in Figure 11. It should be appreciated that the duplicate lobes shown in Figure 11 would not necessarily be produced in a similar manner for other input signals.

15 Assuming that filter 26' is a Raise-Cosine filter, it removes the higher frequency lobes. As shown in Figure 12, which shows the frequency spectra of the two subband signals  $S_i'$  and  $S_j'$ , after upsampling and filtering, the upsampling rate  $P$  is chosen so as to reduce the frequency spectrum to approximately that of the channel bandwidth  $BW$ , with centre frequency  $fc_2$ . For the QAM example, with  $F_s = 20$  MHz and  $M$  equal to  
 20 4, the upsampling rate  $P$  would be equal to, or greater than  $M$ , i.e. 4. It should be noted that in Figure 12 two spectra are shown, one for  $S_i'$  and one for  $S_j'$ . The spectra overlap and are very similar and, of course, will be transmitted alternately, i.e. time division multiplexed.

It should be noted that centre frequency  $fc_2$  in Figure 12 is not necessarily the  
 25 same as the centre frequency  $fc_1$  (Figure 8) of the input signal  $I$ . In the case of QAM,  $fc_1$  would be the carrier frequency. For other forms of modulation, it might be defined differently. The centre frequency  $fc_2$  shown in Figure 12 can be controlled so that it is centred upon the bandwidth of the transmission channel 14 itself. This can be done by suitable selection of the characteristics of filter 26' (Figure 6).

30 More particularly, filter 26' could be a bandpass filter which would remove lower frequency and higher frequency duplicate lobes.

It should be noted that the system will usually be designed so that the channel bandwidth  $BW_{CH}$  will be approximately the same as the bandwidth  $BW$  of the input

signal I. However, the bandwidth BW of the input signal I will not extend to zero, whereas the bandwidth  $BW_{CH}$  of the channel conceivably could extend to zero.

In the latter case, filter 26' could be selected to produce a baseband output signal matching the channel bandwidth, thereby optimizing utilization of, for example, a twisted  
5 pair subscriber loop.

The filter 26' filters both subband signals  $S_i$  and  $S_j$ , which alternate in the serial data stream leaving the TDM unit 22'. As can be seen from Figure 12, the frequency spectrum of transmitted subband signal  $S_i'$  (shown in broken lines) is similar to, but not identical to, the frequency spectrum of subband signal  $S_j'$ . The two frequency spectra  
10 are shown superimposed because, while they occupy much the same bandwidth, they occur alternately in the time domain. Consequently, the signal bandwidth in the channel varies only slightly during the transmission as a result of fluctuations between  $S_i'$  and  $S_j'$ .

A person skilled in this art will be able to infer the corresponding operation of the decoder, and the signals therein, from the description of the encoder, so they will not  
15 be described here.

Whereas the encoder of Figure 6 upsamples the multiplexed signal, it should be noted that the individual subband signals could be upsampled and interpolated before being multiplexed. However, an advantage of multiplexing before upsampling is that fewer delay banks are needed.

20 Various modifications may be made to the above-described embodiments of the invention without departing from the scope and spirit of the present invention. For example, the analysis filter bank and synthesis filter bank could be like those described in WO 9809383, or other suitable filter bands such as those disclosed by Akansu.

It is not essential for P to be equal to M. Using an upsampling rate P which is  
25 less than downsampling rate M (of the analysis filter bank) could reduce the output sampling frequency and hence the complexity of the D-to-A converter.

An advantage of one embodiment of the present invention is that the encoded signal may be passband or baseband, enabling selection of the particular band according to the particular application.

#### INDUSTRIAL APPLICABILITY

Embodiments of the present invention advantageously simplify the circuitry required to modulate the input digital signal and improve the tolerance of transmitted/stored signal to impulse noise.

## CLAIMS:

1. Apparatus for encoding digital signals for transmission and/or storage and decoding such encoded signals after transmission and/or storage, the apparatus  
5 comprising an encoder and a decoder, the encoder having input means for the digital signal, analysis filter bank means for converting the digital signal into a plurality of subband signals, means for upsampling each of some or all of said subband signals to produce a plurality of upsampled subband signals each having a frequency spectrum in which segments are duplicated, each duplicate having a bandwidth no greater than a  
10 prescribed bandwidth of a transmission channel or storage means, means for selecting one of the duplicates of each of the selected subband signals and multiplexing means for time division multiplexing the selected duplicates to form an encoded signal for transmission or storage, the decoder having decoder input means for downsampling the received encoded signal at a rate that corresponds to that used by the encoder to  
15 upsample the subband signals, demultiplexing means for demultiplexing the downsampled signal to provide a plurality of received subband signals corresponding to said subband signals in the encoder, and synthesis filter bank means complementary to the encoder analysis filter bank means for processing the plurality of received subband signals to form a reconstructed decoded signal corresponding to said digital input signal.  
20
2. Apparatus according to claim 1, wherein the encoder upsampling means upsamples the subband signals following multiplexing by said multiplexing means and the decoder input means downsamples the received signal before demultiplexing by the demultiplexing means.  
25
3. Apparatus according to claim 1 or 2, wherein the upsampling means upsamples at a rate that corresponds to the number of subbands created by the analysis filter bank means.
- 30 4. Apparatus according to claim 1, 2 or 3, wherein the means for time division multiplexing the subband signals comprises delay means for storing a series of values of each subband signal, the delay means being operable alternately between a first state wherein the delay means accepts values of the subband signals in parallel and a second

state wherein the delay means outputs previously stored values serially, and the means for demultiplexing the received signal to extract the subband signals comprises delay means for storing a series of values of said received signal, the delay means being operable alternately between a first state wherein the delay means accepts values of the received signal serially and a second state wherein the delay means outputs previously stored values in parallel as said subband signals.

5. Apparatus according to claim 1, 2 or 3, wherein the means for time division multiplexing the subband signals comprises first delay means and second delay means each for accepting a series of values of each subband signal, each delay means being operable alternately between a first state wherein the delay means accepts values of the subband signals in parallel and a second state wherein the delay means outputs previously stored values serially, the arrangement being such that, when the first delay means is in its first state accepting values of the subband signals, the second delay means is in its second state and outputting the subband signal values previously stored therein, and the means for time division demultiplexing the subband signals comprises first delay means and second delay means each for accepting a series of values of the received signal, each delay means being operable alternately between a first state wherein the delay means accepts values of the received signal serially and a second state wherein the delay means outputs previously stored values in parallel, the arrangement being such that, when the first delay means is in its first state accepting values of the received signal, the second delay means is in its second state and outputting the subband signal values previously stored therein.

6. An encoder for encoding digital signals for transmission and/or storage comprising input means for the digital signal, analysis filter bank means for converting the digital signal into a plurality of subband signals, means for upsampling each of some or all of said subband signals to produce a plurality of upsampled subband signals each having a frequency spectrum in which segments are duplicated, each duplicate having a bandwidth no greater than a prescribed bandwidth of a transmission channel or storage means, means for selecting one of the duplicates of each of the upsampled subband signals, and multiplexing means for time division multiplexing the selected duplicates to form an encoded signal for transmission or storage.

7. An encoder according to claim 6, wherein the encoder upsampling means upsamples the subband signals following multiplexing by the multiplexing means.
8. An encoder according to claim 6 or 7, wherein the upsampling means upsamples  
5 at a rate dependent upon the number of subbands created by the analysis filter bank means.
9. An encoder according to claim 6, 7 or 8, wherein the means for time division multiplexing the subband signals comprises delay means for storing a series of values of  
10 each subband signal, the delay means being operable alternately between a first state wherein the delay means accepts values of the subband signals in parallel and a second state wherein the delay means outputs previously stored values serially.
10. An encoder according to claim 6, 7 or 8, wherein the means for time division  
15 multiplexing the subband signals comprises first delay means and second delay means each for accepting a series of values of each subband signal, each delay means being operable alternately between a first state wherein the delay means accepts values of the subband signals in parallel and a second state wherein the delay means outputs previously stored values serially, the arrangement being such that, when the first delay means is in  
20 its first state accepting values of the subband signals, the second delay means is in its second state and outputting the subband signal values previously stored therein.
11. A decoder for decoding digital signals from an encoder according to claim 6, the decoder having decoder input means for downsampling the received encoded signal at  
25 a rate corresponding to that used by the encoder to upsample the subband signals, demultiplexing means for demultiplexing the downsampled signal to provide a plurality of received subband signals corresponding to said subband signals in the encoder, and a synthesis filter bank for processing the plurality of received subband signals to form a reconstructed decoded signal corresponding to said digital input signal encoded by the  
30 encoder.
12. A decoder according to claim 11, wherein the decoder input means downsamples the received signal before demultiplexing by the demultiplexing means.

13. A decoder according to claim 11 or 12, wherein the decoder input means downsamples at a rate (P) corresponding to the upsampling rate used by the encoder to upsample the subband signals.
- 5 14. A decoder according to claim 11, 12 or 13, wherein the means for demultiplexing the received signal to extract the subband signals comprises delay means for storing a series of values of said received signal, the delay means being operable alternately between a first state wherein the delay means accepts values of the received signal serially and a second state wherein the delay means outputs previously stored values in  
10 parallel as said subband signals.
15. A decoder according to claim 11, 12 or 13, wherein the means for time division demultiplexing the subband signals comprises first delay means and second delay means each for accepting a series of values of the received signal, each delay means being  
15 operable alternately between a first state wherein the delay means accepts values of the received signal serially and a second state wherein the delay means outputs previously stored values in parallel, the arrangement being such that, when the first delay means is in its first state accepting values of the received signal, the second delay means is in its second state and outputting the subband signal values previously stored therein.  
20
16. A method of encoding digital signals for transmission and/or storage and decoding such encoded signals after transmission and/or storage, the encoding comprising the steps of:
- using an analysis filter bank means, converting the digital signal into a plurality  
25 of subband signals;
  - upsampling each of some or all of said subband signals to produce a plurality of upsampled subband signals each having a frequency spectrum in which segments are duplicated, each duplicate having a bandwidth no greater than a prescribed bandwidth of a transmission channel or storage means;
  - 30 selecting one of the duplicates of each of the upsampled subband signals; and
  - time division multiplexing the selected duplicates to form an encoded signal for transmission or storage;
- the decoding including the steps of:

downsampling the received encoded signal at a rate that corresponds to that used by the encoder to upsample the subband signals;

demultiplexing the downsampled signal to provide a plurality of received subband signals corresponding to said subband signals in the encoder; and

5 using a synthesis filter bank means complementary to the analysis filter bank means used during the encoding, processing the plurality of received subband signals to form a reconstructed decoded signal corresponding to said digital input signal.

17. A method according to claim 16, wherein the step of upsampling during encoding  
10 is applied to the multiplexed subband signals and the step of downsampling during decoding is applied to the received signal before demultiplexing.

18. A method according to claim 16 or 17, wherein the upsampling during encoding  
15 is at a rate corresponding to the number of subbands created by the analysis filter bank means.

19. A method according to claim 16, 17 or 18, wherein the time division multiplexing  
the subband signals comprises the steps of alternately storing a series of values of each  
subband signal, in parallel, in delay means and outputting serially from the delay means  
20 values previously stored therein, and the demultiplexing of the received signal to extract  
the subband signals comprises the steps of alternately storing a series of values of said  
received signal serially in delay means and outputting previously stored values in parallel  
as said subband signals.

25 20. A method according to claim 16, 17 or 18, wherein the step of multiplexing the  
subband signals uses first delay means and second delay means each for accepting a  
series of values of each subband signal, each delay means being alternately loaded with  
values of the subband signals in parallel and outputting previously stored values serially,  
the arrangement being such that, during the step of loading each of the delay means with  
30 values of the subband signals, the other delay means is outputting the subband signal  
values previously stored therein, and the step of time division demultiplexing of the  
subband signals uses first delay means and second delay means each for accepting a  
series of values of the received signal, each delay means being alternately loaded with

values of the received signal serially and outputting previously stored values in parallel, the arrangement being such that, when each of the delay means is being loaded with values of the received signal, the other of the delay means is outputting the subband signal values previously stored therein.

5

21. A method of encoding digital signals for transmission and/or storage comprising the steps of, using analysis filter bank means to convert the digital signal into a plurality of subband signals, upsampling each of some or all of said subband signals to produce a plurality of upsampled signals each having a frequency spectrum in which segments are  
10 duplicated, each duplicate having a bandwidth no greater than a prescribed bandwidth of a transmission channel or storage means, selecting one of the duplicates of each of the upsampled subband signals and multiplexing the selected duplicates to form an output signal for transmission or storage.

15 22. An encoding method according to claim 21, wherein the upsampling is performed after the step of multiplexing the subband signals.

23. An encoding method according to claim 21 or 22, wherein the upsampling is at a rate corresponding to the number of subbands provided by the analysis filter bank  
20 means.

24. An encoding method according to claim 21, 22 or 23, wherein the multiplexing of the subband signals uses delay means for storing a series of values of each subband signal, the values being stored in the delay means in parallel and, alternately, previously  
25 stored values outputted from the delay means serially.

25. An encoding method according to claim 21, 22 or 23, wherein the step of multiplexing the subband signals uses first delay means and second delay means each for accepting a series of values of each subband signal, each delay means being loaded with  
30 values of the subband signals in parallel and, alternately, outputting previously stored values serially, the arrangement being such that, during loading of each of the delay means with values of the subband signals, the other delay means is outputting the subband signal values previously stored therein.

26. A method of decoding encoded digital signals encoded by a method according to claim 21, comprising the steps of downsampling the received modulated signal at a rate corresponding to that used during encoding to upsample the subband signals, demultiplexing the downsampled signal to provide a plurality of received subband signals  
5 corresponding to the subband signals produced during encoding, and using a synthesis filter bank to process the plurality of received subband signals to form a reconstructed decoded signal.
27. A decoding method according to claim 26, wherein the received encoded signal  
10 is downsampled before demultiplexing.
28. A decoding method according to claim 26 or 27, wherein the downsampling is at a rate corresponding to the upsampling rate used during encoding.
- 15 29. A decoding method according to claim 26, 27 or 28, wherein the step of demultiplexing the received signal to extract the subband signals comprises the steps of alternately storing a series of values of said received signal serially in delay means, and outputting previously stored values in parallel as said subband signals.
- 20 30. A decoding method according to claim 26, 27 or 28, wherein the step of demultiplexing the subband signals uses first delay means and second delay means each for accepting a series of values of the received signal, each delay means having values of the received signal loaded therein serially and, alternately, outputting previously stored values in parallel, the arrangement being such that, when the values of the received  
25 signal are being loaded into one of the delay means, the subband signal values previously stored in the other delay means are being outputted.

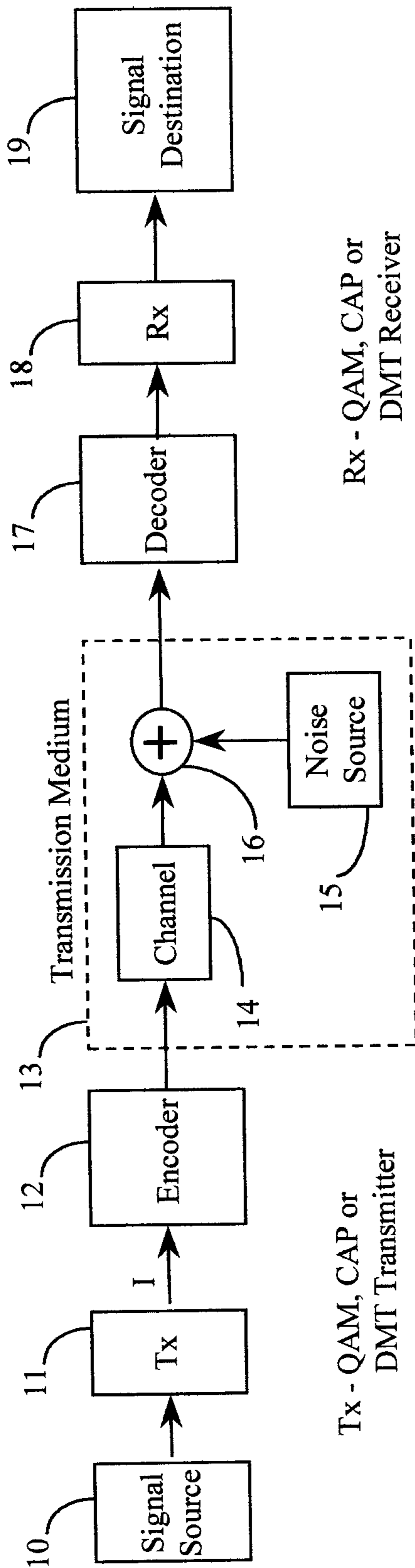

Fig. 1

*Thomas Adams & Assoc.*  
AGENT FOR APPLICANT

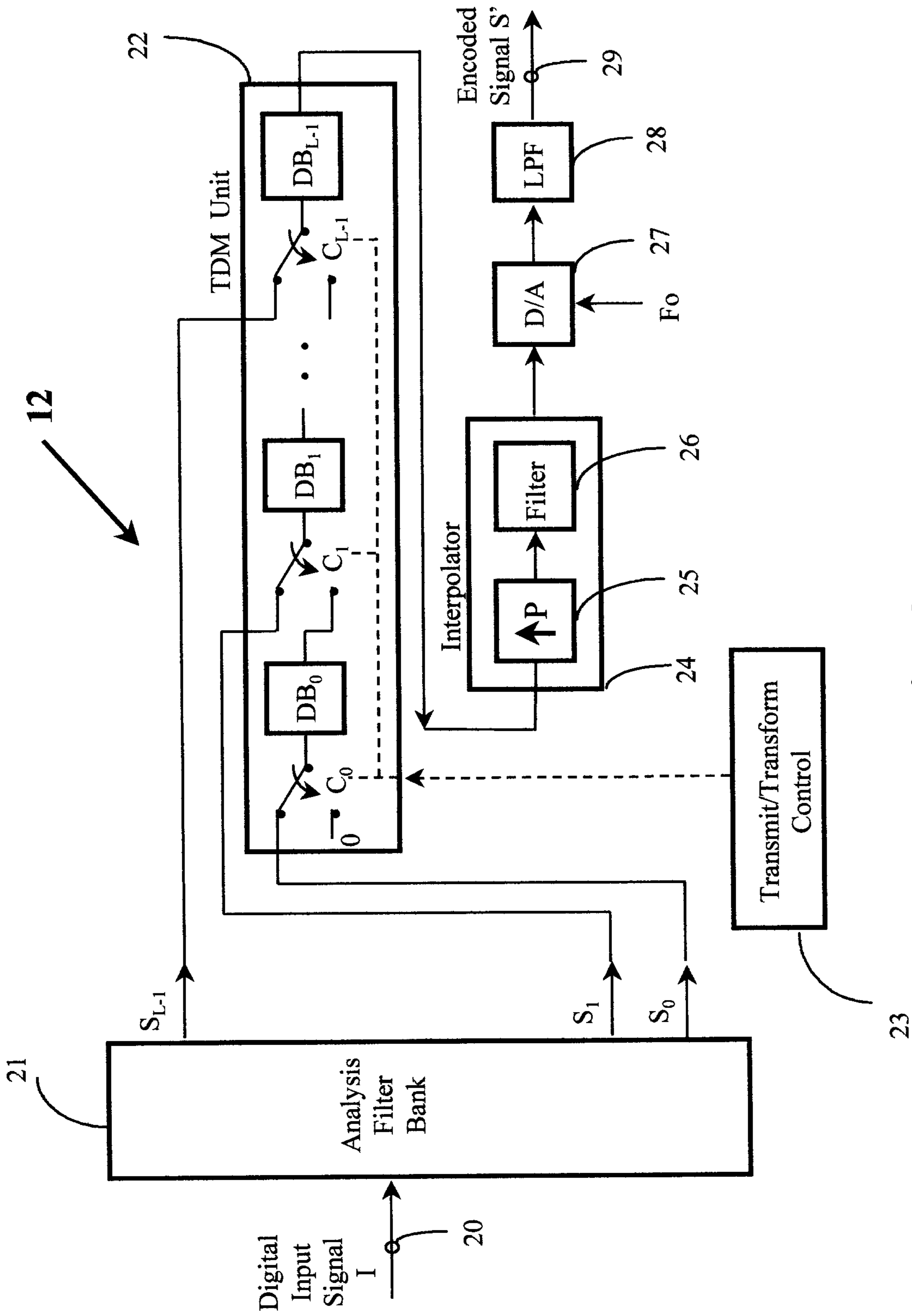

Fig. 2

Thomas Adams & Assoc.  
AGENT FOR APPLICANT

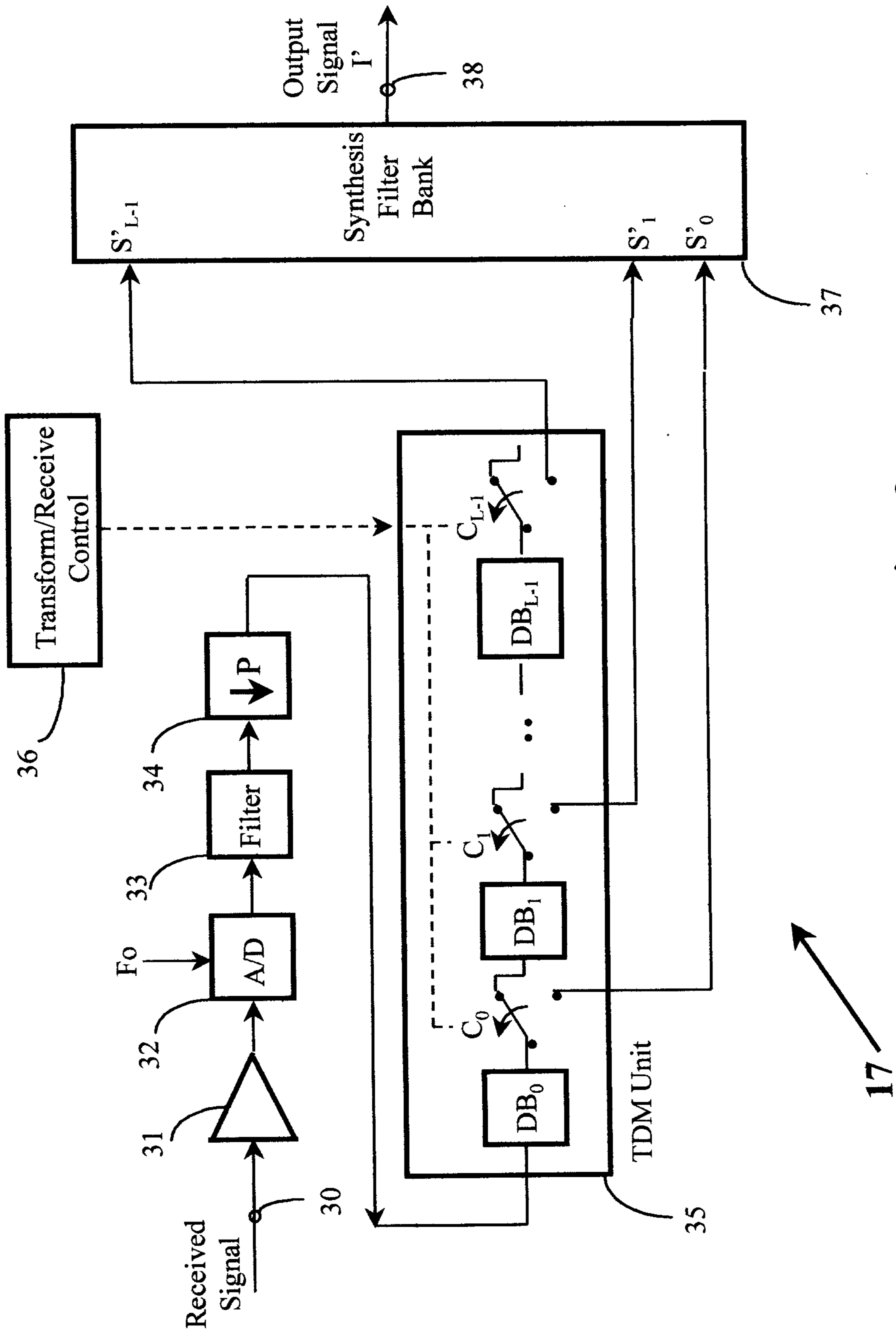

Fig. 3

Thomas Adams & Assoc.  
AGENT FOR APPLICANT

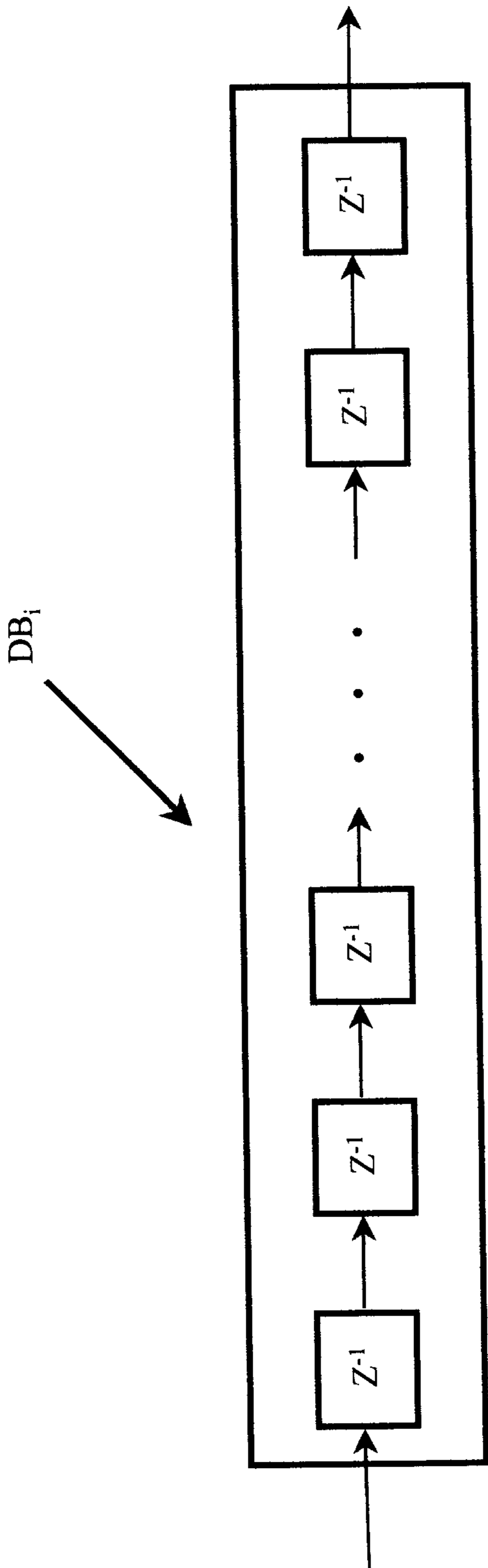

Fig. 4

*Thomas Adams & Assoc.*  
AGENT FOR APPLICANT

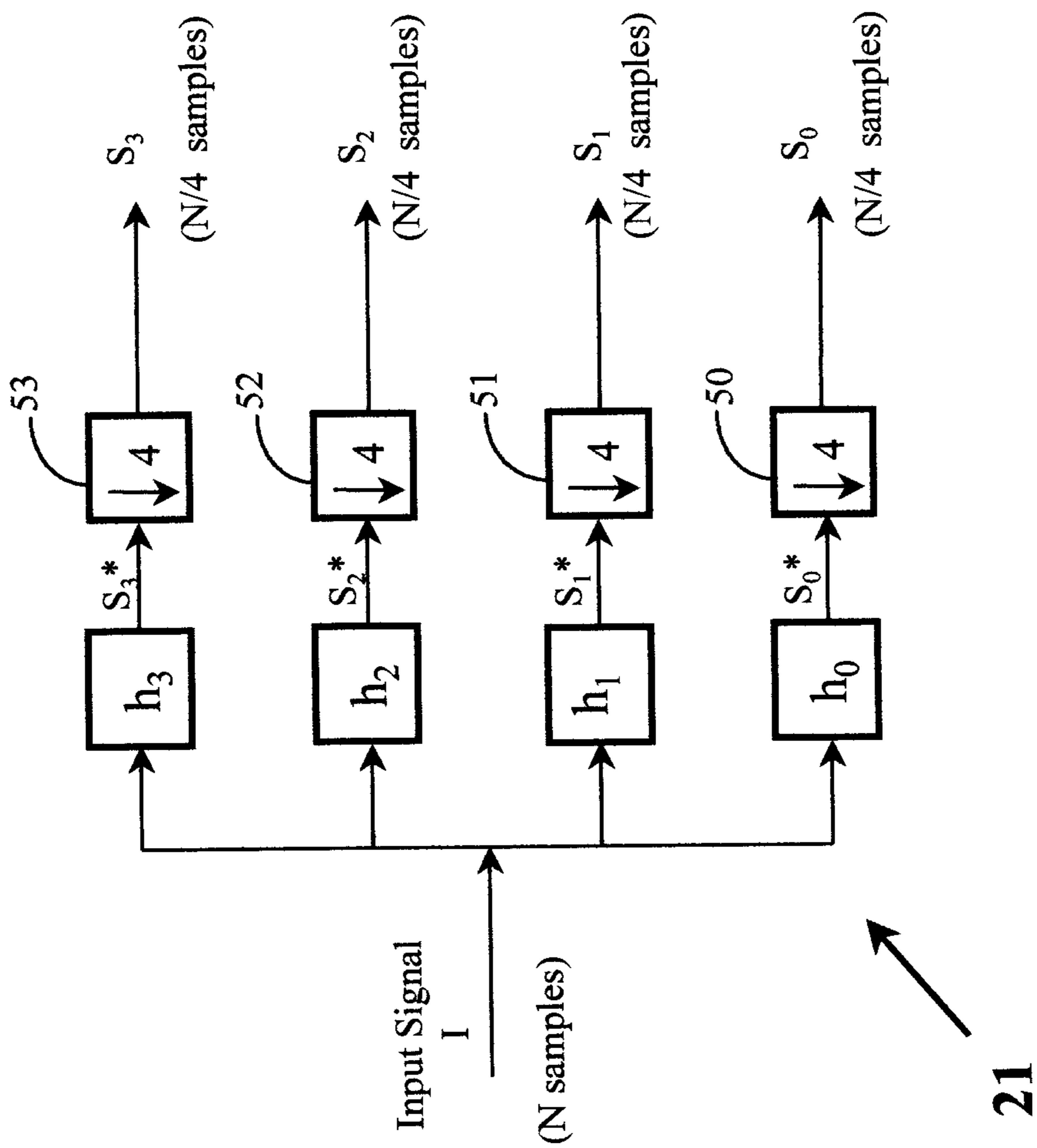

Fig. 5A

Thomas Adams & Assn.  
AGENT FOR APPLICANT

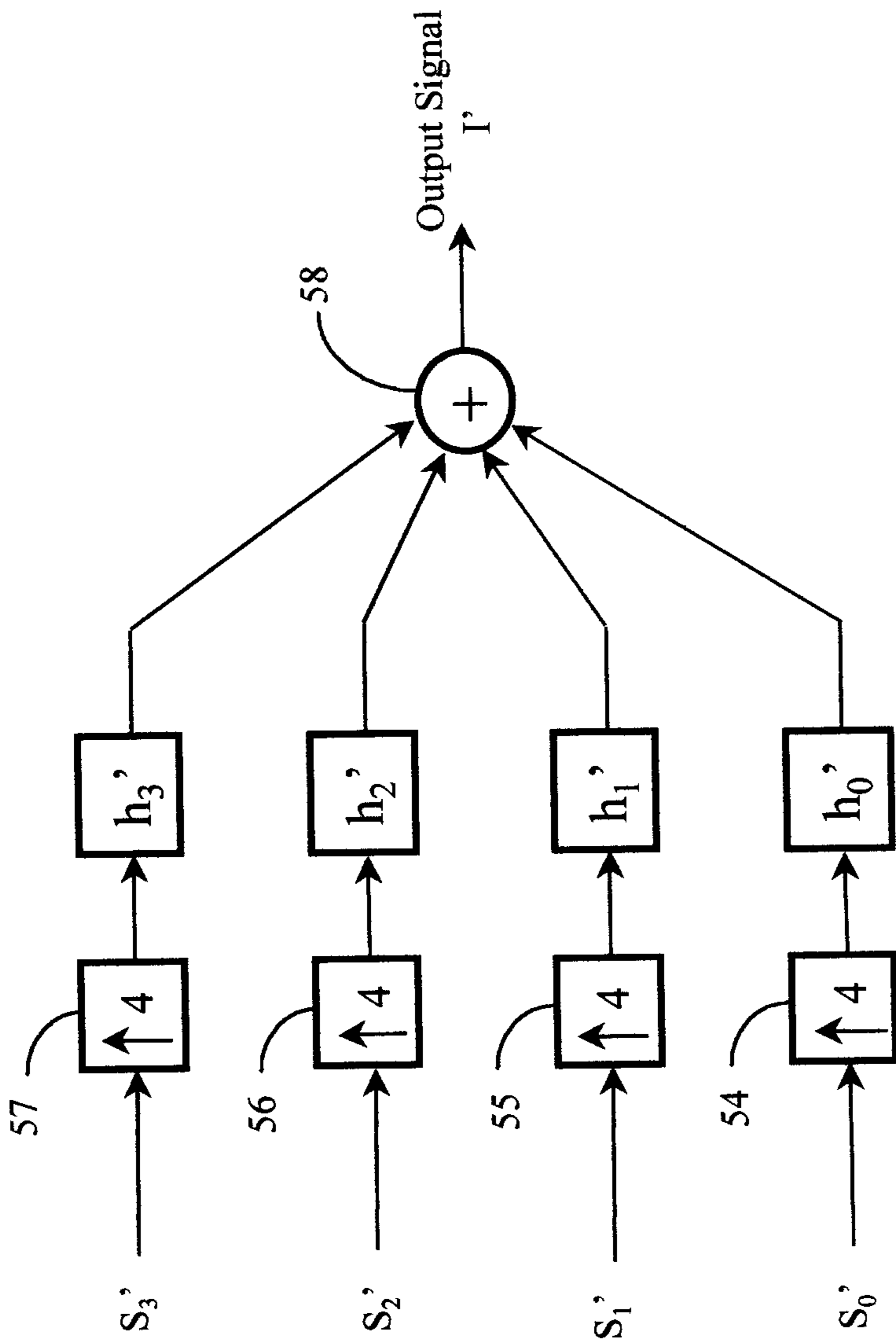

Fig. 5B

37

Thomas Adam & Assoc.  
AGENT FOR APPLICANT

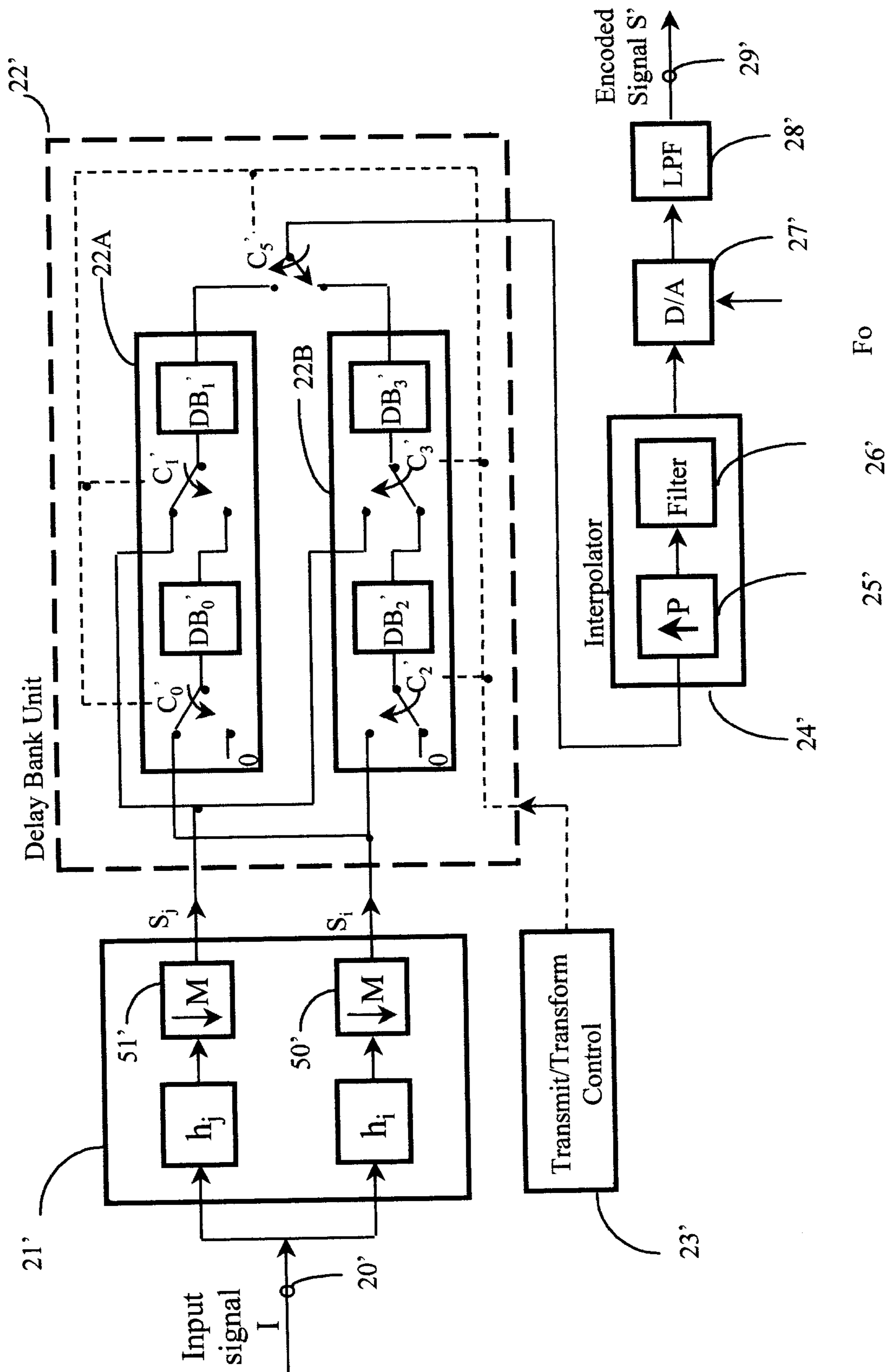

Fig. 6

Thomas Adams Esq.  
AGENT FOR APPLICANT

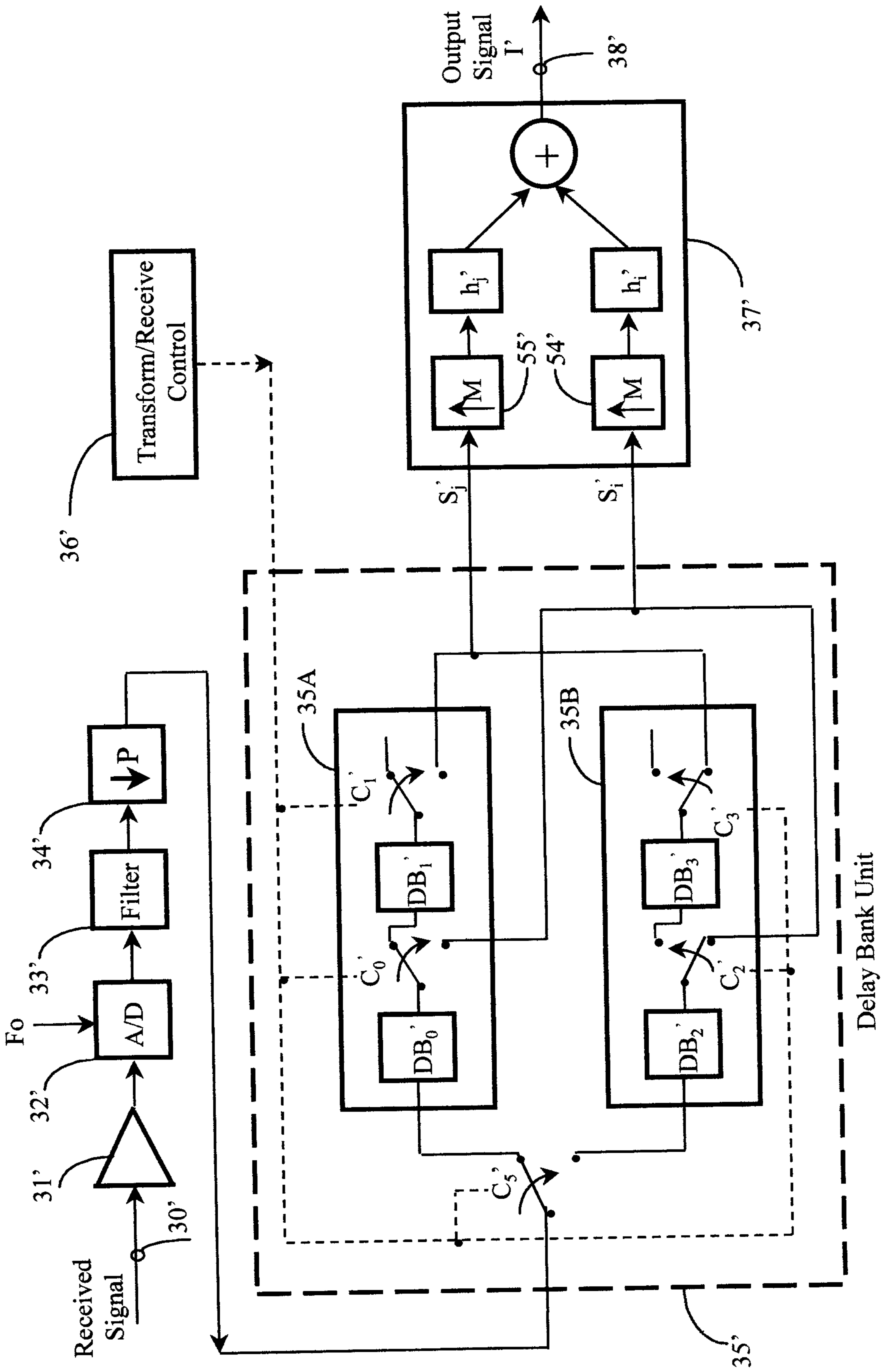

Fig. 7

Thomas Adams & Assn.  
AGENT FOR APPLICANT

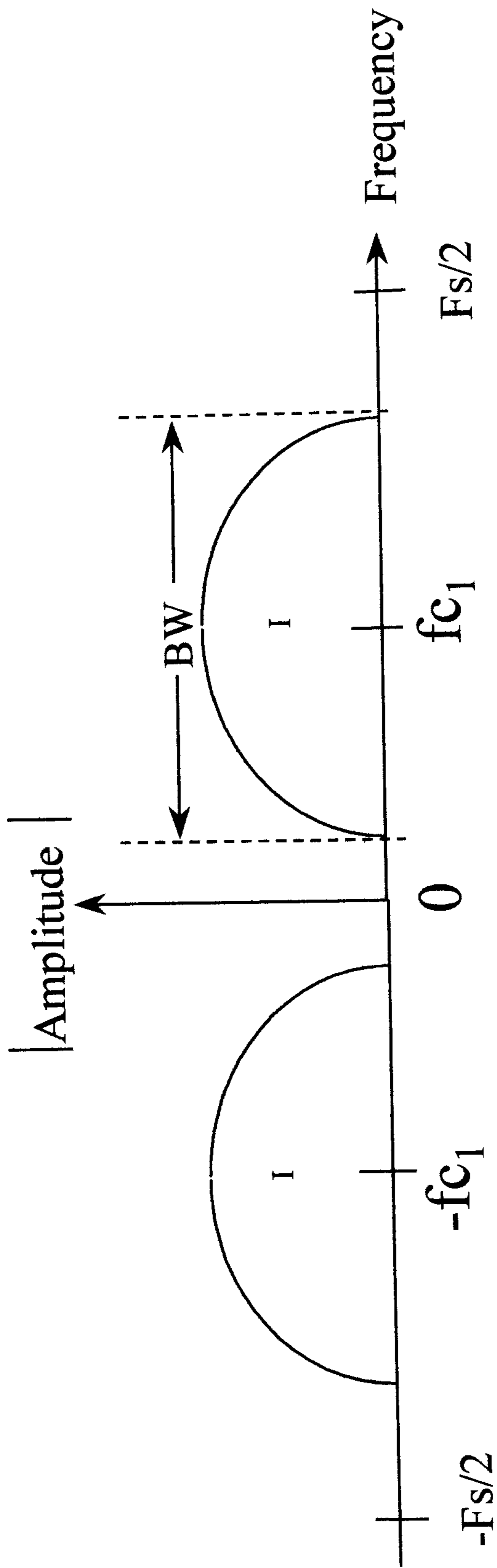

Fig. 8

*Thomas Adams & Assoc.*  
AGENT FOR APPLICANT

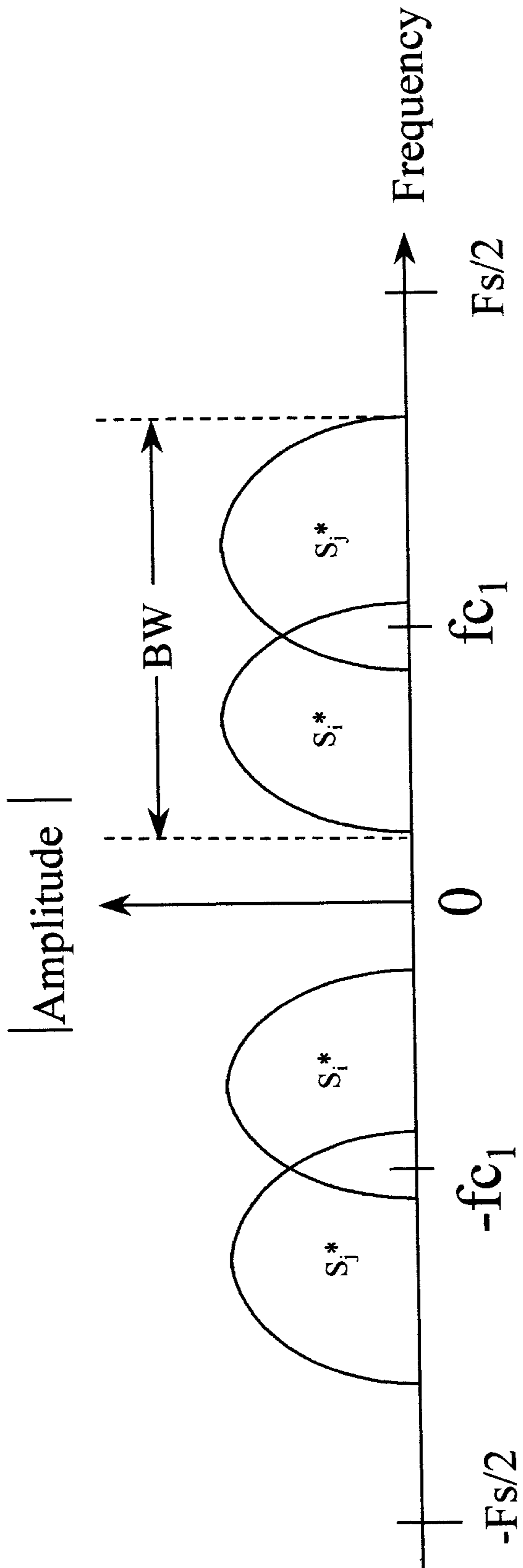

Fig. 9

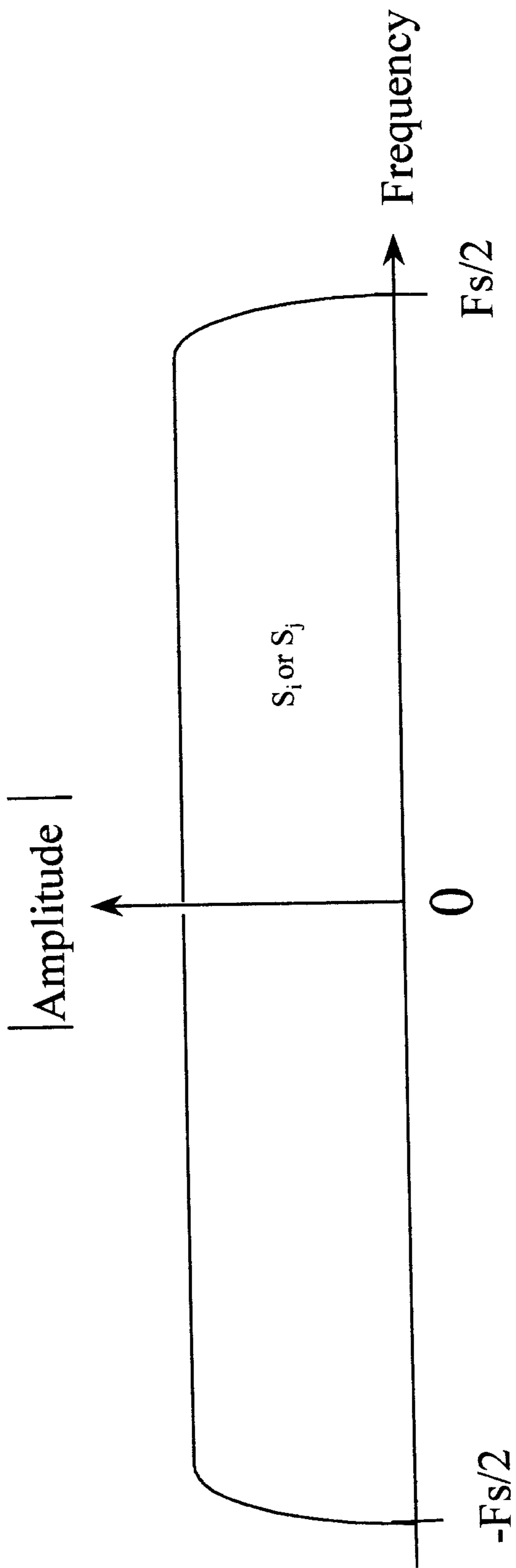

Fig. 10

*Thomas Adams & Assoc*  
AGENT FOR APPLICANT

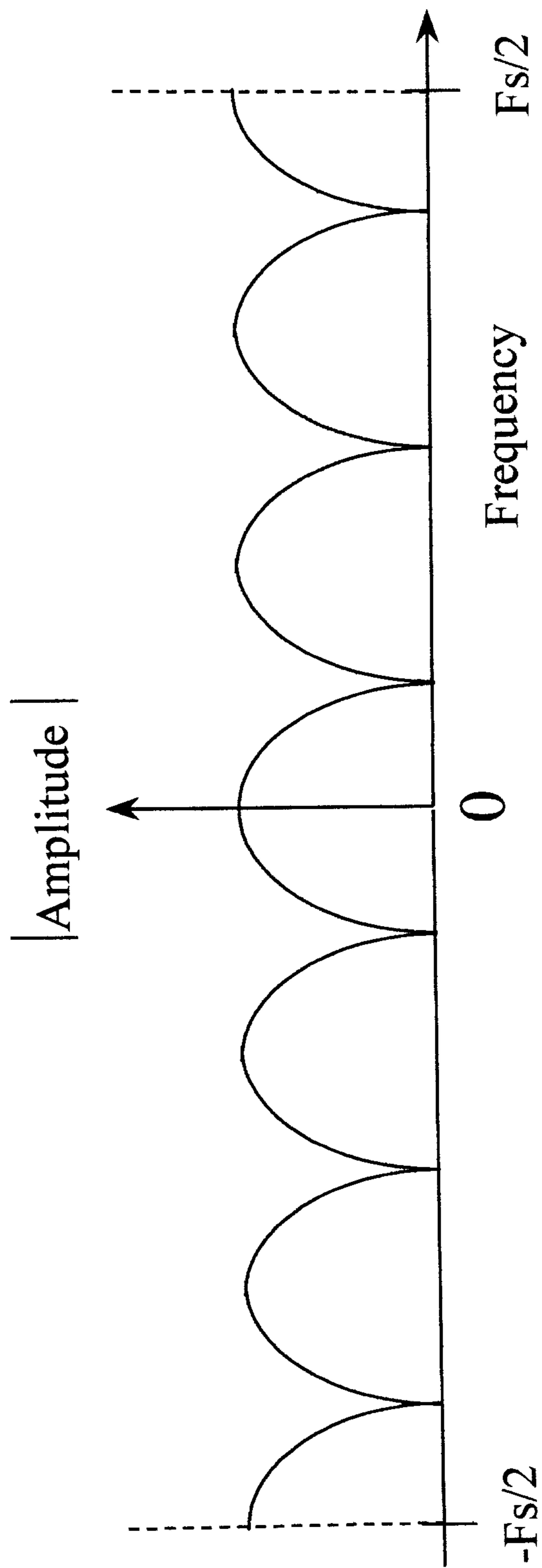

Fig. 11

Thomas Adams & Assoc.  
AGENT FOR APPLICANT

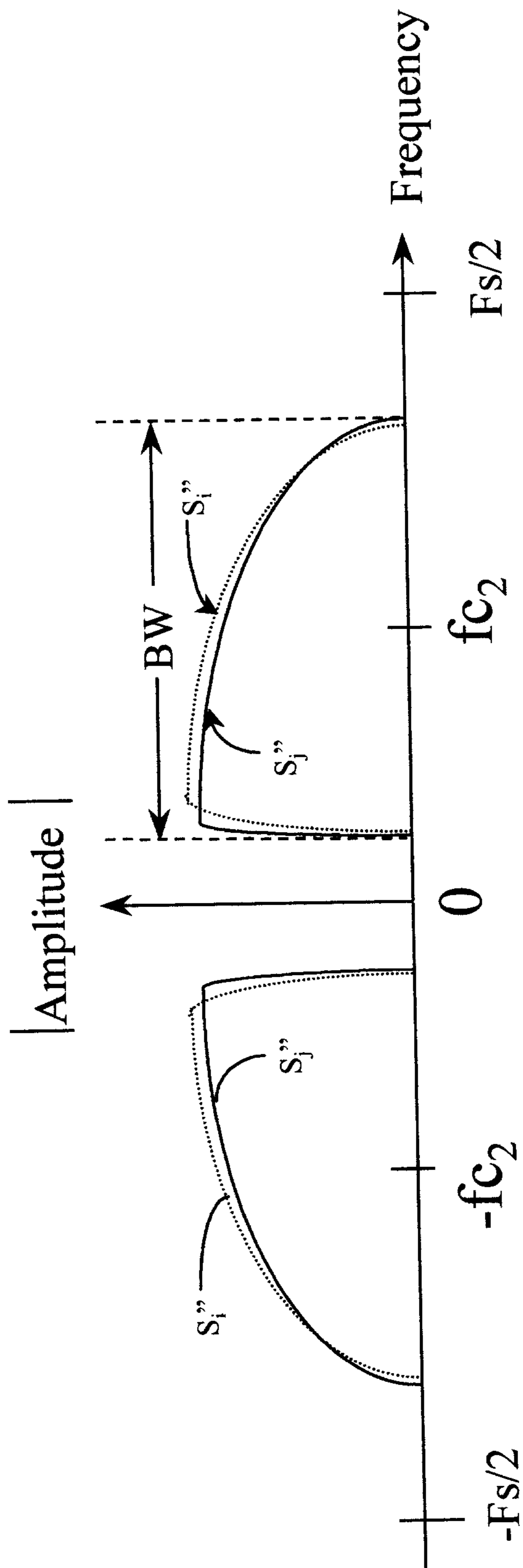

Fig. 12