



- (51) International Patent Classification:
H01L 21/31 (2006.01) *H01L 21/205* (2006.01)
- (21) International Application Number:
PCT/US2013/033174
- (22) International Filing Date:
20 March 2013 (20.03.2013)
- (25) Filing Language: English
- (26) Publication Language: English
- (30) Priority Data:
61/616,377 27 March 2012 (27.03.2012) US
61/737,419 14 December 2012 (14.12.2012) US
13/774,350 22 February 2013 (22.02.2013) US
- (71) Applicant (for all designated States except US): **NOVEL-LUS SYSTEMS, INC.** [US/US]; 4650 Cushing Parkway, Fremont, California 94538 (US).
- (72) Inventors; and
- (71) Applicants (for US only): **CHANDRASHEKAR, Anand** [IN/US]; 1180 Reed Ave., #11, Sunnyvale, California 94086 (US). **JENG, Esther** [US/US]; 1641 Elmhurst Drive, Los Altos, California 94024 (US). **HUMAYUN,**

Raashina [US/US]; 1060 Laureles Drive, Los Altos, California 94022 (US). **DANEK, Michal** [US/US]; 10201 Amelia Court, Cupertino, California 95019 (US). **GAO, Juwen** [CN/US]; 949 Radcliff Drive, San Jose, California 95117 (US). **WANG, Deqi** [CN/US]; 1502 Ambergrove Drive, San Jose, California 95131 (US).

(74) Agents: **BERGIN, Denise, S.** et al.; WEAVER AUSTIN VILLENEUVE & SAMPSON LLP, P.O. Box 70250, Oakland, CA 94612-0250 (US).

(81) Designated States (unless otherwise indicated, for every kind of national protection available): AE, AG, AL, AM, AO, AT, AU, AZ, BA, BB, BG, BH, BN, BR, BW, BY, BZ, CA, CH, CL, CN, CO, CR, CU, CZ, DE, DK, DM, DO, DZ, EC, EE, EG, ES, FI, GB, GD, GE, GH, GM, GT, HN, HR, HU, ID, IL, IN, IS, JP, KE, KG, KM, KN, KP, KR, KZ, LA, LC, LK, LR, LS, LT, LU, LY, MA, MD, ME, MG, MK, MN, MW, MX, MY, MZ, NA, NG, NI, NO, NZ, OM, PA, PE, PG, PH, PL, PT, QA, RO, RS, RU, RW, SC, SD, SE, SG, SK, SL, SM, ST, SV, SY, TH, TJ, TM, TN, TR, TT, TZ, UA, UG, US, UZ, VC, VN, ZA, ZM, ZW.

[Continued on next page]

(54) Title: TUNGSTEN FEATURE FILL WITH NUCLEATION INHIBITION

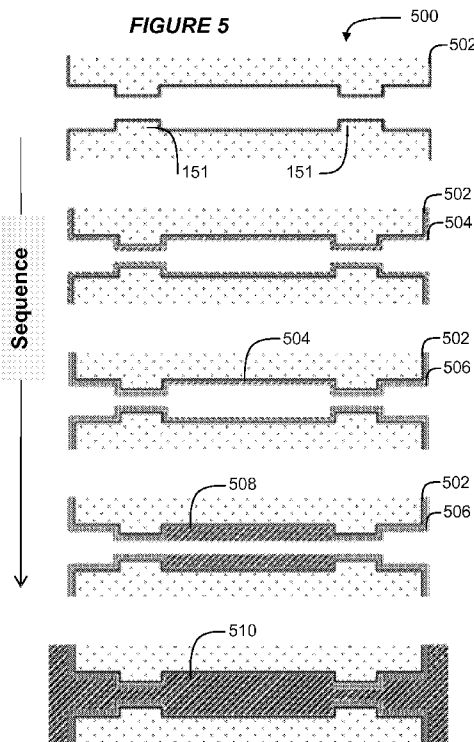

(57) Abstract: Described herein are methods of filling features with tungsten, and related systems and apparatus, involving inhibition of tungsten nucleation. In some embodiments, the methods involve selective inhibition along a feature profile. Methods of selectively inhibiting tungsten nucleation can include exposing the feature to a direct or remote plasma. In certain embodiments, the substrate can be biased during selective inhibition. Process parameters including bias power, exposure time, plasma power, process pressure and plasma chemistry can be used to tune the inhibition profile. The methods described herein can be used to fill vertical features, such as in tungsten vias, and horizontal features, such as vertical NAND (VNAND) wordlines. The methods may be used for both conformal fill and bottom-up/inside-out fill. Examples of applications include logic and memory contact fill, DRAM buried wordline fill, vertically integrated memory gate/wordline fill, and 3-D integration using through-silicon vias.

WO 2013/148444 A1



(84) Designated States (*unless otherwise indicated, for every kind of regional protection available*): ARIPO (BW, GH, GM, KE, LR, LS, MW, MZ, NA, RW, SD, SL, SZ, TZ, UG, ZM, ZW), Eurasian (AM, AZ, BY, KG, KZ, RU, TJ, TM), European (AL, AT, BE, BG, CH, CY, CZ, DE, DK, EE, ES, FI, FR, GB, GR, HR, HU, IE, IS, IT, LT, LU, LV, MC, MK, MT, NL, NO, PL, PT, RO, RS, SE, SI, SK,

SM, TR), OAPI (BF, BJ, CF, CG, CI, CM, GA, GN, GQ, GW, ML, MR, NE, SN, TD, TG).

Published:

— *with international search report (Art. 21(3))*

TUNGSTEN FEATURE FILL WITH NUCLEATION INHIBITION

PRIORITY CLAIM

[0001] This application claims priority to U.S. Provisional Patent Application No. 61/616,377, filed March 27, 2012, U.S. Provisional Patent Application No. 61/737,419, filed December 14, 2012, and U.S. Patent Application No. 13/774,350, filed February 22, 2012. All of these applications are incorporated herein by this reference in their entireties for all purposes.

BACKGROUND

[0002] Deposition of tungsten-containing materials using chemical vapor deposition (CVD) techniques is an integral part of many semiconductor fabrication processes. These materials may be used for horizontal interconnects, vias between adjacent metal layers, contacts between first metal layers and devices on the silicon substrate, and high aspect ratio features. In a conventional deposition process, a substrate is heated to a predetermined process temperature in a deposition chamber, and a thin layer of tungsten-containing materials that serves as a seed or nucleation layer is deposited. Thereafter, the remainder of the tungsten-containing material (the bulk layer) is deposited on the nucleation layer. Conventionally, the tungsten-containing materials are formed by the reduction of tungsten hexafluoride (WF_6) with hydrogen (H_2). Tungsten-containing materials are deposited over an entire exposed surface area of the substrate including features and a field region.

[0003] Depositing tungsten-containing materials into small and, especially, high aspect ratio features may cause formation of seams and voids inside the filled features. Large seams may lead to high resistance, contamination, loss of filled materials, and otherwise degrade performance of integrated circuits. For example, a seam may extend close to the field region after filling process and then open during chemical-mechanical planarization.

SUMMARY

[0004] One aspect described herein is a method involving providing a substrate including a feature having one or more feature openings and a feature interior, selectively inhibiting tungsten nucleation in the feature such that there is a differential inhibition profile along a feature axis; and selectively depositing tungsten in the

feature in accordance with the differential inhibition profile. Methods of selectively inhibiting tungsten nucleation in the feature include exposing the feature to a direct plasma or a remote plasma. In certain embodiments, the substrate can be biased during selective inhibition. Process parameters including bias power, exposure time, plasma power, process pressure and plasma chemistry can be used to tune the inhibition profile. According to various embodiments, the plasma can contain activated species that interact with a portion the feature surface to inhibit subsequent tungsten nucleation. Examples of activated species include nitrogen, hydrogen, oxygen, and carbon activated species. In some embodiments, the plasma is nitrogen and/or hydrogen-based.

[0005] In some embodiments, a tungsten layer is deposited in the feature prior to any selective inhibition of tungsten nucleation. In other embodiments, selective inhibition is performed prior to any tungsten deposition in the feature. If deposited, a tungsten layer may be deposited conformally, in some embodiments, for example by a pulsed nucleation layer (PNL) or atomic layer deposition (ALD) process. Selective deposition of tungsten in the feature can be performed by a chemical vapor deposition (CVD) process.

[0006] After selectively depositing tungsten in the feature, tungsten can be deposited in the feature to complete feature fill. According to various embodiments, this can involve non-selective deposition in the feature or one or more additional cycles of selective inhibition and selective deposition. In some embodiments, transitioning from selective to non-selective deposition involve allowing a CVD process to continue without deposition of an intervening tungsten nucleation layer. In some embodiments, a tungsten nucleation layer can be deposited on the selectively deposited tungsten, e.g., by a PNL or ALD process, prior to non-selective deposition in the feature.

[0007] According to various embodiments, selectively inhibiting tungsten nucleation can involve treating a tungsten (W) surface, or a barrier or liner layer, such as a tungsten nitride (WN) or titanium nitride (TiN) layer. Selective inhibition can be performed with or without simultaneous etching material in the feature. According to various embodiments, at least a constriction in the feature is selectively inhibited.

[0008] Another aspect of the invention relates to a method include exposing a feature to an in-situ plasma to selectively inhibit a portion of the feature. According to various embodiments, the plasma can be nitrogen-based, hydrogen-based, oxygen-based, or hydrocarbon-based. In some embodiments, the plasma can contain a mixture of two or more of a nitrogen-containing, hydrogen-containing, oxygen-containing, or hydrocarbon-containing gas. For example, an unfilled or partially filled feature may be exposed to a direct plasma to thereby selectively inhibit tungsten nucleation of a portion of the feature such that there is a differential inhibition profile in the feature. In some embodiments, after selectively inhibiting a portion of the feature, performing a CVD operation to thereby selectively deposit tungsten in accordance with the differential inhibition profile.

[0009] Another aspect of the invention relates to single and multi-chamber apparatus configured for feature fill using selective inhibition. In some embodiments, an apparatus includes one or more chambers configured to support a substrate; an in situ plasma generator configured to generate a plasma in one or more of the chambers; gas inlets configured to direct gas into each of the one or more chambers; and a controller having program instructions for generating a plasma such as a nitrogen-based and/or hydrogen-based plasma while applying a bias power to the substrate such that the substrate is exposed to the plasma, after exposing the substrate to the plasma, inletting a tungsten-containing precursor and a reducing agent to a chamber in which the substrate sits to deposit tungsten.

[0010] These and other aspects are described further below.

BRIEF DESCRIPTION OF DRAWINGS

[0011] Figures 1A-1G show examples of various structures that can be filled according to the processes described herein.

[0012] Figures 2-4 are process flow diagrams illustrating certain operations in methods of filling features with tungsten.

[0013] Figures 5-7 are schematic diagrams showing features at various stages of feature fill.

[0014] Figures 8-9B are schematic diagrams showing examples of apparatus suitable for practicing the methods described herein.

DETAILED DESCRIPTION OF EXAMPLE EMBODIMENTS

[0015] In the following description, numerous specific details are set forth in order to provide a thorough understanding of the present invention. The present invention may be practiced without some or all of these specific details. In other instances, well known process operations have not been described in detail to not unnecessarily obscure the present invention. While the invention will be described in conjunction with the specific embodiments, it will be understood that it is not intended to limit the invention to the embodiments.

[0016] Described herein are methods of filling features with tungsten and related systems and apparatus. Examples of application include logic and memory contact fill, DRAM buried wordline fill, vertically integrated memory gate/wordline fill, and 3-D integration with through-silicon vias (TSVs). The methods described herein can be used to fill vertical features, such as in tungsten vias, and horizontal features, such as vertical NAND (VNAND) wordlines. The methods may be used for conformal and bottom-up or inside-out fill.

[0017] According to various embodiments, the features can be characterized by one or more of narrow and/or re-entrant openings, constrictions within the feature, and high aspect ratios. Examples of features that can be filled are depicted in Figures 1A–1C. Figure 1A shows an example of a cross-sectional depiction of a vertical feature 101 to be filled with tungsten. The feature can include a feature hole 105 in a substrate 103. The substrate may be a silicon wafer, e.g., 200-mm wafer, 300-mm wafer, 450-mm wafer, including wafers having one or more layers of material such as dielectric, conducting, or semi-conducting material deposited thereon. In some embodiments, the feature hole 105 may have an aspect ratio of at least about 2:1, at least about 4:1, at least about 6:1 or higher. The feature hole 105 may also have a dimension near the opening, e.g., an opening diameter or line width, of between about 10 nm to 500 nm, for example between about 25 nm to 300 nm. The feature hole 105 can be referred to as an unfilled feature or simply a feature. The feature, and any feature, may be characterized in part by an axis 118 that extends through the length of the feature, with vertically-oriented features having vertical axes and horizontally-oriented features having horizontal axes.

[0018] Figure 1B shows an example of a feature 101 that has a re-entrant profile. A re-entrant profile is a profile that narrows from a bottom, closed end, or interior of the feature to the feature opening. According to various embodiments, the profile may narrow gradually and/or include an overhang at the feature opening. Figure 1B shows an example of the latter, with an under-layer 113 lining the sidewall or interior surfaces of the feature hole 105. The under-layer 113 can be for example, a diffusion barrier layer, an adhesion layer, a nucleation layer, a combination of thereof, or any other applicable material. The under-layer 113 forms an overhang 115 such that the under-layer 113 is thicker near the opening of the feature 101 than inside the feature 101.

[0019] In some embodiments, features having one or more constrictions within the feature may be filled. Figure 1C shows examples of views of various filled features having constrictions. Each of the examples (a), (b) and (c) in Figure 1C includes a constriction 109 at a midpoint within the feature. The constriction 109 can be, for example, between about 15 nm–20 nm wide. Constrictions can cause pinch off during deposition of tungsten in the feature using conventional techniques, with deposited tungsten blocking further deposition past the constriction before that portion of the feature is filled, resulting in voids in the feature. Example (b) further includes a liner/barrier overhang 115 at the feature opening. Such an overhang could also be a potential pinch-off point. Example (c) includes a constriction 112 further away from the field region than the overhang 115 in example (b). As described further below, methods described herein allow void-free fill as depicted in Figure 1C.

[0020] Horizontal features, such as in 3-D memory structures, can also be filled. Figure 1D shows an example of a word line 150 in a VNAND structure 148 that includes a constriction 151. In some embodiments, the constrictions can be due to the presence of pillars in a VNAND or other structure. Figure 1E, for example, shows a plan view of pillars 125 in a VNAND structure, with Figure 1F showing a simplified schematic of a cross-sectional depiction of the pillars 125. Arrows in Figure 1E represent deposition material; as pillars 125 are disposed between an area 127 and a gas inlet or other deposition source, adjacent pillars can result in constrictions that present challenges in void free fill of an area 127.

[0021] Figure 1G provides another example of a view horizontal feature, for example, of a VNAND or other structure including pillar constrictions 151. The

example in Figure 1G is open-ended, with material to be deposited able to enter laterally from two sides as indicated by the arrows. (It should be noted that example in Figure 1G can be seen as a 2-D rendering 3-D features of the structure, with the Figure 1G being a cross-sectional depiction of an area to be filled and pillar constrictions shown in the figure representing constrictions that would be seen in a plan rather than cross-sectional view.) In some embodiments, 3-D structures can be characterized with the area to be filled extending along three dimensions (e.g., in the X, Y and Z-directions in the example of Figure 1F), and can present more challenges for fill than filling holes or trenches that extend along one or two dimensions. For example, controlling fill of a 3-D structure can be challenging as deposition gasses may enter a feature from multiple dimensions.

[0022] Filling features with tungsten-containing materials may cause formation of voids and seams inside the filled features. A void is region in the feature that is left unfilled. A void can form, for example, when the deposited material forms a pinch point within the feature, sealing off an unfilled space within the feature preventing reactant entry and deposition.

[0023] There are multiple potential causes for void and seam formation. One is an overhang formed near the feature opening during deposition of tungsten-containing materials or, more typically, other materials, such as a diffusion barrier layer or a nucleation layer. An example is shown in Figure 1B.

[0024] Another cause of void or seam formation that is not illustrated in Figure 1B but that nevertheless may lead to seam formation or enlarging seams is curved (or bowed) side walls of feature holes, which are also referred to as bowed features. In a bowed feature the cross-sectional dimension of the cavity near the opening is smaller than that inside the feature. Effects of these narrower openings in the bowed features are somewhat similar to the overhang problem described above. Constrictions within a feature such as shown in Figures 1C, 1D and 1G also present challenges for tungsten fill without few or no voids and seams.

[0025] Even if void free fill is achieved, tungsten in the feature may contain a seam running through the axis or middle of the via, trench, line or other feature. This is because tungsten growth can begin at the sidewall and continues until the grains meet with tungsten growing from the opposite sidewall. This seam can allow for

trapping of impurities including fluorine-containing compounds such as hydrofluoric acid (HF). During chemical mechanical planarization (CMP), coring can also propagate from the seam. According to various embodiments, the methods described herein can reduce or eliminate void and seam formation. The methods described herein may also address one or more of the following:

[0026] 1) Very challenging profiles: Void free fill can be achieved in most re-entrant features using dep-etch-dep cycles as described in U.S. Patent Application No. 13/351,970, incorporated by reference herein. However, depending on the dimensions and geometry, multiple dep-etch cycles may be needed to achieve void-free fill. This can affect process stability and throughput. Embodiments described herein can provide feature fill with fewer or no dep-etch-dep cycles.

[0027] 2) Small features and liner/barrier impact: In cases where the feature sizes are extremely small, tuning the etch process without impacting the integrity of the underlayer liner/barrier can be very difficult. In some cases intermittent Ti attack - possibly due to formation of a passivating TiFx layer during the etch - can occur during a W-selective etch.

[0028] 3) Scattering at W grain boundaries: Presence of multiple W grains inside the feature can result in electron loss due to grain boundary scattering. As a result, actual device performance will be degraded compared to theoretical predictions and blanket wafer results.

[0029] 4) Reduced via volume for W fill: Especially in smaller and newer features, a significant part of the metal contact is used up by the W barrier (TiN, WN etc.). These films are typically higher resistivity than W and negatively impact electrical characteristics like contact resistance etc.

[0030] Figures 2-4 provide overviews of various processes of tungsten feature fill that can address the above issues, with examples of tungsten fill of various features described with reference to Figures 5-7.

[0031] Figure 2 is a process flow diagram illustrating certain operations in a method of filling a feature with tungsten. The method begins at a block 201 with selective inhibition of a feature. Selective inhibition, which may also be referred to as selective passivation, differential inhibition, or differential passivation, involves inhibiting subsequent tungsten nucleation on a portion of the feature, while not

inhibiting nucleation (or inhibiting nucleation to a lesser extent) on the remainder of the feature. For example, in some embodiments, a feature is selectively inhibited at a feature opening, while nucleation inside the feature is not inhibited. Selective inhibition is described further below, and can involve, for example, selectively exposing a portion of the feature to activated species of a plasma. In certain embodiments, for example, a feature opening is selectively exposed to a plasma generated from molecular nitrogen gas. As discussed further below, a desired inhibition profile in a feature can be formed by appropriately selecting one or more of inhibition chemistry, substrate bias power, plasma power, process pressure, exposure time, and other process parameters.

[0032] Once the feature is selectively inhibited, the method can continue at block 203 with selective deposition of tungsten according to the inhibition profile. Block 203 may involve one or more chemical vapor deposition (CVD) and/or atomic layer deposition (ALD) processes, including thermal, plasma-enhanced CVD and/or ALD processes. The deposition is selective in that the tungsten preferentially grows on the lesser- and non-inhibited portions of the feature. In some embodiments, block 203 involves selectively depositing tungsten in a bottom or interior portion of the feature until a constriction is reached or passed.

[0033] After selective deposition according to the inhibition profile is performed, the method can continue at block 205 with filling the rest of the feature. In certain embodiments, block 205 involves a CVD process in which a tungsten-containing precursor is reduced by hydrogen to deposit tungsten. While tungsten hexafluoride (WF_6) is often used, the process may be performed with other tungsten precursors, including, but not limited to, tungsten hexachloride (WCl_6), organo-metallic precursors, and precursors that are free of fluorine such as MDNOW (methylcyclopentadienyl-dicarbonylnitrosyl-tungsten) and EDNOW (ethylcyclopentadienyl-dicarbonylnitrosyl-tungsten). In addition, while hydrogen can be used as the reducing agent in the CVD deposition, other reducing agents including silane may be used in addition or instead of hydrogen. In another embodiment, tungsten hexacarbonyl ($W(CO)_6$) may be used with or without a reducing agent. Unlike with ALD and pulsed nucleation layer (PNL) processes described further below, in a CVD technique, the WF_6 and H_2 or other reactants are simultaneously introduced into the reaction chamber. This produces a continuous chemical reaction

of mix reactant gases that continuously forms tungsten film on the substrate surface. Methods of depositing tungsten films using CVD are described in U.S. Patent Application NoS. 12/202,126, 12/755,248 and 12/755,259, which are incorporated by reference herein in their entireties for the purposes of describing tungsten deposition processes. According to various embodiments, the methods described herein are not limited to a particular method of filling a feature but may include any appropriate deposition technique.

[0034] In some embodiments, block 205 may involve continuing a CVD deposition process started at block 203. Such a CVD process may result in deposition on the inhibited portions of the feature, with nucleation occurring more slowly than on the non-inhibited portions of the feature. In some embodiments, block 205 may involve deposition of a tungsten nucleation layer over at least the inhibited portions of the feature.

[0035] According to various embodiments, the feature surface that is selectively inhibited can be a barrier or liner layer, such as a metal nitride layer, or it can be a layer deposited to promote nucleation of tungsten. Figure 3 shows an example of a method in which a tungsten nucleation layer is deposited in the feature prior to selective inhibition. The method begins at block 301 with deposition of the thin conformal layer of tungsten in the feature. The layer can facilitate subsequent deposition of bulk tungsten-containing material thereon. In certain embodiments, the nucleation layer is deposited using a PNL technique. In a PNL technique, pulses of a reducing agent, purge gases, and tungsten-containing precursor can be sequentially injected into and purged from the reaction chamber. The process is repeated in a cyclical fashion until the desired thickness is achieved. PNL broadly embodies any cyclical process of sequentially adding reactants for reaction on a semiconductor substrate, including ALD techniques. PNL techniques for depositing tungsten nucleation layers are described in U.S. Patents 6,635,965; 7,589,017; 7,141,494; 7,772,114; 8,058,170 and in US Patent Application Nos. 12/755,248 and 12/755,259, which are incorporated by reference herein in their entireties for the purposes of describing tungsten deposition processes. Block 301 is not limited to a particular method of tungsten nucleation layer deposition, but includes PNL, ALD, CVD, and physical vapor deposition (PVD) techniques for depositing a thin conformal layer. The nucleation layer can be sufficiently thick to fully cover the feature to support high

quality bulk deposition; however, because the resistivity of the nucleation layer is higher than that of the bulk layer, the thickness of the nucleation layer may be minimized to keep the total resistance as low as possible. Example thicknesses of films deposited in block 301 can range from less than 10 Å to 100 Å. After deposition of the thin conformal layer of tungsten in block 301, the method can continue with blocks 201, 203, and 205 as described above with reference to Figure 2. An example of filling a feature according to a method of Figure 3 is described below with reference to Figure 5.

[0036] Figure 4 shows an example of a method in which completing filling the feature (e.g., block 205 in Figure 2 or 3) can involve repeating selective inhibition and deposition operations. The method can begin at block 201, as described above with respect to Figure 2, in which the feature is selectively inhibited, and continue at block 203 with selective deposition according to the inhibition profile. Blocks 201 and 203 are then repeated one or more times (block 401) to complete feature fill. An example of filling a feature according to a method of Figure 4 is described below with reference to Figure 6.

[0037] Still further, selective inhibition can be used in conjunction with selective deposition. Selective deposition techniques are described in U.S. Provisional Patent Application No. 61/616,377, referenced above.

[0038] According to various embodiments, selective inhibition can involve exposure to activated species that passivate the feature surfaces. For example, in certain embodiments, a tungsten (W) surface can be passivated by exposure to a nitrogen-based or hydrogen-based plasma. In some embodiments, inhibition can involve a chemical reaction between activated species and the feature surface to form a thin layer of a compound material such as tungsten nitride (WN) or tungsten carbide (WC). In some embodiments, inhibition can involve a surface effect such as adsorption that passivates the surface without forming a layer of a compound material. Activated species may be formed by any appropriate method including by plasma generation and/or exposure to ultraviolet (UV) radiation. In some embodiments, the substrate including the feature is exposed to a plasma generated from one or more gases fed into the chamber in which the substrate sits. In some embodiments, one or more gases may be fed into a remote plasma generator, with activated species formed in the remote plasma generator fed into a chamber in which the substrate sits. The

plasma source can be any type of source including radio frequency (RF) plasma source or microwave source. The plasma can be inductively and/or capacitively-coupled. Activated species can include atomic species, radical species, and ionic species. In certain embodiments, exposure to a remotely-generated plasma includes exposure to radical and atomized species, with substantially no ionic species present in the plasma such that the inhibition process is not ion-mediated. In other embodiments, ion species may be present in a remotely-generated plasma. In certain embodiments, exposure to an in-situ plasma involves ion-mediated inhibition. For the purposes of this application, activated species are distinguished from recombined species and from the gases initially fed into a plasma generator.

[0039] Inhibition chemistries can be tailored to the surface that will be subsequently exposed to deposition gases. For tungsten (W) surfaces, as formed for example in a method described with reference to Figure 3, exposure to nitrogen-based and/or hydrogen-based plasmas inhibits subsequent tungsten deposition on the W surfaces. Other chemistries that may be used for inhibition of tungsten surfaces include oxygen-based plasmas and hydrocarbon-based plasmas. For example, molecular oxygen or methane may be introduced to a plasma generator.

[0040] As used herein, a nitrogen-based plasma is a plasma in which the main non-inert component is nitrogen. An inert component such as argon, xenon, or krypton may be used as a carrier gas. In some embodiments, no other non-inert components are present in the gas from which the plasma is generated except in trace amounts. In some embodiments, inhibition chemistries may be nitrogen-containing, hydrogen-containing, oxygen-containing, and/or carbon-containing, with one or more additional reactive species present in the plasma. For example, U.S. Patent Application No. 13/016,656, incorporated by reference herein, describes passivation of a tungsten surface by exposure to nitrogen trifluoride (NF₃). Similarly, fluorocarbons such as CF₄ or C₂F₈ may be used. However, in certain embodiments, the inhibition species are fluorine-free to prevent etching during selective inhibition.

[0041] In certain embodiments, UV radiation may be used in addition to or instead of plasma to provide activated species. Gases may be exposed to UV light upstream of and/or inside a reaction chamber in which the substrate sits. Moreover, in certain embodiments, non-plasma, non-UV, thermal inhibition processes may be used. In addition to tungsten surfaces, nucleation may be inhibited on liner/barrier layers

surfaces such as TiN and/or WN surfaces. Any chemistry that passivates these surfaces may be used. For TiN and WN, this can include exposure to nitrogen-based or nitrogen-containing chemistries. In certain embodiments, the chemistries described above for W may also be employed for TiN, WN, or other liner layer surfaces.

[0042] Tuning an inhibition profile can involve appropriately controlling an inhibition chemistry, substrate bias power, plasma power, process pressure, exposure time, and other process parameters. For in situ plasma processes (or other processes in which ionic species are present), a bias can be applied to the substrate. Substrate bias can, in some embodiments, significantly affect an inhibition profile, with increasing bias power resulting in active species deeper within the feature. For example, 100 W DC bias on a 300 mm substrate may result inhibition the top half of a 1500 nm deep structure, while a 700 W bias may result in inhibition of the entire structure. The absolute bias power appropriate a particular selective inhibition will depend on the substrate size, the system, plasma type, and other process parameters, as well as the desired inhibition profile, however, bias power can be used to tune top-to-bottom selectivity, with decreasing bias power resulting in higher selectivity. For 3-D structures in which selectivity is desired in a lateral direction (tungsten deposition preferred in the interior of the structure), but not in a vertical direction, increased bias power can be used to promote top-to-bottom deposition uniformity.

[0043] While bias power can be used in certain embodiments as the primary or only knob to tune an inhibition profile for ionic species, in certain situations, other performing selective inhibition uses other parameters in addition to or instead of bias power. These include remotely generated non-ionic plasma processes and non-plasma processes. Also, in many systems, a substrate bias can be easily applied to tune selectivity in vertical but not lateral direction. Accordingly, for 3-D structures in which lateral selectivity is desired, parameters other than bias may be controlled, as described above.

[0044] Inhibition chemistry can also be used to tune an inhibition profile, with different ratios of active inhibiting species used. For example, for inhibition of W surfaces, nitrogen may have a stronger inhibiting effect than hydrogen; adjusting the ratio of N₂ and H₂ gas in a forming gas-based plasma can be used to tune a profile. The plasma power may also be used to tune an inhibition profile, with different ratios of active species tuned by plasma power. Process pressure can be used to tune a

profile, as pressure can cause more recombination (deactivating active species) as well as pushing active species further into a feature. Process time may also be used to tune inhibition profiles, with increasing treatment time causing inhibition deeper into a feature.

[0045] In some embodiments, selective inhibition can be achieved by performing operation 203 in a mass transport limited regime. In this regime, the inhibition rate inside the feature is limited by amounts of and/or relative compositions of different inhibition material components (e.g., an initial inhibition species, activated inhibition species, and recombined inhibition species) that diffuse into the feature. In certain examples, inhibition rates depend on various components' concentrations at different locations inside the feature.

[0046] Mass transport limiting conditions may be characterized, in part, by overall inhibition concentration variations. In certain embodiments, a concentration is less inside the feature than near its opening resulting in a higher inhibition rate near the opening than inside. This in turn leads to selective inhibition near the feature opening. Mass transport limiting process conditions may be achieved by supplying limited amounts of inhibition species into the processing chamber (e.g., use low inhibition gas flow rates relative to the cavity profile and dimensions), while maintaining relative high inhibition rates near the feature opening to consume some activated species as they diffuse into the feature. In certain embodiment, a concentration gradient is substantial, which may be caused relatively high inhibition kinetics and relatively low inhibition supply. In certain embodiments, an inhibition rate near the opening may also be mass transport limited, though this condition is not required to achieve selective inhibition.

[0047] In addition to the overall inhibition concentration variations inside features, selective inhibition may be influenced by relative concentrations of different inhibition species throughout the feature. These relative concentrations in turn can depend on relative dynamics of dissociation and recombination processes of the inhibition species. As described above, an initial inhibition material, such as molecular nitrogen, can be passed through a remote plasma generator and/or subjected to an in-situ plasma to generate activated species (e.g., atomic nitrogen, nitrogen ions). However, activated species may recombine into less active recombined species (e.g., nitrogen molecules) and/or react with W, WN, TiN, or other feature surfaces along

their diffusion paths. As such, different parts of the feature may be exposed to different concentrations of different inhibition materials, e.g., an initial inhibition gas, activated inhibition species, and recombined inhibition species. This provides additional opportunities for controlling selective inhibition. For example, activated species are generally more reactive than initial inhibition gases and recombined inhibition species. Furthermore, in some cases, the activated species may be less sensitive to temperature variations than the recombined species. Therefore, process conditions may be controlled in such a way that removal is predominantly attributed to activated species. As noted above, some species may be more reactive than others. Furthermore, specific process conditions may result in activated species being present at higher concentrations near features' openings than inside the features. For example, some activated species may be consumed (e.g., reacted with feature surface materials and/or adsorbed on the surface) and/or recombined while diffusing deeper into the features, especially in small high aspect ratio features. Recombination of activated species can also occur outside of features, e.g., in the showerhead or the processing chamber, and can depend on chamber pressure. Therefore, chamber pressure may be specifically controlled to adjust concentrations of activated species at various points of the chamber and features.

[0048] Flow rates of the inhibition gas can depend on a size of the chamber, reaction rates, and other parameters. A flow rate can be selected in such a way that more inhibition material is concentrated near the opening than inside the feature. In certain embodiments, these flow rates cause mass-transport limited selective inhibition. For example, a flow rate for a 195-liter chamber per station may be between about 25 sccm and 10,000 sccm or, in more specific embodiments, between about 50 sccm and 1,000 sccm. In certain embodiments, the flow rate is less than about 2,000 sccm, less than about 1,000 sccm, or more specifically less than about 500 sccm. It should be noted that these values are presented for one individual station configured for processing a 300-mm substrate. These flow rates can be scaled up or down depending on a substrate size, a number of stations in the apparatus (e.g., quadruple for a four station apparatus), a processing chamber volume, and other factors.

[0049] In certain embodiments, the substrate can be heated up or cooled down before selective inhibition. Various devices may be used to bring the substrate to the

predetermined temperature, such as a heating or cooling element in a station (e.g., an electrical resistance heater installed in a pedestal or a heat transfer fluid circulated through a pedestal), infrared lamps above the substrate, igniting plasma, etc.

[0050] A predetermined temperature for the substrate can be selected to induce a chemical reaction between the feature surface and inhibition species and/or promote adsorption of the inhibition species, as well as to control the rate of the reaction or adsorption. For example, a temperature may be selected to have high reaction rate such that more inhibition occurs near the opening than inside the feature. Furthermore, a temperature may be also selected to control recombination of activated species (e.g., recombination of atomic nitrogen into molecular nitrogen) and/or control which species (e.g., activated or recombined species) contribute predominantly to inhibition. In certain embodiments, a substrate is maintained at less than about 300°C, or more particularly at less than about 250°C, or less than about 150°C, or even less than about 100°C. In other embodiments, a substrate is heated to between about 300°C and 450°C or, in more specific embodiments, to between about 350°C and 400°C. Other temperature ranges may be used for different types of inhibition chemistries. Exposure time can also be selected to cause selective inhibition. Example exposure times can range from about 10 s to 500 s, depending on desired selectivity and feature depth.

[0051] As described above, aspects of the invention can be used for VNAND wordline (WL) fill. While the below discussion provides a framework for various methods, the methods are not so limited and can be implemented in other applications as well, including logic and memory contact fill, DRAM buried wordline fill, vertically integrated memory gate/wordline fill, and 3D integration (TSV).

[0052] Figure 1F, described above, provides an example of a VNAND wordline structure to be filled. As discussed above, feature fill of these structures can present several challenges including constrictions presented by pillar placement. In addition, a high feature density can cause a loading effect such that reactants are used up prior to complete fill.

[0053] Various methods are described below for void-free fill through the entire WL. In certain embodiments, low resistivity tungsten is deposited. Figure 5 shows a sequence in which non-conformal selective inhibition is used to fill in the interior of

the feature before pinch off. In Figure 5, a structure 500 is provided with a liner layer surface 502. The liner layer surface 502 may be for example, TiN or WN. Next, a W nucleation layer 504 is conformally deposited on the liner layer 502. A PNL process as described above can be used. Note that in some embodiments, this operation of depositing a conformal nucleation layer may be omitted. Next, the structure is exposed to an inhibition chemistry to selectively inhibit portions 506 of the structure 500. In this example, the portions 508 through the pillar constrictions 151 are selectively inhibited. Inhibition can involve for example, exposure to a direct (in-situ) plasma generated from a gas such as N₂, H₂, forming gas, NH₃, O₂, CH₄, etc. Other methods of exposing the feature to inhibition species are described above. Next, a CVD process is performed to selectively deposit tungsten in accordance with the inhibition profile: bulk tungsten 510 is preferentially deposited on the non-inhibited portions of the nucleation layer 504, such that hard-to-fill regions behind constrictions are filled. The remainder of the feature is then filled with bulk tungsten 510. As described above with reference to Figure 2, the same CVD process used to selectively deposit tungsten may be used to remainder of the feature, or a different CVD process using a different chemistry or process conditions and/or performed after a nucleation layer is deposited may be used.

[0054] In some embodiments, methods described herein may be used for tungsten via fill. Figure 6 shows an example of a feature hole 105 including a under-layer 113, which can be, for example, a metal nitride or other barrier layer. A tungsten layer 653 is conformally deposited in the feature hole 10, for example, by a PNL and/or CVD method. (Note that while the tungsten layer 653 is conformally deposited in the feature hole 105 in the example of Figure 6, in some other embodiments, tungsten nucleation on the under-layer 113 can be selectively inhibited prior to selective deposition of the tungsten layer 653.) Further deposition on the tungsten layer 653 is then selectively inhibited, forming inhibited portion 655 of the tungsten layer 653 near the feature opening. Tungsten is then selectively deposited by a PNL and/or CVD method in accordance with the inhibition profile such that tungsten is preferentially deposited near the bottom and mid-section of the feature. Deposition continues, in some embodiments with one or more selective inhibition cycles, until the feature is filled. As described above, in some embodiments, the inhibition effect at the feature top can be overcome by a long enough deposition time, while in some embodiments,

an additional nucleation layer deposition or other treatment may be performed to lessen or remove the passivation at the feature opening once deposition there is desired. Note that in some embodiments, feature fill may still include formation of a seam, such as seam 657 depicted in Figure 6. In other embodiments, the feature fill may be void-free and seam-free. Even if a seam is present, it may be smaller than obtained with a conventionally filled feature, reducing the problem of coring during CMP. The sequence depicted in the example of Figure 6 ends post-CMP with a relatively small void present.

[0055] In some embodiments, the processes described herein may be used advantageously even for features that do not have constrictions or possible pinch-off points. For example, the processes may be used for bottom-up, rather than conformal, fill of a feature. Figure 7 depicts a sequence in which a feature 700 is filled by a method according to certain embodiments. A thin conformal layer of tungsten 753 is deposited initially, followed by selective inhibition to form inhibited portions 755, layer 753 at the bottom of the feature not treated. CVD deposition results in a bulk film 757 deposited on at the bottom of the feature. This is then followed by repeated cycles of selective CVD deposition and selective inhibition until the feature is filled with bulk tungsten 757. Because nucleation on the sidewalls of the feature is inhibited except near the bottom of the feature, fill is bottom-up. In some embodiments, different parameters may be used in successive inhibitions to tune the inhibition profile appropriately as the bottom of the feature grows closer to the feature opening. For example, a bias power and/or treatment time may be decreased in successive inhibition treatments.

Experimental

[0056] 3D VNAND features similar to the schematic depiction in Figure 1F were exposed to plasmas generated from N_2H_2 gas after deposition of an initial tungsten seed layer. The substrate was biased with a DC bias, with bias power varied from 100 W to 700 W and exposure time varied between 20 s and 200 s. Longer time resulted in deeper and wider inhibition, with higher bias power resulting in deeper inhibition.

[0057] Table 1 shows effect of treatment time. All inhibition treatments used exposure to a direct LFRF 2000 W N_2H_2 plasma with a DC bias of 100 W on the substrate.

Table 1: Effect of treatment time on inhibition profile

	Initial Tungsten Layer	Inhibition Treatment Time	Subsequent Deposition	Selective Deposition
A	Nucleation + 30 s CVD at 300°C	None	400 s CVD at 300 °C	Non-selective deposition
B	same as A	60 s	same as A	Non-selective deposition
C	same as A	90 s	same as A	Yes – deposition only from bottom of feature to slightly less than vertical midpoint. Lateral deposition (wider) at bottom of feature.
D	same as A	140 s	same as A	No deposition

While varying treatment time resulted in vertical and lateral tuning of inhibition profile as described in Table 1 (split C), varying bias power correlated higher to vertical tuning of inhibition profile, with lateral variation a secondary effect.

[0058] As described above, the inhibition effect may be overcome by certain CVD conditions, including longer CVD time and/or higher temperatures, more aggressive chemistry, etc. Table 2 below, shows the effect of CVD time on selective deposition.

[0059] Table 2: Effect of CVD time on selective deposition

	Initial Tungsten Layer	Inhibition Treatment	Subsequent CVD Deposition Time (300 °C)	Selective Deposition
E	Nucleation +	H ₂ N ₂ 2000W RF	0	no deposition

	30 s CVD at 300°C	direct plasma, 90 s, 100 W DC bias		
F	same as E	same as E	200 s	Yes – small amount of deposition extending about 1/6 height of feature from bottom
G	same as E	same as E	400 s	Yes – deposition only from bottom of feature to slightly less than vertical midpoint. Lateral deposition wider at bottom of feature.
H	same as E	same as E	700 s	Yes – deposition through full height of feature, with lateral deposition wider at bottom of feature

Apparatus

[0060] Any suitable chamber may be used to implement this novel method. Examples of deposition apparatuses include various systems, e.g., ALTUS and ALTUS Max, available from Novellus Systems, Inc. of San Jose, California, or any of a variety of other commercially available processing systems.

[0061] Figure 8 illustrates a schematic representation of an apparatus 800 for processing a partially fabricated semiconductor substrate in accordance with certain embodiments. The apparatus 800 includes a chamber 818 with a pedestal 820, a shower head 814, and an in-situ plasma generator 816. The apparatus 800 also

includes a system controller 822 to receive input and/or supply control signals to various devices.

[0062] In certain embodiments, an inhibition gas and, if present, inert gases, such as argon, helium and others, can be supplied to the remote plasma generator 806 from a source 802, which may be a storage tank. Any suitable remote plasma generator may be used for activating the etchant before introducing it into the chamber 818. For example, a Remote Plasma Cleaning (RPC) units, such as ASTRON® i Type AX7670, ASTRON® e Type AX7680, ASTRON® ex Type AX7685, ASTRON® hf-s Type AX7645, all available from MKS Instruments of Andover, Massachusetts, may be used. An RPC unit is typically a self-contained device generating weakly ionized plasma using the supplied etchant. Imbedded into the RPC unit a high power RF generator provides energy to the electrons in the plasma. This energy is then transferred to the neutral inhibition gas molecules leading to temperature in the order of 2000K causing thermal dissociation of these molecules. An RPC unit may dissociate more than 60% of incoming molecules because of its high RF energy and special channel geometry causing the gas to adsorb most of this energy.

[0063] In certain embodiments, an inhibition gas is flown from the remote plasma generator 806 through a connecting line 808 into the chamber 818, where the mixture is distributed through the shower head 814. In other embodiments, an inhibition gas is flown into the chamber 818 directly completely bypassing the remote plasma generator 806 (e.g., the system 800 does not include such generator). Alternatively, the remote plasma generator 806 may be turned off while flowing the inhibition gas into the chamber 818, for example, because activation of the inhibition gas is not needed or will be supplied by an in situ plasma generator.

[0064] The shower head 814 or the pedestal 820 typically may have an internal plasma generator 816 attached to it. In one example, the generator 816 is a High Frequency (HF) generator capable of providing between about 0 W and 10,000 W at frequencies between about 1 MHz and 100 MHz. In another example, the generator 816 is a Low Frequency (LF) generator capable of providing between about 0 W and 10,000 W at frequencies as low as about 100 KHz. In a more specific embodiment, a HF generator may deliver between about 0 W to 5,000 W at about 13.56 MHz. The RF generator 816 may generate in-situ plasma to active inhibition species. In certain

embodiments, the RF generator 816 can be used with the remote plasma generator 806 or not used. In certain embodiments, no plasma generator is used during deposition.

[0065] The chamber 818 may include a sensor 824 for sensing various process parameters, such as degree of deposition, concentrations, pressure, temperature, and others. The sensor 824 may provide information on chamber conditions during the process to the system controller 822. Examples of the sensor 824 include mass flow controllers, pressure sensors, thermocouples, and others. The sensor 824 may also include an infra-red detector or optical detector to monitor presence of gases in the chamber and control measures.

[0066] Deposition and selective inhibition operations can generate various volatile species that are evacuated from the chamber 818. Moreover, processing is performed at certain predetermined pressure levels the chamber 818. Both of these functions are achieved using a vacuum outlet 826, which may be a vacuum pump.

[0067] In certain embodiments, a system controller 822 is employed to control process parameters. The system controller 822 typically includes one or more memory devices and one or more processors. The processor may include a CPU or computer, analog and/or digital input/output connections, stepper motor controller boards, etc. Typically there will be a user interface associated with system controller 822. The user interface may include a display screen, graphical software displays of the apparatus and/or process conditions, and user input devices such as pointing devices, keyboards, touch screens, microphones, etc.

[0068] In certain embodiments, the system controller 822 controls the substrate temperature, inhibition gas flow rate, power output of the remote plasma generator 806 and/or in situ plasma generator 816, pressure inside the chamber 818 and other process parameters. The system controller 822 executes system control software including sets of instructions for controlling the timing, mixture of gases, chamber pressure, chamber temperature, and other parameters of a particular process. Other computer programs stored on memory devices associated with the controller may be employed in some embodiments.

[0069] The computer program code for controlling the processes in a process sequence can be written in any conventional computer readable programming language: for example, assembly language, C, C++, Pascal, Fortran or others.

Compiled object code or script is executed by the processor to perform the tasks identified in the program. The system software may be designed or configured in many different ways. For example, various chamber component subroutines or control objects may be written to control operation of the chamber components necessary to carry out the described processes. Examples of programs or sections of programs for this purpose include process gas control code, pressure control code, and plasma control code.

[0070] The controller parameters relate to process conditions such as, for example, timing of each operation, pressure inside the chamber, substrate temperature, inhibition gas flow rates, etc. These parameters are provided to the user in the form of a recipe, and may be entered utilizing the user interface. Signals for monitoring the process may be provided by analog and/or digital input connections of the system controller 822. The signals for controlling the process are output on the analog and digital output connections of the apparatus 800.

Multi-Station Apparatus

[0071] Figure 9A shows an example of a multi-station apparatus 900. The apparatus 900 includes a process chamber 901 and one or more cassettes 903 (e.g., Front Opening Unified Pods) for holding substrates to be processed and substrates that have completed processing. The chamber 901 may have a number of stations, for example, two stations, three stations, four stations, five stations, six stations, seven stations, eight stations, ten stations, or any other number of stations. The number of stations is usually determined by a complexity of the processing operations and a number of these operations that can be performed in a shared environment. Figure 9A illustrates the process chamber 901 that includes six stations, labeled 911 through 916. All stations in the multi-station apparatus 900 with a single process chamber 903 are exposed to the same pressure environment. However, each station may have a designated reactant distribution system and local plasma and heating conditions achieved by a dedicated plasma generator and pedestal, such as the ones illustrated in Figure 8.

[0072] A substrate to be processed is loaded from one of the cassettes 903 through a load-lock 905 into the station 911. An external robot 907 may be used to transfer the substrate from the cassette 903 and into the load-lock 905. In the depicted

embodiment, there are two separate load locks 905. These are typically equipped with substrate transferring devices to move substrates from the load-lock 905 (once the pressure is equilibrated to a level corresponding to the internal environment of the process chamber 903) into the station 911 and from the station 916 back into the load-lock 905 for removal from the processing chamber 903. A mechanism 909 is used to transfer substrates among the processing stations 911-916 and support some of the substrates during the process as described below.

[0073] In certain embodiments, one or more stations may be reserved for heating the substrate. Such stations may have a heating lamp (not shown) positioned above the substrate and/or a heating pedestal supporting the substrate similar to one illustrated in Figure 8. For example, a station 911 may receive a substrate from a load-lock and be used to pre-heat the substrate before being further processed. Other stations may be used for filling high aspect ratio features including deposition and selective inhibition operations.

[0074] After the substrate is heated or otherwise processed at the station 911, the substrate is moved successively to the processing stations 912, 913, 914, 915, and 916, which may or may not be arranged sequentially. The multi-station apparatus 900 can be configured such that all stations are exposed to the same pressure environment. In so doing, the substrates are transferred from the station 911 to other stations in the chamber 901 without a need for transfer ports, such as load-locks.

[0075] In certain embodiments, one or more stations may be used to fill features with tungsten-containing materials. For example, stations 912 may be used for an initial deposition operation, station 913 may be used for a corresponding selective inhibition operation. In the embodiments where a deposition-inhibition cycle is repeated, stations 914 may be used for another deposition operations and station 915 may be used for another inhibition operation. Section 916 may be used for the final filling operation. It should be understood that any configurations of station designations to specific processes (heating, filling, and removal) may be used. In some implementations, any of the stations can be dedicated to one or more of PNL (or ALD) deposition, selective inhibition, and CVD deposition.

[0076] As an alternative to the multi-station apparatus described above, the method may be implemented in a single substrate chamber or a multi-station chamber

processing a substrate(s) in a single processing station in batch mode (i.e., non-sequential). In this aspect of the invention, the substrate is loaded into the chamber and positioned on the pedestal of the single processing station (whether it is an apparatus having only one processing station or an apparatus having multi-stations running in batch mode). The substrate may be then heated and the deposition operation may be conducted. The process conditions in the chamber may be then adjusted and the selective inhibition of the deposited layer is then performed. The process may continue with one or more deposition-inhibition cycles (if performed) and with the final filling operation all performed on the same station. Alternatively, a single station apparatus may be first used to perform only one of the operation in the new method (e.g., depositing, selective inhibition, final filling) on multiple substrates after which the substrates may be returned back to the same station or moved to a different station (e.g., of a different apparatus) to perform one or more of the remaining operations.

Multi-chamber Apparatus

[0077] FIG. 9B is a schematic illustration of a multi-chamber apparatus 920 that may be used in accordance with certain embodiments. As shown, the apparatus 920 has three separate chambers 921, 923, and 925. Each of these chambers is illustrated with two pedestals. It should be understood that an apparatus may have any number of chambers (e.g., one, two, three, four, five, six, etc.) and each chamber may have any number of pedestals (e.g., one, two, three, four, five, six, etc.). Each chamber 921-925 has its own pressure environment, which is not shared between chambers. Each chamber may have one or more corresponding transfer ports (e.g., load-locks). The apparatus may also have a shared substrate handling robot 927 for transferring substrates between the transfer ports one or more cassettes 929.

[0078] As noted above, separate chambers may be used for depositing tungsten containing materials and selective inhibition of these deposited materials in later operations. Separating these two operations into different chambers can help to substantially improve processing speeds by maintaining the same environmental conditions in each chamber. A chamber does not need to change its environment from conditions used for deposition to conditions used for selective inhibition and back, which may involve different chemistries, different temperatures, pressures, and other process parameters. In certain embodiments, it is faster to transfer partially

manufactured semiconductor substrates between two or more different chambers than changing environmental conditions of these chambers.

Patterning Method/Apparatus:

[0079] The apparatus/process described hereinabove may be used in conjunction with lithographic patterning tools or processes, for example, for the fabrication or manufacture of semiconductor devices, displays, LEDs, photovoltaic panels and the like. Typically, though not necessarily, such tools/processes will be used or conducted together in a common fabrication facility. Lithographic patterning of a film typically comprises some or all of the following steps, each step enabled with a number of possible tools: (1) application of photoresist on a workpiece, i.e., substrate, using a spin-on or spray-on tool; (2) curing of photoresist using a hot plate or furnace or UV curing tool; (3) exposing the photoresist to visible or UV or x-ray light with a tool such as a wafer stepper; (4) developing the resist so as to selectively remove resist and thereby pattern it using a tool such as a wet bench; (5) transferring the resist pattern into an underlying film or workpiece by using a dry or plasma-assisted etching tool; and (6) removing the resist using a tool such as an RF or microwave plasma resist stripper.

Claims

1. A method comprising:
 - providing a substrate including a feature having one or more feature openings and a feature interior,
 - selectively inhibiting tungsten nucleation in the feature such that there is a differential inhibition profile along a feature axis, wherein selective inhibition is performed without etching material in the feature; and
 - selectively depositing tungsten in the feature in accordance with the differential inhibition profile.
2. The method of claim 1, wherein selectively inhibiting tungsten nucleation in the feature comprises exposing the feature to a direct plasma while applying a bias to the substrate.
3. The method of claim 1, wherein selectively inhibiting tungsten nucleation in the feature comprises exposing the feature to a remotely-generated plasma.
4. The method of claim 2 or 3, wherein the plasma contains one or more of nitrogen, hydrogen, oxygen and carbon activated species.
5. The method of claim 2 or 3, wherein the plasma is nitrogen-based and/or hydrogen-based.
6. The method of any of claims 1-5, further comprising depositing a tungsten layer in the feature prior to selective inhibition.
7. The method of claim 6, wherein the tungsten layer is deposited by a pulsed nucleation layer (PNL) process.
8. The method of claim 6, wherein the tungsten layer is conformally deposited in the feature.
9. The method of any of claims 1-8, wherein selectively depositing tungsten comprises a chemical vapor deposition (CVD) process.
10. The method of any of claims 1-9, further comprising, after selectively depositing tungsten in the feature, depositing tungsten in the feature to complete feature fill.

11. The method of any of claims 1-10, further comprising, after selectively depositing tungsten in the feature, non-selectively depositing tungsten in the feature.
12. The method of claim 11, wherein transitioning from selective to non-selective deposition comprises allowing a CVD process to continue without deposition of an intervening tungsten nucleation layer.
13. The method of claim 11, wherein transitioning from selective to non-selective deposition comprising deposition of a tungsten nucleation layer on the selectively deposited tungsten.
14. The method of any of claims 1-13, wherein selectively inhibiting tungsten nucleation comprises treating a tungsten surface of the feature.
15. The method of any of claims 1-13, wherein selectively inhibiting tungsten nucleation comprises treating a metal nitride surface of the feature.
16. The method of any of claims 1-15, wherein the feature fill is performed without etching material in the feature.
17. The method of any of claims 1-16, wherein the feature is part of a three-dimensional (3-D) structure.
18. The method of any of claims 1-17, further comprising repeating a cycle of selective inhibition and selective deposition one or more times to fill the feature.
19. The method of any of claims 1-18, wherein at least a constriction in the feature is selectively inhibited.
20. A method comprising:
 - exposing a horizontally-oriented feature in a three-dimensional (3-D) structure to a direct plasma to thereby selectively inhibit tungsten nucleation of a portion of the feature such that there is a differential inhibition profile in the feature; and
 - after selectively inhibiting a portion of the feature, performing a CVD operation to thereby selectively deposit tungsten in accordance with the differential inhibition profile.

21. A method comprising:

exposing an unfilled or partially filled feature on a substrate to a direct plasma to thereby selectively inhibit tungsten nucleation of a portion of the feature such that there is a differential inhibition profile in the feature; and

after selectively inhibiting a portion of the feature, performing a CVD operation to thereby selectively deposit tungsten in accordance with the differential inhibition profile.

22. An apparatus comprising:

one or more chambers configured to support a substrate;

an in situ plasma generator configured to generate a plasma in one or more of the chambers;

gas inlets configured to direct gas into each of the one or more chambers; and

a controller comprising program instructions for:

generating a nitrogen-based and/or hydrogen-based plasma while applying a bias power to the substrate such that the substrate is exposed to the plasma;

after exposing the substrate to the plasma, inletting a tungsten-containing precursor and a reducing agent to a chamber in which the substrate sits to deposit tungsten.

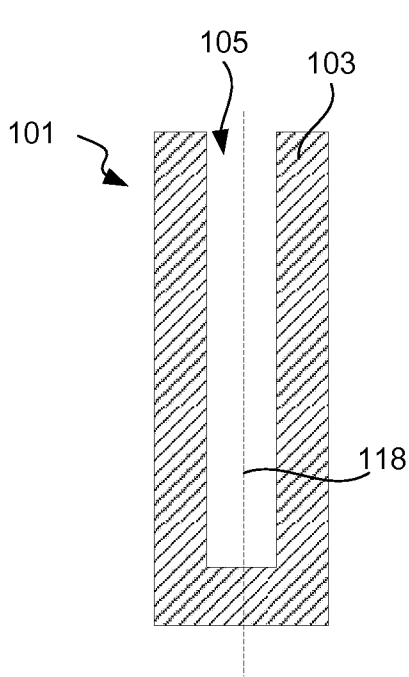

FIG. 1A

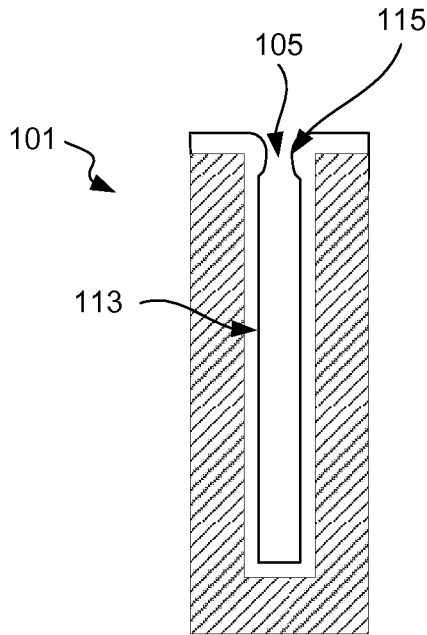

FIG. 1B

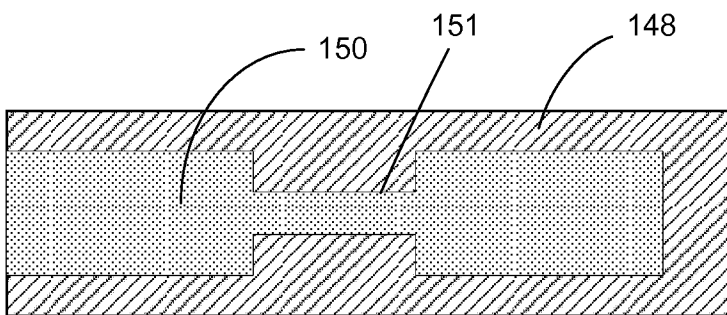

FIG. 1D

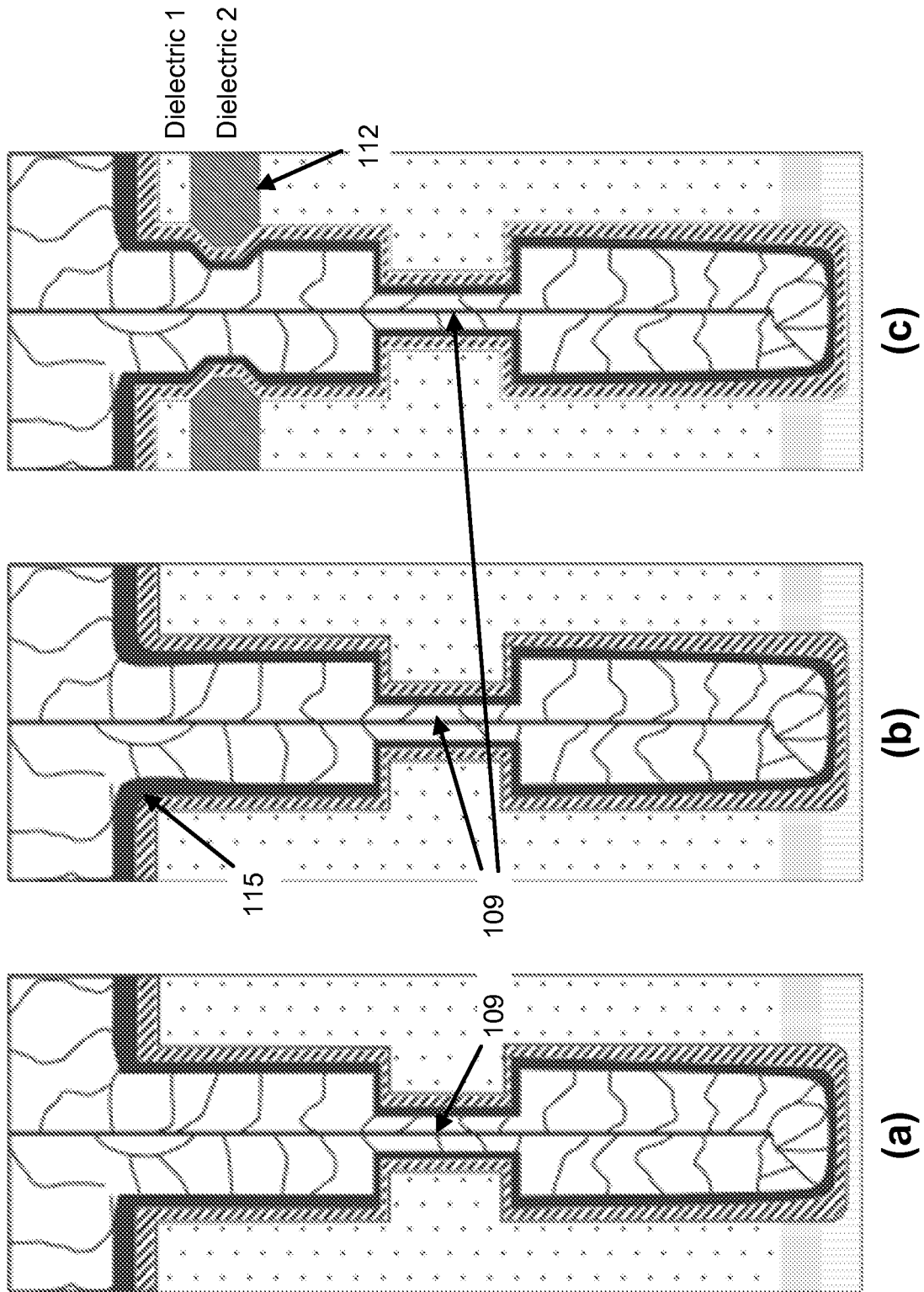

FIGURE 1C

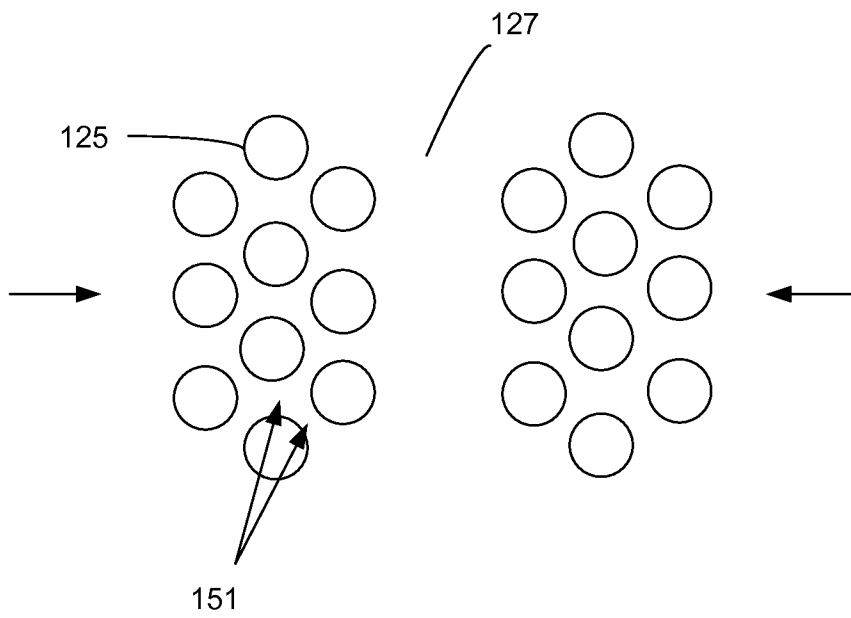

FIG. 1E

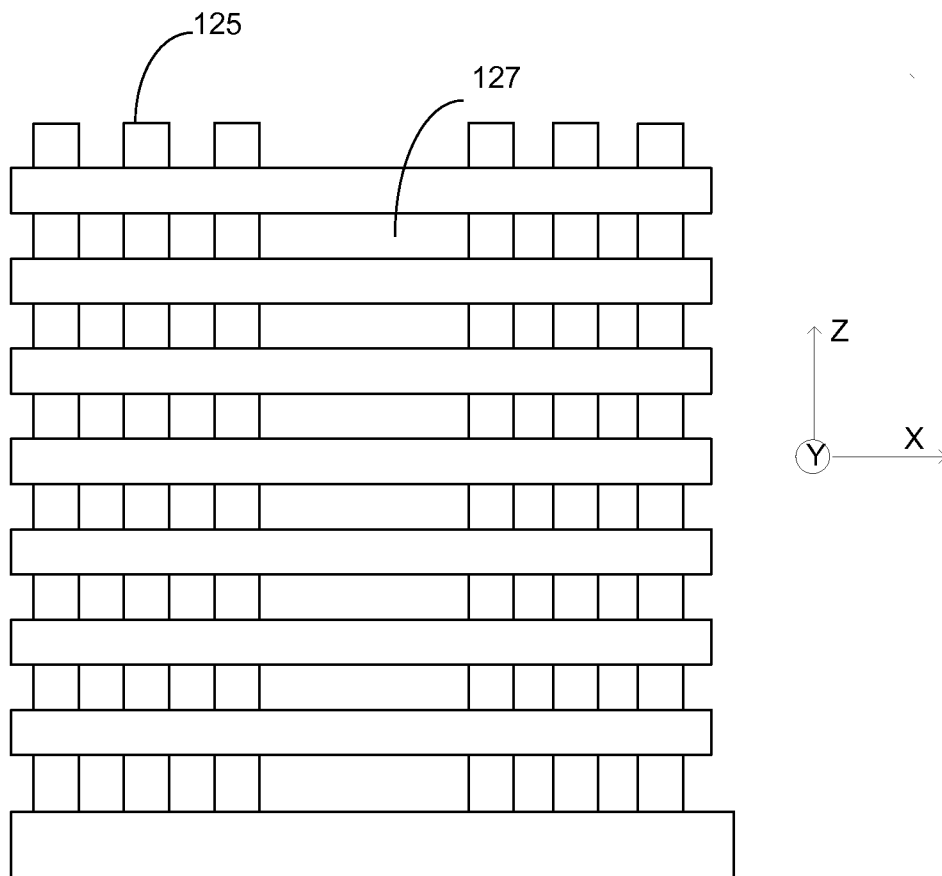

FIG. 1F

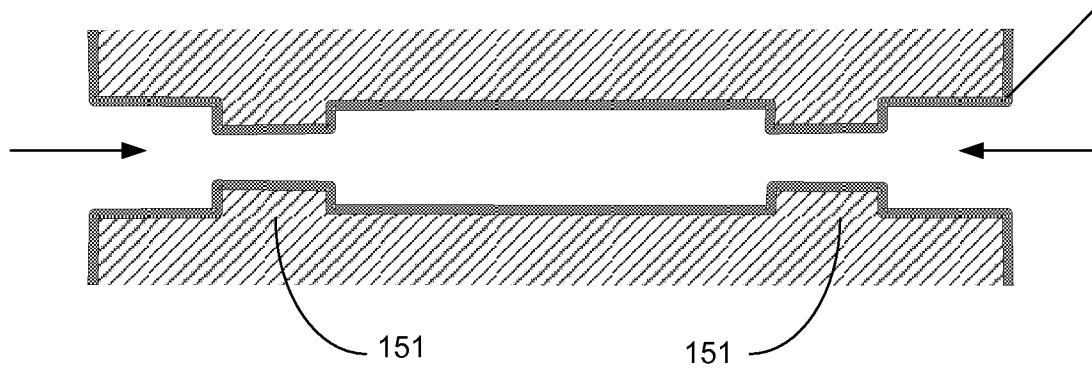

FIG. 1G

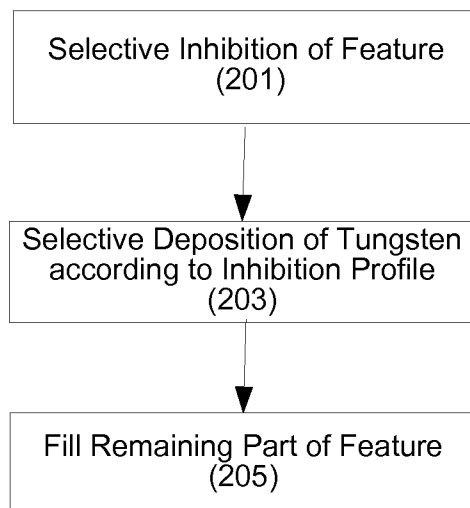
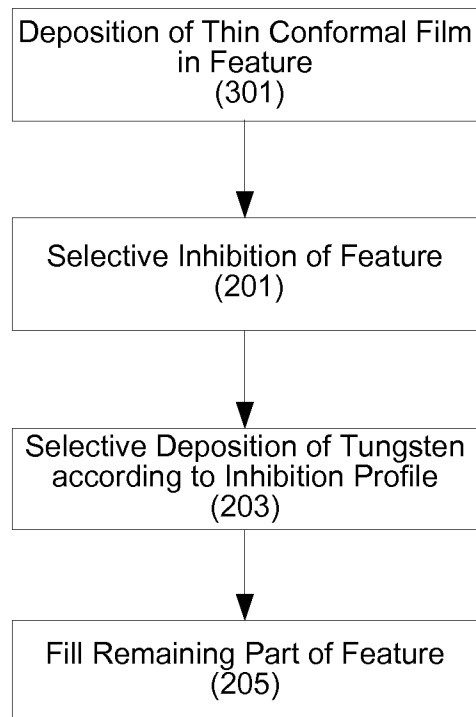
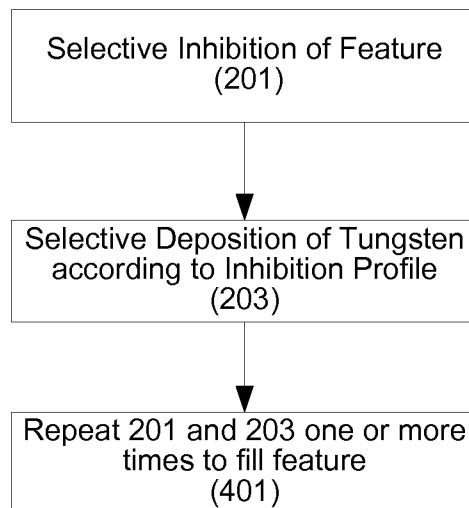

FIG. 2

**FIG. 3**

**FIG. 4**

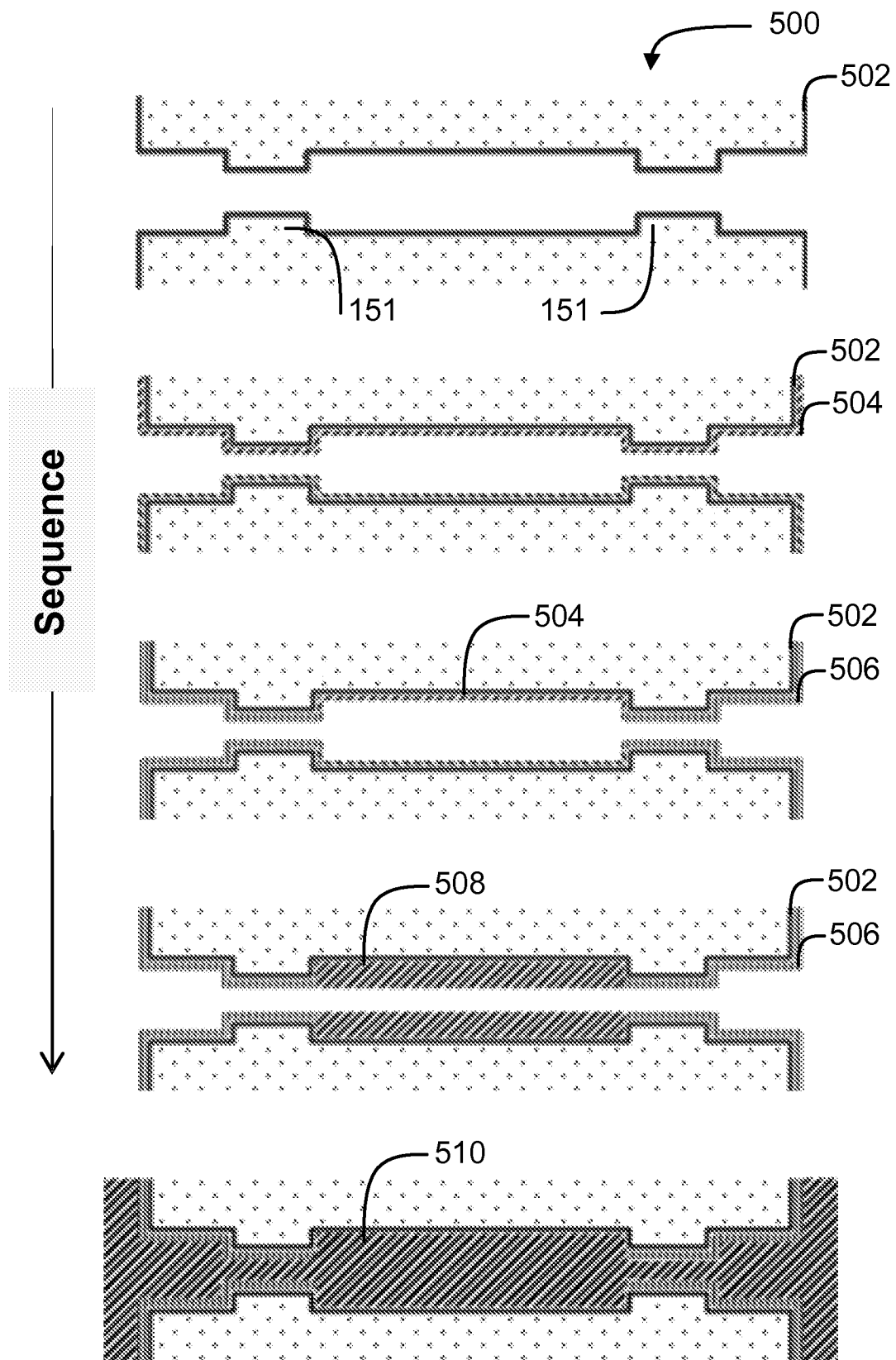

FIGURE 5

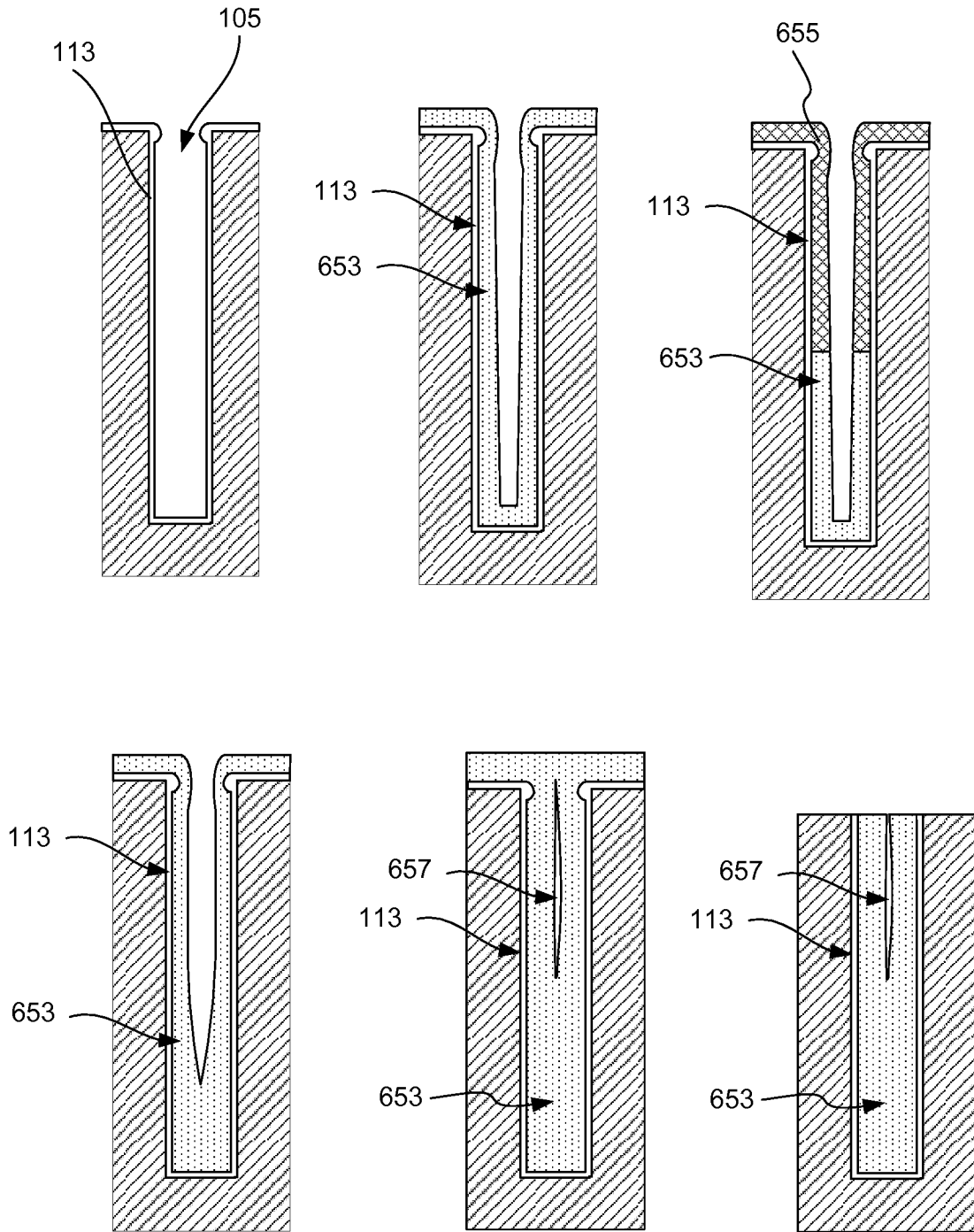

FIG. 6

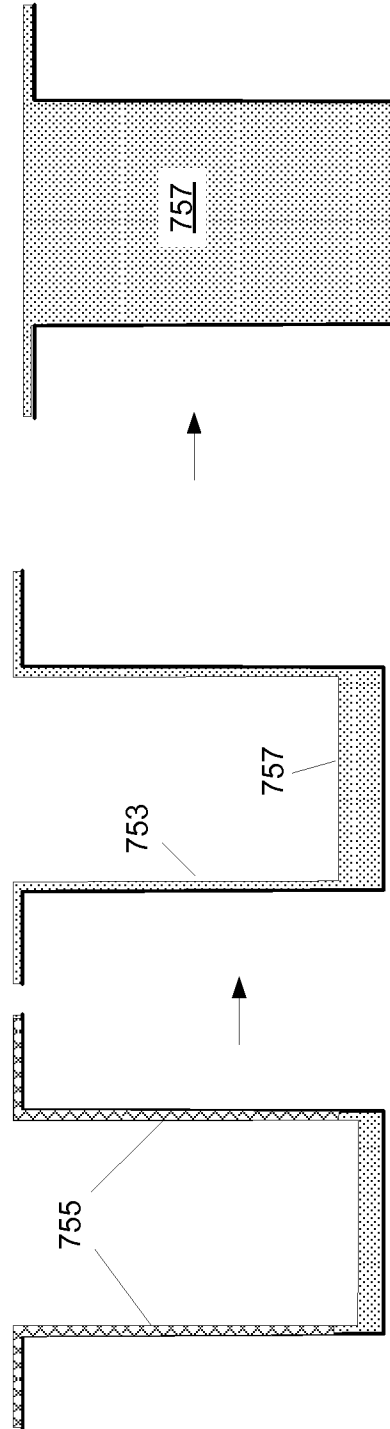
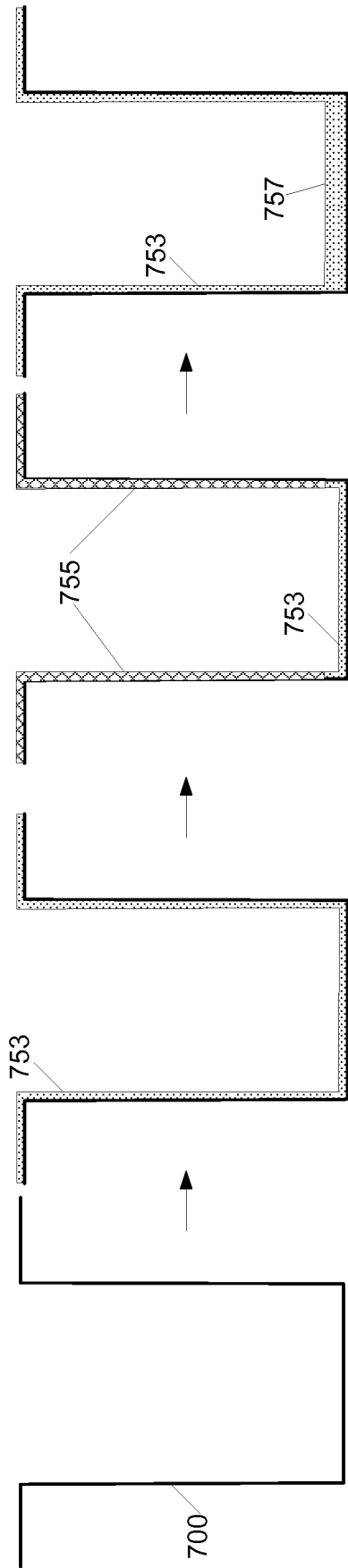

FIG. 7

□
repeat

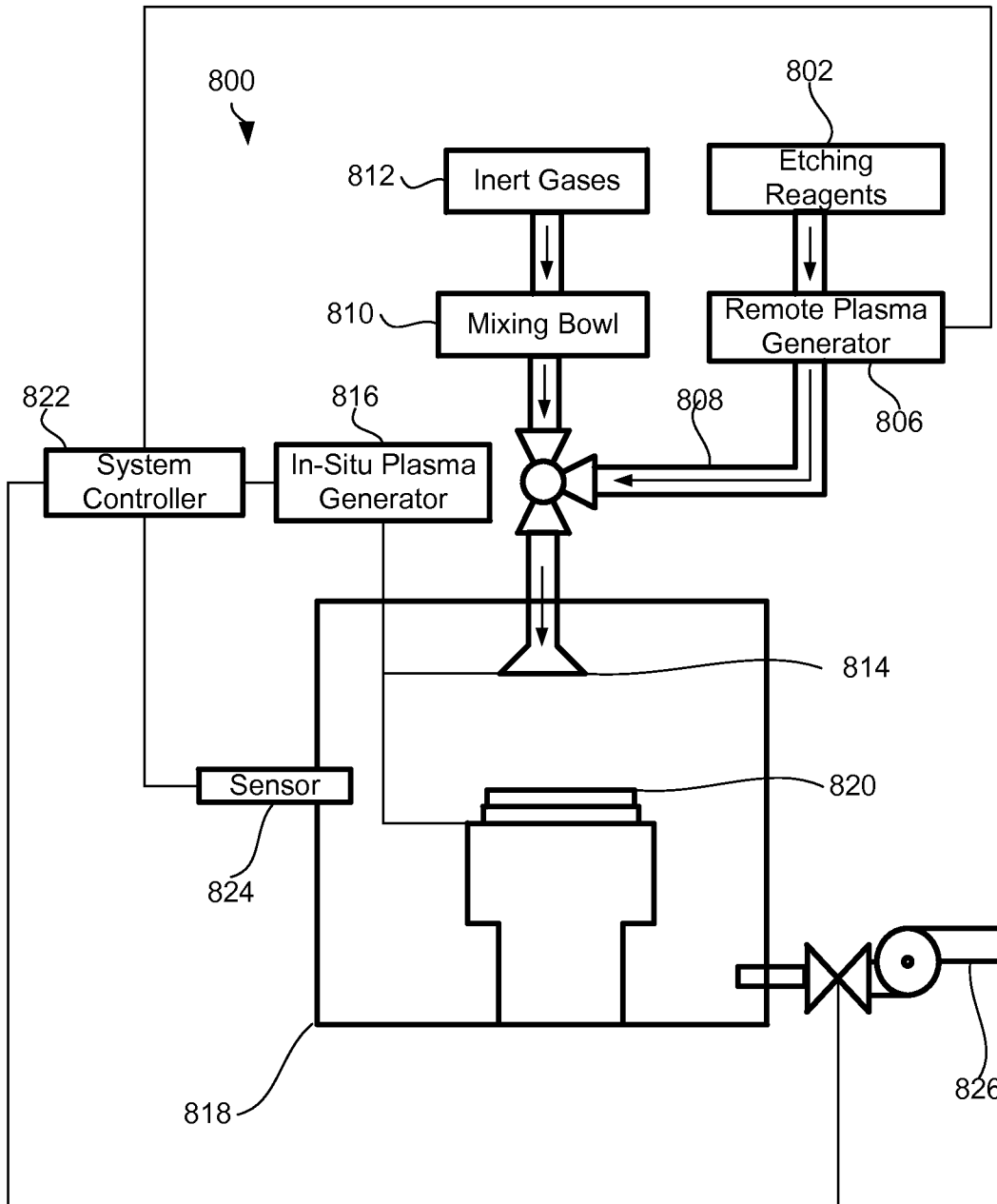

FIG. 8

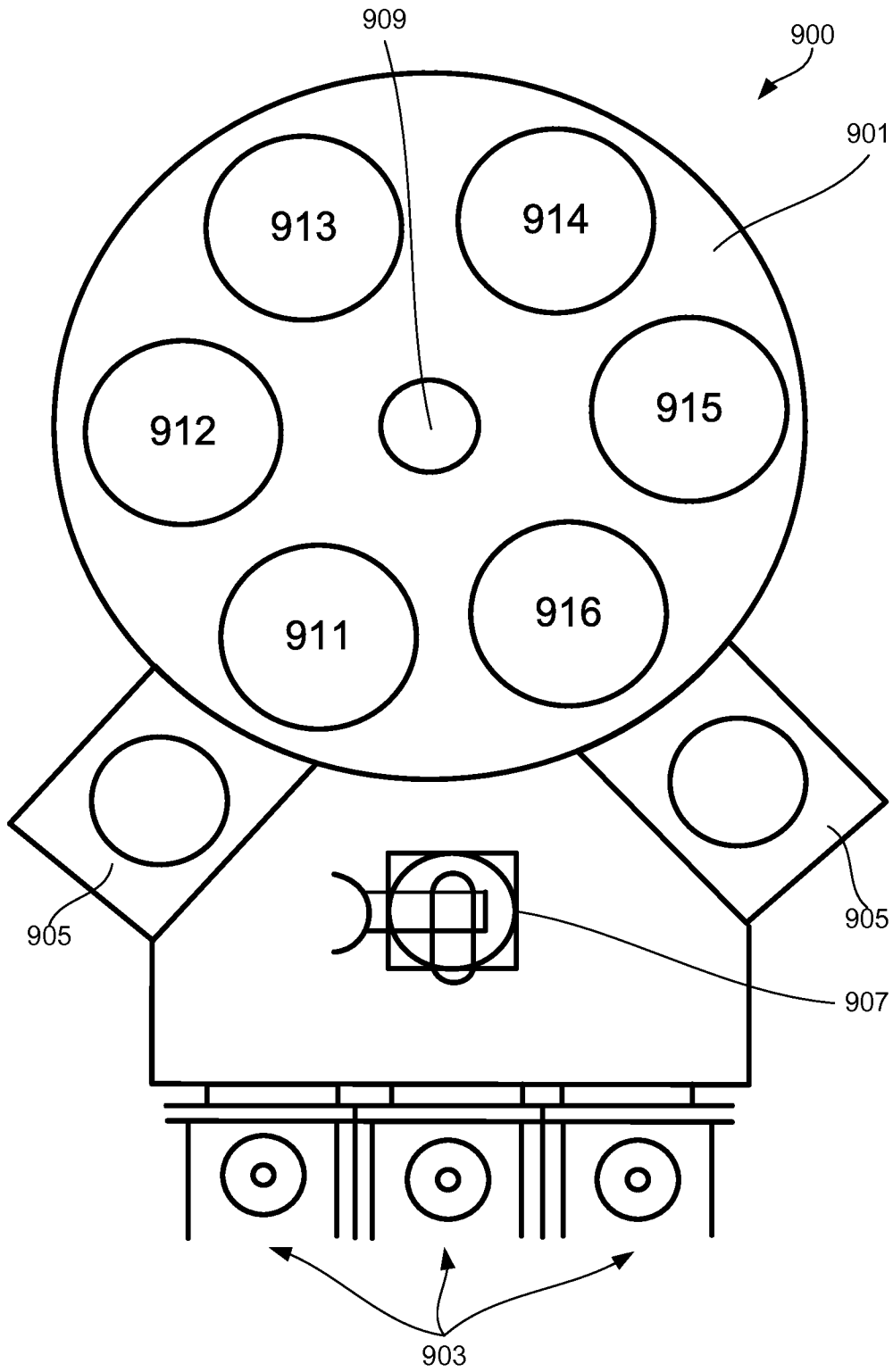

FIG. 9A

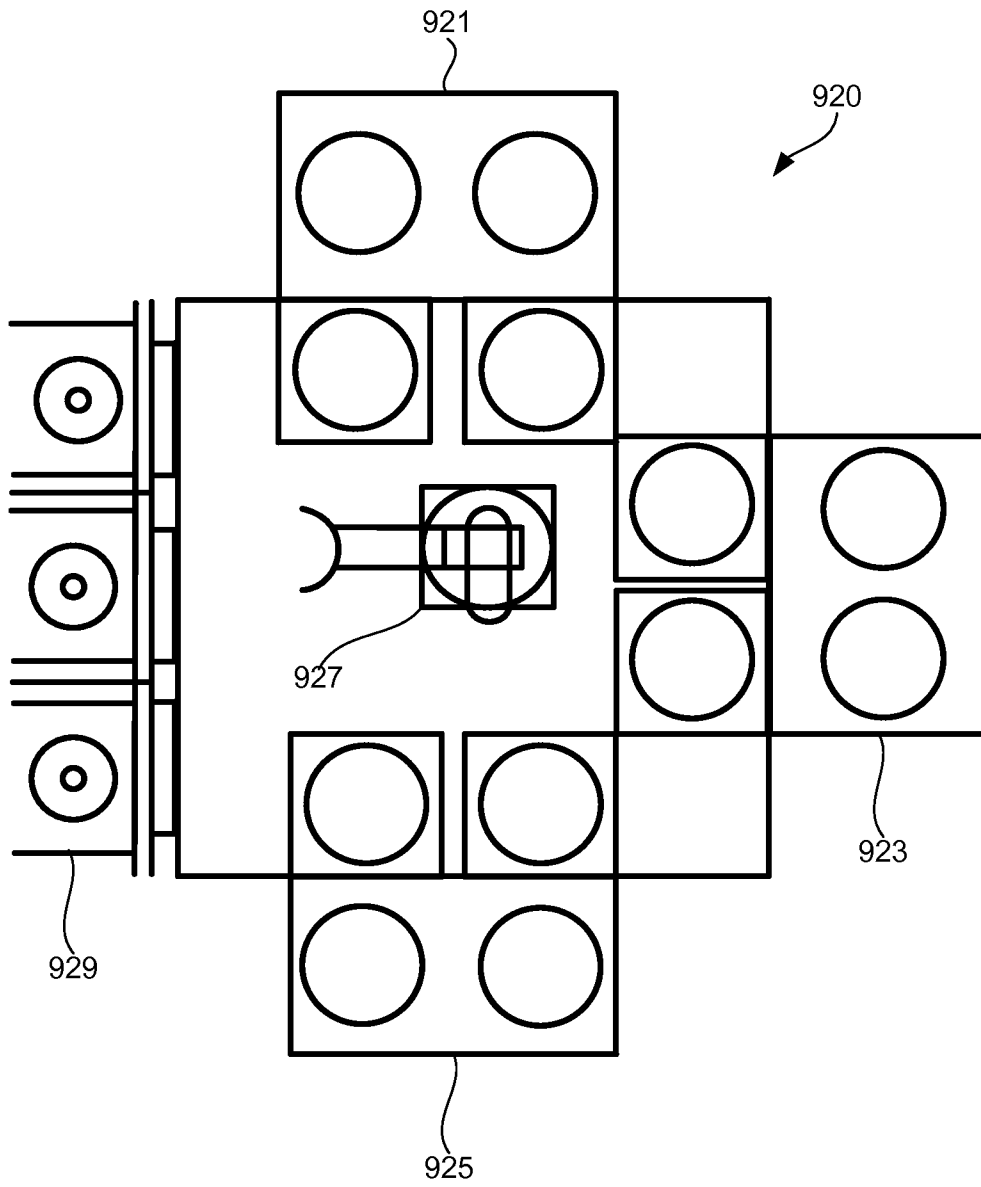

FIG. 9B

A. CLASSIFICATION OF SUBJECT MATTER**H01L 21/31(2006.01)i, H01L 21/205(2006.01)i**

According to International Patent Classification (IPC) or to both national classification and IPC

B. FIELDS SEARCHED

Minimum documentation searched (classification system followed by classification symbols)

H01L 21/31; H01L 23/52; H01L 21/768; H01L 21/4763; H01L 23/532; H01L 21/44; C23C 16/00; H01L 21/205

Documentation searched other than minimum documentation to the extent that such documents are included in the fields searched

Korean utility models and applications for utility models
Japanese utility models and applications for utility models

Electronic data base consulted during the international search (name of data base and, where practicable, search terms used)

eKOMPASS(KIPO internal) & Keywords: selective, inhibit, nucleation, profile and tungsten

C. DOCUMENTS CONSIDERED TO BE RELEVANT

Category*	Citation of document, with indication, where appropriate, of the relevant passages	Relevant to claim No.
X	US 2002-0132472 A1 (CHANG SOO PARK) 19 September 2002 See abstract; paragraphs [0025]-[0036] and figures 2A-2D.	1-3, 20-21
Y		4-5
A		22
Y	US 2009-0053893 A1 (AMIT KHANDELWAL et al.) 26 February 2009 See abstract; paragraphs [0011]-[0017], [0065]-[0086] and figures 3A-4C.	4-5, 22
Y	US 2006-0075966 A1 (CHEN-AN CHEN et al.) 13 April 2006 See abstract; paragraphs [0028]-[0052], [0089] and figures 2-3, 5-6, 12A.	22
A	US 2005-0179141 A1 (JU-YOUNG YUN et al.) 18 August 2005 See paragraphs [0027]-[0049] and figures 2A-2F.	1-5, 20-22
A	US 2011-0233778 A1 (SANG-HYEOB LEE et al.) 29 September 2011 See abstract; paragraphs [0017]-[0048] and figures 1A-5.	1-5, 20-22



Further documents are listed in the continuation of Box C.



See patent family annex.

* Special categories of cited documents:

"A" document defining the general state of the art which is not considered to be of particular relevance

"E" earlier application or patent but published on or after the international filing date

"L" document which may throw doubts on priority claim(s) or which is cited to establish the publication date of citation or other special reason (as specified)

"O" document referring to an oral disclosure, use, exhibition or other means

"P" document published prior to the international filing date but later than the priority date claimed

"T" later document published after the international filing date or priority date and not in conflict with the application but cited to understand the principle or theory underlying the invention

"X" document of particular relevance; the claimed invention cannot be considered novel or cannot be considered to involve an inventive step when the document is taken alone

"Y" document of particular relevance; the claimed invention cannot be considered to involve an inventive step when the document is combined with one or more other such documents, such combination being obvious to a person skilled in the art

"&" document member of the same patent family

Date of the actual completion of the international search

26 June 2013 (26.06.2013)

Date of mailing of the international search report

28 June 2013 (28.06.2013)

Name and mailing address of the ISA/KR

Korean Intellectual Property Office
189 Cheongsa-ro, Seo-gu, Daejeon Metropolitan City,
302-701, Republic of Korea

Facsimile No. 82-42-472-7140

Authorized officer

CHOI, Sang Won

Telephone No. 82-42-481-8291



Box No. II Observations where certain claims were found unsearchable (Continuation of item 2 of first sheet)

This international search report has not been established in respect of certain claims under Article 17(2)(a) for the following reasons:

1. Claims Nos.:
because they relate to subject matter not required to be searched by this Authority, namely:

2. Claims Nos.: 7-8, 12-13
because they relate to parts of the international application that do not comply with the prescribed requirements to such an extent that no meaningful international search can be carried out, specifically:
Claims 7-8, 12-13 are unclear, because they refer to multiple dependent claims which do not comply with PCT Rule 6.4(a).

3. Claims Nos.: 6, 9-11, 14-19
because they are dependent claims and are not drafted in accordance with the second and third sentences of Rule 6.4(a).

Box No. III Observations where unity of invention is lacking (Continuation of item 3 of first sheet)

This International Searching Authority found multiple inventions in this international application, as follows:

1. As all required additional search fees were timely paid by the applicant, this international search report covers all searchable claims.

2. As all searchable claims could be searched without effort justifying an additional fee, this Authority did not invite payment of any additional fee.

3. As only some of the required additional search fees were timely paid by the applicant, this international search report covers only those claims for which fees were paid, specifically claims Nos.:

4. No required additional search fees were timely paid by the applicant. Consequently, this international search report is restricted to the invention first mentioned in the claims; it is covered by claims Nos.:

Remark on Protest

- The additional search fees were accompanied by the applicant's protest and, where applicable, the payment of a protest fee.
- The additional search fees were accompanied by the applicant's protest but the applicable protest fee was not paid within the time limit specified in the invitation.
- No protest accompanied the payment of additional search fees.

INTERNATIONAL SEARCH REPORT

Information on patent family members

International application No.
PCT/US2013/033174

Patent document cited in search report	Publication date	Patent family member(s)	Publication date
US 2002-0132472 A1	19.09.2002	KR 10-2002-0072996 A	19.09.2002
US 2009-0053893 A1	26.02.2009	CN 101308794 A	19.11.2008
		CN 101308794 B	15.09.2010
		CN 101308794 C0	19.11.2008
		CN 1332267 A0	23.01.2002
		EP 1167567 A1	02.01.2002
		JP 2002-038271 A	06.02.2002
		JP 2004-536225 A	02.12.2004
		JP 2005-505690 A	24.02.2005
		JP 2008-303466 A	18.12.2008
		JP 2009-024252 A	05.02.2009
		JP 4705325 B2	22.06.2011
		JP 5021123 B2	05.09.2012
		JP 5048602 B2	17.10.2012
		KR 10-0731399 B1	21.06.2007
		KR 10-0978993 B1	30.08.2010
		KR 10-2008-0101745 A	21.11.2008
		TW 200914630 A	01.04.2009
		TW 200929384 A	01.07.2009
		US 2003-0013300 A1	16.01.2003
		US 2003-0104126 A1	05.06.2003
		US 2004-0209465 A1	21.10.2004
		US 2004-0247788 A1	09.12.2004
		US 2005-0059241 A1	17.03.2005
		US 2005-0208763 A1	22.09.2005
		US 2006-0009034 A1	12.01.2006
		US 2006-0040052 A1	23.02.2006
		US 2006-0128132 A1	15.06.2006
		US 2006-0264031 A1	23.11.2006
		US 2006-0292874 A1	28.12.2006
		US 2007-0218688 A1	20.09.2007
		US 2007-0254481 A1	01.11.2007
		US 2008-0014724 A1	17.01.2008
		US 2008-0280438 A1	13.11.2008
		US 2009-0081866 A1	26.03.2009
		US 2009-0156003 A1	18.06.2009
		US 2009-0156004 A1	18.06.2009
		US 2010-0093170 A1	15.04.2010
		US 2011-244682 A1	06.10.2011
		US 6551929 B1	22.04.2003
		US 6797340 B2	28.09.2004
		US 6855368 B1	15.02.2005
		US 6936538 B2	30.08.2005
		US 7033922 B2	25.04.2006
		US 7101795 B1	05.09.2006
		US 7115494 B2	03.10.2006
		US 7220673 B2	22.05.2007
		US 7235486 B2	26.06.2007

INTERNATIONAL SEARCH REPORT

Information on patent family members

International application No.

PCT/US2013/033174

Patent document cited in search report	Publication date	Patent family member(s)	Publication date
		US 7238552 B2	03.07.2007
		US 7405158 B2	29.07.2008
		US 7465665 B2	16.12.2008
		US 7465666 B2	16.12.2008
		US 7674715 B2	09.03.2010
		US 7709385 B2	04.05.2010
		US 7732327 B2	08.06.2010
		US 7745333 B2	29.06.2010
		US 7749815 B2	06.07.2010
		US 7846840 B2	07.12.2010
		US 7964505 B2	21.06.2011
		WO 03-009360 A2	30.01.2003
		WO 03-009360 A3	30.10.2003
		WO 03-031679 A2	17.04.2003
		WO 03-031679 A3	21.08.2003
		WO 2006-078779 A2	27.07.2006
		WO 2006-078779 A3	23.04.2009
		WO 2009-042713 A1	02.04.2009
US 2006-0075966 A1	13.04.2006	US 2003-0143328 A1	31.07.2003
		US 2003-0143841 A1	31.07.2003
		US 2005-0277290 A1	15.12.2005
		US 2006-0292864 A1	28.12.2006
		US 2009-0111264 A1	30.04.2009
		US 6911391 B2	28.06.2005
		US 6998014 B2	14.02.2006
		US 7094685 B2	22.08.2006
		US 7473638 B2	06.01.2009
		US 7732325 B2	08.06.2010
		US 7779784 B2	24.08.2010
		WO 03-064059 A2	07.08.2003
		WO 03-064059 A3	26.02.2004
US 2005-0179141 A1	18.08.2005	KR 10-0446300 B1	30.08.2004
		KR 10-0564605 B1	28.03.2006
		KR 10-2003-0092583 A	06.12.2003
		US 2003-0222346 A1	04.12.2003
		US 2005-0158990 A1	21.07.2005
		US 2008-0070405 A1	20.03.2008
		US 6955983 B2	18.10.2005
		US 7384866 B2	10.06.2008
US 2011-0233778 A1	29.09.2011	TW 201145461 A	16.12.2011
		WO 2011-119293 A2	29.09.2011
		WO 2011-119293 A3	22.12.2011