

No. 776,889.

PATENTED DEC. 6, 1904.

A. V. CLELAND.
SMUT MACHINE.

APPLICATION FILED APR. 8, 1904.

NO MODEL.

3 SHEETS SHEET 1.

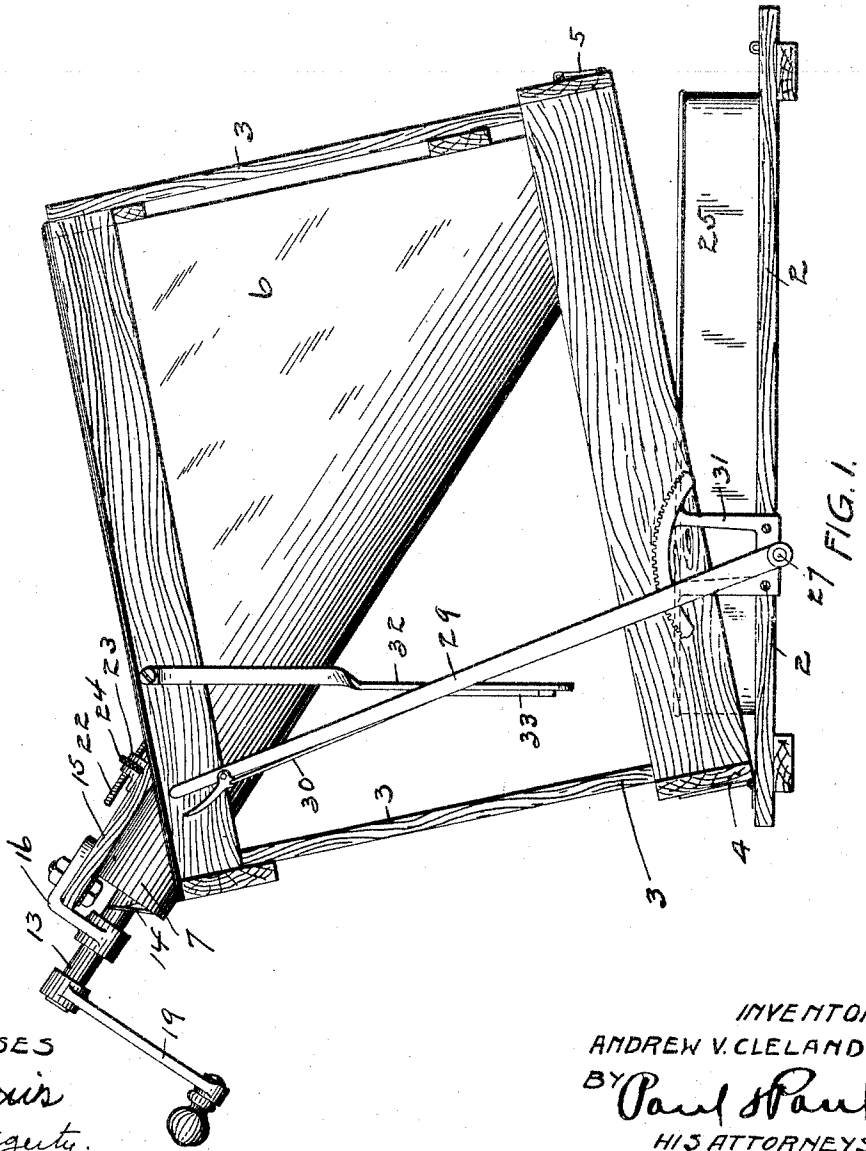
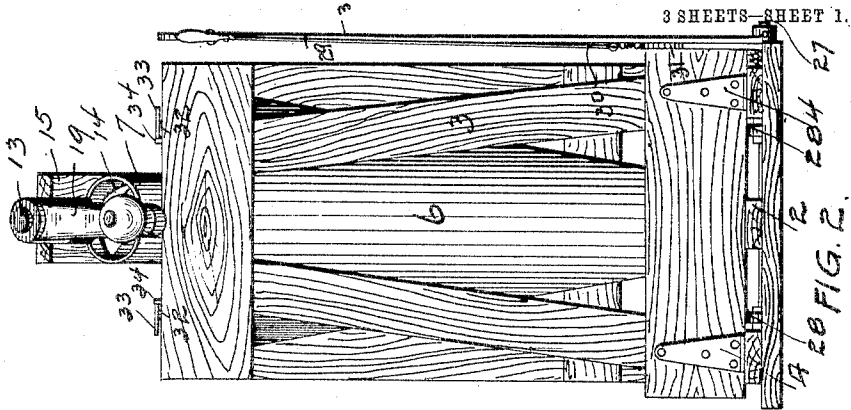

WITNESSES
M. M. Davis
M. Hagerty

INVENTOR
 ANDREW V. CLELAND
 BY *Paul Paul*
 HIS ATTORNEYS

A. V. CLELAND.
SMUT MACHINE.

APPLICATION FILED APR. 8, 1904.

NO MODEL.

3 SHEETS—SHEET 2.

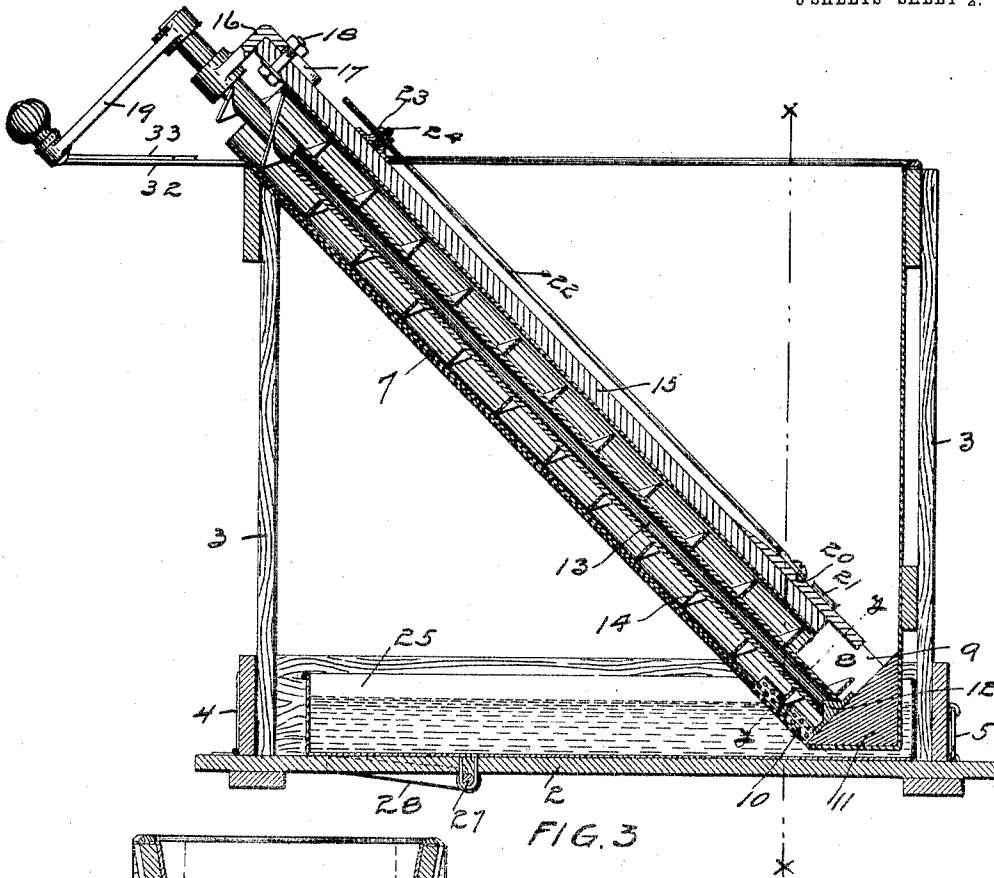

FIG. 3

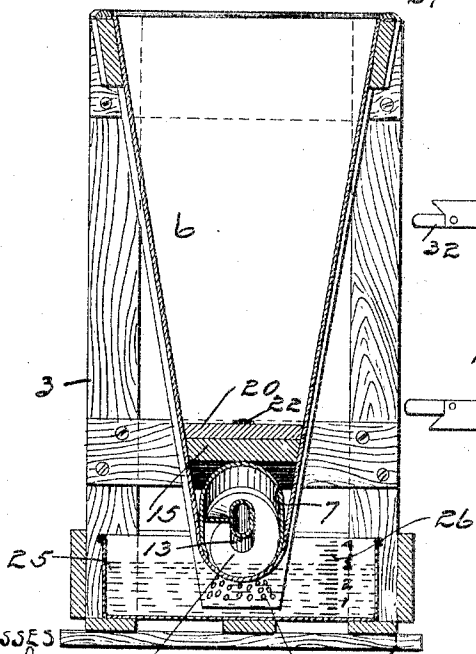

FIG. 4. 10
x-x

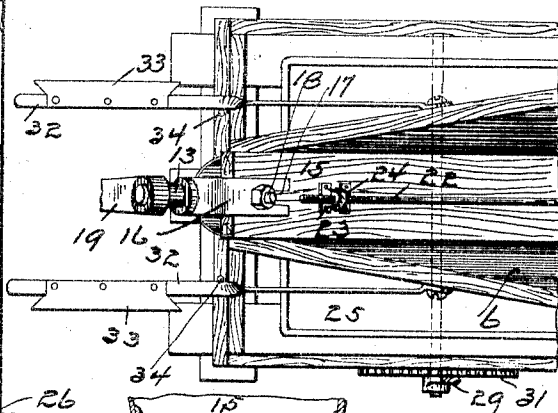

FIG. 5

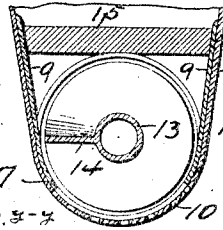

FIG. 6. 8-8

WITNESSES

M. M. Amio
M. H. Harty

INVENTOR
ANDREW V. CLELAND
BY Paul H. Paul
HIS ATTORNEYS

No. 776,889.

PATENTED DEC. 6, 1904.

A. V. CLELAND.
SMUT MACHINE.

APPLICATION FILED APR. 8, 1904.

NO MODEL.

3 SHEETS—SHEET 3.

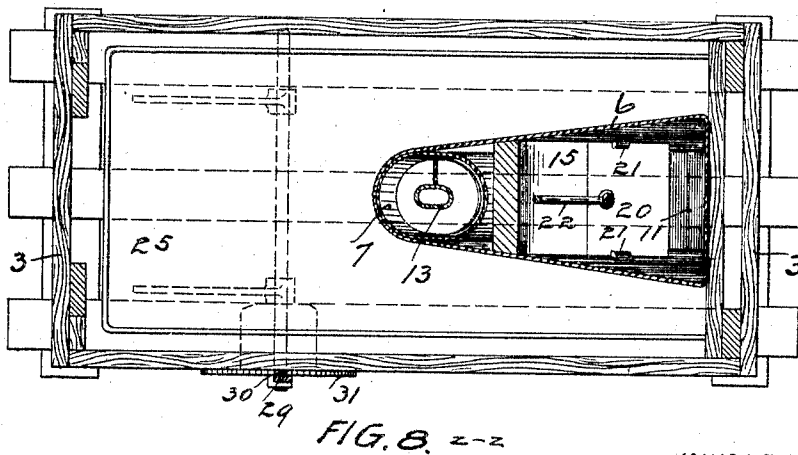
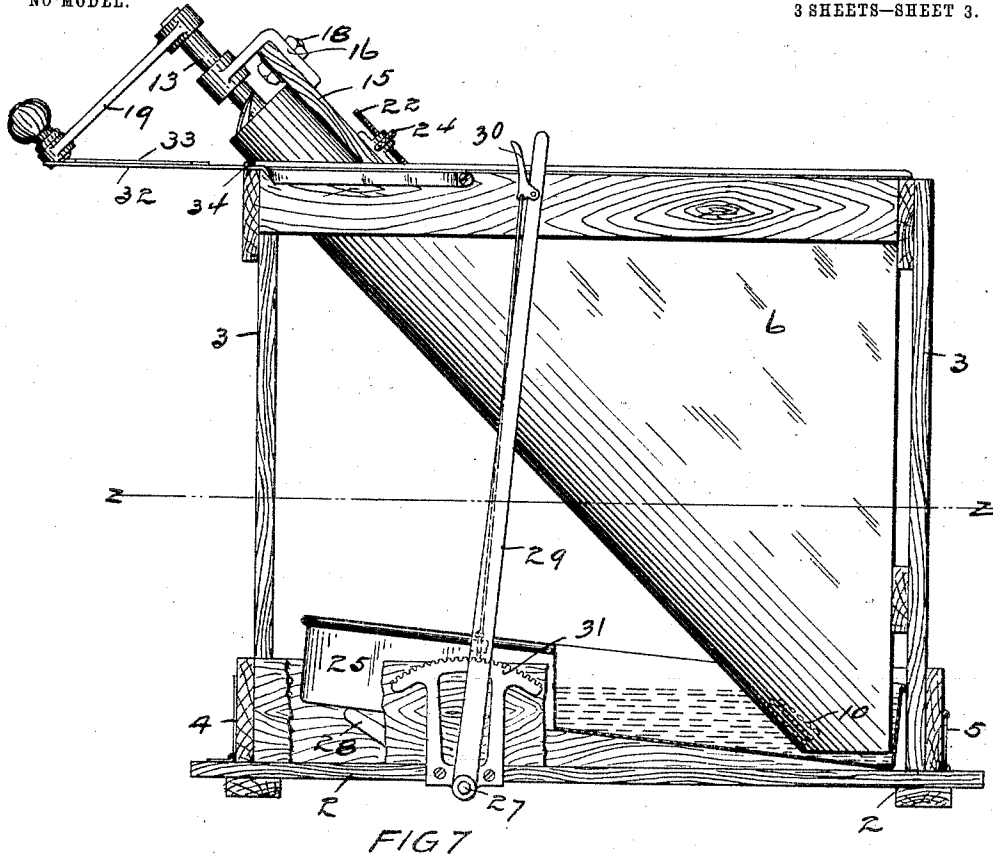

WITNESSES
M. M. Lewis
M. Hagerty

INVENTOR
ANDREW V. CLELAND
BY *Paul H. Paul*
ATTORNEYS

UNITED STATES PATENT OFFICE.

ANDREW V. CLELAND, OF MINNEAPOLIS, MINNESOTA.

SMUT-MACHINE.

SPECIFICATION forming part of Letters Patent No. 776,889, dated December 6, 1904.

Application filed April 8, 1904. Serial No. 202,165. (No model.)

To all whom it may concern:

Be it known that I, ANDREW V. CLELAND, of Minneapolis, Hennepin county, Minnesota, have invented certain new and useful Improvements in Smut-Machines, of which the following is a specification.

My invention relates to machines for treating wheat, oats, and other grains for the purpose of removing or destroying the smut fungus growth or germ. In machines of this kind as usually constructed the grain is delivered to a tank containing a chemically-prepared water and allowed to settle therein and become thoroughly saturated with the solution and is finally removed by means of a carrier-belt. This method of treating the grain has been found objectionable, as it not only becomes more thoroughly soaked with the solution than is necessary to produce the desired result, but some portions remaining in the tank longer than others produces uneven saturation, and when the grain is delivered to the carrier it is so thoroughly soaked that it is heavy and difficult to handle and requires considerable effort on the part of the operator to lift it out of the machine. Furthermore, the grain absorbs more solution than is necessary, and consequently requires a longer time to dry after being removed from the tank.

The object, therefore, of my invention is to provide an apparatus wherein uniform absorption of the solution can be obtained and excessive saturation of the grain prevented.

A further object is to provide an apparatus wherein the distribution of the solution and the percentage of the grain exposed to obtain the desired degree of moisture can be easily and quickly regulated according to the kind and condition of the grain.

Other objects of the invention will appear from the following detailed description.

The invention consists generally in providing separate tanks or receptacles for the grain and solution with means for regulating the quantity of liquid to which the grain is exposed according to its kind and condition.

Further, the invention consists in improved means for elevating the grain out of its tank or receptacle.

Further, the invention consists in various

constructions and combinations, all as hereinafter described, and particularly pointed out in the claims.

In the accompanying drawings, forming part of this specification, Figure 1 is a side elevation of a smut-machine embodying my invention. Fig. 2 is an end elevation of the same. Fig. 3 is a vertical longitudinal section. Fig. 4 is a vertical transverse section on the line *xx* of Fig. 3. Fig. 5 is a plan view of one end of the machine. Fig. 6 is a section on the line *yy* of Fig. 3. Fig. 7 is a vertical section showing the solution-receptacle in its tilted position. Fig. 8 is a horizontal section on the line *yy* of Fig. 3.

In the drawings, 2 represents a suitable base whereon the frame 3 of the machine is arranged. I prefer to provide hinges 4 at one end of the machine-frame, connecting it with the base 2, and a locking device 5 at the other end. This arrangement allows the convenient tilting of the machine-frame to permit access to the solution receptacle or pan beneath. Within the frame I arrange a sheet-metal grain receptacle or tank 6, substantially wedge-shaped in form and extending diagonally across the frame from one lower corner to the opposite corner at the top of the machine. A pipe 7, preferably cylindrical in form, is arranged in the bottom of said tank at an angle of about forty-five degrees and provided at its lower end with an opening 8, formed by cutting the pipe at that point and turning back the flaps 9 and securing them to the sides of the tank, the inclination of the flaps serving to direct the grain into the pipe. A series of perforations 10 are provided in the walls of the pipe and tank opposite the feed-opening 8. A triangular block 11 is provided in the lower end of the tank, to which the corresponding end of the pipe 7 is secured. A cone-bearing 12 is mounted on said block and adapted to enter the open lower end of a hollow shaft 13, arranged within said pipe and provided with a spiral web 14, which with said shaft forms an inclined screw conveyer.

A plank 15 fits snugly between the walls of the tank 6 over the pipe 7 and is provided at its upper end with a bracket 16, having a bearing for said shaft 13 and detachably se-

cured to said plank by means of a slot 17 and bolt 18. By disconnecting the bracket from the plank the shaft can be easily detached from the machine and any grain that may remain in the tank or pipe removed. The cone-bearing at the bottom of the pipe permits the convenient centering of the shaft therein when the parts are assembled. A suitable operating-crank 19 is provided on the outer end of the shaft.

To regulate the flow of grain through the opening 8, I provide a slide 20, operating on the plank 15 between guides 21 and having a threaded rod 22, that is movable in the bracket 23 by means of an adjusting-nut 24. This nut is located within convenient reach of the operator, and by manipulating the same the feed of grain to the conveyer is easily regulated.

The motion of the grain in the screw conveyer insures the distribution of the moisture throughout the mass as it is being elevated, even if only a portion of the grain contacts with the solution at the bottom of the elevator-pipe, and taking advantage of this fact I provide a shallow metallic pan 25 beneath the grain-tank, having walls that extend above the level of the perforations in the pipe 7 and adapted to deliver the solution through said perforations to the grain as it falls through the opening 8 into the conveyer-pipe. The height of the liquid in the pan necessarily regulates the amount that passes through the perforations and the percentage of the grain that is moistened upon its delivery to the pipe. If the grain is in a very smutty condition, it will be desirable to moisten a larger percentage of it than if it is comparatively free from smut, and the operator knowing the condition of the grain and the kind that is being treated can easily control the distribution of the moisture thereto. In some cases it will only be necessary to moisten, say, one-fourth of the feed to the conveyer-pipe, the remaining portion being moistened by absorption through the action of the screw conveyer. By simply varying the depth of the liquid in the pan the operator can control the moistening of the grain-kernels. In this way excessive saturation is avoided, the grain is nearly dry, though thoroughly treated before its delivery to the top of the machine, and considerable saving is effected in the use of the solution.

In handling certain kinds of grain—for instance, flax—oversaturation is extremely dangerous, as it is liable to form a pulpy mass and render it unfit for seed. In other grains, such as oats, the smut is found beneath the outer husk, and the rolling and tumbling of the kernels and the contact of the dry with the wet kernels in passing from the bottom to the top of the conveyer are just what is required to destroy the smut-germ.

To enable the operator to determine the proper height of the liquid in the pan, I pre-

fer to provide marks on the end of the pan, (indicated at 26 in Fig. 4,) and to avoid the use of an unnecessary amount of solution I prefer to provide means for tilting the pan to cause the solution to flow therein toward the receiving end of the conveyer-pipe. This tilting means consists of a shaft 27, mounted on the base 2 beneath the pan and having arms 28, that engage the bottom of the pan, and an operating-lever 29, provided with a latch 30 to engage a quadrant 31, secured on the base of the machine. By means of this tilting mechanism the operator can easily and quickly elevate or depress one end of the pan and regulate the height of the liquid around the perforations in the conveyer-pipe according to the volume of grain that he desires to moisten.

I prefer to provide a bag-support beneath the discharge end of the conveyer-pipe, consisting of arms 32, pivoted on the side of the grain-tank and arranged to rest in a horizontal position upon the machine-frame and having plates 33 with pointed ends to engage the top of the sack. Pins 34 are provided in the machine-frame, against which the arms bear when pressed toward each other. The arms are drawn together when placing a sack thereon and when released will fly out and hold the sack securely.

I claim as my invention—

1. In a smut-machine, the combination, with a grain-tank having a series of perforations in its bottom, of a conveyer-pipe arranged at an incline within said tank and having a feed-opening at its lower end and perforations opposite said opening coinciding with the perforations in said tank, a screw conveyer operating within said pipe, and a shallow pan wherein the lower end of said tank and pipe is suspended and mechanism for tilting said pan to increase or decrease the flow of liquid through said perforations, for the purpose specified.

2. In a smut-machine, the combination, with a grain-tank having perforations in its lower walls, of a conveyer-pipe arranged at an incline in the bottom of said tank and having a feed-opening on one side and perforations on the opposite side coinciding with the perforations in said tank, the upper walls of said tank and pipe being imperforate, an elevating device within said pipe, means for regulating the flow of grain through said feed-opening, and a shallow solution-tank wherein the perforated portions of said grain-tank and pipe are suspended, substantially as described.

3. In a smut-machine, the combination, with a frame, of a grain-tank triangular in form having side walls that converge toward the bottom, a conveyer-pipe arranged at an incline in the bottom of said tank and having a feed-opening in its lower end, the lower walls of said tank and said pipe having perforations opposite said feed-opening, a screw conveyer operating in said pipe, a shallow pan having

a flat bottom adapted to contain a liquid wherein the lower perforated portions of said tank and said pipe are suspended, and mechanism for tilting said pan to increase or decrease the flow of liquid through said perforations and the quantity of grain affected thereby, substantially as described.

4. In a smut-machine, the combination, with an inclined grain-conveyer pipe and a screw conveyer operating therein, said pipe having a feed-opening at its lower end and a series of perforations, a grain-receptacle arranged to deliver grain to said feed-opening, a pan adapted to contain a solution wherein the perforated portion of said pipe is suspended, and mechanism for tilting said pan to increase or decrease the depth of the liquid therein and its passage through said perforations.

5. In a smut-machine, the combination, with a grain-tank having an inclined bottom wall provided with perforations near its lower end, of a conveyer-pipe arranged at an incline on the bottom of said tank and having a closed lower end and a feed-opening in its upper side near said end, and a series of perforations in its under side coinciding with the perforations in the bottom of said tank, a solution-pan wherein the perforated portions of said grain-tank and conveyer-pipe are suspended, the bottom walls of said tank and conveyer-pipe above said solution-pan being imperforate, a screw conveyer provided within said pipe, and means for revolving said conveyer, substantially as described.

6. In a smut-machine, the combination, with a frame, of a grain-tank having an inclined bottom and side walls flaring outwardly therefrom, a pipe fitting said bottom and having a feed-opening near its lower end, said pipe and

the bottom of said tank being provided with a series of perforations arranged to coincide with one another, a plate provided over said pipe between said flaring walls and having an opening near its lower end coinciding substantially with the feed-opening in said pipe, a screw conveyer operating within said pipe, and a pan adapted to contain a liquid solution and wherein the perforated portions of said pipe and tank are suspended, substantially as described.

7. In a smut-machine, the combination, with a suitable base, of a shallow solution-pan supported thereon, a frame hinged at one end of said base over said pan, means for temporarily locking the other end of said frame to said base, a grain-tank mounted in said frame, an elevating device therein, the lower portion of said tank being normally suspended within said pan and communicating therewith, for the purpose specified.

8. In a smut-machine, the combination, with a grain-tank, of a conveyer-pipe arranged at an incline therein and having a feed-opening, a plank fitting within the walls of said tank over said pipe, a slide thereon arranged to regulate the feed of grain through said opening, a screw conveyer operating within said pipe, and a solution-receptacle communicating with said tank and pipe and arranged to deliver liquid thereto, for the purpose specified.

In witness whereof I have hereunto set my hand this 2d day of April, 1904.

ANDREW V. CLELAND.

In presence of—
RICHARD PAUL,
M. HAGERTY.