



(12) **EUROPEAN PATENT APPLICATION**

(88) Date of publication A3:  
**09.03.2022 Bulletin 2022/10**

(51) International Patent Classification (IPC):  
**F23D 14/58<sup>(2006.01)</sup>**

(43) Date of publication A2:  
**22.12.2021 Bulletin 2021/51**

(52) Cooperative Patent Classification (CPC):  
**F23D 14/58; F23D 2203/1012; F23D 2203/102**

(21) Application number: **21178907.8**

(22) Date of filing: **11.06.2021**

(84) Designated Contracting States:  
**AL AT BE BG CH CY CZ DE DK EE ES FI FR GB GR HR HU IE IS IT LI LT LU LV MC MK MT NL NO PL PT RO RS SE SI SK SM TR**

(71) Applicant: **Beckett Thermal Solutions**  
**North Ridgeville, OH 44039 (US)**

(72) Inventor: **O'DONNELL, Michael J.**  
**Avon, OH 44011 (US)**

(30) Priority: **16.06.2020 US 202063039744 P**

(74) Representative: **Frenkel, Matthias Alexander**  
**Wuesthoff & Wuesthoff**  
**Patentanwälte PartG mbB**  
**Schweigerstraße 2**  
**81541 München (DE)**

(60) Divisional application:  
**22150730.4**

(54) **PORTED BURNER**

(57) A fuel burner includes a tube extending along a centerline from a first end to a second end and having an outer surface and an inner surface defining a central passage. The central passage is supplied at the first end with a mixture of air and combustible fuel pre-mixed upstream of the tube. The second end is closed by an end

wall in a fluid-tight manner. The tube has fluid directing structure for directing the pre-mixed mixture radially outward from the central passage to an exterior of the tube such that flames exiting adjacent fluid directing structures extend towards and impinge one another.

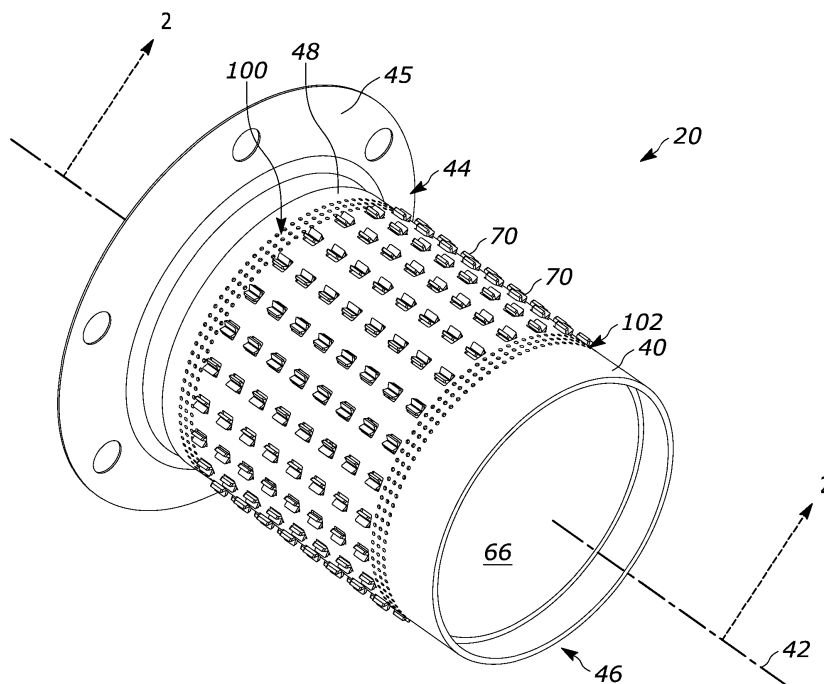

**FIG. 1**



**PARTIAL EUROPEAN SEARCH REPORT**

Application Number

under Rule 62a and/or 63 of the European Patent Convention.  
This report shall be considered, for the purposes of subsequent proceedings, as the European search report

**EP 21 17 8907**

**DOCUMENTS CONSIDERED TO BE RELEVANT**

Category	Citation of document with indication, where appropriate, of relevant passages	Relevant to claim	CLASSIFICATION OF THE APPLICATION (IPC)
X	US 2015/167967 A1 (LE MER JOSEPH [FR]) 18 June 2015 (2015-06-18)	1, 5, 6, 8	INV. F23D14/58
A	* paragraph [0049] - paragraph [0114]; figures 1-5, 9 *	4, 7	
X	WO 2015/196504 A1 (SMITH A O CHINA WATER HEATER [CN]) 30 December 2015 (2015-12-30)	1-3, 5, 6, 8	
A	* page 3, line 16 - page 6, line 1; figures 1-4 *	4, 7	
Y	DE 10 2015 202983 A1 (BOSCH GMBH ROBERT [DE]) 25 August 2016 (2016-08-25)	1, 5, 6, 8	
A	* paragraph [0027] - paragraph [0076]; figures 2-4, 7 *	4, 7	
Y	US 2010/291495 A1 (SCRIBANO GIANFRANCO [IT] ET AL) 18 November 2010 (2010-11-18)	1, 5, 6, 8	
A	* paragraph [0018] - paragraph [0036]; figures 1-3 *	4, 7	
Y	EP 1 840 461 A1 (AEROMATIX LTD [GB]) 3 October 2007 (2007-10-03)	1, 5, 6, 8	TECHNICAL FIELDS SEARCHED (IPC)
A	* paragraph [0014] - paragraph [0031]; figures 1-5 *	4, 7	F23D

**INCOMPLETE SEARCH**

The Search Division considers that the present application, or one or more of its claims, does/do not comply with the EPC so that only a partial search (R.62a, 63) has been carried out.

Claims searched completely :

Claims searched incompletely :

Claims not searched :

Reason for the limitation of the search:

**see sheet C**

Place of search

**Munich**

Date of completion of the search

**31 January 2022**

Examiner

**Theis, Gilbert**

**CATEGORY OF CITED DOCUMENTS**

X : particularly relevant if taken alone  
Y : particularly relevant if combined with another document of the same category  
A : technological background  
O : non-written disclosure  
P : intermediate document

T : theory or principle underlying the invention  
E : earlier patent document, but published on, or after the filing date  
D : document cited in the application  
L : document cited for other reasons  
.....  
& : member of the same patent family, corresponding document

1  
EPO FORM 1503 03:82 (P04E07)



**INCOMPLETE SEARCH  
SHEET C**

Application Number  
**EP 21 17 8907**

5

**Claim(s) completely searchable:**  
1-8

10

**Claim(s) not searched:**  
9-15

**Reason for the limitation of the search:**

15

The search has been restricted to the subject-matter indicated by the applicant in his letter of 28.12.2021 filed in reply to the invitation pursuant to Rule 62a(1) EPC. Hence, the search report has been drawn up on the basis of claims 1 to 8.

20

25

30

35

40

45

50

55

ANNEX TO THE EUROPEAN SEARCH REPORT  
ON EUROPEAN PATENT APPLICATION NO.

EP 21 17 8907

5

This annex lists the patent family members relating to the patent documents cited in the above-mentioned European search report. The members are as contained in the European Patent Office EDP file on The European Patent Office is in no way liable for these particulars which are merely given for the purpose of information.

31-01-2022

10

15

20

25

30

35

40

45

50

55

Patent document cited in search report	Publication date	Patent family member(s)	Publication date
US 2015167967 A1	18-06-2015	CA 2877803 A1	09-01-2014
		CN 104541103 A	22-04-2015
		EP 2870410 A1	13-05-2015
		FR 2993040 A1	10-01-2014
		JP 6193984 B2	06-09-2017
		JP 2015525864 A	07-09-2015
		KR 20150037945 A	08-04-2015
		RU 2015102065 A	27-08-2016
		US 2015167967 A1	18-06-2015
		WO 2014006103 A1	09-01-2014
WO 2015196504 A1	30-12-2015	CN 104048296 A	17-09-2014
		CN 204006008 U	10-12-2014
		WO 2015196504 A1	30-12-2015
DE 102015202983 A1	25-08-2016	DE 102015202983 A1	25-08-2016
		WO 2016131807 A1	25-08-2016
US 2010291495 A1	18-11-2010	CN 101861496 A	13-10-2010
		EP 2227655 A1	15-09-2010
		US 2010291495 A1	18-11-2010
		WO 2009065733 A1	28-05-2009
EP 1840461 A1	03-10-2007	NONE	

EPO FORM P0459

For more details about this annex : see Official Journal of the European Patent Office, No. 12/82