

No. 617,989.

Patented Jan. 17, 1899.

W. MADISON.
SASH LOCK AND ALARM.

(Application filed Aug. 19, 1898.)

(No Model.)

2 Sheets—Sheet 1.

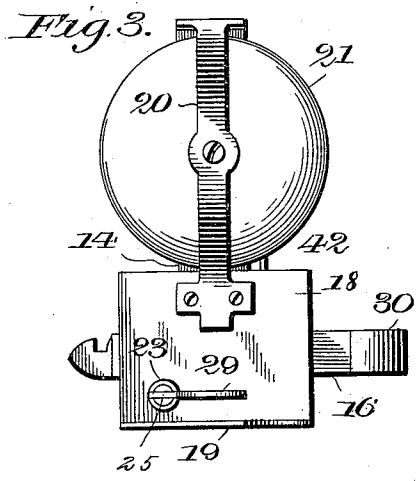
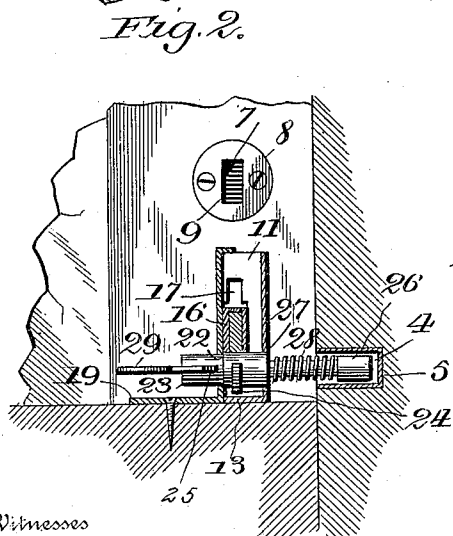
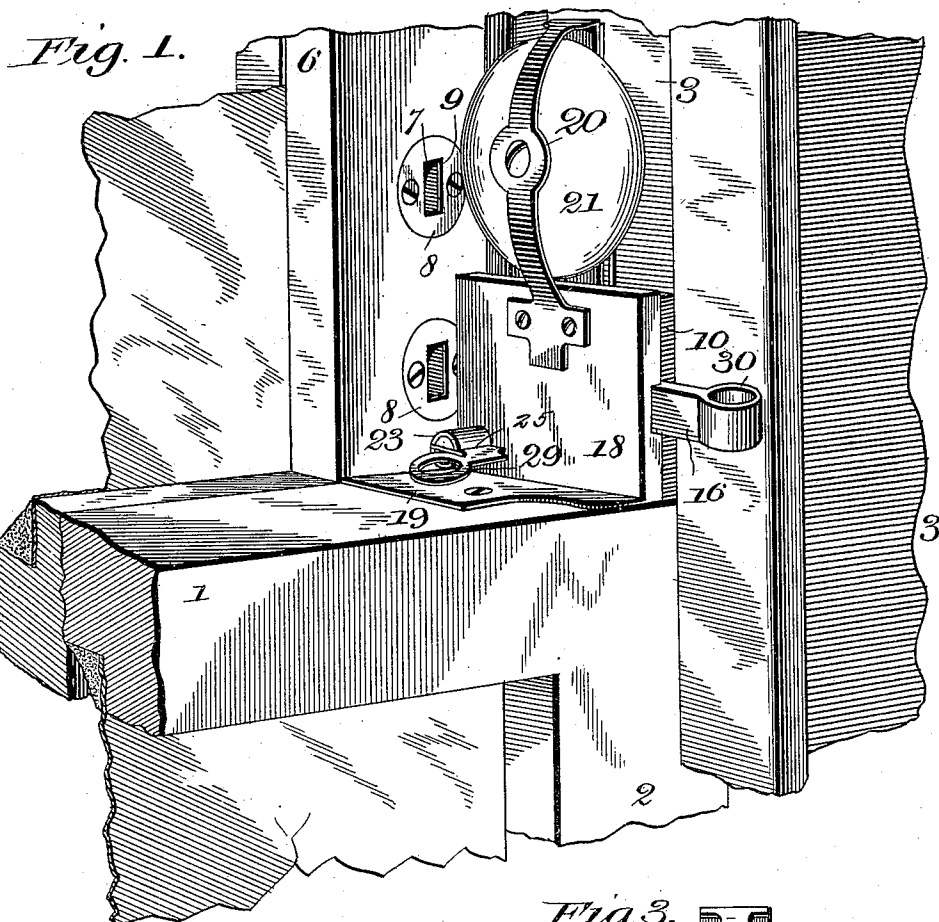

Witnesses
L. C. Mills.
H. L. Amer.

Inventor:
William Madison,
 by *V. D. Stockbridge*
 his Attorney

No. 617,989.

Patented Jan. 17, 1899.

W. MADISON.
SASH LOCK AND ALARM.

(Application filed Aug. 19, 1898.)

(No Model.)

2 Sheets—Sheet 2

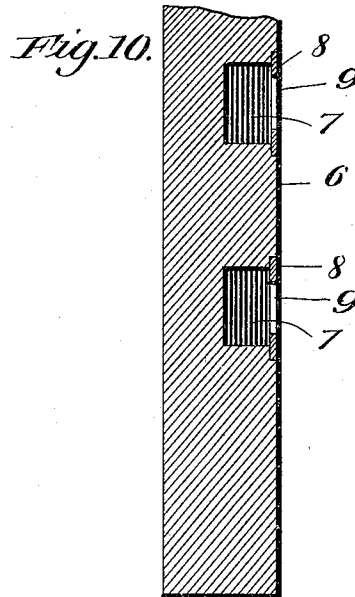
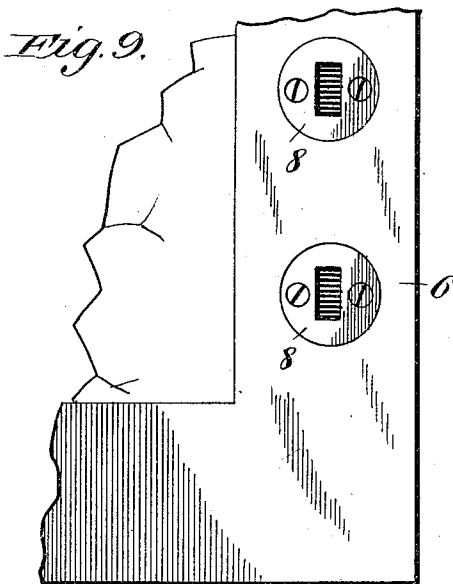
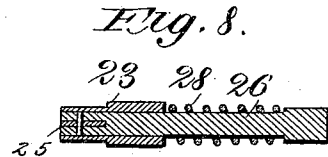
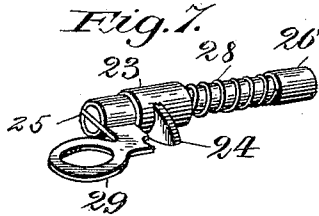
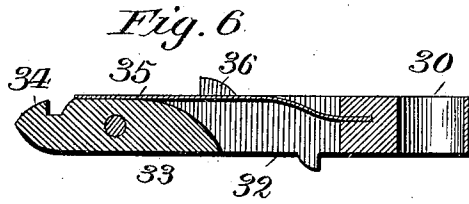
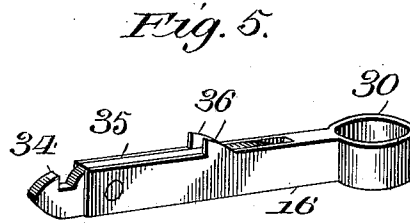
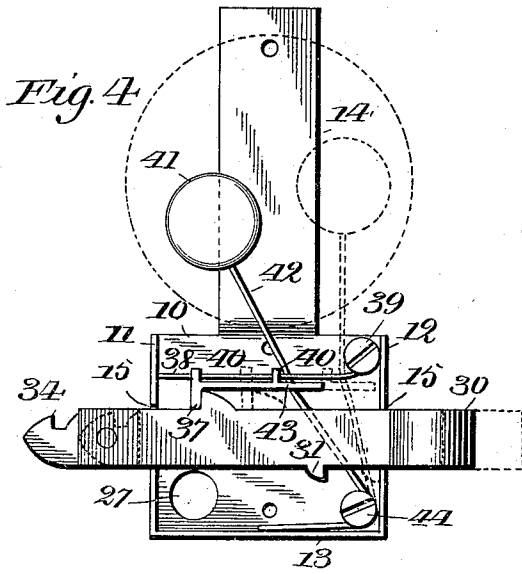

Witnesses

L. C. Hills.
H. L. Ames.

Inventor

William Madison
by V. S. Stockbridge
his Attorney.

UNITED STATES PATENT OFFICE.

WILLIAM MADISON; OF LOS GATOS, CALIFORNIA, ASSIGNOR OF ONE-HALF
TO THOMAS SAMUEL COMDEN, OF SAME PLACE.

SASH-LOCK AND ALARM.

SPECIFICATION forming part of Letters Patent No. 617,989, dated January 17, 1899.

Application filed August 19, 1898. Serial No. 689,016. (No model.)

To all whom it may concern:

Be it known that I, WILLIAM MADISON, a citizen of the United States, residing at Los Gatos, in the county of Santa Clara and State of California, have invented certain new and useful Improvements in Sash-Locks and Alarms; and I do hereby declare the following to be a full, clear, and exact description of the invention, such as will enable others skilled in the art to which it appertains to make and use the same.

My invention relates to sash-locks and alarms, the objects of the same being to provide means whereby the two sashes of a window may be firmly and securely locked together, means whereby one or both of the sashes may be locked in partially open position for ventilating purposes, means whereby the two sashes will be held in close contact one with the other for preventing rattling and the entrance of wind or dust from without, and an alarm which will be actuated by the upward movement of the lower sash or the downward movement of the upper sash.

The invention consists of a longitudinally-movable locking-bolt mounted upon one of the sashes and outwardly spring-pressed, formed with an engaging portion upon its forward end, which is adapted to be inserted into one of a series of sockets in the other sash.

The invention also consists of a longitudinally-movable locking-bolt, a pivotally-mounted catch on the forward end thereof having a hooked engaging portion, a gong, a hammer whose spring is energized by the forward movement of the locking-bolt in the act of locking the sashes, a releasing-dog therefor engaging a tooth or projection on said locking-bolt and lying within the path of pivotal movement of the catch on said bolt, and a key for swinging said catch.

The invention also consists in other details of construction and combinations of parts, which will be hereinafter more fully described and claimed.

In the drawings forming a part of this specification, Figure 1 represents a perspective view of two sashes, showing my improved lock and alarm applied thereto. Fig. 2 is a vertical section through the window-frame and

the lock-casing, the same intersecting the key-bolt, by means of which the lower sash is locked to the casing, and the sockets in the latter. Fig. 3 is a front elevation of the device. Fig. 4 is a similar view with the front of the lock-casing, including the gong (the latter being shown in dotted lines) and the supplemental locking-bolt which are carried thereby, removed, the main locking-bolt being shown in full lines in one position and in dotted lines in its other position. Fig. 5 is a detail perspective view of the locking-bolt. Fig. 6 is a vertical central longitudinal section through the same. Fig. 7 is a detail perspective view of the key and the spring-actuated key-bolt extending therethrough. Fig. 8 is a longitudinal section through the same. Fig. 9 is a detail view of the side rail of the upper sash, showing the sockets and socket-plates therein. Fig. 10 is a section through the same.

Like reference-numerals indicate like parts in the different views.

Upon the meeting-rail 1 of the lower sash 2, adjacent to one end thereof, is secured, by screws or otherwise, the casing containing the operating mechanism of the lock and alarm. The window-casing 3, adjacent to the side rails of the lower sash 2, is formed with a series of sockets 4 4, provided with thimbles 5, for a purpose which will hereinafter appear. One of the side rails of the upper sash 6 is formed with a series of sockets or recesses 7 in its front face, which are covered by protecting-plates 8 8, screwed or otherwise secured in place and provided with elongated slots 9, which are of slightly smaller dimensions than said sockets or recesses, the plates thereby providing within said sockets shoulders or engaging portions, for a purpose to be hereinafter set forth.

The casing in which the operative parts of the device are located is formed in two sections, the section 10, which may be termed the "back" of the casing, having side flanges 11 12 thereon and a bottom flange 13. It is also formed with an upwardly-extending arm 14. Both of the side flanges 11 and 12 are slotted, as shown at 15, for the reception of the locking-bolt 16, and the forward side flange 11 has a supplemental slot or opening

17, communicating with the slot 15 and of slightly smaller dimensions. The other section 18 of the casing may be termed the "front" and consists of a plate having an outwardly-extending bottom flange 19, by means of which the casing is secured to the sash 2. These two sections or members of the locking-casing are suitably secured together by screws, rivets, or other analogous devices. Extending upwardly from the front plate 18 is a supporting-arm 20, to which is secured at a point intermediate of its ends a gong 21. The said front plate is further provided with a circular opening 22 for the reception of the key 23, which consists of a sleeve having a laterally-extending arm or engaging portion 24 thereon and provided with a diametrical slot 25 in its outer end. The key-bolt or supplemental locking-bolt 26 extends through the tubular key 23 and projects through an opening 27 in the back section 10 of the casing. Surrounding the supplemental locking-bolt 26 is a coil-spring 28, which engages at one end a shoulder on said bolt and at its other end the key itself. The forward end of the supplemental bolt has secured to it a flat handle or finger-engaging portion 29, by means of which said bolt may be drawn outwardly, and said key may be turned when said handle is located within the diametrical slot in said key. When in its normal position, the supplemental or auxiliary locking-bolt 26 projects beyond the side of the sash 2 and fits within one or the other of the sockets 4 in the window-frame 3 and locks the lower sash 2 against upward or downward movement.

The locking-bolt 16 is adapted to slide longitudinally in the casing, the same being guided in its movements by the slots 15, in which it is located. Said bolt is formed upon its outer end with a ring or finger-engaging portion 30 and has upon its lower side a lug or projection 31, which serves to limit the outward movement thereof in the casing. The same is formed with a longitudinally-extending slot 32, between which is located a catch 33, which is pivoted to the bolt and has a notched or hooked outer end 34, as clearly shown. Secured to the bolt 16 and engaging the upper side of the catch 33 is a flat spring 35. Upon the upper side of the bolt 16 are lugs or engaging portions 36, which are engaged by a sliding dog 37, mounted upon one arm of a spring 38, which is coiled upon a post 39 on the back of the casing. Said dog is normally urged downwardly into contact with the bolt 16 by said spring. The spring itself passes through eyes in flanges 40 40, formed on said dog, which eyes serve as guides. The hammer or striker 41 of the gong 21 is secured to the upper end of a spring-arm 42, which passes through an eye 43 in the sliding dog 37 and is coiled upon a post 44 in the back of the casing. The action of the spring-arm 42 is to urge or hold the hammer or striker 41 in its outer position in contact with the gong.

The operation of the device is as follows:

When it is desired to lock the two sashes together, the locking-bolt 16 is forced inwardly against the action of the spring 42, which is exerted on said bolt through the sliding dog 37 and the lugs 36 on the upper side of the bolt. In this movement the pivotally-mounted catch 33 passes into one of the sockets 7 in the upper sash 6, and the hooked end of said catch engages the shoulders formed by the plates 8. The said locking-bolt is thereby held in its inward position and serves to draw the sashes 2 and 6 in contact with each other, thereby preventing the ingress of dust or wind from without. It will be obvious that for ventilating purposes the catch 33 upon the locking-bolt 16 may be inserted into any one of the sockets 7 and the two sashes locked in slightly-separated positions. If now any unauthorized attempt be made to open the sashes from without either by raising the lower sash or by lowering the upper sash, the action upon the pivoted catch 33 will be to draw downwardly the outer end thereof. This will force upwardly the inner end of said catch against the action of the spring 35, elevate the sliding dog 37, release the same from its engagement with the lugs or projections 36, and permit said dog and the hammer 41 to be projected outwardly into contact with the gong 21, giving an alarm. Even after the alarm is given, however, the locking-bolt 16 will remain in its locking position, as the movement of the sash does not affect the movement of the bolt. In order to unlock the two sashes one from the other, the key 23 is turned upwardly and forwardly by means of the handle 29, which fits within the diametrical slot 25 in said key. This action causes the laterally-extending arm 24 on said key to engage the rear under side of the pivoted catch 33, which lowers the outer end of said catch and disengages the hooked portion thereof from the slot 9 in the plate 8. The locking-bolt 16 is then free to be drawn rearwardly by means of the ring or finger engaging portion 30.

The above description relates solely to the locking mechanism between the two sashes and the means for actuating the alarm by a movement of said sashes. As heretofore stated, however, means have been provided for locking the lower sash 2 to the window-frame independent of the locking mechanism between the two sashes themselves. This consists of the auxiliary locking-bolt 26, which projects through the opening 27 in the back of the casing and into one or the other of the thimbles 5 in the sockets 4. By drawing outwardly upon the handle 29 said auxiliary locking-bolt may be released and the lower sash moved up or down. By means of this auxiliary locking mechanism the two sashes may be locked in any desired positions relative one to the other—that is to say, the lower sash may be partially raised and locked to the window-frame 3 and the upper sash may

be partially lowered and locked to the lower sash 2 for ventilating purposes, or the lower sash may be completely closed and the upper sash partially lowered, or the lower sash may be partially raised and the upper sash completely closed.

The present embodiment of my invention is now deemed by me to be preferable; but it is obvious that minor changes may be made therein without departing from the nature or spirit thereof. For example, the auxiliary locking mechanism might be dispensed with altogether or the gong and the striking mechanism therefor might be done away with. In the latter case it would be preferable to have the upper end of the casing in which the operative parts are mounted closed.

Having now described the invention, what I claim as new, and desire to secure by Letters Patent, is—

1. A sash-lock comprising a longitudinally-movable outwardly-spring-pressed locking-bolt on one of the sashes, a pivotally-mounted catch thereon having a hooked engaging portion, coacting mechanism on the other of the sashes with which said catch engages, means for moving said bolt and catch longitudinally, and independent means for swinging said catch on its pivotal connection with the bolt, as and for the purpose set forth.

2. A sash-lock comprising a longitudinally-movable locking-bolt, alarm-actuating mechanism energized by the movement of said bolt, and releasing mechanism actuated by the movement of one of the sashes.

3. A sash-lock comprising a longitudinally-movable locking-bolt, alarm-actuating mechanism, energized by the movement of said bolt, and a trip for releasing said alarm-actuating mechanism thrown into operation by the movement of one of the sashes.

4. A sash-lock comprising a longitudinally-movable bolt, a pivotally-mounted catch upon the forward end thereof, alarm-actuating mechanism, and a sliding dog connected therewith engaging said bolt and lying within the path of pivotal movement of said catch, as and for the purpose set forth.

5. A sash-lock comprising a longitudinally-movable bolt upon one of the sashes, a pivotally-mounted catch on said bolt, coacting mechanism upon the other of the sashes with which said bolt engages, and alarm mechanism comprising a spring-actuated hammer, and a sliding dog operatively connected therewith engaging the lug on said bolt and lying within the path of pivotal movement of said catch.

6. A sash-lock comprising a longitudinally-movable locking-bolt on one of the sashes, a

pivotally-mounted catch upon the forward end thereof, coacting mechanism on the other of the sashes with which said catch engages, and alarm mechanism comprising a hammer, a spring to which said hammer is secured, a slidingly-mounted dog, and a spring to which said dog is connected, the said dog being operatively connected to the hammer-spring and engaging projections on said bolt.

7. A sash-lock comprising a casing secured to one of the sashes, a longitudinally-movable bolt in said casing having a lug or projection thereon, a pivotally-mounted catch upon the forward end of said bolt having a hooked engaging portion, a spring for holding said catch in locking position, cooperating mechanism on the other of the sashes with which said catch engages, in combination with a gong, a hammer therefor, a spring-arm to which said hammer is attached, secured to said casing, a slidingly-mounted dog engaging the lug or projection on said bolt and provided with an opening through which said spring-arm passes, and a spring for said dog secured to said casing and provided with an arm which extends through guide-openings in said dog and tends to normally hold said dog in engagement with said lug at a point adjacent to the rear end of said pivotally-mounted catch.

8. In a sash-lock, a locking-bolt cooperating with the two sashes, a key for releasing said bolt, and an auxiliary locking-bolt extending through said key and adapted to fit within sockets in the window-frame.

9. In a sash-lock, a casing secured to one of the sashes, a locking-bolt longitudinally movable in said casing, a pivotally-mounted catch on said bolt, cooperating mechanism on the other of the sashes with which said catch engages, a spring for normally holding said catch in locking position, a rotatably-mounted hollow key for swinging said catch in opposition to its spring for releasing it from locking position, the said key having a diametrical slot, in its outer end, an auxiliary locking-bolt extending through said key, a spring for normally holding said auxiliary bolt in locking engagement with the window-frame, and a handle upon the outer end of said auxiliary bolt adapted to fit within the slot in said key, as and for the purpose set forth.

In testimony whereof I affix my signature in presence of two witnesses.

WILLIAM MADISON.

Witnesses:

A. NICHOLSON,
W. PECK.