

May 2, 1950

H. W. HEMPEL ET AL  
CIRCULAR STENCIL FEEDING ATTACHMENT

2,506,423

Filed July 13, 1946

2 Sheets-Sheet 1

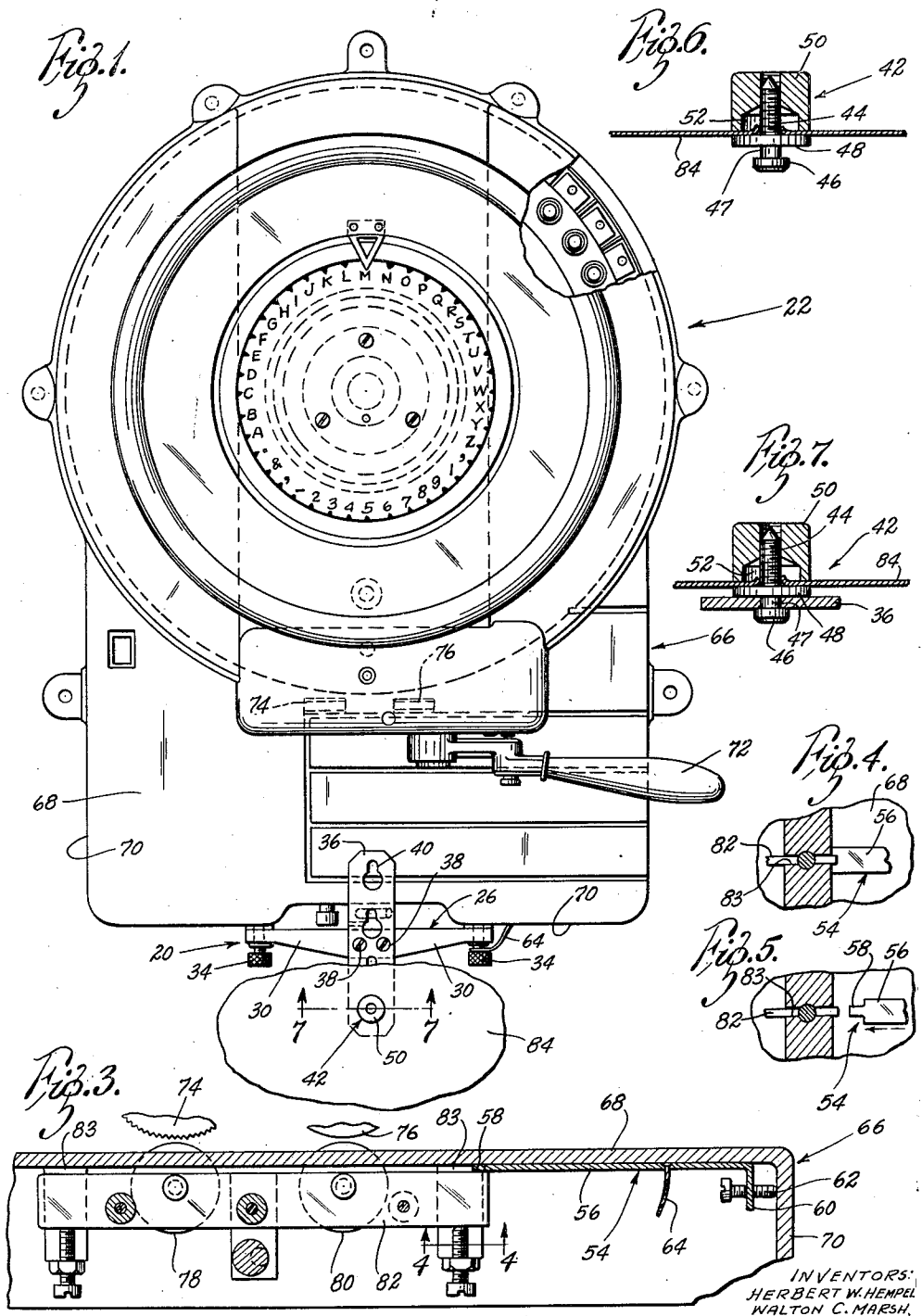

INVENTORS:  
HERBERT W. HEMPEL  
WALTON C. MARSH,  
BY Kingsland, Rogers & Egell  
ATTORNEYS.

May 2, 1950

H. W. HEMPEL ET AL

2,506,423

CIRCULAR STENCIL FEEDING ATTACHMENT

Filed July 13, 1946

2 Sheets-Sheet 2

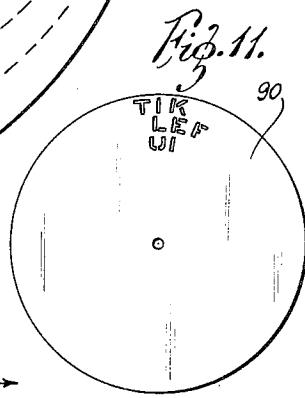
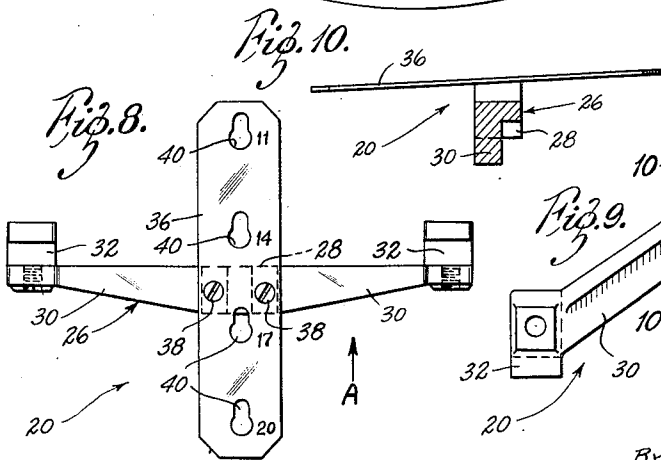
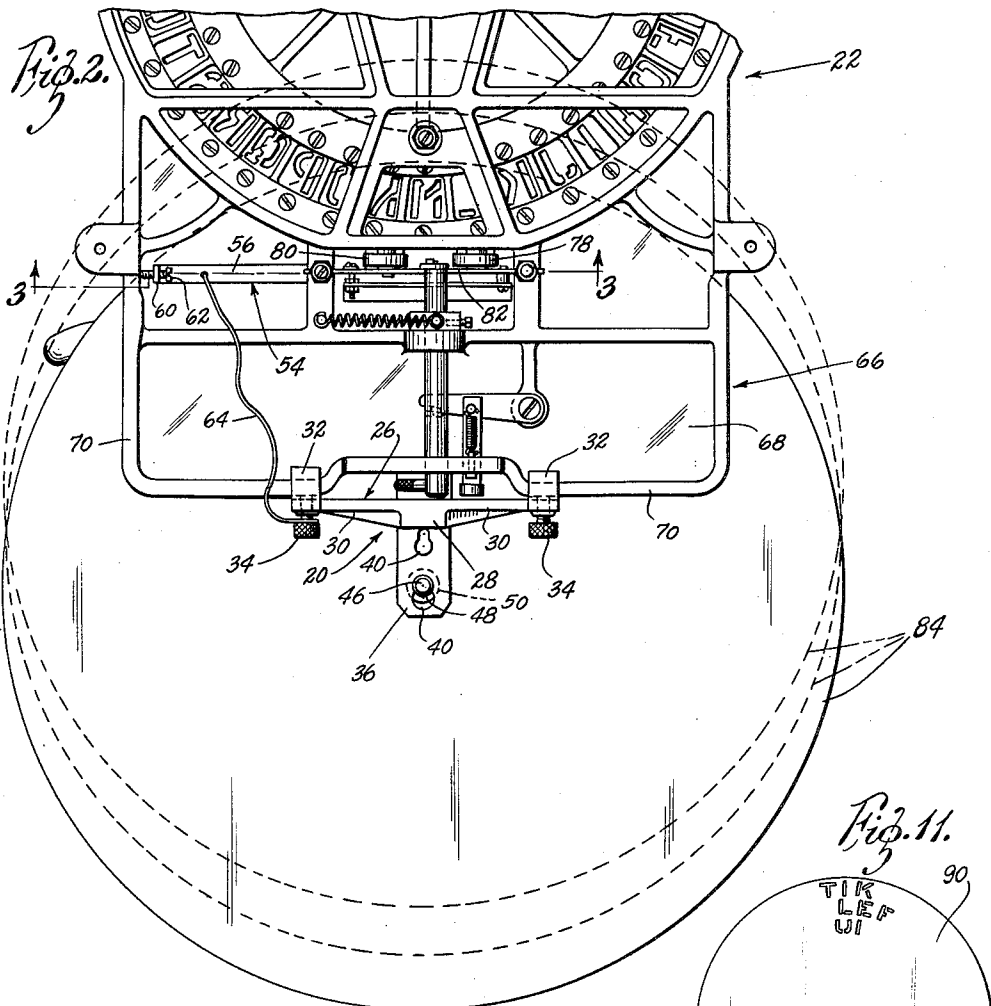

INVENTORS:  
HERBERT W. HEMPEL  
WALTON C. MARSH,  
BY *Kingsland, Rogers & Egel*  
ATTORNEYS

# UNITED STATES PATENT OFFICE

2,506,423

## CIRCULAR STENCIL FEEDING ATTACHMENT

Herbert W. Hempel and Walton C. Marsh, Belleville, Ill., assignors to Marsh Stencil Machine Company, Belleville, Ill., a corporation of Illinois

Application July 13, 1946, Serial No. 683,560

7 Claims. (Cl. 197—6.7)

1

2

The present invention relates generally to the art of stencil cutting, and more particularly to a circular stencil feeding attachment adapted to cooperate with stencil machines built for cutting straight line stencils.

An object of the present invention is to provide a novel circular stencil feeding attachment which is adapted to cooperate with straight line stencil cutting machines.

Another object is to provide a novel attachment for straight line stencil cutting machines by means of which a circular stencil of one or more concentric lines may be cut.

Another object is to provide a novel circular stencil feeding attachment for straight line stencil cutting machines which may be readily attached to or removed from said machine and which firmly maintains a circular stencil blank in pivotal relationship in respect to the machine on which the attachment is mounted.

Another object is to provide a novel circular stencil feeding attachment which incorporates a circular stencil holding and centering device that is readily moved to and maintained in selected pivotal positions in respect to the attachment and a stencil cutting machine on which the attachment is mounted.

Another object is to provide a novel method of cutting a circular stencil.

Other objects are to provide a novel circular stencil feeding attachment which is inexpensive to make, which accurately and efficiently maintains a circular stencil blank in selected position, which is easily applied to a stencil cutting machine and operated in conjunction therewith with a minimum amount of instruction, and which presents a neat attractive appearance.

The foregoing and other objects and advantages are apparent from the following description taken with the accompanying drawings, in which:

Fig. 1 is a top plan view of a stencil cutting machine with the present novel circular stencil feeding attachment mounted thereon in operative position;

Fig. 2 is a bottom plan view of a portion of the stencil cutting machine disclosed in Fig. 1 showing the present attachment operatively secured thereto;

Fig. 3 is a vertical cross-sectional view on the line 3—3 of Fig. 2;

Fig. 4 is a horizontal cross-sectional view on the line 4—4 of Fig. 3 showing the presser roller disabling device mounted to prevent operative

engagement of one of the presser rollers of the stencil cutting machine;

Fig. 5 is a cross-sectional view, similar to Fig. 4, showing the presser roller disabling device about to be inserted in operative position;

Fig. 6 is a cross-sectional view through the stencil blank centering device which forms part of the present novel attachment;

Fig. 7 is a vertical cross-sectional view on the line 7—7 of Fig. 1;

Fig. 8 is a top plan view of the attachment, the stencil blank centering device being omitted for clarity;

Fig. 9 is a side elevational view of the attachment looking in the direction of the arrow A of Fig. 8;

Fig. 10 is a cross-sectional view on the line 10—10 of Fig. 9; and

Fig. 11 is a plan view on a reduced scale of a circular stencil cut on a straight line stencil machine and circularly fed by an embodiment of the present attachment, illustrating three concentric stencil lines.

Referring to the drawings more particularly by reference numerals, and considering Figs. 1 and 2, 20 indicates generally a circular stencil feeding attachment which is mounted on a stencil cutting machine 22. The stencil cutting machine 22 is fully disclosed in our Patent No. 2,293,339, granted August 18, 1942, and is shown in the present case only in sufficient detail for illustrating one adaptation of the present novel attachment.

The attachment 20 includes as the mounting body a bracket 25 (Figs. 8 and 9) which, in a preferred form, is of the configuration shown in the drawings and which may be formed as an aluminum, or other suitable material, casting. The bracket 25 is formed as an arch having a central supporting portion with a transversely sloping surface 28 and legs 30. At the foot of each leg 30 is a clamping jaw 32 through one side of each of which a knurled headed stud 34 threadedly extends (Fig. 2). A generally rectangular plate 36 is secured to the top sloping surface of the supporting portion 28 by suitable screws 38. The plate 36 includes a plurality of spaced keyhole slots 40, four being shown. Where the height of the bracket 25 is just sufficient to dispose the plate 36 slightly above a stencil machine platform, the surface 28 may be horizontal.

The attachment 20 also includes a circular stencil blank centering device 42 (Figs. 1, 6, 7) which comprises a post 44 having a head 46 and

an enlarged flange 48 spaced from the inner surface of the head 46 a distance slightly greater than the thickness of the plate 36 by a neck portion 47. The free end of the post 44 is threaded and receives a threaded knurled cap 50 having a cavity 52.

A presser roller disabling device 54 is provided (Figs. 1 through 5). The device 54 includes an elongated metal strip 56 having a reduced tip 58 at one end and a right angularly bent portion 60 at the other end. The portion 60 has an aperture therethrough which receives an adjustment screw 62. To prevent loss of the device 54, a chain or cable 64 is attached to the device 54 and to some part of the right side of the attachment 20, such as to the right hand knurled stud 34, as shown.

As is now well known, a stencil cutting machine such as the machine 22 shown herein and more particularly disclosed in our above-mentioned patent, includes a base or bed 66 having a front platform portion 68 which has a downwardly directed flange 70, an operating handle 72, a serrated feed roller 74, a follower roller 76, and presser rollers 78 and 80 mounted on a bar or plate 82 guided in slots 83 for movement towards and away from the feed roller 74 and follower roller 76, respectively. For the present purpose of showing the novel attachment 20 mounted on a stencil machine, it is unnecessary to go further into detailed explanations of the stencil machine 22.

In mounting the present attachment 20 on the stencil machine 22, the reduced tip 58 of the presser roller disabling device 54 is inserted between the bar 82 carrying the presser rollers 78 and 80 and the lower surface of the front platform portion 68, as is clearly shown in Fig. 3. The strip 56 is of a length so that the adjusting screw 62 engages the inner surface of the flange 70 and may be securely tightened with a screw driver to maintain the device 54 in place. It may be necessary to turn the stencil machine 22 over on one side the first time the device 54 is inserted. The device 54 is always inserted adjacent the presser roller 80, which is the one disposed below the follower roller 76. The chain 64 is just long enough to permit insertion as set forth above, but not long enough to permit insertion between the presser roller 78 and the feed wheel 74.

The clamping jaws 32 of the device 20 are engaged with the flange 70 in a position to substantially center the device 20 in respect to the character cutting point of the machine 22. As is clearly shown in Fig. 1, the plate 36 will be disposed above the plane of the platform portion 68 and sloping towards the machine 22. The knurled studs 34 are turned to securely clamp the jaws 32 against the flange 70. The post 44 of the stencil centering device 42 is inserted through the center of a stencil blank 84 (Figs. 6 and 7), and the knurled cap 50 is threaded thereon to firmly clamp the stencil blank 84 between the flange 48 and the cap 50. Any excess portion of the center of the blank 84 is accommodated by the cavity 52 of the cap 50. Hence, the cavity 52 obviates the necessity of providing pre-cut central apertures in blanks. The head 46 of the device 42 is inserted through the large portion of a selected keyhole slot 40 until the lower surface of the flange 48 engages the plate 36, whereupon the device 42 is moved to engage the neck portion 47 in the narrow portion of the selected keyhole slot 40. The stencil

blank is then ready for the circular stencil cutting operation.

The cutting of the circular stencil is performed through the normal operation of the handle 72 of the machine 22. However, in view of the fact that the presser roller 80 is blocked from engagement with the stencil blank 84 beneath the follower roller 76 by the device 54, only the feeder roller 74 and its presser roller 78 engage the blank 84 in the feeding action. Where both the presser rollers 78 and 80 operate to firmly press the blank 84 against the feeder wheel 74 and the follower wheel 76, it would be difficult for the stencil 84 to pivot about the post 44. With only the feeder wheel 74 and its presser roller 78 engaging the stencil 84, pivotal movement of the blank 84 readily results. Hence, as the handle 72 is manipulated, a circular stencil 90, such as shown in Fig. 11, is cut.

The present attachment is adapted for cutting concentric stencils of selected diameters measured to the outside circumference of the characters. A preferred attachment is formed to cut circles with outside diameters of 20 inches, 17 inches, 14 inches, and 11 inches. The particular diameter is, of course, determined by the particular keyhole slot 40 selected for mounting the centering device 42.

The attachment 20 is illustrated in connection with the particular stencil cutting machine 22, but the present attachment 20 is readily adapted to use with stencil cutting machines generally.

It is apparent from the foregoing description, taken with the accompanying drawings, that there has been provided a circular stencil feed attachment which fulfills all of the objects and advantages sought therefor.

The foregoing description and the accompanying drawings have been given by way of illustration and example. It is to be understood that changes in form, substitution of equivalent elements, and rearrangement of parts that will be manifest to those skilled in the art are contemplated as within the scope of the present invention, which is limited only by the claims which follow.

What is claimed is:

1. A stencil machine attachment for feeding circular stencil blanks comprising a bracket, means for attaching said bracket to a stencil machine, and means supported by said bracket for receiving a circular stencil blank in any one of a plurality of positions in respect to a stencil machine to cut stencils of varying diameter therein, said receiving means including a cap member formed to accommodate surplus material punched from the center of a received stencil blank.
2. A stencil machine attachment for feeding circular stencil blanks comprising a bracket, means for attaching said bracket to a stencil machine, a plate supported by said bracket to receive a circular stencil blank, and means for rendering inoperative one of the feed wheels of the stencil machine to which the attachment is connected to facilitate circular feeding of a received circular stencil blank, said last named means including a feed wheel disabling member, said feed wheel disabling member being connected to an end of said bracket by a flexible member of predetermined length permitting disabling only of one predetermined feed wheel of the stencil machine.

5

3. A stencil machine attachment for feeding circular stencil blanks comprising a bracket, means for attaching said bracket to a stencil machine, a plate supported by said bracket, a pivot post supported by said plate adapted to receive a circular stencil blank, and means for rendering inoperative one of the feed wheels of the stencil machine to which the attachment is connected to facilitate circular feeding of a received circular stencil blank, said last-named means including a feed wheel disabling member, said feed wheel disabling member being connected to an end of said bracket by a flexible member of predetermined length permitting disabling only of one predetermined feed wheel of the stencil machine.

4. An attachment for stencil machines for feeding circular stencil blanks comprising a support, means for attaching said support to a stencil machine, a plate supported by said support having a plurality of aligned keyhole slots, and a circular stencil blank centering device removably connected to a selected slot.

5. An attachment for stencil machines for feeding circular stencil blanks comprising a support, means for attaching said support to a stencil machine, a plate supported by said support having a plurality of aligned keyhole slots, a circular stencil blank centering device removably connected to a selected slot, and means for rendering a portion of the feeding mechanism of the stencil machine inoperative to facilitate pivotal movement of a circular stencil blank held centered by the attachment.

6. A stencil machine attachment for feeding circular stencil blanks comprising a bracket member having means for removably connecting the same to a stencil machine, an elongated plate

6

member secured to said bracket member transversely thereto, a plurality of aligned keyhole slots in said plate member, a stencil blank receiving member removably disposed in a selected slot, and a stencil machine feed wheel disabling member, connected to said bracket member.

7. A stencil machine attachment for feeding circular stencil blanks comprising a bracket member having means for removably connecting the same to a stencil machine, an elongated plate member secured to said bracket member transversely thereto, a plurality of aligned keyhole slots in said plate member, a stencil blank receiving member removably disposed in a selected slot, and a stencil machine feed wheel disabling member, said feed wheel disabling member being connected to an end of said bracket member by a flexible member of predetermined length permitting disabling only of one predetermined feed wheel of the stencil machine.

HERBERT W. HEMPEL.  
WALTON C. MARSH.

#### REFERENCES CITED

The following references are of record in the file of this patent:

#### UNITED STATES PATENTS

Number	Name	Date
544,193	Pickles et al. ....	Aug. 6, 1895
561,990	Hartog, Jr. ....	June 16, 1896
573,841	Hoff et al. ....	Dec. 22, 1896
612,892	Bradley ....	Oct. 25, 1898
644,087	Moore ....	Feb. 27, 1900
675,786	Munson ....	June 4, 1901
848,824	Hawkins ....	Apr. 2, 1907
997,583	Remsnider ....	July 11, 1911
1,149,151	Birkenmaier ....	Aug. 3, 1915