

Feb. 7, 1967

SHOZO SHIOKAWA

3,302,505

MACHINE PRESS

Filed Jan. 11, 1965

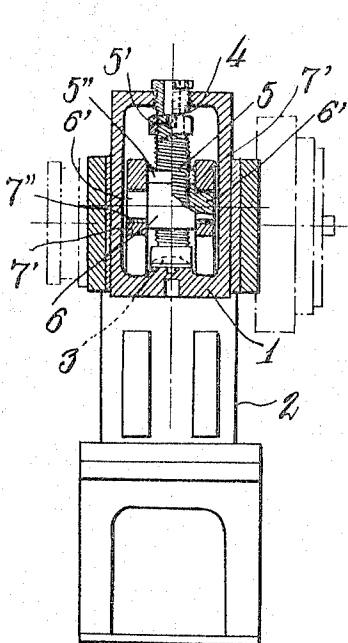

Fig. 2,

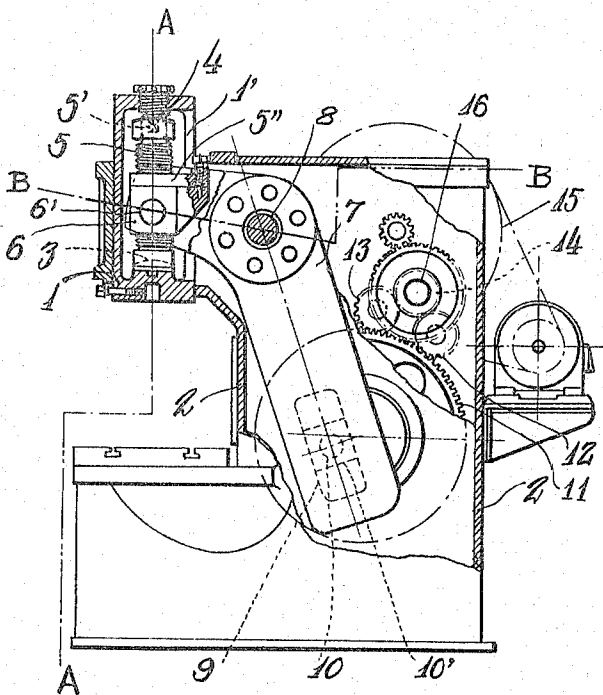

Fig. 1,

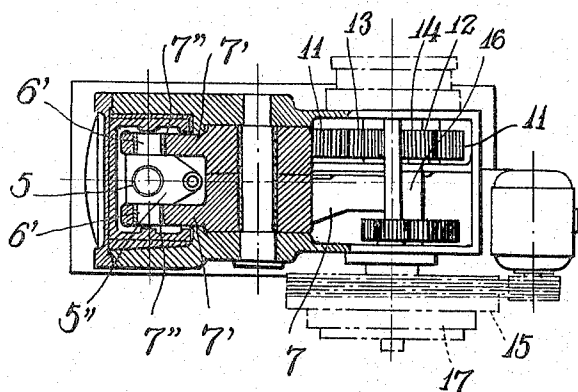

Fig. 3,

*Shozo Shiokawa*

INVENTOR.

BY *Weenderoth*  
*Lind and Ponack*  
*attorneys*

1

3,302,505

**MACHINE PRESS**

Shozo Shiokawa, Toyonaka, Osaka-fu, Japan, assignor to  
Hiroyasu Shiokawa, Toyonaka, Japan

Filed Jan. 11, 1965, Ser. No. 424,786

Claims priority, application Japan, Jan. 17, 1964,

39/2,815

2 Claims. (Cl. 83—628)

The present invention relates to an improved machine press.

A particular object of the invention is to provide a machine press characterized by being small in size but producing a high pressure.

A further object of the invention is to provide a press which has the advantage that the pressing power thereof increases in comparison with the revolving power of the crank, whereby it is possible to obtain a large pressing power with a small motive power and a compact but highly efficient press. Further, by making the pinion gears engage with the pinion gear of a flywheel shaft and with the gear wheel of the press at the same time, the force conveyed by the rotation is doubled, so that the diameter of the gear wheel can be reduced by half. As the result, it becomes possible to reduce the measurements of the machine by placing all the gears in the frame and also to reduce the wear and noise of each part by means which always stores a certain amount of lubricant oil in the box-shaped frame. Further the ram is adjustable in a vertical direction and yet the upper and lower supporting members each having a curved surface provided in the ram support both ends of the ram adjusting threaded shaft.

Accordingly, the ram receives the back pressure which arises at the moment of metal cutting or punching, and thus it has an advantage of preventing damage which might be caused by the back pressure.

The invention will now be described in connection with the accompanying drawings in which;

FIG. 1 is a vertical-sectional side view; FIG. 2 is a vertical-sectional front view along line A—A of FIG. 1; and FIG. 3 is a horizontal-sectional view along line B—B in FIG. 1.

A box-shaped ram 1 is set in a guide hole provided at the front upper part of the box-shaped frame 2 of a C-type frame machine press. The ram 1 has an opening 1' in the back thereof and a supporting member 3 having an upwardly convex curved surface on its bottom. It also has another supporting member 4 with downwardly convex curved lower surface, which is threadedly mounted on the ram 1. A ram adjusting threaded shaft 5 is positioned between the two supporting members 3 and 4. A nut 6 threaded onto the ram adjusting shaft 5 has shafts 6' and 6' projecting from the opposite sides thereof, which shafts are respectively positioned in holes 7', 7' provided on the two heads 7', 7' of a lever 7.

The ram adjusting shaft 5 has a square recess 5' in the top end thereof so that, by removing the upper supporting member 4 and inserting a square rod into the square recess 5' and turning it, the point of engagement of the ram adjusting shaft 5 and the nut 6 can be changed and accordingly the ram 1 can be adjusted in the vertical direction. The ram adjusting shaft 5 has also a detent 5'', by means of which backward turning of the nut 6 is checked. The upper part of the lever 7 which has the two heads 7' bends nearly at a right angle, and at the point at which it bends it is supported on a supporting shaft 8 provided on the upper part of the frame 2. In the end of the lever 7 at the lower part of the frame 2, a slot 9 is provided, in which a slidable member 10' is slidably positioned.

2

The slidable member 10' is mounted on a crankshaft 10, which in turn is fixed to a gear wheel 11. A pinion gear 14 is mounted on the shaft 16 of a flywheel 15 and engages with other pinion gears 12, 13 which are provided side by side and in mesh with the said pinion gear 14 and the gear wheel 11. Between the flywheel 15 and its shaft 16, is positioned a compressed air type friction clutch 17. When the shaft 16 of the flywheel 15 turns, the rotation is conveyed to the crankshaft 10 through to pinion gears 12, 13, 14 and the gear wheel 11. Then, the lever 7 starts its motion and moves both the ram adjusting shaft 5 and the ram 1 up and down by moving the nut 6 connected with the two heads 7', 7' of the lever 7.

The machine press in accordance with the present invention having the structure as described above causes the pressure to be exerted on the ram 1 by the lever 7 to increase remarkably.

Further, by making the pinion gears 12, 13 engage with the pinion gear 14 of the flywheel shaft 16 and with the gear wheel 11 at the same time, the force conveyed by the rotation is doubled, so that the diameter of the gear wheel 11 can be reduced by half. As a result, it becomes possible to reduce the measurements of the machine by placing all the gears within the frame and also to reduce the wear and noise of each part by always keeping a certain amount of lubricant oil in the frame. The ram 1 is adjustable in a vertical direction and yet the upper and lower supporting members 3 and 4 having the curved surfaces support both ends of the ram adjusting shaft 5.

Accordingly, the ram 1 receives the back pressure which arises at the moment of metal cutting or punching, and prevents damage to be caused by the back pressure.

What I claim as my invention:

1. A machine press comprising a C-type frame, a supporting shaft in said frame, a lever rotatably supported on said supporting shaft and having one end in the lower part of said frame and having a slot in said one end, a crankshaft slidably mounted in said slot, a gear wheel rotatably mounted in said frame and on which said crankshaft is eccentrically mounted, a flywheel shaft rotatably mounted in said frame, a flywheel on said flywheel shaft, a pinion gear on said flywheel shaft, two intermediate pinions meshed with said pinion gear and said gear wheel, the other end of said lever having two heads thereon, a nut rotatably mounted between the two heads on said other end of said lever, a ram adjusting threaded shaft threadedly mounted in said nut, a hollow ram slidably mounted in the end of the C-type frame for vertical movement therein, and supporting members on both ends of said ram between which said threaded adjusting shaft is mounted, said ram having an opening in the back thereof through which said two heads on said lever enter the ram.

2. A machine press as claimed in claim 1 in which the lower of said supporting members has an upwardly convexly curved surface and the upper of said supporting members has a downwardly convexly curved surface, said curved surfaces being slidably engaged with complementary surfaces on said threaded adjusting shaft.

**References Cited by the Examiner**

**FOREIGN PATENTS**

244,439 1/1961 Australia.

WILLIAM S. LAWSON, *Primary Examiner.*

L. B. TAYLOR, *Assistant Examiner.*