

(19) World Intellectual Property Organization
International Bureau



(43) International Publication Date
7 June 2007 (07.06.2007)

PCT

(10) International Publication Number
WO 2007/062987 A1

(51) International Patent Classification:
D06F 37/06 (2006.01)

(21) International Application Number:
PCT/EP2006/068555

(22) International Filing Date:
16 November 2006 (16.11.2006)

(25) Filing Language: English

(26) Publication Language: English

(30) Priority Data:
P 200503075 2 December 2005 (02.12.2005) ES

(71) Applicant (for all designated States except US): **BSH BOSCH UND SIEMENS HAUSGERÄTE GMBH** [DE/DE]; Carl-Wery-Str. 34, 81739 München (DE).

(72) Inventor; and

(75) Inventor/Applicant (for US only): **GRACIA BOBED, Ismael** [ES/ES]; C/ La Alberca, 3, Casa 1, E-50194 Zaragoza (ES).

(74) Common Representative: **BSH BOSCH UND SIEMENS HAUSGERÄTE GMBH**; Carl-Wery-Str. 34, 81739 München (DE).

(81) Designated States (unless otherwise indicated, for every kind of national protection available): AE, AG, AL, AM, AT, AU, AZ, BA, BB, BG, BR, BW, BY, BZ, CA, CH, CN, CO, CR, CU, CZ, DE, DK, DM, DZ, EC, EE, EG, ES, FI, GB, GD, GE, GH, GM, GT, HN, HR, HU, ID, IL, IN, IS, JP, KE, KG, KM, KN, KP, KR, KZ, LA, LC, LK, LR, LS, LT, LU, LV, LY, MA, MD, MG, MK, MN, MW, MX, MY, MZ, NA, NG, NI, NO, NZ, OM, PG, PH, PL, PT, RO, RS, RU, SC, SD, SE, SG, SK, SL, SM, SV, SY, TJ, TM, TN, TR, TT, TZ, UA, UG, US, UZ, VC, VN, ZA, ZM, ZW.

(84) Designated States (unless otherwise indicated, for every kind of regional protection available): ARIPO (BW, GH, GM, KE, LS, MW, MZ, NA, SD, SL, SZ, TZ, UG, ZM, ZW), Eurasian (AM, AZ, BY, KG, KZ, MD, RU, TJ, TM), European (AT, BE, BG, CH, CY, CZ, DE, DK, EE, ES, FI, FR, GB, GR, HU, IE, IS, IT, LT, LU, LV, MC, NL, PL, PT, RO, SE, SI, SK, TR), OAPI (BF, BJ, CF, CG, CI, CM, GA, GN, GQ, GW, ML, MR, NE, SN, TD, TG).

Published:
— with international search report

For two-letter codes and other abbreviations, refer to the "Guidance Notes on Codes and Abbreviations" appearing at the beginning of each regular issue of the PCT Gazette.

(54) Title: A LAUNDRY DRUM

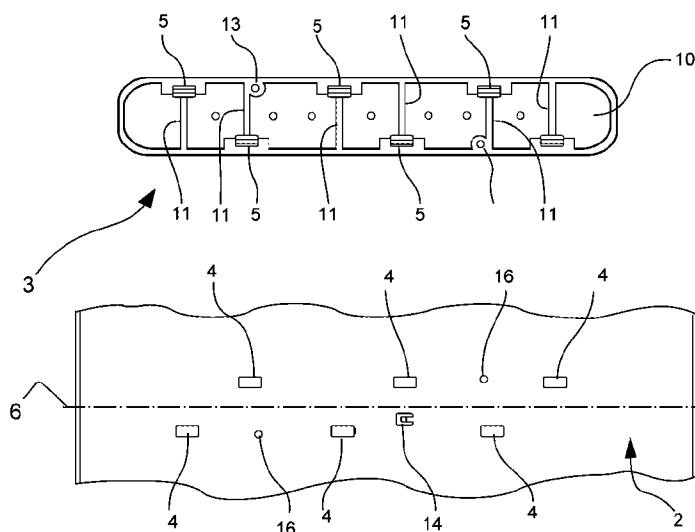

(57) Abstract: A laundry drum comprises a drum having a cylindrical band (2), at least two rows of receptacles (4) defined on the cylindrical band (2), said receptacles (4) arranged in a staggered sequence along a central line (6) therebetween; and at least one paddle (3) fastened to the cylindrical band (2) on an inside of said drum by means of two corresponding rows of elastic clips (5) extended from the paddle (5) and being held in said receptacles (4). Such arrangement of the receptacles (4) provide a possible larger area a long the peripheral direction of the receptacles to distribute the stresses formed when the drum spins at a high speed in operation of washing, rinsing or the like.

WO 2007/062987 A1

A laundry drum

Description

[0001] The present invention relates to a laundry drum for a drum-type washing machine, dryer or the like.

[0002] The use of rotating drum-type washing machine is generally known. It is conventional in such machines to utilize a number, for example three or four agitating paddles projected inwardly in the inside of the drum to promote the tumbling of articles being laundered during the washing and rinsing operation. Great Britain Pat. No. 1,161,219 A issued to Philips Electronic on Aug. 13, 1969 exemplifies a plastic rib of substantially triangular cross-section with closed ends so as to be in the form of a trough fastened to the inside of the drum by means of projections extended from the edge of the trough and being held in two rows of co-operating keyhole slots in the wall of the drum. The keyhole slots are in a mirrored arrangement with respect to a central line between the two rows of the slots. The problem with this arrangement of slots is that it will weaken excessively the wall of the drum, because operational stress within the wall of the drum cannot be distributed into regions between mirrored pairs of slots, thus causing inequalities in stress distribution. On that way stresses are unevenly distributed and failure by breakage may occur when working at a high spinning speed (e.g. 1500 rpm) during washing, rinsing or the like operation.

[0003] Moreover, the rib being secured to the cylindrical wall of the drum by the projections provided on the edges of the trough engaging with the

co-operating keyhole slots in the wall, obviously another fastening element such as a screw as described in the prior art must be necessary for retaining the rib in position after being engaged with the wall on the ground that the projections will gradually deform plastically subjected to forces exerted from the engagement between the projections and slots and as a result may slide out of the slots over a long period of time.

[0004] Accordingly, one of the objectives of the present invention is to provide an improved laundry drum for a drum-type machine that provides a possible larger area along the peripheral direction of the drum to distribute the stresses originated when the drum spins at a high speed so as to avoid the deformation of the drum.

[0005] Yet another aim of the present invention is to provide an improved laundry drum, in which the receptacles can secure and retain the clips of the paddle in position respectively, even without the help of the fastening elements such as securing screws, rivets, etc.

[0006] According to the present invention, the above-mentioned aims are achieved by an improved laundry drum comprising a drum having a cylindrical band, at least two rows of receptacles defined on the cylindrical band, said receptacles arranged in a staggered sequence along a central line therebetween; and at least one paddle fastened to the cylindrical band on an inside of said drum by means of two corresponding rows of elastic clips extended from the paddle and being held in said receptacles. Such arrangement of the receptacles

provides a larger area along the peripheral direction of the drum to distribute the stresses formed when the drum spins at a high speed in operation of washing, rinsing or the like.

[0007] According to a further feature of the present invention, each receptacle defined in the cylindrical band comprises a protrusion forming an inclination portion and a holding portion. When the paddle is assembled onto the drum, the clips of the paddle slide along the inclination portion and are securely held in the holding portion of the receptacles, respectively. Each of the protrusions preferably includes a cross-section of a triangle for forming the inclination portion and a rectangle for forming the holding portion together with the other side wall of the receptacle so as to secure the paddle permanent in the holding portion and prevent the paddle from moving back or disassembling.

[0008] According to a further feature of the present invention, the corresponding two rows of clips extended from the paddle have rotational symmetry, which provides an easy way to assemble the paddle to the drum in both senses in spite of the asymmetry of the receptacles.

[0009] Other objects, advantages and novel features of the invention will become apparent from the following detailed description of a preferred embodiment when taken in conjunction with the accompanying drawings.

Fig. 1 is a general perspective view of a paddle and the portion of the laundry drum to which it is to be secured;

Fig. 2 illustrates a detailed perspective view of a clip from the paddle as shown in Fig. 1;

Fig. 3 illustrates an assembly process of a clip of the paddle before clipping and clipped;

FIG. 4 is a perspective view of the paddle assembly.

[0010] Referring to Fig. 1, a laundry drum 1 for a drum-type washing machine, dryer or the like comprises a cylindrical band 2 and at least one paddle 3 fastened on an inside of the drum 1. At least two rows of receptacles 4 are defined on said band 2 for correspondingly receiving two rows of clips 5 extended from the paddle 3. Said receptacles 4 are arranged in a staggered sequence along a central line 6 between the two rows breaking with the symmetry of the receptacles 4, as a consequence, providing a relative larger area around to distribute the forces when the drum is spinning at a high speed during washing, rinsing or the like operation. In the present embodiment, the central line 6 is parallel to the rotating axis of the drum 1, equal numbers of receptacles are defined on both sides of the central line 6. Alternatively, the central line 6 may not be parallel to the rotating axis of the drum, different number of receptacles may be defined on both sides of the central line 6, provided that the receptacles 3 defined on the band 2 can meet the requirements of mechanical property to hold the paddle 3 securely on the band 2.

[0011] By referring to Fig. 3, each of the receptacles 4 further comprise a

protrusion 7 projecting inwardly in each of the receptacles 4, separating each of the receptacles 4 into an inclination portion 8 and a holding portion 9. Said protrusion 7 includes a cross-section of a triangle forming the inclination portion 8 and a rectangle forming the holding portion 9 together with the other side walls of each of the receptacles 4. When the paddle 3 is assembled onto the drum 1, the clips 5 of the paddle 3 slide along the inclination portion 8 and eventually are held at the holding portion 9. Preferably the inclination portion 8 has an angle at substantially 45 degrees. A junction of the holding portion 9 and the inclination portion 8 has an angle at 90 degrees, which provides that this engagement between the clips 5 and the holding portion 9 of the corresponding receptacle 4 is of a permanent type and with no substantial freedom of movement.

[0012] As shown in Fig. 1, the two rows of clips 5 extended from the paddle 3 preferably have rotational symmetry, which provides that the worker has a great facility of assembly since the paddle 3 can be assembled in both senses in spite of the asymmetry of the receptacles 4 of the cylindrical band 2.

[0013] The paddle 3 as shown in Figs. 1 and 2 further comprises a hollow body 10 being open toward the cylindrical band 2 at the region where the paddle 3 is secured, a plurality of parallel interior nerves 11 locate in the hollow body 10 to increase the rigidity of the paddle 3, one end of each of the interior nerves 11 having a protrusion base 12 extended from an inside of the paddle 3. When the paddle 3 is assembled together with the drum 1, the receptacles 4 will be covered by the protrusion base 12 respectively. Preferably, at least a threaded hole 13 is

disposed at one end being opposite to the protrusion base 12 of the interior nerves 11 to lodge a fastening element such as a screw through a corresponding hole 16 in the cylindrical band 2 for a better fixing of the paddle 3 to the cylindrical band 2. Also, at least one tab 14 extends inwardly along one row of the two rows of receptacles 4 to engage with one of the interior nerves 11 for preventing the paddle 2 from moving back after being assembled.

[0014] Furthermore, to form a better so-called "rain effect", which means that after being lead upward by the paddle 3, the water falls down better in a manner like a shower to moisten the articles in laundry, a plurality of leaks 15 are disposed on an upper side 17 of the paddle 3 as shown in Fig. 4.

[0015] Also as shown in Fig. 4, the overall length L' of the paddle 3 is made shorter than the distance L between two circular end walls of the drum 1 so that trapping of the articles being laundered is obviated.

[0016] It is to be understood that even though numerous characteristics and advantages of the present invention have been set forth in the foregoing description, together with details of the structure and function of the invention, the disclosure is illustrative only, and changes may be made in detail, especially in matters of shape, size, and arrangement of parts within the principles of the invention to the full extent indicated by the broad general meaning of the terms in which the appended claims are expressed.

Claims

1. A laundry drum, comprising:
a cylindrical band (2), at least two rows of receptacles (4) defined on the cylindrical band (2), said receptacles (4) arranged in a staggered sequence along a central line (6) therebetween; and
at least one paddle (3) fastened to the cylindrical band (2) on an inside of said drum by means of two corresponding rows of elastic clips (5) extended from the paddle (3) and being held in said receptacles (4).
2. The laundry drum according to claim 1, wherein:
said central line (6) is substantially parallel to the rotational axis of the drum.
3. The laundry drum according to claim 1, wherein:
a protrusion (7) extended inwardly in each of said receptacles (4) forms an inclination portion (8) for sliding said clips (5) and a holding portion (9) for securing said clips (5).
4. The laundry drum according to claim 3, wherein:
the protrusion (7) includes a cross-section of a substantially triangle and a rectangle.
5. The laundry drum according to claim 1, wherein:
said two rows of clips (5) have rotational symmetry.
6. The laundry drum according to claim 1, wherein:
said paddle (3) further comprises a hollow body (10) being open toward

the band (2) in a region where the paddle (3) is fastened, a plurality of interior nerves (11) located inside of the body (10), one end of each of said nerves (11) ending with a protrusion base (12) extended from an inside of the paddle (3).

7. The laundry drum according to claim 6, wherein:

at least one threaded hole (13) is defined at one end of one of said nerves (11) to lodge a screw through a corresponding hole (16) defined on said cylindrical band (2).

8. The laundry drum according to claim 6, wherein:

a tab (14) extends inwardly from said cylindrical band (2) for engaging with one of the nerves (11).

9. The laundry drum according to claim 1, wherein:

a plurality of leaks (15) are defined on an upper side (17) of said paddle (3) for having a rain effect in process.

10. The laundry drum according to claim 1, wherein:

an overall length of the paddle (3) is less than a distance between two circular end walls of the drum.

11. The laundry drum according to claim 1, wherein:

said paddle (3) is made of plastic.

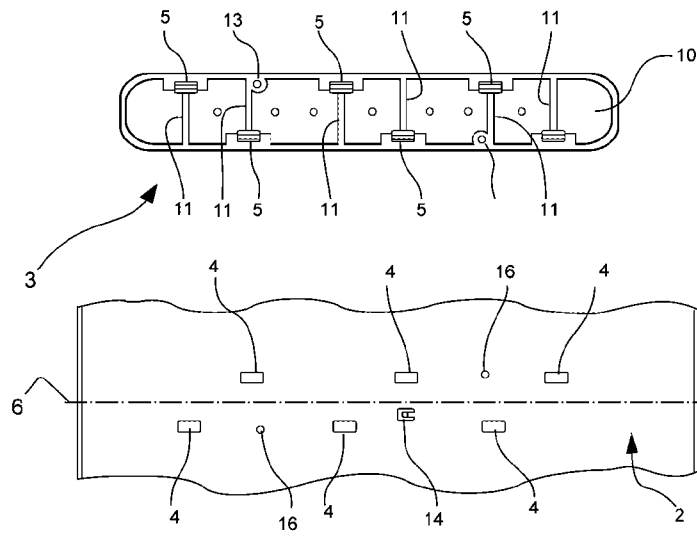

Fig. 1

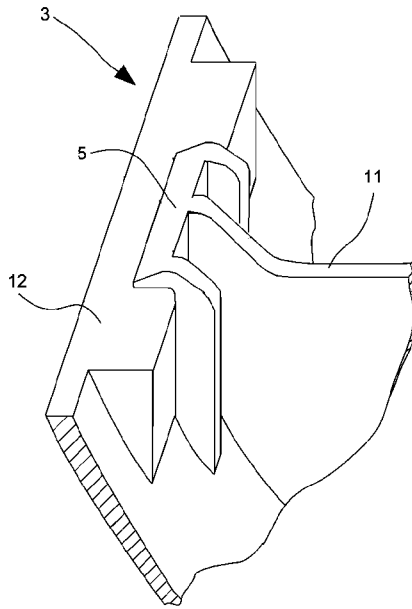

Fig.2

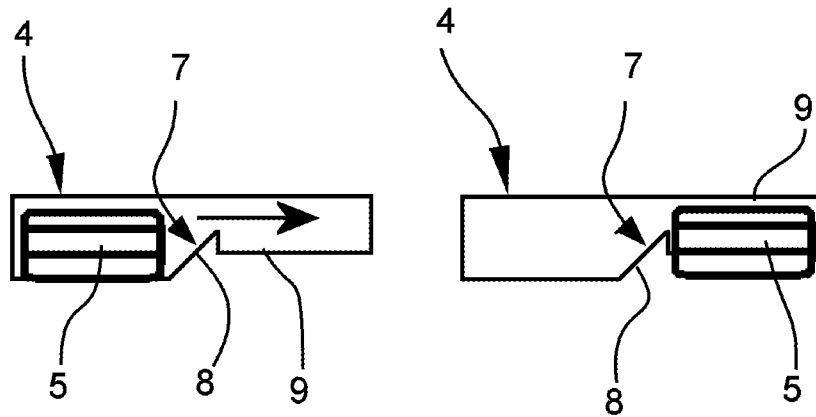

Fig.3

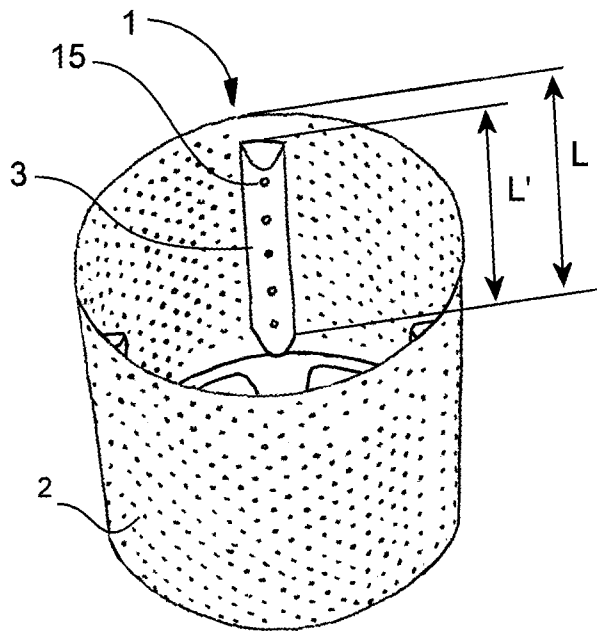

Fig.4

INTERNATIONAL SEARCH REPORT

International application No
PCT/EP2006/068555

A. CLASSIFICATION OF SUBJECT MATTER
INV. D06F37/06

According to International Patent Classification (IPC) or to both national classification and IPC

B. FIELDS SEARCHED

Minimum documentation searched (classification system followed by classification symbols)
D06F

Documentation searched other than minimum documentation to the extent that such documents are included in the fields searched

Electronic data base consulted during the international search (name of data base and, where practical, search terms used)

EPO-Internal

C. DOCUMENTS CONSIDERED TO BE RELEVANT

Category*	Citation of document, with indication, where appropriate, of the relevant passages	Relevant to claim No.
A	GB 1 161 219 A (PHILIPS ELECTRONIC ASSOCIATED [GB]) 13 August 1969 (1969-08-13) cited in the application the whole document -----	1

Further documents are listed in the continuation of Box C.

See patent family annex.

* Special categories of cited documents :

- *A* document defining the general state of the art which is not considered to be of particular relevance
- *E* earlier document but published on or after the international filing date
- *L* document which may throw doubts on priority claim(s) or which is cited to establish the publication date of another citation or other special reason (as specified)
- *O* document referring to an oral disclosure, use, exhibition or other means
- *P* document published prior to the international filing date but later than the priority date claimed

- *T* later document published after the international filing date or priority date and not in conflict with the application but cited to understand the principle or theory underlying the invention
- *X* document of particular relevance; the claimed invention cannot be considered novel or cannot be considered to involve an inventive step when the document is taken alone
- *Y* document of particular relevance; the claimed invention cannot be considered to involve an inventive step when the document is combined with one or more other such documents, such combination being obvious to a person skilled in the art.
- *Z* document member of the same patent family

Date of the actual completion of the international search

13 February 2007

Date of mailing of the international search report

20/02/2007

Name and mailing address of the ISA/

European Patent Office, P.B. 5818 Patentlaan 2
 NL - 2280 HV Rijswijk
 Tel. (+31-70) 340-2040, Tx. 31 651 epo nl,
 Fax: (+31-70) 340-3016

Authorized officer

FAYMANN, L

INTERNATIONAL SEARCH REPORT

Information on patent family members

International application No
PCT/EP2006/068555

Patent document cited in search report		Publication date		Patent family member(s)	Publication date
GB 1161219	A	13-08-1969	DE	1585867 A1	07-10-1971
			ES	344570 A1	16-12-1968
