



US00D719495S

(12) **United States Design Patent**
Burak

(10) **Patent No.:** **US D719,495 S**

(45) **Date of Patent:** **** Dec. 16, 2014**

(54) **VEHICLE FURNITURE**

(71) Applicant: **Tourism Holdings Limited**, Hamilton (NZ)

(72) Inventor: **Edward John Burak**, Hamilton (NZ)

(73) Assignee: **Tourism Holdings Limited**, Hamilton (NZ)

(**) Term: **14 Years**

(21) Appl. No.: **29/438,759**

(22) Filed: **Dec. 3, 2012**

(30) **Foreign Application Priority Data**

Jun. 8, 2012 (NZ) 416345

(51) **LOC (10) CI.** **12-16**

(52) **U.S. CI.**
USPC **D12/195**

(58) **Field of Classification Search**

USPC D12/195, 193, 414, 190, 196; 180/190;
280/750-752; 296/190.01-191, 70,
296/193.08, 145, 153, 37.1-37.13, 149,
296/146.1; D15/17, 28; D10/46, 98,
D10/102-103; 49/501-502; D8/302-303
See application file for complete search history.

(56) **References Cited**

U.S. PATENT DOCUMENTS

2,842,185 A * 7/1958 Fortine 297/124
5,088,135 A * 2/1992 Violette 5/2.1
5,704,683 A * 1/1998 Cooper et al. 297/124
6,113,182 A * 9/2000 Wise 297/119
7,399,031 B2 * 7/2008 Gardner 297/118
7,896,432 B2 * 3/2011 Dunkel 297/124

8,342,450 B2 * 1/2013 Funke et al. 244/118.6
2010/0171344 A1 * 7/2010 Dunkel 297/130
2010/0201163 A1 * 8/2010 Dunkel 297/124

* cited by examiner

Primary Examiner — Katrina A Betton

(74) *Attorney, Agent, or Firm* — Workman Nydegger

(57) **CLAIM**

The ornamental design for vehicle furniture, as shown and described.

DESCRIPTION

FIG. 1 is a perspective view of vehicle furniture showing my new design with a table down and a bed down;

FIG. 2 is a top plan view thereof;

FIG. 3 is a front elevational view thereof;

FIG. 4 is a rear elevational view thereof;

FIG. 5 is a right side elevational view thereof;

FIG. 6 is a left side elevational view thereof;

FIG. 7 is a perspective view of the vehicle furniture showing the table up and the bed up;

FIG. 8 is a top plan view thereof;

FIG. 9 is a front elevational view thereof;

FIG. 10 is a rear elevational view thereof;

FIG. 11 is a right side elevational view thereof;

FIG. 12 is a left side elevational view thereof;

FIG. 13 is a perspective view of vehicle furniture showing the table down and the bed up;

FIG. 14 is a top plan view thereof;

FIG. 15 is a front elevational view thereof;

FIG. 16 is a rear elevational view thereof;

FIG. 17 is a right side elevational view thereof; and,

FIG. 18 is a left side elevational view thereof.

The broken lines showing the environment are for the purpose of illustration and form no part of the claimed design.

1 Claim, 18 Drawing Sheets

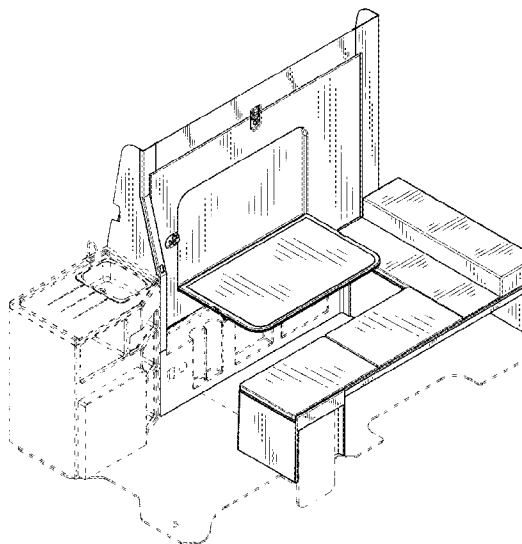
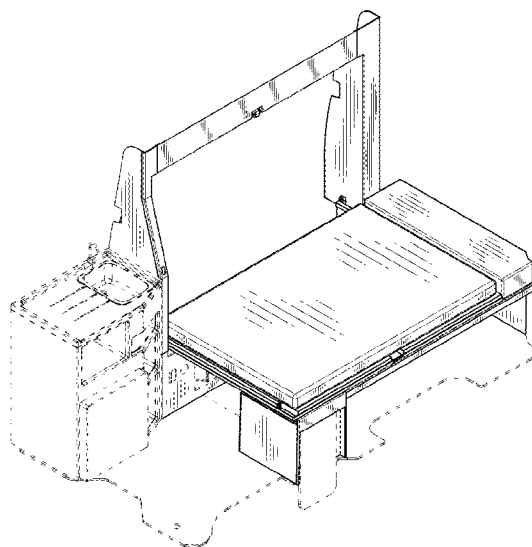

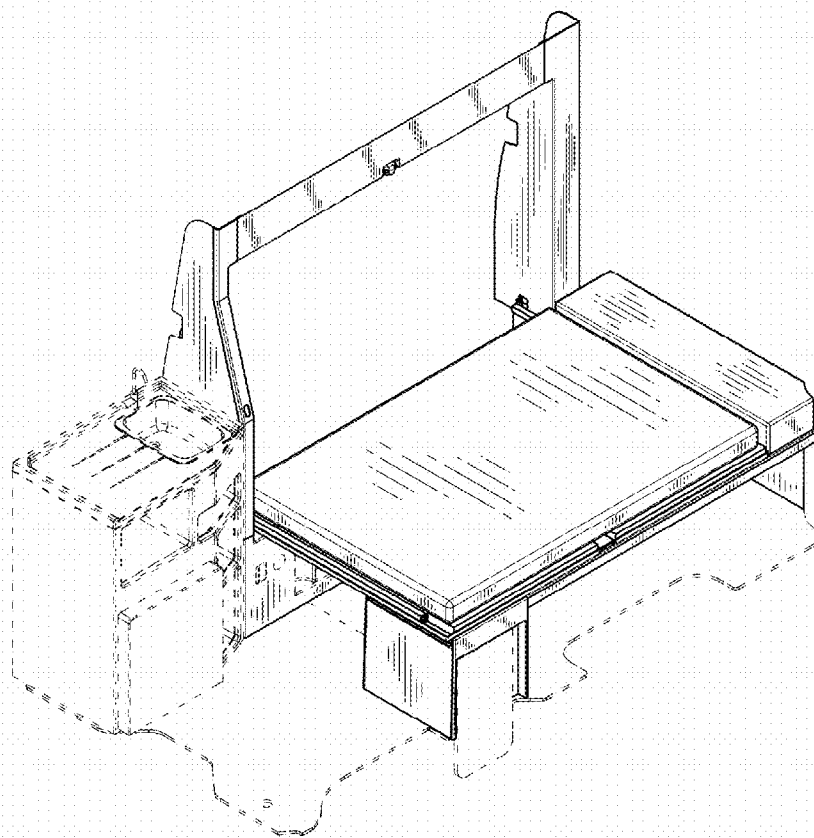

FIGURE 1

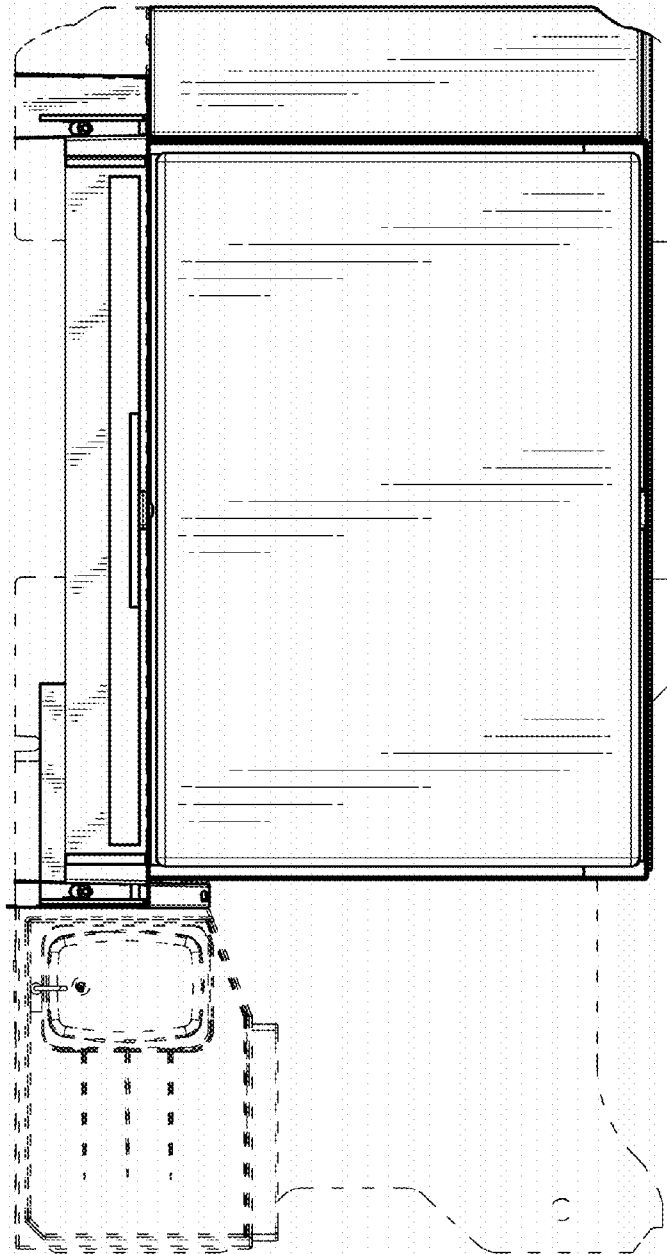

FIGURE 2

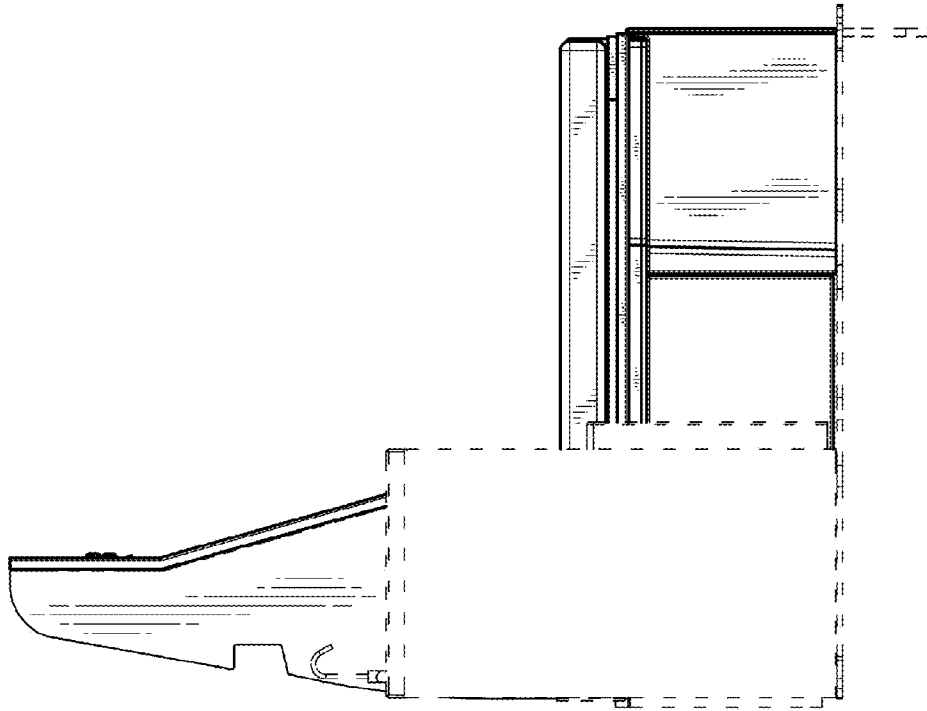

FIGURE 3

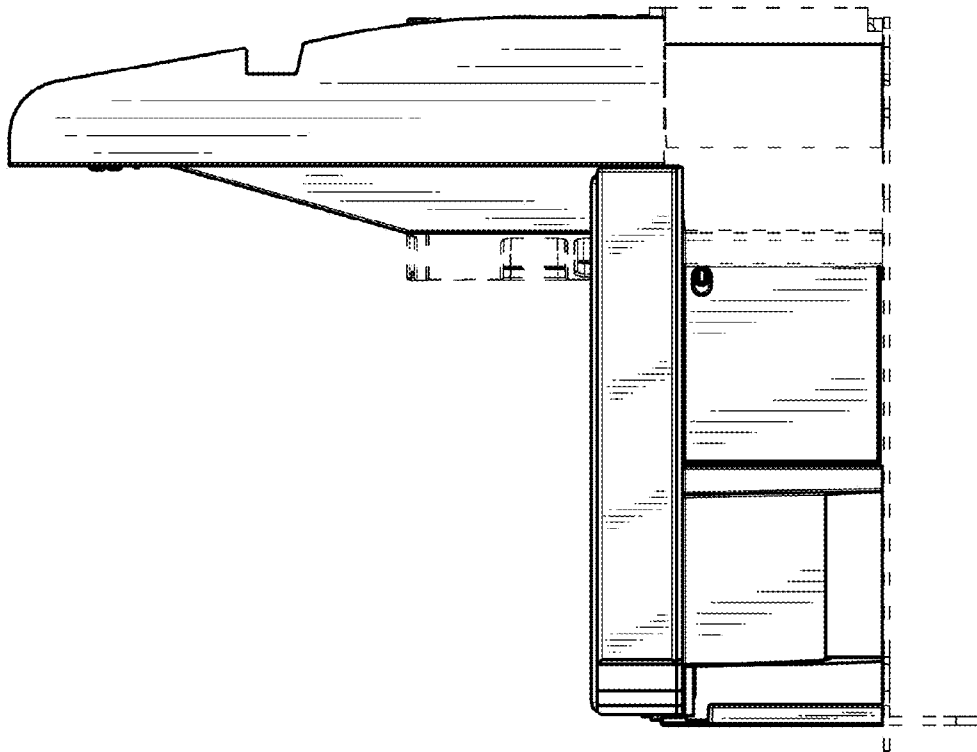

FIGURE 4

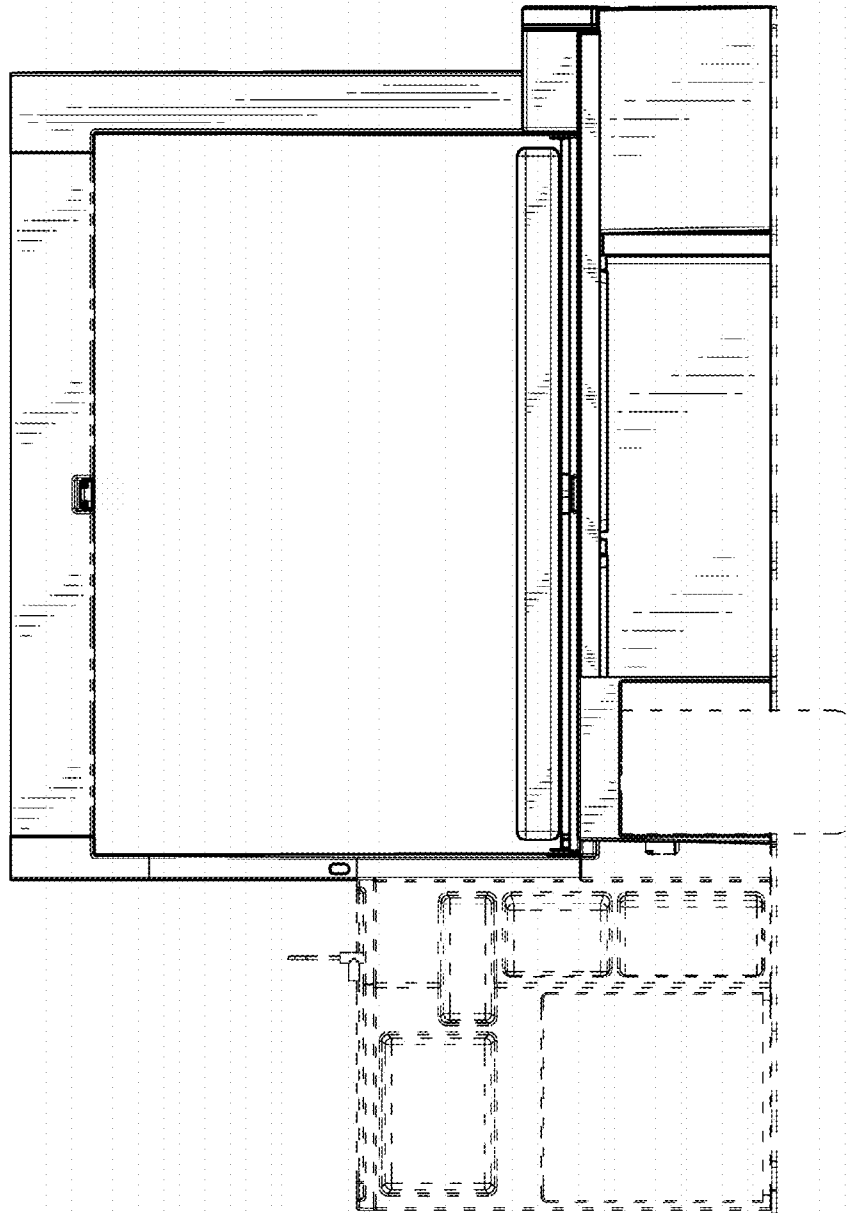

FIGURE 5

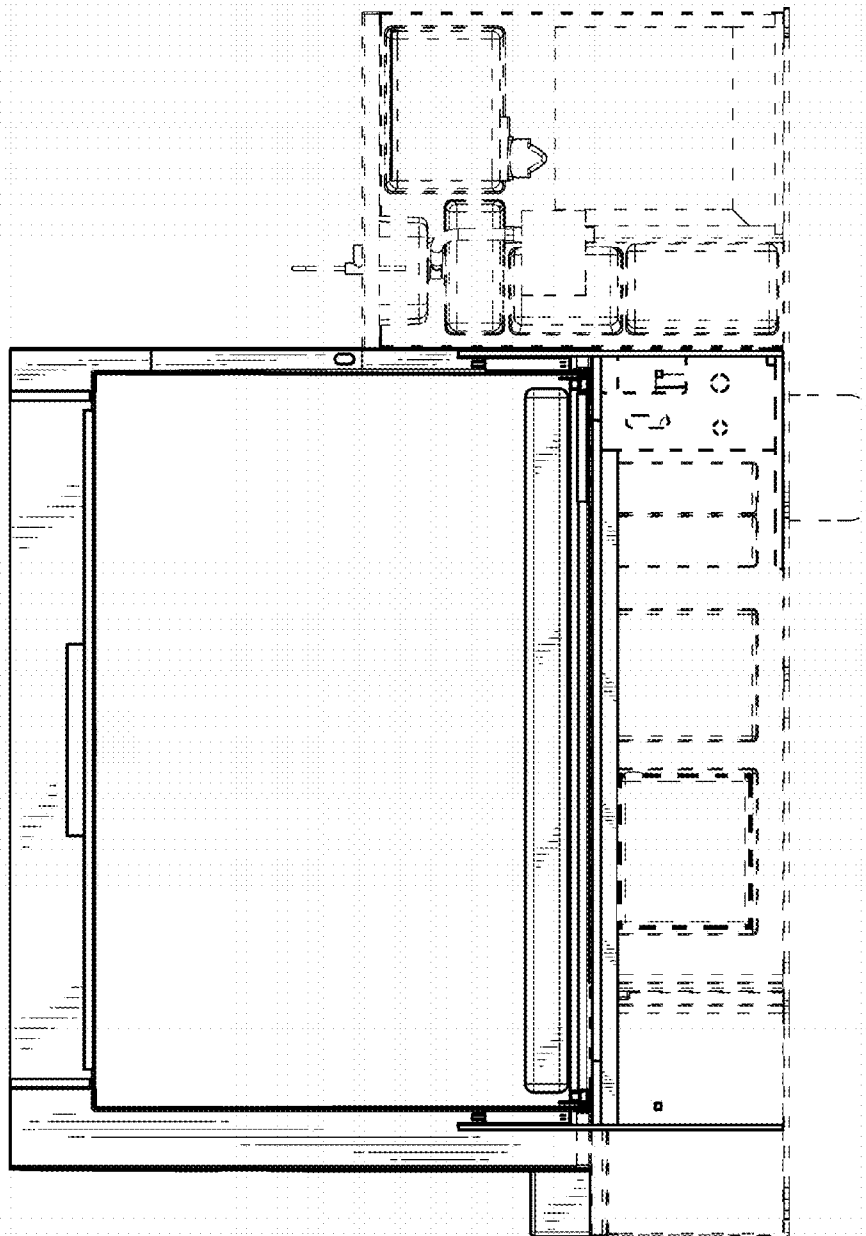

FIGURE 6

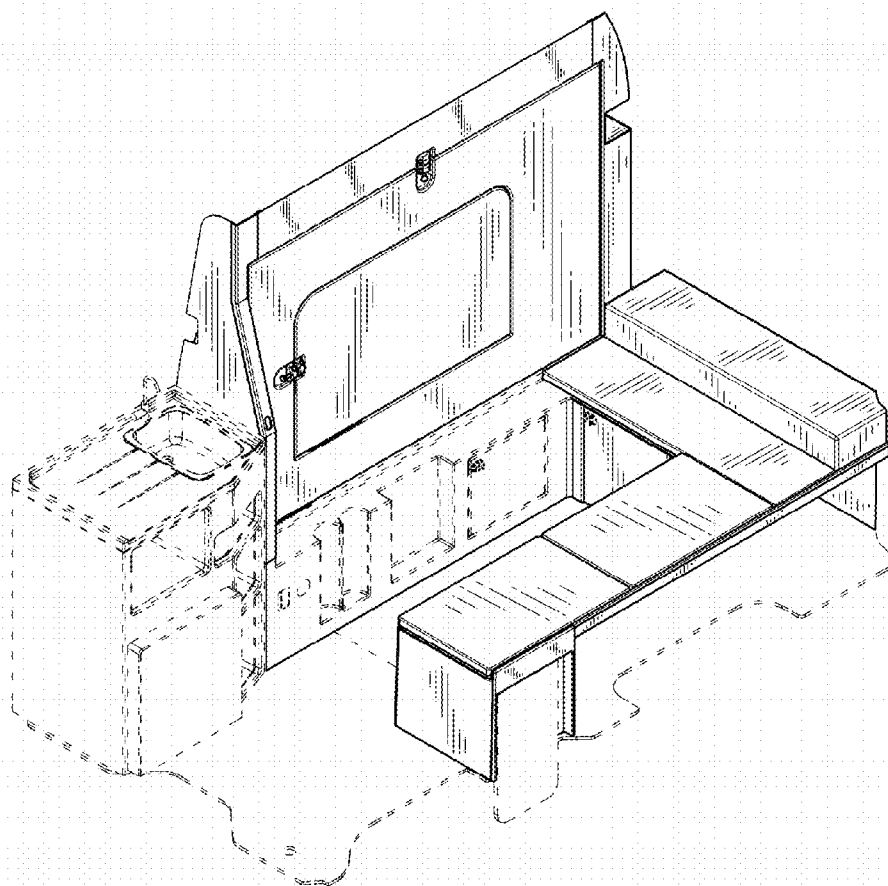

FIGURE 7

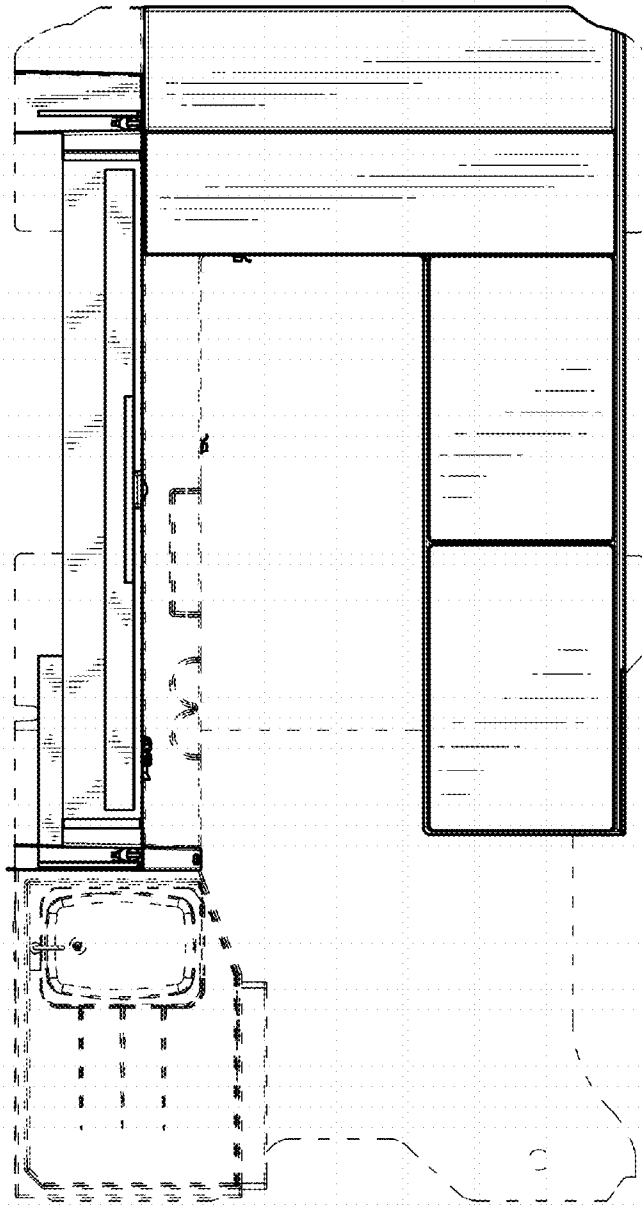

FIGURE 8

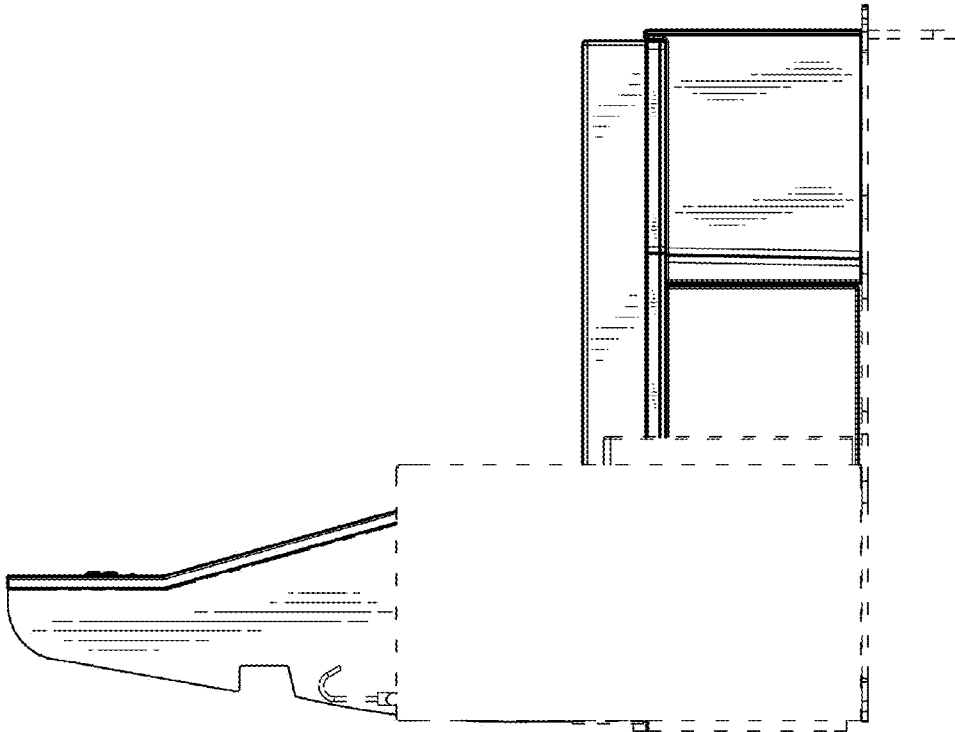

FIGURE 9

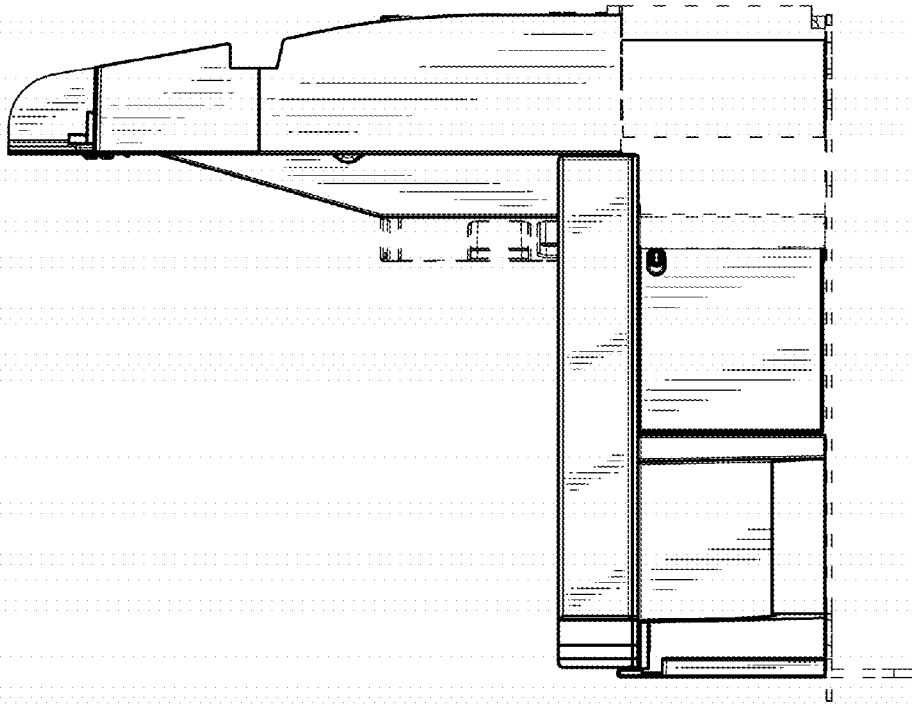

FIGURE 10

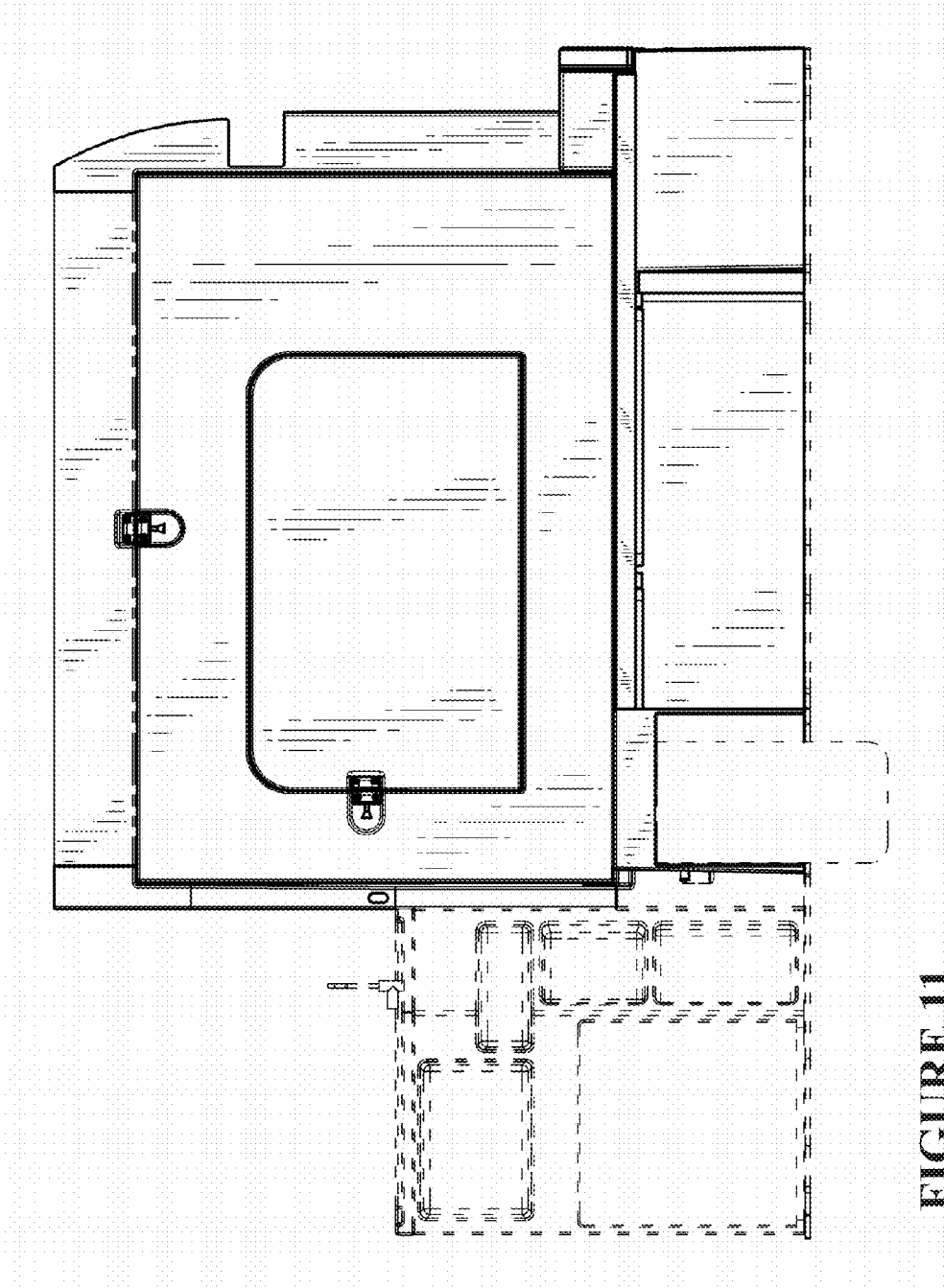

FIGURE 11

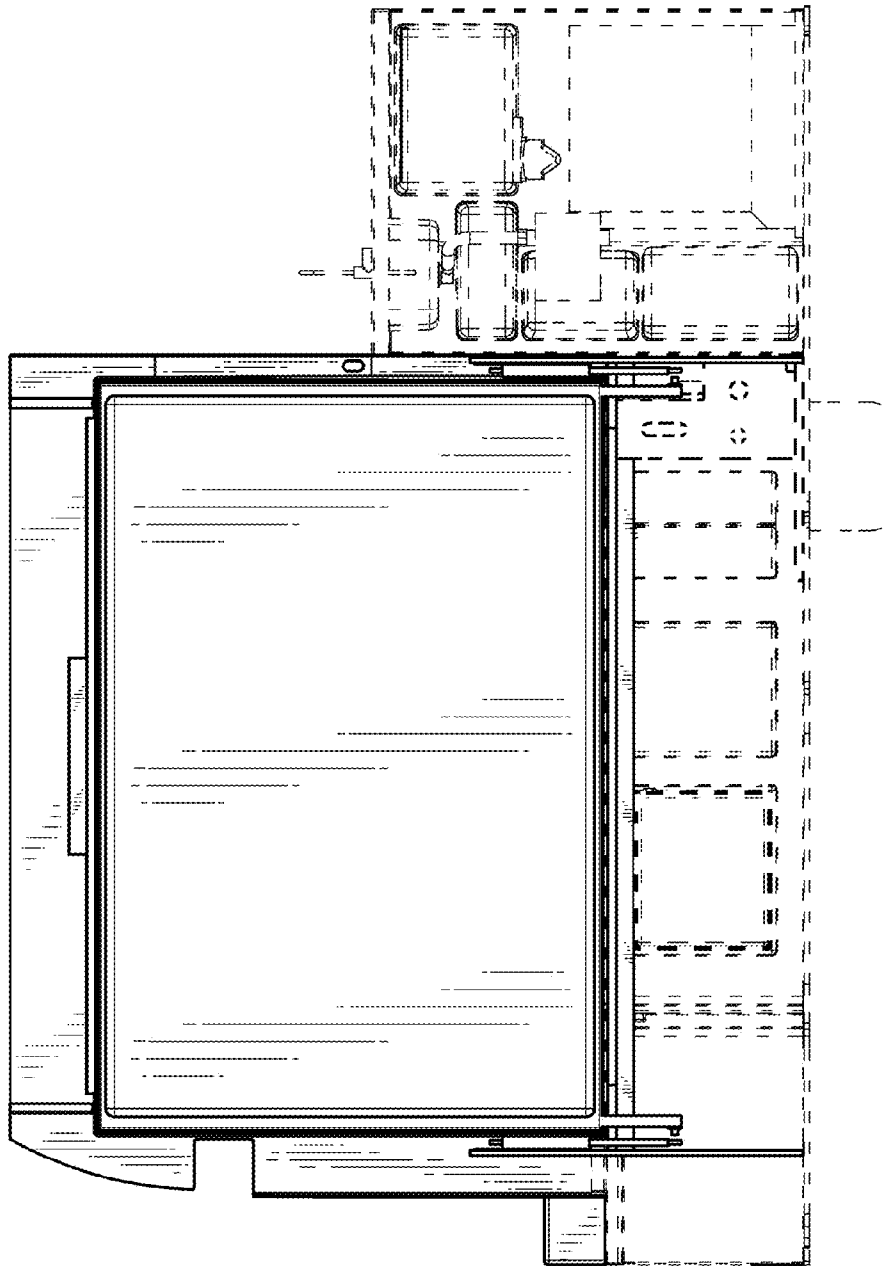

FIGURE 12

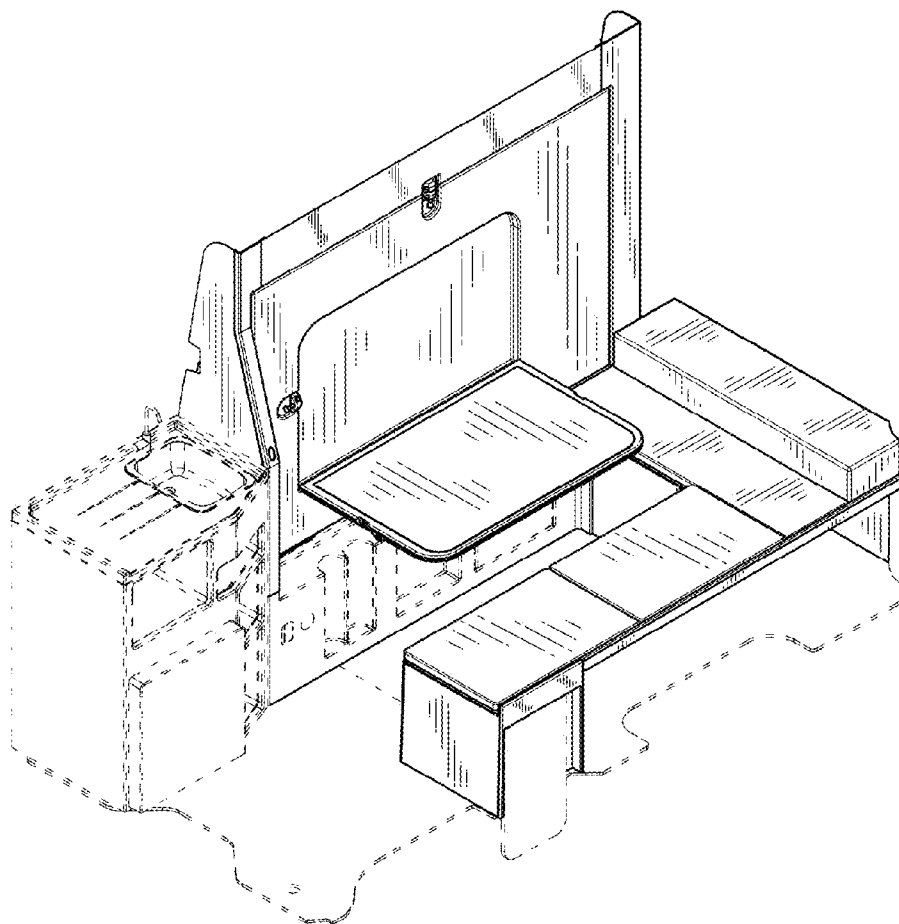

FIGURE 13

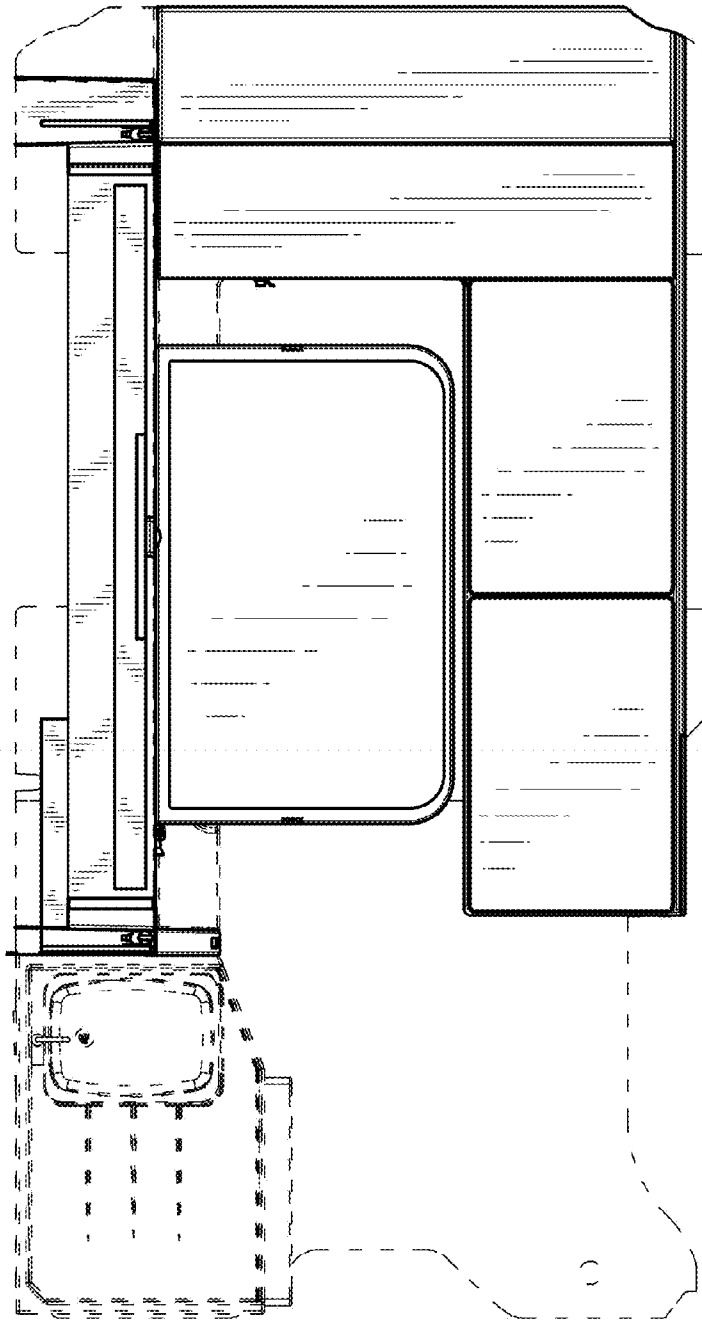

FIGURE 14

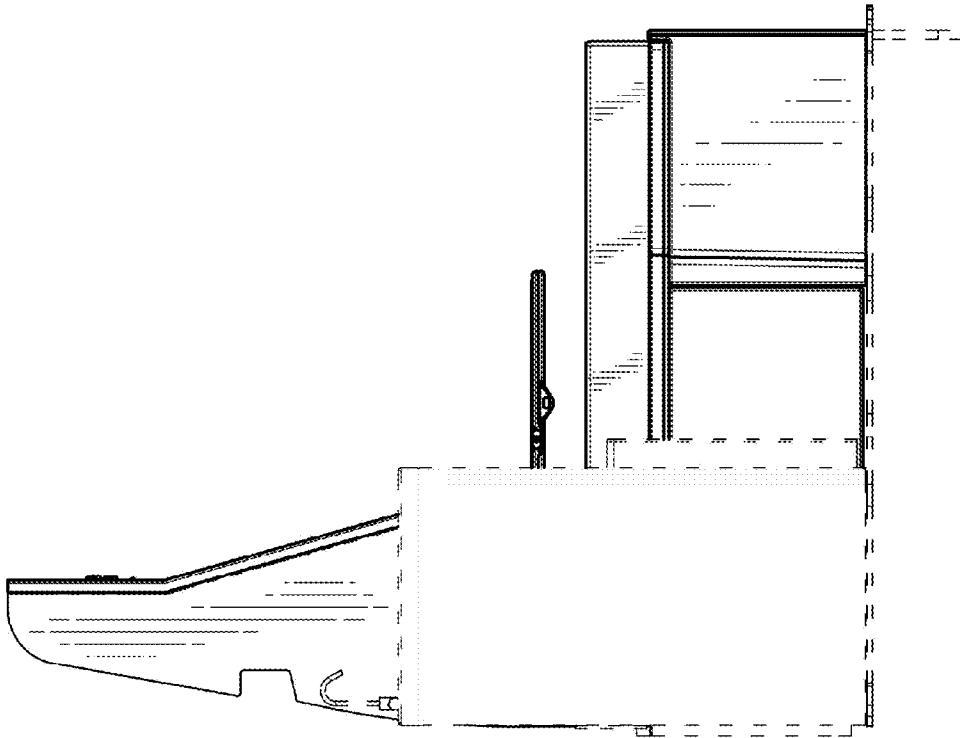

FIGURE 15

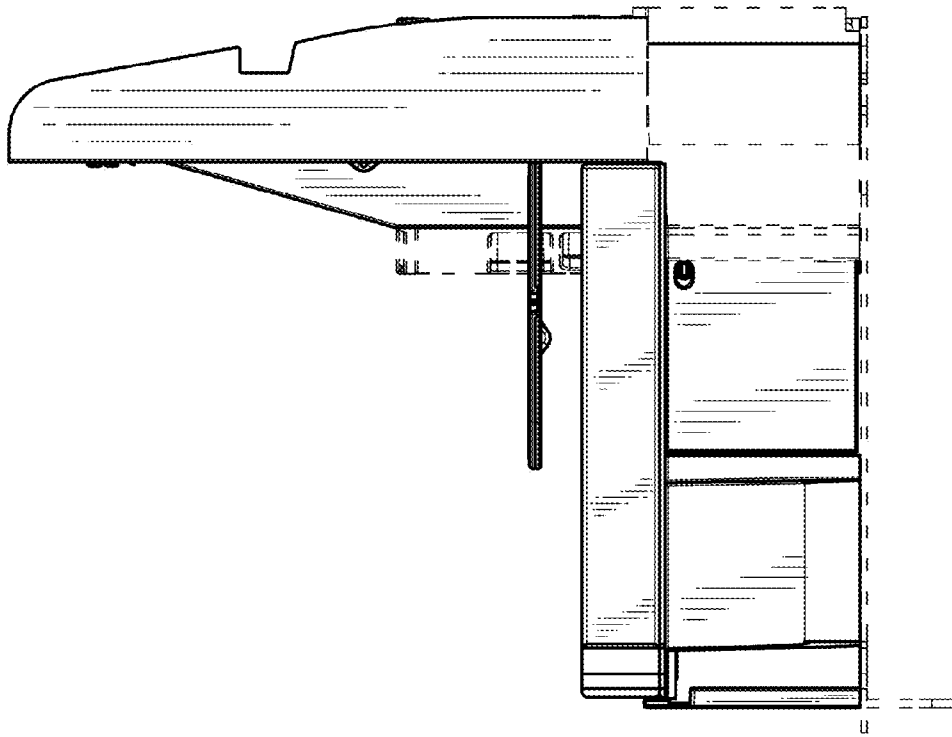

FIGURE 16

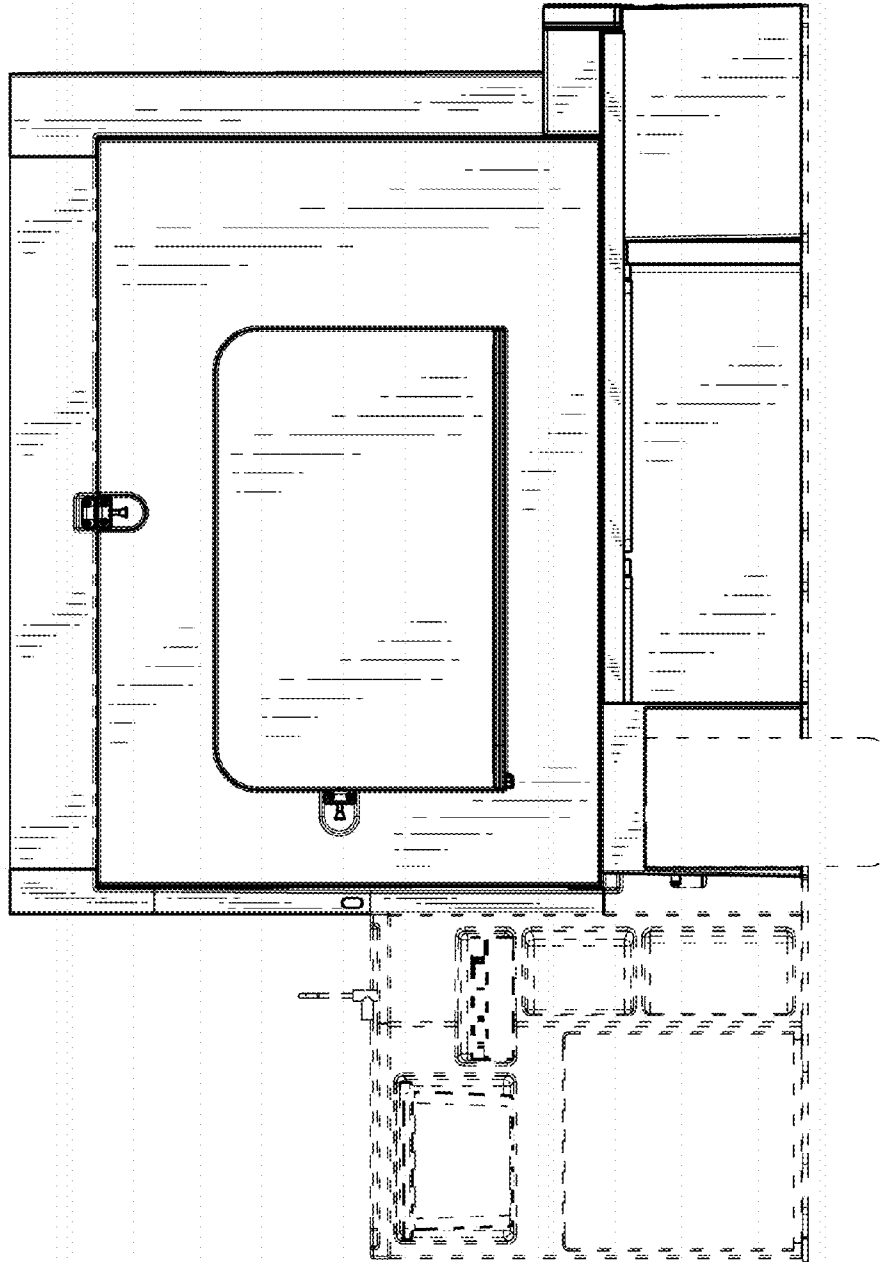

FIGURE 17

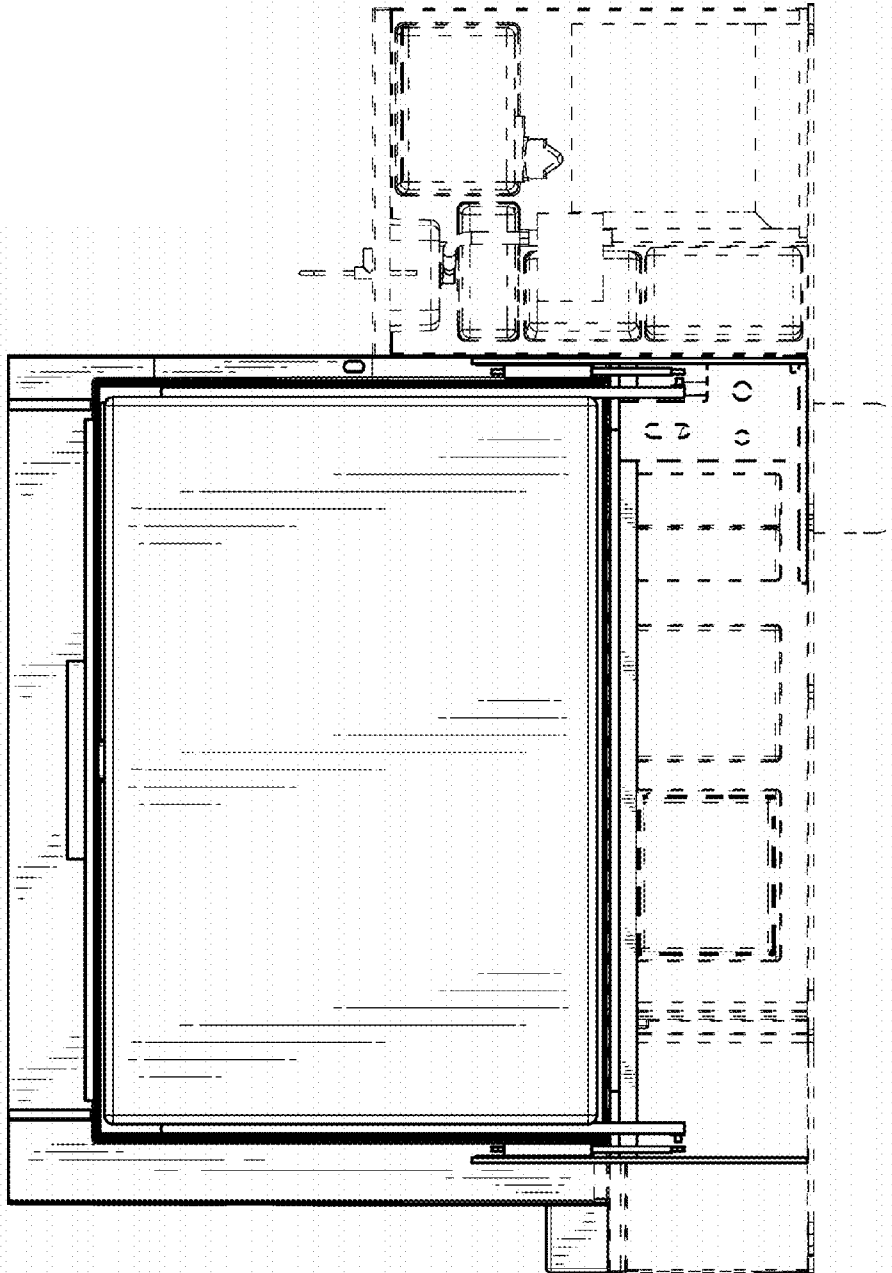

FIGURE 18