



INTERNATIONAL APPLICATION PUBLISHED UNDER THE PATENT COOPERATION TREATY (PCT)

(51) International Patent Classification ⁶ : E21B 43/10, 33/14	A1	(11) International Publication Number: WO 96/22452
		(43) International Publication Date: 25 July 1996 (25.07.96)
<p>(21) International Application Number: PCT/EP96/00265</p> <p>(22) International Filing Date: 15 January 1996 (15.01.96)</p> <p>(30) Priority Data: 95200099.0 16 January 1995 (16.01.95) EP (34) Countries for which the regional or international application was filed: GB et al.</p> <p>(71) Applicant (for all designated States except CA): SHELL INTERNATIONALE RESEARCH MAATSCHAPPIJ B.V. [NL/NL]; Carel van Bylandtlaan 30, NL-2596 HR The Hague (NL).</p> <p>(71) Applicant (for CA only): SHELL CANADA LIMITED [CA/CA]; 400 - 4th Avenue S.W., Calgary, Alberta T2P 2H5 (CA).</p> <p>(72) Inventors: GILL, Daljit, Singh; Volmerlaan 6, NL-2288 GD Rijswijk (NL). LOHBECK, Wilhelmus, Christianus, Maria; Volmerlaan 6, NL-2288 GD Rijswijk (NL). STEWART, Robert, Bruce; Volmerlaan 6, NL-2288 GD Rijswijk (NL). VAN VLIET, Jacobus, Petrus, Maria; Volmerlaan 6, NL-2288 GD Rijswijk (NL).</p>	<p>(81) Designated States: AL, AM, AT, AU, AZ, BB, BG, BR, BY, CA, CH, CN, CZ, DE, DK, EE, ES, FI, GB, GE, HU, IS, JP, KE, KG, KP, KR, KZ, LK, LR, LS, LT, LU, LV, MD, MG, MK, MN, MW, MX, NO, NZ, PL, PT, RO, RU, SD, SE, SG, SI, SK, TJ, TM, TR, TT, UA, UG, UZ, VN, ARIPO patent (KE, LS, MW, SD, SZ, UG), Eurasian patent (AZ, BY, KG, KZ, RU, TJ, TM), European patent (AT, BE, CH, DE, DK, ES, FR, GB, GR, IE, IT, LU, MC, NL, PT, SE), OAPI patent (BF, BJ, CF, CG, CI, CM, GA, GN, ML, MR, NE, SN, TD, TG).</p> <p>Published With international search report.</p>	

(54) Title: METHOD OF CREATING A CASING IN A BOREHOLE

(57) Abstract

The invention relates to a method of creating a casing in a borehole formed in an underground formation. The method comprises the steps of (a) installing a tubular liner (11) in the borehole (1), the liner being radially expandable in the borehole whereby the liner in its radially expanded position has a plurality of openings (12) which are overlapping in the longitudinal direction of the liner, (b) radially expanding the liner in the borehole, and (c) either before or after step (b), installing a body of hardenable fluidic sealing material (13) in the borehole so that the sealing material fills said openings and thereby substantially closes said openings. The sealing material is selected so as to harden in said openings and thereby to increase the compressive strength of the liner.

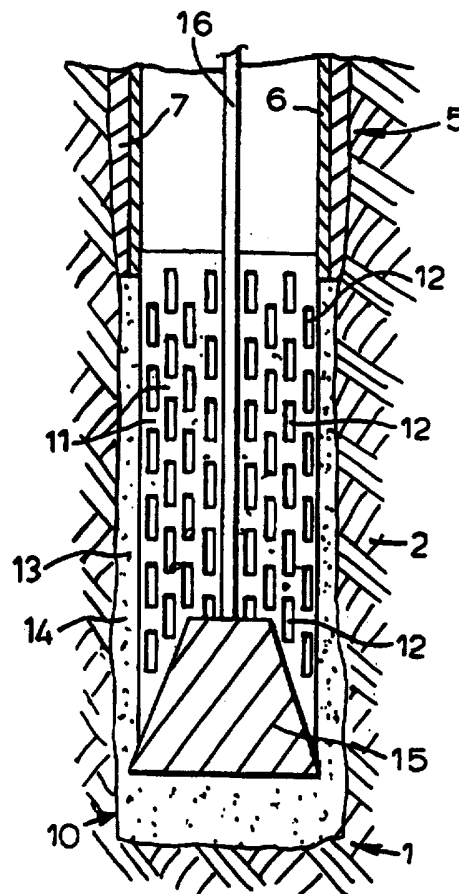

FOR THE PURPOSES OF INFORMATION ONLY

Codes used to identify States party to the PCT on the front pages of pamphlets publishing international applications under the PCT.

AM	Armenia	GB	United Kingdom	MW	Malawi
AT	Austria	GE	Georgia	MX	Mexico
AU	Australia	GN	Guinea	NE	Niger
BB	Barbados	GR	Greece	NL	Netherlands
BE	Belgium	HU	Hungary	NO	Norway
BF	Burkina Faso	IE	Ireland	NZ	New Zealand
BG	Bulgaria	IT	Italy	PL	Poland
BJ	Benin	JP	Japan	PT	Portugal
BR	Brazil	KE	Kenya	RO	Romania
BY	Belarus	KG	Kyrgystan	RU	Russian Federation
CA	Canada	KP	Democratic People's Republic of Korea	SD	Sudan
CF	Central African Republic	KR	Republic of Korea	SE	Sweden
CG	Congo	KZ	Kazakhstan	SG	Singapore
CH	Switzerland	LI	Liechtenstein	SI	Slovenia
CI	Côte d'Ivoire	LK	Sri Lanka	SK	Slovakia
CM	Cameroon	LR	Liberia	SN	Senegal
CN	China	LT	Lithuania	SZ	Swaziland
CS	Czechoslovakia	LU	Luxembourg	TD	Chad
CZ	Czech Republic	LV	Latvia	TG	Togo
DE	Germany	MC	Monaco	TJ	Tajikistan
DK	Denmark	MD	Republic of Moldova	TT	Trinidad and Tobago
EE	Estonia	MG	Madagascar	UA	Ukraine
ES	Spain	ML	Mali	UG	Uganda
FI	Finland	MN	Mongolia	US	United States of America
FR	France	MR	Mauritania	UZ	Uzbekistan
GA	Gabon			VN	Viet Nam

- 1 -

METHOD OF CREATING A CASING IN A BOREHOLE

The invention relates to a method of creating a casing in a borehole formed in an underground formation, the borehole being for example a wellbore for the production of oil, gas or water. Conventionally, when such wellbore is created, a number of casings are installed in the borehole to prevent collapse of the borehole wall and to prevent undesired outflow of drilling fluid into the formation or inflow of fluid from the formation into the borehole. The borehole is drilled in intervals whereby a casing which is to be installed in a lower borehole interval is lowered through a previously installed casing of an upper borehole interval. As a consequence of this procedure the casing of the lower interval is of smaller diameter than the casing of the upper interval. Thus, the casings are in a nested arrangement with casing diameters decreasing in downward direction. Cement annuli are provided between the outer surfaces of the casings and the borehole wall to seal the casings from the borehole wall. As a consequence of this nested arrangement a relatively large borehole diameter is required at the upper part of the wellbore. Such a large borehole diameter involves increased costs due to heavy casing handling equipment, large drill bits and increased volumes of drilling fluid and drill cuttings. Moreover, increased drilling rig time is involved due to required cement pumping and cement hardening.

International patent application WO 93/25799 discloses a method of creating a casing in a section of a borehole formed in an underground formation, wherein a tubular element in the form of a casing is installed within the section of the borehole, and radially expanded

- 2 -

using an expansion mandrel. Expansion of the casing continues until the casing contacts the borehole wall and elastically deforms the surrounding rock formation. Optionally, when washouts occur in the borehole wall during drilling, or when brittle formations are encountered during drilling, cement is pumped in an annular space around the casing at the location of such washout or brittle formation.

Although the known method overcomes the problem of conventional casings whereby the diameter of subsequent casing sections decreases in downward direction, there remains a need for a method of creating a casing in a borehole, whereby a lower load is required to expand the tubular element, and whereby an improved sealing between the casing and the surrounding earth formation is achieved.

In WO 93/25800 is disclosed an application of a production liner in a borehole, which production liner is provided with longitudinally overlapping openings and is radially expanded in the borehole. The production liner serves as a strainer during production of hydrocarbon fluid flowing from the surrounding earth formation through the openings, into the liner. It is essential for this production liner that fluid communication is maintained between the interior of the liner and the surrounding earth formation, i.e. it is essential that the occurrence of a sealing between the production liner and the surrounding formation is avoided. This is contrary to the object of the present invention which is aimed at providing an improved sealing between the casing and the surrounding earth formation. It is another object of the invention to provide a method of creating a casing having an improved collapse resistance. A further object of the invention is to provide a method of creating a casing which allows a smaller difference in

- 3 -

borehole diameter between an upper interval and a lower interval of the borehole.

In accordance with the invention there is provided a method of creating a casing in a borehole formed in an underground formation, the method comprising the steps of:

(a) installing a tubular liner in the borehole, the liner being radially expandable in the borehole whereby the liner during its radial expansion has a plurality of openings which are overlapping in the longitudinal direction of the liner;

(b) radially expanding the liner in the borehole; and

(c) either before or after step (b), installing a body of hardenable fluidic sealing material in the borehole so that the sealing material fills said openings and thereby substantially closes said openings, the sealing material being selected so as to harden in said openings and thereby increasing the compressive strength of the liner.

Thus the method of the invention allows application of casing sections of uniform diameter so that a nested arrangement of subsequent casing sections as in conventional casing schemes can be avoided. With the method of the invention a reliable sealing between the liner and the borehole wall is achieved while the openings of the liner allow a large radial expansion of the liner. After hardening of the sealing material, the liner with the openings filled with sealing material forms a continuous reinforced wellbore casing. The liner is suitably made of steel, and can be provided for example in the form of jointed liner sections or reeled.

Furthermore a significantly lower radial force is required to expand the liner than the force required to expand the solid casing of the known method.

An additional advantage of the method of the invention is that the liner after expansion thereof has a

- 4 -

larger final diameter than the diameter of an expansion tool which is applied. The difference between the permanent final diameter and the largest diameter of the expansion tool is referred to as permanent surplus expansion.

5

Suitably the body of sealing material is installed in the borehole after radially expanding the liner.

Additional strength of the liner is achieved by providing the body of sealing material with reinforcing fibres.

10

In case a part of said body of sealing material remains in the interior of the liner, said part is suitably removed from said interior after expansion of the liner, for example by drilling away said part of the body of sealing material after the sealing material has hardened.

15

The liner can be radially expanded until it contacts the borehole wall, or alternatively until an annular space between the liner and the borehole wall remains whereby the body of hardenable fluidic sealing material extends into said annular space.

20

The invention will be further described by way of example and in more detail with reference to the accompanying drawings, in which:

25

Figure 1 shows schematically a longitudinal cross-section of a borehole having an uncased section that has to be provided with a casing including a liner provided with longitudinally overlapping openings; and

Figure 2 shows part of Figure 1, wherein a part of the liner has been expanded.

30

In Figure 1 is shown the lower part of a borehole 1 drilled in an underground formation 2. The borehole 1 has a cased section 5, wherein the borehole 1 is provided with a casing 6 secured to the wall of the borehole 1 by means of a layer of cement 7, and an uncased section 10.

35

- 5 -

In the uncased section 10 of borehole 1 a steel liner 11 provided with longitudinally overlapping openings has been lowered to a selected position, in this case the end of the casing 6. The openings of the liner have been provided in the form of longitudinal slots 12, so that the liner 11 forms a slotted liner with overlapping longitudinal slots 12. For the sake of clarity not all slots 12 have been provided with a reference numeral. The upper end of the slotted liner 11 has been fixed to the lower end of the casing 6 by means of a suitable connecting means (not shown).

In a next step, a hardenable sealing material in the form of cement mixed with fibers (not shown) is inserted into the slotted liner 11. The cement forms a body of cement 13 in the borehole 1, whereby part of the cement flows through the slots 12 of the liner 11 and around the lower end of the slotted liner 11 into an annular space 14 between the slotted liner 11 and the wall of the borehole 1, and another part of the cement remains in the interior of the slotted liner 11.

Having inserted the cement in the borehole 1, the slotted liner 11 is expanded using an expansion mandrel 15. The slotted liner 11 has been lowered at the lower end of string 16 resting on the expansion mandrel 15. To expand the slotted liner 11 the expansion mandrel 15 is moved upwardly through the slotted liner 11 by pulling on string 16. The expansion mandrel 15 is tapered in the direction in which the mandrel 15 is moved through the slotted liner 11, in this case the expansion mandrel 15 is an upwardly tapering expansion mandrel. The expansion mandrel 15 has a largest diameter which is larger than the inner diameter of the slotted liner 11.

Figure 2 shows the slotted liner 11 in partly expanded form, wherein the lower part of the slotted liner has been expanded. The same features as shown in

- 6 -

Figure 1 have the same reference numerals. The slots deform to openings designated with reference numeral 12'. As the expansion mandrel 15 moves through the slotted liner 11, cement present in the interior of the slotted liner 11 is squeezed by the expansion mandrel 15 through the slots 12 into the annular space 14. Since furthermore the annular space 14 becomes smaller due to the expansion of the liner 11, the cement is squeezed against the wall of the borehole 1, and the expanded liner 11 becomes adequately embedded in the cement.

After the slotted liner 11 has been radially expanded to its full length, the cement of the body of cement 13 is allowed to harden so that a steel reinforced cement casing is achieved, whereby the fibers provide additional reinforcement to the casing. Any part of the body of hardened cement 13 which may remain in the interior of the slotted liner 11 can be removed therefrom by lowering a drill string (not shown) into the slotted liner 11 and drilling away such part of the body of cement 13. The steel reinforced casing thus obtained prevents collapse of the rock formation surrounding the borehole 1 and protects the rock formation from fracturing due to high wellbore pressures which may occur during drilling further (deeper) borehole sections. A further advantage of the steel reinforced cement casing is that the steel liner protects the cement from wear during drilling of such further borehole sections.

Instead of moving the expansion mandrel upwardly through the liner, the expansion mandrel can alternatively be moved downwardly through the liner during expansion thereof. In a further alternative embodiment, a contractible and expandable mandrel is applied. First the liner is lowered in the borehole and subsequently fixed, whereafter the expansion mandrel in contracted form is lowered through the liner. The

- 7 -

expansion mandrel is then expanded and pulled upwardly so as to expand the liner.

The method according to the invention can be applied in a vertical borehole section, a deviated borehole
5 section, or in a horizontal borehole section.

Instead of applying the tapered expansion mandrel described above, an expansion mandrel provided with
10 rollers can be applied, which rollers are capable of rolling along the inner surface of the liner when the mandrel is rotated, whereby the mandrel is simultaneously rotated and axially moved through the liner.

In a further alternative embodiment, the expansion
15 mandrel forms a hydraulic expansion tool which is radially inflated upon provision of a selected fluid pressure to the tool, and whereby step (b) of the method according to the invention comprises providing said selected pressure to the tool.

Any suitable hardenable sealing material can be
20 applied to form the body of sealing material, for example cement, such as conventionally used Portland cement or blast furnace slag cement, or a resin such as an epoxy resin. Also any suitable resin which cures upon contact with a curing agent can be used, for example by providing
25 the liner internally or externally with a first layer of resin and a second layer of curing agent whereby during expansion of the liner the two layers are squeezed into the openings of the liner and become intermixed so that the curing agent induces the resin to cure.

The sealing material can be inserted into the annular
30 space between the liner and the borehole wall by circulating the sealing material through the liner, around the lower end of the slotted liner, and into the annular space. Alternatively the sealing material can be circulated in the reverse direction, i.e. through the

- 8 -

annular space, around the lower end of the liner, and into the liner.

In the foregoing description the liner is provided with a plurality of slots, whereby during radial expansion of the liner the slot widens so as to form the openings. If it is required to pump fluid through the liner before radial expansion thereof, the slots can be sealed before such radial expansion of the liner takes place, for example by means of polyurethane sealing material.

In an alternative embodiment the liner is provided with a plurality of sections of reduced wall-thickness, whereby during radial expansion of the liner each section of reduced wall-thickness shears so as to form one of said openings. For example, each section of reduced wall-thickness can be in the form of a groove provided in the wall of the liner. Preferably each groove extends in the longitudinal direction of the liner.

C L A I M S

1. A method of creating a casing in a borehole formed in an underground formation, the method comprising the steps of:

5 (a) installing a tubular liner in the borehole, the liner being radially expandable in the borehole whereby the liner during its radial expansion has a plurality of openings which are overlapping in the longitudinal direction of the liner;

(b) radially expanding the liner in the borehole; and

10 (c) either before or after step (b), installing a body of hardenable fluidic sealing material in the borehole so that the sealing material fills said openings and thereby substantially closes said openings, the sealing material being selected so as to harden in said openings and thereby increasing the compressive strength of the liner.

15 2. The method of claim 1, wherein the body of sealing material is installed in the borehole after radially expanding the liner.

20 3. The method of claim 1 or 2, wherein the body of sealing material is provided with reinforcing fibres which reinforce the sealing material after hardening thereof.

25 4. The method of any of claims 1-3, wherein a part of said body of sealing material extends in the interior of the liner, which part is removed from said interior of the liner by rotating a drill string inside the expanded liner.

30 5. The method of any of claims 1-4, wherein the liner is radially expanded using an expansion mandrel having a largest diameter larger than the inner diameter of the

- 10 -

liner before expansion thereof, whereby the mandrel is axially moved through the liner.

5 6. The method of claim 5, wherein the mandrel is provided with rollers which roll along the inner surface of the liner when the mandrel is rotated in the liner, and whereby the mandrel is simultaneously rotated and axially moved through the liner.

10 7. The method of claim 5, wherein the expansion mandrel forms a hydraulic expansion tool which radially inflates upon provision of a selected fluid pressure to the tool and thereby radially expands the liner.

15 8. The method of any of claims 1-7, wherein the hardenable sealing material is selected from the group of cement, Portland cement, blast furnace slag cement, resin, epoxy resin and resin which cures upon contact with a curing agent.

20 9. The method of any of claims 1-8, wherein the liner is provided with a plurality of sections of reduced wall-thickness, whereby during radial expansion of the liner each section of reduced wall-thickness shears so as to form one of said openings.

10. The method of claim 9, wherein each section of reduced wall-thickness forms a groove provided in the wall of the liner.

25 11. The method of claim 10, wherein each groove extends in the longitudinal direction of the liner.

30 12. The method of any of claims 1-8, wherein the liner is provided with a plurality of slots, whereby during radial expansion of the liner each slot widens so as to form one of said openings.

13. The method of claim 12, wherein said slots extend in longitudinal direction of the liner.

35 14. The method of claim 12 or 13, wherein before radial expansion of the liner the slots are sealed so as to allow fluid to be induced to flow through the liner.

- 11 -

15. The method of claim 14, wherein the slots are sealed by polyurethane sealing material.

5 16. The method of any of claims 1-15, wherein after radially expanding the liner in the borehole an annular space remains between the liner and the borehole wall, whereby the body of hardenable fluidic sealing material extends into said annular space.

17. The method substantially as described hereinbefore with reference to the drawings.

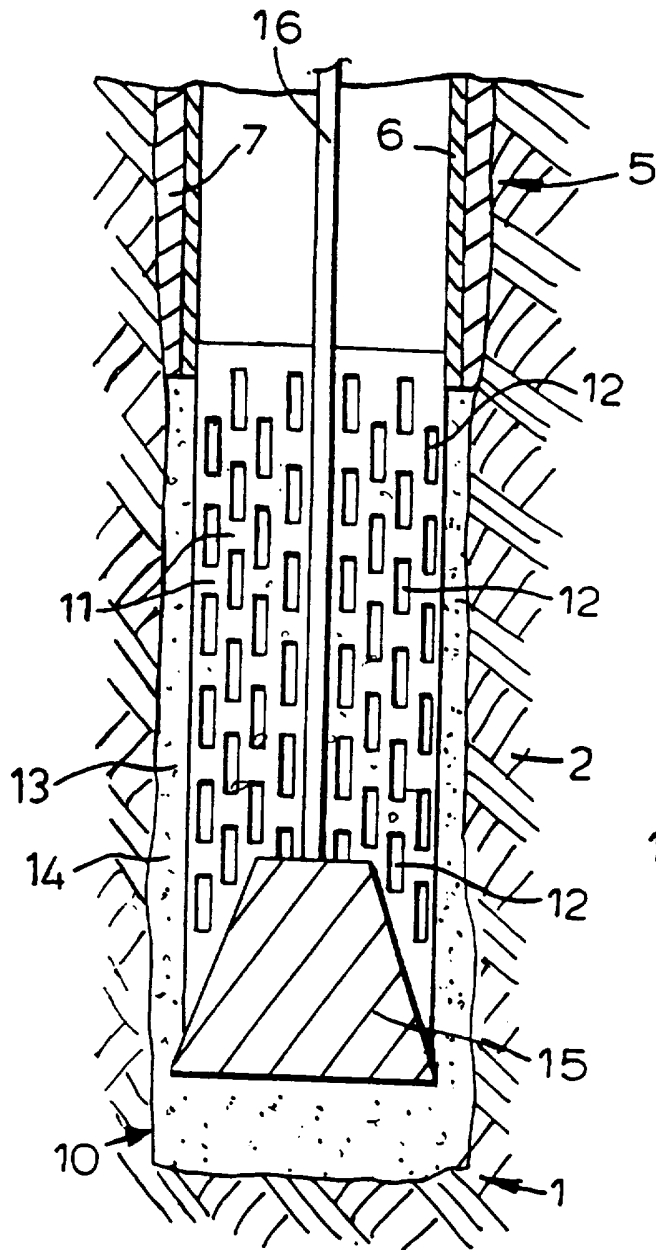

FIG. 1

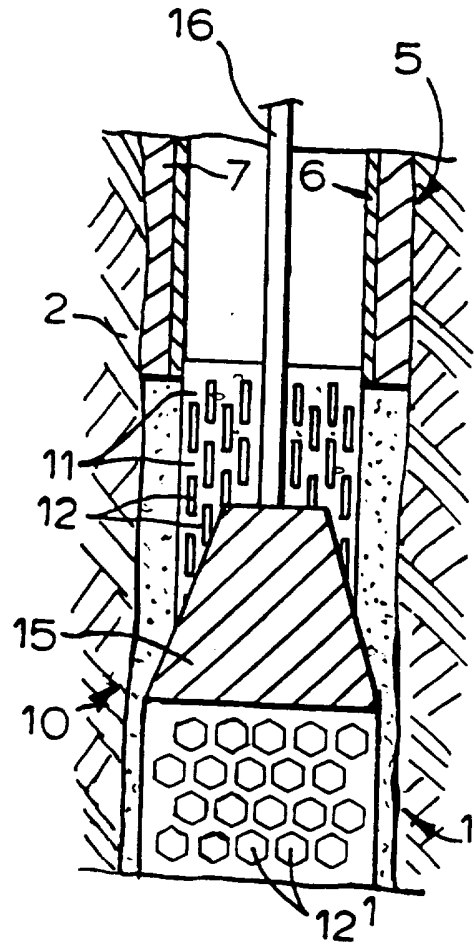

FIG. 2

INTERNATIONAL SEARCH REPORT

Intern: d Application No
PCT/EP 96/00265

A. CLASSIFICATION OF SUBJECT MATTER
IPC 6 E21B43/10 E21B33/14

According to International Patent Classification (IPC) or to both national classification and IPC

B. FIELDS SEARCHED

Minimum documentation searched (classification system followed by classification symbols)

IPC 6 E21B

Documentation searched other than minimum documentation to the extent that such documents are included in the fields searched

Electronic data base consulted during the international search (name of data base and, where practical, search terms used)

C. DOCUMENTS CONSIDERED TO BE RELEVANT

Category *	Citation of document, with indication, where appropriate, of the relevant passages	Relevant to claim No.
A	WO,A,93 25800 (SHELL INTERNATIONALE RESEARCH MAATSCHAPPIJ) 23 December 1993 cited in the application see claim 1 ---	1
A	WO,A,93 25799 (SHELL INTERNATIONALE RESEARCH MAATSCHAPPIJ) 23 December 1993 cited in the application see abstract ---	1
A	US,A,3 175 618 (LANG) 30 March 1965 see column 1, line 66 - line 69 see column 2, line 23 - line 35 ---	1
A	US,A,3 052 298 (MALOTT) 4 September 1962 see claim 1 ---	1
	-/--	

Further documents are listed in the continuation of box C.

Patent family members are listed in annex.

* Special categories of cited documents :

- "A" document defining the general state of the art which is not considered to be of particular relevance
- "E" earlier document but published on or after the international filing date
- "L" document which may throw doubts on priority claim(s) or which is cited to establish the publication date of another citation or other special reason (as specified)
- "O" document referring to an oral disclosure, use, exhibition or other means
- "P" document published prior to the international filing date but later than the priority date claimed

- "T" later document published after the international filing date or priority date and not in conflict with the application but cited to understand the principle or theory underlying the invention
- "X" document of particular relevance; the claimed invention cannot be considered novel or cannot be considered to involve an inventive step when the document is taken alone
- "Y" document of particular relevance; the claimed invention cannot be considered to involve an inventive step when the document is combined with one or more other such documents, such combination being obvious to a person skilled in the art.
- "&" document member of the same patent family

Date of the actual completion of the international search 29 April 1996	Date of mailing of the international search report 09.05.96
--	--

Name and mailing address of the ISA European Patent Office, P.B. 5818 Patentlaan 2 NL - 2280 HV Rijswijk Tel. (+ 31-70) 340-2040, Tx. 31 651 epo nl, Fax: (+ 31-70) 340-3016	Authorized officer Sogno, M
--	------------------------------------

INTERNATIONAL SEARCH REPORT

Intern. Application No
PCT/EP 96/00265

C.(Continuation) DOCUMENTS CONSIDERED TO BE RELEVANT		
Category *	Citation of document, with indication, where appropriate, of the relevant passages	Relevant to claim No.
A	US,A,5 240 074 (PEAVY) 31 August 1993 see column 5, line 43 - line 56 ---	1
A	US,A,2 207 478 (CAMERON) 9 July 1940 see claim 1 ---	1
A	US,A,4 495 997 (SCOTT) 29 January 1985 see abstract -----	1

INTERNATIONAL SEARCH REPORT

Information on patent family members

International Application No

PCT/EP 96/00265

Patent document cited in search report	Publication date	Patent family member(s)	Publication date
WO-A-9325800	23-12-93	AU-B- 4324593	04-01-94
		CA-A- 2137565	23-12-93
		EP-A- 0643795	22-03-95
		JP-T- 7507611	24-08-95
		NO-A- 944746	03-02-95
		NZ-A- 253125	27-02-96
		US-A- 5366012	22-11-94

WO-A-9325799	23-12-93	AU-B- 4324493	04-01-94
		CA-A- 2137560	23-12-93
		EP-A- 0643794	22-03-95
		JP-T- 7507610	24-08-95
		NO-A- 944721	07-12-94
		NZ-A- 253124	27-02-96
		US-A- 5348095	20-09-94

US-A-3175618	30-03-65	NONE	

US-A-3052298	04-09-62	NONE	

US-A-5240074	31-08-93	NONE	

US-A-2207478	09-07-40	NONE	

US-A-4495997	29-01-85	CA-A- 1210318	26-08-86
