

J. P. WEIS.
 TRIMMING MECHANISM FOR SEWING MACHINES.
 APPLICATION FILED MAR. 6, 1903.

996,383.

Patented June 27, 1911.

4 SHEETS—SHEET 1.

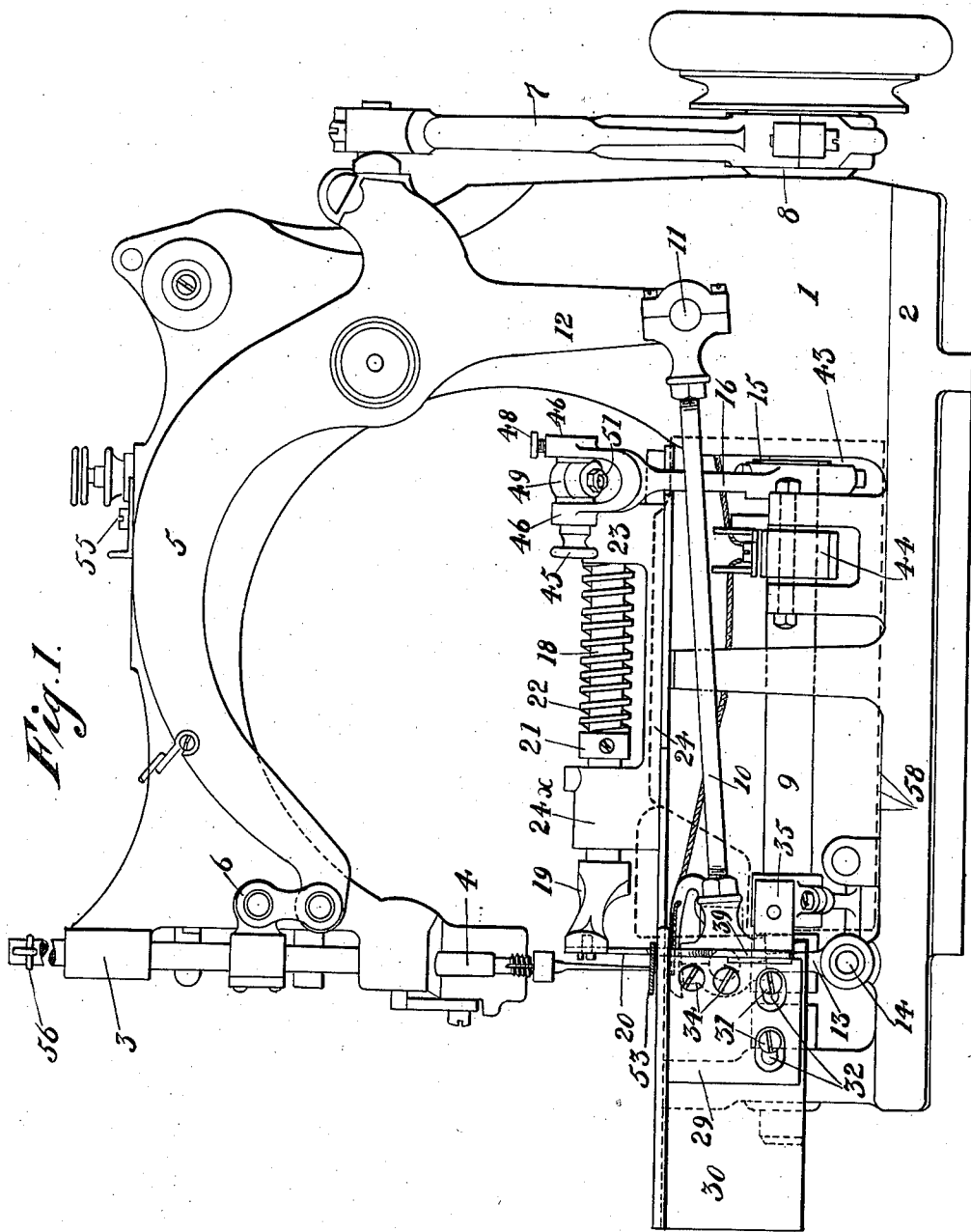

Fig. 1.

WITNESSES:

John Harding
W. B. Hoare.

INVENTOR:

John P. Weis.
 BY
Chas. M. C. Chapman.
 ATTORNEY.

J. P. WEIS.
 TRIMMING MECHANISM FOR SEWING MACHINES.
 APPLICATION FILED MAR. 6, 1903.

996,383.

Patented June 27, 1911.

4 SHEETS—SHEET 2.

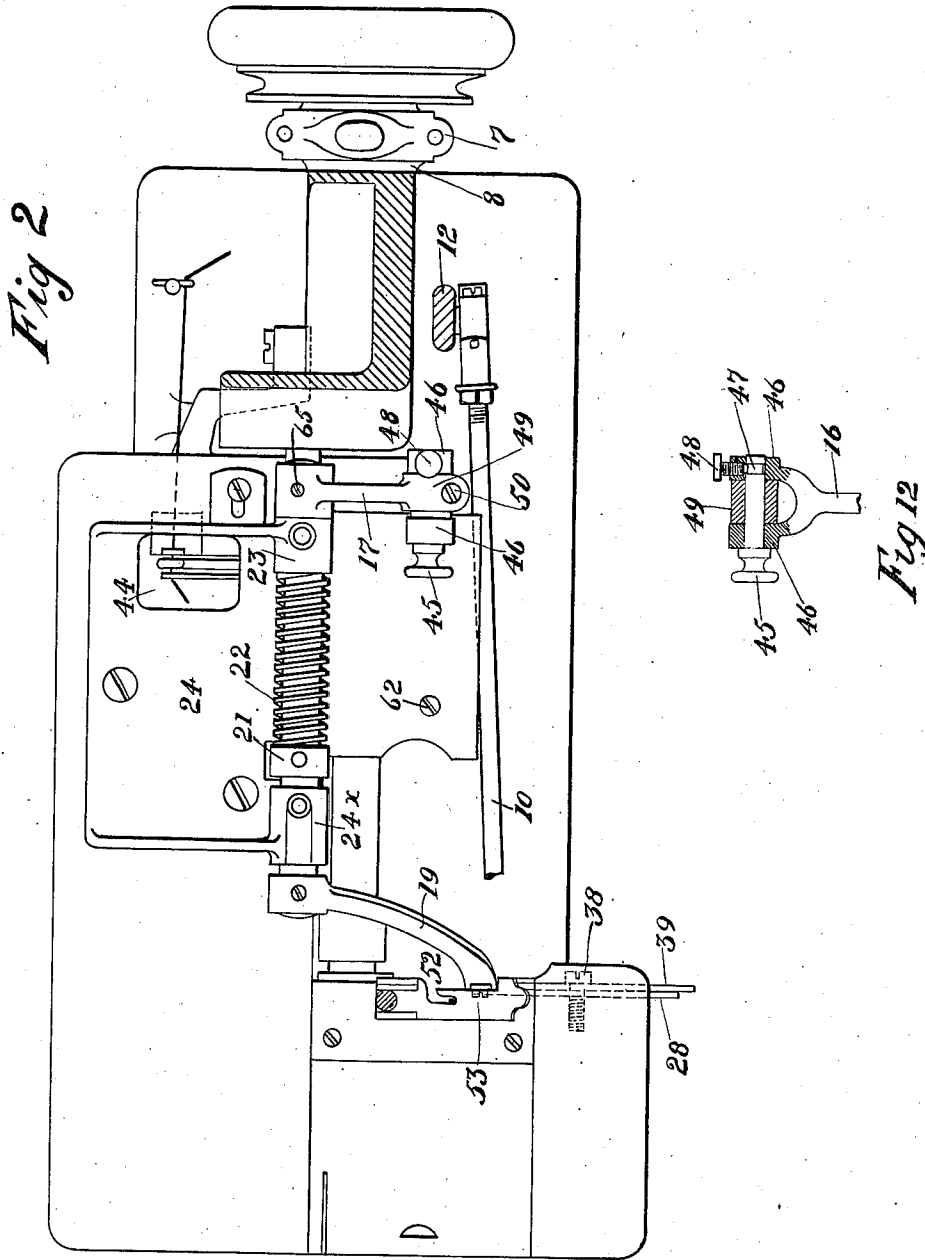

WITNESSES:

M. Harding
W. B. Hoare

INVENTOR:

John P. Weis.
 BY
Chas. M. C. Chapman.
 ATTORNEY.

J. P. WEIS.
 TRIMMING MECHANISM FOR SEWING MACHINES.
 APPLICATION FILED MAR. 6, 1903.

996,383.

Patented June 27, 1911.

4 SHEETS—SHEET 3.

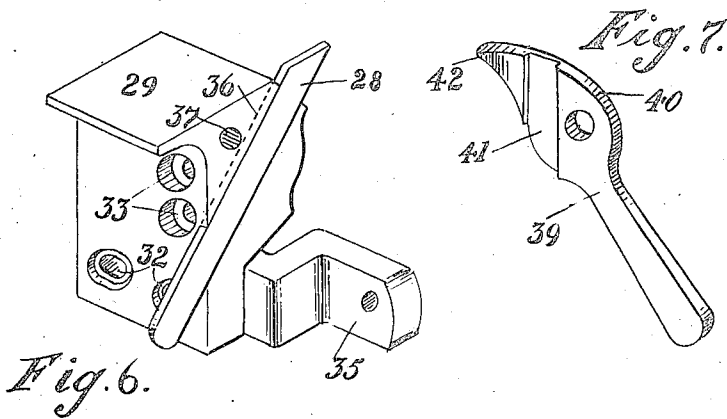
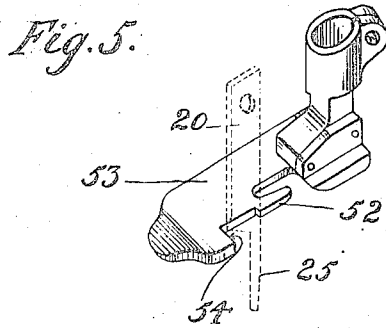
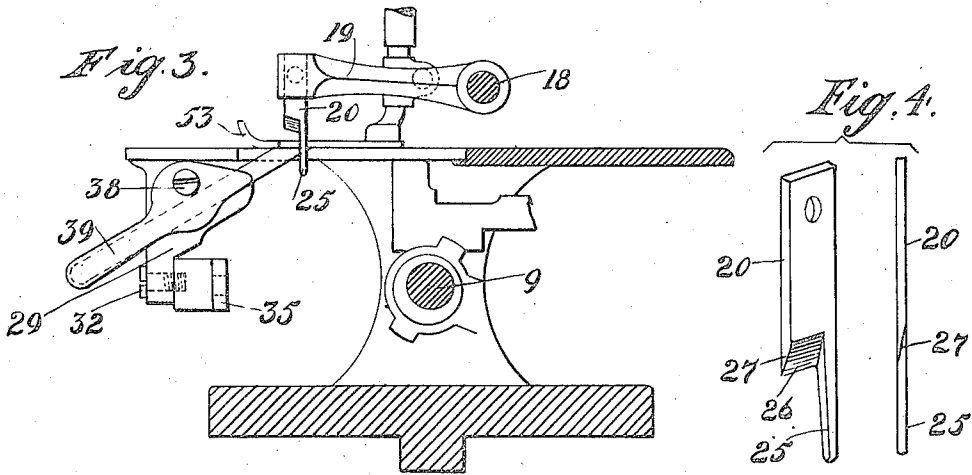

WITNESSES:

J. M. Waidong
W. B. Hoare

INVENTOR:

John P. Weis
 BY
Chas. M. C. Chapman
 ATTORNEY.

J. P. WEIS.

TRIMMING MECHANISM FOR SEWING MACHINES.

APPLICATION FILED MAR. 6, 1903.

Patented June 27, 1911.

4 SHEETS-SHEET 4.

996,383.

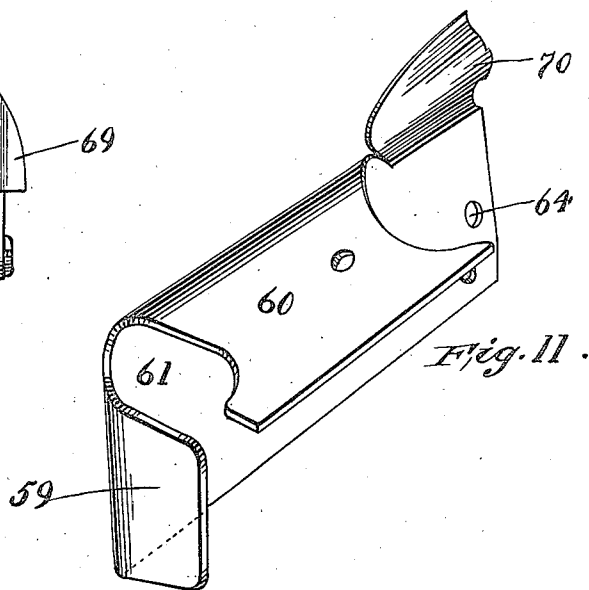
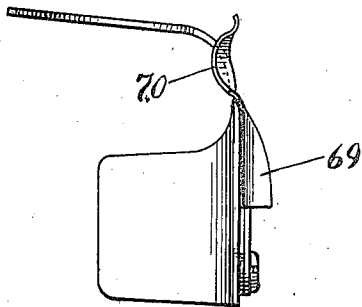
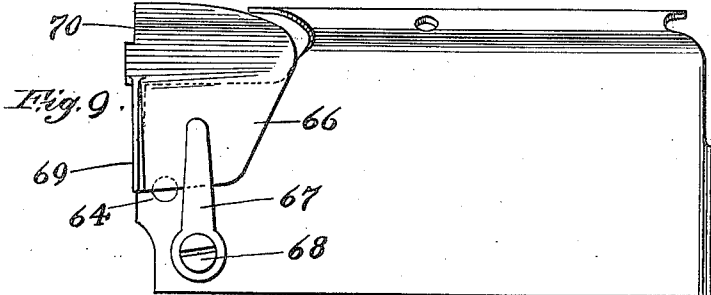
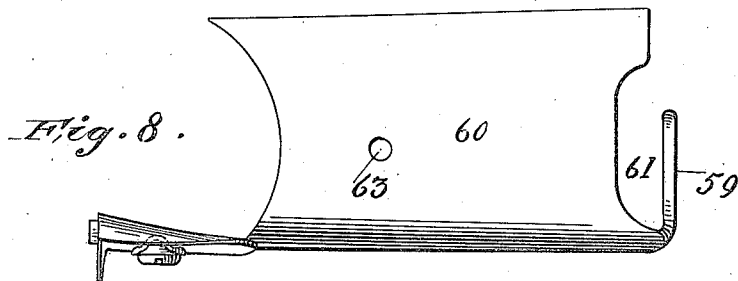

WITNESSES:

E. M. Benjamin
M. B. Hoare

INVENTOR:

John P. Weis.
BY
Chas. M. C. Chapman.
ATTORNEY.

UNITED STATES PATENT OFFICE.

JOHN P. WEIS, OF BROOKLYN, NEW YORK, ASSIGNOR, BY MESNE ASSIGNMENTS, TO METROPOLITAN SEWING MACHINE COMPANY, A CORPORATION OF NEW YORK.

TRIMMING MECHANISM FOR SEWING-MACHINES.

996,383.

Specification of Letters Patent. Patented June 27, 1911.

Application filed March 6, 1903. Serial No. 146,431.

To all whom it may concern:

Be it known that I, JOHN P. WEIS, a citizen of the United States, residing in Brooklyn, county of Kings, and State of New York, have invented a new and useful Improvement in Trimming Mechanism for Sewing-Machines, of which the following is a description.

This invention relates to sewing machines, and more particularly to machines for sewing and trimming simultaneously. Specially, the trimming mechanism is constructed for the purpose of trimming in advance of the sewing mechanism, which may be and preferably is, overedging mechanism. And it is understood that this machine is constructed for the purpose of operating upon all kinds of goods, viz., knit or other elastic goods, flannel, leather, gloves, hat-sweats and various other articles and materials.

It is an object of my invention to provide a trimming mechanism which can be adapted to any type of overedge machine without altering the same in any material particular, and therewith produce even and uniform work and provide the edge or edges of fabric with a perfect and ornamental selvage.

It is a further object of my invention to provide a mechanism for trimming the edges of the material operated upon, which can be accurately adjusted and caused to operate effectively with very little manipulation.

With the several objects above set forth in view, and others to be hereafter noted, the invention consists in the parts, features, and mechanism hereinafter described and claimed.

In the drawings: Figure 1 shows a sewing machine in front elevation, the same having my trimming mechanism applied thereto; Fig. 2 shows the machine in plan, the over-hanging arm, head and cover plate of the machine being removed and the vertical arm being in section, and the stitching mechanism being omitted to clearly show the trimming mechanism; Fig. 3 is a sectional view of a portion of the machine, showing in elevation the coöperative relation of the trimmer-blades and the presser-foot; Fig. 4 shows in perspective and in front-edge elevation, the upper trimmer-blade; Fig. 5 shows in perspective the presser-foot, and the upper trimmer-blade in dotted lines adjacent thereto; Fig. 6 is a perspective of the lower blade, its holder and the bracket to

which the latter is attached; Fig. 7 is a perspective of the cam-lever for holding the lower trimmer-blade firmly in place; Figs. 8 to 11 illustrate the cover-plate, employed for covering the several operative parts below the cloth-plate, Fig. 8 being a top-plan, Fig. 9 a front elevation, Fig. 10 a front end elevation, and Fig. 11 a perspective looking at said plate from the rear and from slightly above the same; and Fig. 12 is a sectional view showing details of the coupling between the trimmer and its actuating mechanism.

The frame of the machine is indicated by 1; the bed-plate by 2; the head of the machine by 3; the needle-bar by 4; the needle-bar operating lever by 5, connected to said bar by a link 6, and actuated by an eccentric strap 7, the latter being actuated by the eccentric 8, on the driving shaft 9. The looper is given its loop-taking movement by a pitman 10, actuated by a crank pin 11, carried by the depending arm 12, of the needle-bar operating lever. At its forward end the pitman 10, is connected to the looper-carrier 13, mounted upon the rock-shaft 14, which latter is given a longitudinal reciprocation transversely of the bed-plate in any suitable manner, such reciprocation giving to the looper its lateral vibration. The needle carries the first and the looper the second thread of the machine. For overedging, a spreader may be provided to manipulate the looper thread and carry it over the edge of the work into position for entrance by the needle in its descent. This is a usual construction and has not been illustrated to avoid confusion of parts thereof with the trimming mechanism.

The trimmer mechanism is actuated from an eccentric 15, carried by the driving-shaft and surrounded by the eccentric-strap 16, connected to an arm 17, as hereinafter described, and carried by a rock-shaft 18, having at its forward end a crank-arm 19, adjustably secured thereto by suitable screws and carrying at its forward end, in any suitable manner, a trimmer-blade 20. The rock-shaft 18, carries an adjustable collar 21, which suitably compresses a spring 22, between it and a bearing 23, of the trimmer-bracket or frame 24. The rock-shaft 18, is of a length sufficient to enable considerable clearance between the trimmer-blade carrier 19, and the bearing 24, for a purpose hereinafter described. The details of the trim-

mer-blade and the remaining complemental parts of the trimming mechanism, are best shown on Sheet 3 of the drawings. The trimmer-blade 20, Fig. 4, is provided with a long, depending finger 25, and a cutting edge 26, properly beveled as shown at 27. The finger 25, extends below the cloth-plate of the machine and rests easily against the side of the lower-blade 28, as shown clearly in Fig. 3. The trimmer-blade also works in a groove, or cut-out portion, of the presser-foot as hereafter described. The lower-blade is properly guided, held and secured in a bracket 29, adjustably secured to a portion of the front web 30, depending from the cloth-plate of the machine, Figs. 1 and 3. The bracket 29, may be any shape suitable for attachment to the web 30, by means of screws 31, entering elongated slots 32, so that proper lateral adjustment may be obtained. The bracket 29, is also provided with one or more apertures 33, for the reception of screws 34, whereby to securely fasten the bracket 29, to the web 30, the latter being also extended angularly for the purpose of forming a support 35, for the cover-plate, as hereafter described. The lower blade 28, is of any suitable shape, and its shank is guided and held in a groove 36, in the bracket 29, said groove being open at one side and extending obliquely across the bracket from the middle of the face thereof to the rear thereof at the top. Slightly above the said groove 36, is formed an aperture 37, for the reception of a pivotal screw 38, which forms the fulcrum of the cam-lever 39, which binds the lower blade in place. The lever 39, consists of a body portion 40, having a diametrical groove 41, for easement of the lower-blade when the same is to be adjusted or removed, and is also provided with a slightly curved and thickened finger or projection 42, which impinges upon and tightly holds the lower blade in place when the lever is in the operative position illustrated in Fig. 3. Manipulation of the lever 39, is accomplished through the medium of its elongated handle, and said lever is supported by the screw 38, which freely enters the aperture 37. When the lever 39, is in the position of Fig. 3, the groove 41, extends transversely of the blade 28; but when it is desired to remove the blade 28, the lever is lifted, its finger 42, is depressed and carried from contact with the blade 28, and its groove 41, is caused to parallel said blade, thereby providing easement of the latter and permitting ready adjustment or withdrawal.

The arm 17, of the rock-shaft 18, is connected to the eccentric strap 16, by means of the accessibly presented or located removable bolt 45, which passes through apertures in the prongs 46, 46, of said strap 16, and through an aperture,—suitably formed,—

in the end of the arm 17. The bolt has a circular groove 47, in its end, entered by the rounded end of an adjusting-screw 48, passing down through one of the prongs 46. This makes a removable connection and permits of the upper blade being turned up out of operative position as well as of adjustment of the trimming mechanism, and of the strap 16, on its eccentric, a clearance 43, being provided between the latter and the frame of the machine for such adjustment, as hereinafter noted. Preferably, the aperture in the end of arm 17, is made through an enlarged, split portion 49, which may be clamped upon the bolt 45, by means of the screw 50, and holding nut 51.

The throat-plate of the machine is provided with a free-ended tongue, as is usual in overedge machines, which lies directly under a similar tongue 52, carried by the presser-foot 53, which latter is also provided with an angular notch 54, in its side in rear of said tongue 52, for the proper positioning of the trimmer-blade 20, relatively to the edge of the work to be operated upon.

Any form of take-up, pull-off and tension device may be employed to properly handle and control the several threads. In the drawings I have illustrated parts only of an ordinary take-up and pull-off at 44, for the lower threads, and at 55, an ordinary tension for the upper thread, the stitch being set by the ordinary thread-eye take-up 56, on the needle-bar.

The operating mechanism below the cloth-plate may be disclosed by removing the cover-plate, Fig. 1 showing the latter removed, but indicating its position by heavy dotted line 58. The cover-plate has the end portion 59, the top portion 60, leaving between them the opening 61, through which extends the pitman connection from the arm of the needle-operating lever to the looper, and the top portion being of a width and length sufficient to practically cover the mechanism below the cloth-plate between the middle thereof and the front of the machine. A screw 62, Fig. 2, is provided for passage through an aperture 63, in the top portion 60, and the forward end of the latter being curved so as to leave an opening through which the spreader may operate and also through which any adjustments, found necessary, may be made. The forward end of the cover-plate is provided with an aperture 64, through which a screw may be passed for securing the same to the bracket 35, of the web portion 30, of the cloth-plate or frame. At the forward end the cover-plate is provided with a pivotally supported guard-plate 66, held firmly in place in the position shown in Fig. 9, by means of a spring 67, pivoted to the cover-plate by the screw 68. The spring is secured in any

suitable manner to the guard-plate 66. Said plate 66, is provided at its front edge with an angular guard portion 69, the forward edge of which is suitably curved and gradually develops into a concavo-convexed shunt or deflecting portion 70, extending along the top of the plate 66. This particular shape of the guard-plate is of importance only in so far as it affords a means for deflecting the trimmed edge or waste portion, of the material operated upon, away from the feeding and stitch-forming mechanisms; and the concavo-convexed portion 70, is for the purpose of suitably turning away or deflecting the trimmed edge, while the angular portion 69, is for the purpose of preventing said trimmed edge from dangling in a manner to interfere with the operating mechanism of the machine.

The feeding mechanism may be of any suitable character.

The operation of the machine is as follows: The needle is confined to a vertical reciprocation; the looper has a longitudinal reciprocation and a lateral vibration; and the spreader, as is usual, has a longitudinal reciprocation combined with a vertical reciprocation, the result of these two motions carrying the spreader from below the cloth-plate and a point behind the needle to a point above the cloth-plate with the point of the spreader projected beyond the path of reciprocation of the needle. As previously noted, and as shown in Figs. 2, 3 and 5, the trimming is done in advance of the stitching, and the trimmed edge, during the feed of the work, is carried forward until it strikes the face of the plate 66, when it is retarded and caused to descend in front of the machine. When it is desired to adjust the trimming-blades relatively to the line of stitching to be formed, the screws 31, are loosened and the screws 34, are removed. The bracket 29, is then shifted, which moves the lower blade 28, and by contact of the blade 28, with the depending finger of the trimming-blade 20, both the trimming elements are simultaneously adjusted; this being because the spring 22, normally holds the finger 25, yieldingly but firmly in contact with the blade 28. This is an important feature of my invention; as is also the means by which the lower blade is held in place in its bracket and by which it may be adjusted therein. When the adjustments referred to are to be made it may be necessary, according to the direction in which the adjustment is made, to move the eccentric strap relatively to its eccentric, and for this purpose the clearance, between the strap and the frame, at 43, is provided. Moreover, the arm 17, on the rock-shaft may have to be shifted, in which case the coupling between the strap 16, and arm 17, is removed, and the latter adjusted by loosening and tightening

the screw 65, and while the arm and strap are uncoupled, the latter can be properly adjusted on its eccentric.

From the above description of the construction and operation of my invention, its several important features and advantages can be readily seen; but, there are several features and combinations which I deem important and upon which I desire to lay stress. Aside from producing an effective machine for simultaneously sewing and trimming, or overedging and trimming, which is compact and light running, I have produced a trimming mechanism having several features of value and importance. The two blades are always in operative relation, by reason of the upper blade normally resting against the lower blade. The two blades can be simultaneously adjusted by merely moving the lower blade, because the upper blade is always bearing with yielding force upon the lower blade, and an adjustment of the latter in one direction forces the upper blade, while an adjustment in the opposite direction permits the spring 22, to act and force the upper blade to maintain its coöperative relation with the lower blade and automatically follow the latter into its new position or field of action. This is important in that adjustments can be made quickly by merely manipulating one blade, and when the one blade has been set the other is always found to be in proper coöperative relation and ready for effective work. Then, the means for clamping the lower blade in operative position is simple, effective and easily and quickly manipulated. Again, when assembling the parts and in making fine adjustments, it becomes necessary to be able to adjust all the parts of the mechanism and, hence, the removable coupling between the eccentric strap and arm 17, becomes important, as well as the means for adjusting the arms 17, and 19, on the rock-shaft. It is also important to be able to control the force with which the upper blade bears against the lower blade, both to compel the proper shearing action of the blades and the upper blade to follow the lower in its several positions of adjustment.

The cover-plate is particularly convenient as it completely covers the vitals of the machine, prevents lint from getting in the operative parts, shunts the trimmed edges, and, when removed, enables the operator to get at all the parts for adjustments and cleaning. The pivotal guard-plate permits threading the looper and spreader without removing the cover-plate.

It may be noted that while I have shown the deflector of the cover-plate secured to the spring and the latter in turn pivoted to the said plate, it will be obvious that I may extend the bottom of the deflector and pivot the same to the cover-plate and have the

spring bear upon the deflector in any suitable manner.

Having thus described my invention what I claim and desire to obtain by Letters Patent is:

1. A trimming mechanism for sewing machines comprising an upper reciprocating blade and a lower stationary blade; means for actuating the upper blade to cooperate with the stationary blade for trimming; and a lever pivoted beside the stationary blade so that it may be turned to overlap the latter, said lever having a cam-portion which bears upon the lower blade to firmly hold the same in position.

2. A trimming mechanism for sewing machines comprising a vibratory blade; a carrier for said blade having its journal at a right angle to, and laterally remote from, the plane of the path of vibration of said blade; and means for actuating said carrier, including a vibratory device having an open receiving portion normally presented upwardly, a part connected to the carrier and movable in a path enabling it to normally and naturally enter the said receiving portion, and means for coupling said receiving portion and said carrier-part, said means being accessibly presented to the operator so that he may, at will, separate the said parts of the actuating means, and throw the blade-carrier out of operation, thus enabling it to move its blade out of operative position.

3. A trimming mechanism for sewing machines comprising a pair of cooperating

blades; and a cam-lever pivoted adjacent one of the blades and bearing thereon for holding it in operative position, and said lever having a groove for the easement of the blade when the lever is shifted for adjustment of the blade.

4. A trimming mechanism for sewing machines comprising a vibratory blade; a carrier for said blade having its journal at a right angle to, and laterally remote from, the plane of the path of vibration of said blade; and means for actuating said blade, including a two-part actuating connection one of which parts is forked and has the free ends of its prongs presented upwardly for receiving the other part between them, and a device, accessibly presented to the operator, for coupling and uncoupling the said parts of the two-part connection, whereby the said blade may be thrown into and out of operation.

5. A sewing machine having combined therewith a trimming mechanism, and a cover-plate for shielding portions of the sewing and trimming mechanisms, said plate having a spring pivoted thereto, and a deflector connected to said spring.

In testimony whereof I have hereunto signed my name in the presence of two subscribing witnesses.

JOHN P. WEIS.

Witnesses:

CHAS. McCHAPMAN,
M. B. HOARE.