



- (51) International Patent Classification:  
F25D 23/00 (2006.01)
- (21) International Application Number:  
PCT/EP2016/058883
- (22) International Filing Date:  
21 April 2016 (21.04.2016)
- (25) Filing Language: English
- (26) Publication Language: English
- (30) Priority Data:  
A2015/06573 29 May 2015 (29.05.2015) TR
- (71) Applicant: **ARCELIK ANONIM SIRKETI** [TR/TR]; E5  
Ankara Asfalti Uzeri, Tuzla, 34950 Istanbul (TR).
- (72) Inventors: **YUSUFOGLU, Yusuf**; E5 Ankara Asfalti  
Uzeri, Tuzla, 34950 Istanbul (TR). **ONEY, Ceren**; E5  
Ankara Asfalti Uzeri, Tuzla, 34950 Istanbul (TR). **ER-  
DOGAN, Kadir**; E5 Ankara Asfalti Uzeri, Tuzla, 34950  
Istanbul (TR).

- (81) Designated States (unless otherwise indicated, for every kind of national protection available): AE, AG, AL, AM, AO, AT, AU, AZ, BA, BB, BG, BH, BN, BR, BW, BY, BZ, CA, CH, CL, CN, CO, CR, CU, CZ, DE, DK, DM, DO, DZ, EC, EE, EG, ES, FI, GB, GD, GE, GH, GM, GT, HN, HR, HU, ID, IL, IN, IR, IS, JP, KE, KG, KN, KP, KR, KZ, LA, LC, LK, LR, LS, LU, LY, MA, MD, ME, MG, MK, MN, MW, MX, MY, MZ, NA, NG, NI, NO, NZ, OM, PA, PE, PG, PH, PL, PT, QA, RO, RS, RU, RW, SA, SC, SD, SE, SG, SK, SL, SM, ST, SV, SY, TH, TJ, TM, TN, TR, TT, TZ, UA, UG, US, UZ, VC, VN, ZA, ZM, ZW.
- (84) Designated States (unless otherwise indicated, for every kind of regional protection available): ARIPO (BW, GH, GM, KE, LR, LS, MW, MZ, NA, RW, SD, SL, ST, SZ, TZ, UG, ZM, ZW), Eurasian (AM, AZ, BY, KG, KZ, RU, TJ, TM), European (AL, AT, BE, BG, CH, CY, CZ, DE, DK, EE, ES, FI, FR, GB, GR, HR, HU, IE, IS, IT, LT, LU, LV, MC, MK, MT, NL, NO, PL, PT, RO, RS, SE, SI, SK, SM, TR), OAPI (BF, BJ, CF, CG, CI, CM, GA, GN, GQ, GW, KM, ML, MR, NE, SN, TD, TG).

Published:  
— with international search report (Art. 21(3))

(54) Title: A POUCH SUITABLE FOR PLACING FILLER MATERIAL THEREIN AND THE PRODUCTION METHOD THEREOF

Figure 3

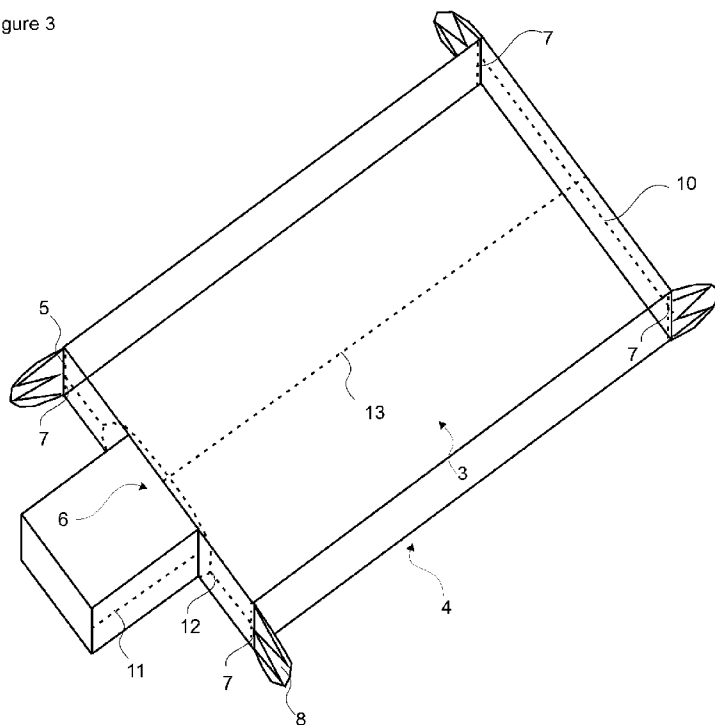

(57) Abstract: The present invention relates to a pouch (1) comprising a body (2) that is formed by folding on itself a quadrangular first layer (L1) produced from a non-rigid material and joining the abutting pair of sides and one of the two overlapping pair of sides, the body (2) having an upper surface (3), a lower surface (4), four corners (5) and an opening (6) enabling to fill the filler material therein.

**Description****A POUCH SUITABLE FOR PLACING FILLER MATERIAL THEREIN AND THE PRODUCTION METHOD THEREOF**

- [0001] The present invention relates to a pouch suitable to place filler material therein and the production method thereof.
- [0002] Vacuum insulation panels are used in various fields since they have better performance with respect to the conventional insulation materials and since they provide better thermal resistance by using the insulating feature of the vacuum. Vacuum insulation panels are produced by putting a porous filler material into a membrane (outer protective envelope) exclusively or together with getter material that retains gas and moisture according to the characteristic of the filler material, vacuuming and closing it by providing leak-proofing.
- [0003] In the state of the art, the use of two dimensional pouches produced from organic/cellulosic fibers or from various polymeric materials in paper or fabric form enabling the filler material to be filled therein in order to prevent material losses and dust formation of the powder filler material in the pressing and vacuuming steps before being shaped into a plate is known.
- [0004] The vacuum insulation material not being homogeneously distributed especially to the corners and sides of the two dimensional pouches, adversely affects the thermal insulation performance of the vacuum insulation panel.
- [0005] In the state of the art German Patent Application No. DE10248854, a two dimensional pouch is disclosed, wherein vacuum insulation material is filled, that is formed of inorganic and organic hybrid polymer layers, the dimensions of which are adjusted according to the size of the vacuum insulation panel and having only a sealing seam left open.
- [0006] The aim of the present invention is the realization of a pouch that enables the thermal insulation effectiveness of the vacuum insulation panel to be increased.
- [0007] The pouch realized in order to attain the aim of the present invention, explicated in the first claim and the respective claims thereof, comprises a body that is formed by folding on itself a quadrangular first layer produced

by knitting polymers like polypropylene, polyethylene, polyamide or organic/cellulosic fibers into cotton or synthetic fabric, preferably a resilient material and joining the abutting pair of sides and one of the two overlapping pair of sides, the body having an upper surface, a lower surface, four corners, and the pouch further comprising an opening enabling to fill the filler material therein and more than one corner stitch (preferably four) disposed at the corners, perpendicular to the lower surface and the upper surface, giving the body a rectangular prism shape such that there is a certain distance (for example between 1 to 3 cm) between the upper surface and the lower surface. The body, the production method of which is facilitated by folding and adhering the first material as a single piece on itself, wraps and protects the filler material filled therein.

- [0008] A pouch realized in order to attain the aim of the present invention is illustrated in the attached figures, where:
- [0009] Figure 1 – is the schematic view of the body, the filling orifice, and the support flaps that project out of the body relating to an embodiment of the present invention.
- [0010] Figure 2 – is the schematic view of the body, the filling orifice, and the support flaps that are folded over the body relating to an embodiment of the present invention.
- [0011] Figure 3 – is the schematic view of the pouch in rectangular prism shape relating to an embodiment of the present invention.
- [0012] The elements illustrated in the figures are numbered as follows:
1. Pouch
  2. Body
  3. Upper surface
  4. Lower surface
  5. Corner
  6. Opening
  7. Corner stitch
  8. Support flap
  9. Filling orifice

10. Transversal stitch
11. Filling orifice stitch
12. Joining stitch
13. Longitudinal stitch

[0013] (L1). First layer

[0014] (L2). Second layer

[0015] The pouch (1) of the present invention comprises a body (2) that is formed by folding on itself a quadrangular first layer (L1) produced from a non-rigid material and joining the abutting pair of sides and one of the two overlapping pair of sides, the body (2) having an upper surface (3), a lower surface (4), four corners (5) and an opening (6) enabling to fill the filler material therein, and the pouch (1) further comprising more than one corner stitch (7) perpendicular to the lower surface (4) and the upper surface (3), such that there is a certain distance between the upper surface (3) and the lower surface (4), giving the body (2) a rectangular prism shape. Ease of production is provided by producing the body (2) by folding the first layer (L1) over itself and without requiring to use a separate mould.

[0016] In an embodiment of the present invention, the pouch (1) comprises more than one support flap (8) that projects out from the corner stitches (7), the rigidity of which is increased by being subjected to thermal treatment so as to have approximately 45° angle between the sides of the body (2), the support flap (8) extending from the corners (5) inwards when the pouch (1) is turned inside out, enabling the body (2) to keep its rectangular prism shape by bearing against the upper surface (3) and the lower surface (4). By means of the support flaps (8), it is facilitated to give the pouch (1) a three dimensional shape.

[0017] In an embodiment of the present invention, the pouch (1) comprises a filling orifice (9) which facilitates the filling of the filler material into the body (2), that is connected with the sides of the body (2) surrounding the opening (6) and that is formed by a quadrangular second layer (L2) produced from non-rigid material, folded over itself and joining the abutting sides thereof. By means of the filling orifice (9), the filler material is filled

into the body (2) without being spilled outside.

- [0018] In an embodiment of the present invention, the pouch (1) comprises a longitudinal stitch (13) extending along the upper surface (3), the lower surface (4) or the side surface of the body (2), enabling the abutting sides when the first layer (L1) is folded to be joined.
- [0019] In an embodiment of the present invention, the pouch (1) comprises a transversal stitch (10) that is arranged opposite to the opening (6) in the body (2) and that enables the overlapping sides when the first layer (L1) is folded to be joined.
- [0020] In an embodiment of the present invention, the pouch (1) comprises a filling orifice stitch (11) that extends along the filling orifice (9) and that enables the sides that abut when the second layer (L2) is folded to be joined.
- [0021] In an embodiment of the present invention, the pouch (1) comprises a joining stitch (12) that enables the filling orifice (9) to be joined with the body (2).
- [0022] In an embodiment of the present invention, at least one of the corner stitch (7), the longitudinal stitch (13), the transversal stitch (10), the filling orifice stitch (11) or the joining stitch (12) is formed by plastic welding.
- [0023] In an embodiment of the present invention, at least one of the corner stitch (7), the longitudinal stitch (13), the transversal stitch (10), the filling orifice stitch (11) or the joining stitch (12) is formed by stitching thread.
- [0024] In an embodiment of the present invention, the production method of the pouch (1) comprises the following steps:
- Folding the first layer (L1) and joining the same with the longitudinal stitch (13) and the transversal stitch (10) for producing the body (2),
  - Giving the rectangular prism shape to the body (2) by means of the corner stitches (7),
  - Folding the second layer (L2) and joining the same with the filling orifice stitch (11) for producing the filling orifice (9),
  - Joining the filling orifice (9) to the body (2) by means of the joining stitch (12),
  - Turning the pouch (1) inside out and enabling the support flaps (8) to

extend inwards from the corners (5) of the body (2).

[0025] In this embodiment, during the production of the body (2), after adhering the sides of the folded first layer (L1), only one of the open sides is joined by thermal adhering such that the formerly adhered part remains in the middle or on the side. The side of the body (2) left open is turned inside out such that the inner part of the side faces outside. The produced filling orifice (9) is placed to extend inside the body (2) from the upside turned side and the overlapping filling orifice (9) and the sides of the body (2) are adhered by heat sealing by placing a fireproof – nonstick material at the inner side of the filling orifice (9). The filling orifice (9) must stay open so that the filler material can be filled into the body (2). After the heat sealing process is completed, the fireproof – nonstick material placed at the inner side of the filling orifice (9) is taken out. The pouch (1) that takes the form of a two dimensional bag and subjected to 90° angle heat sealing process from the corners (5) is turned inside out for making the pouch (1) three dimensional. By means of the turning inside out operation, the pouch (1) gains depth before filling the filler material into the pouch (1). By means of the pouch (1) having gained depth, the filler material is easily filled into the pouch (1) and the material density difference especially between the corners (5) and the middle parts is decreased.

[0026] By means of the present invention, in particular by means of the pouch (1) having three dimensional shape, the filler material is filled into the pouch (1) homogeneously. The thermal insulation performance of the vacuum insulation panel is improved by filling the filler material of the same density to the sides, the corners (5) and the middle parts of the pouch (1). Furthermore, by means of the filling orifice (9), the filler material is filled into the body (2) more easily. Ease of production is provided by means of producing the pouch (1) by folding a single material without requiring to use a separate mould.

## Claims

1. A pouch (1) comprising a body (2) that is formed by folding on itself a quadrangular first layer (L1) produced from a non-rigid material and joining the abutting pair of sides and one of the two overlapping pair of sides, the body (2) having an upper surface (3), a lower surface (4), four corners (5) and an opening (6) enabling to fill the filler material therein, **characterized by** more than one corner stitch (7) perpendicular to the lower surface (4) and the upper surface (3), such that there is a certain distance between the upper surface (3) and the lower surface (4), giving the body (2) a rectangular prism shape.
2. A pouch (1) as in Claim 1, **characterized by** more than one support flap (8) that projects out from the corner stitches (7), the rigidity of which is increased by being subjected to thermal treatment and the support flap (8) extending from the corners (5) inwards when the pouch (1) is turned inside out, enabling the body (2) to keep its rectangular prism shape by bearing against the upper surface (3) and the lower surface (4).
3. A pouch (1) as in Claim 1 or 2, **characterized by** a filling orifice (9) that is connected with the sides of the body (2) surrounding the opening (6) and that is formed by a quadrangular second layer (L2) produced from non-rigid material, folded over itself and joining the abutting sides thereof.
4. A pouch (1) as in any one of the above claims, **characterized by** a longitudinal stitch (13) extending along the upper surface (3), the lower surface (4) or the side surface of the body (2), enabling the abutting sides when the first layer (L1) is folded to be joined.
5. A pouch (1) as in any one of the above claims, **characterized by** a transversal stitch (10) that is arranged opposite to the opening (6) in the body (2) and that enables the overlapping sides when the first layer (L1) is folded to be joined.
6. A pouch (1) as in any one of the Claim 3 to Claim 5, **characterized by** a filling orifice stitch (11) that extends along the filling orifice (9) and that enables the sides that abut when the second layer (L2) is folded to be joined.
7. A pouch (1) as in any one of the Claim 3 to Claim 6, **characterized by** a joining stitch (12) that enables the filling orifice (9) to be joined with the body (2).
8. A pouch (1) as in Claim 7, **characterized by** at least one of the corner stitch (7), the longitudinal stitch (13), the transversal stitch (10), the filling orifice stitch

- (11) or the joining stitch (12) that is formed by plastic welding.
9. A pouch (1) as in Claim 7, **characterized by** at least one of the corner stitch (7), the longitudinal stitch (13), the transversal stitch (10), the filling orifice stitch (11) or the joining stitch (12) that is formed by stitching thread.
10. A refrigerator **characterized by** a pouch (1) used in production of vacuum insulation panel as in any one of the above claims.
11. A production method for a pouch (1) as in Claim 1, comprising the steps of :
- Folding the first layer (L1) and joining the same with the longitudinal stitch (13) and the transversal stitch (10) for producing the body (2),
  - Giving the rectangular prism shape to the body (2) by means of the corner stitches (7),
  - Folding the second layer (L2) and joining the same with the filling orifice stitch (11) and the body (2) for producing the filling orifice (9),
  - Joining the filling orifice (9) to the body (2) by means of the joining stitch (12),
  - Turning the pouch (1) inside out and enabling the support flaps (8) to extend inwards from the corners (5) of the body (2).

Figure 1

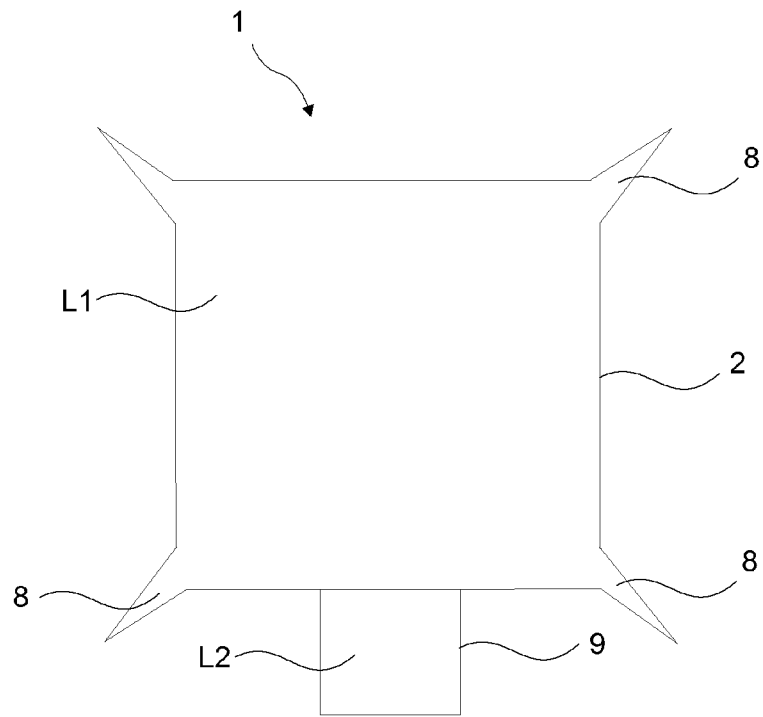

Figure 2

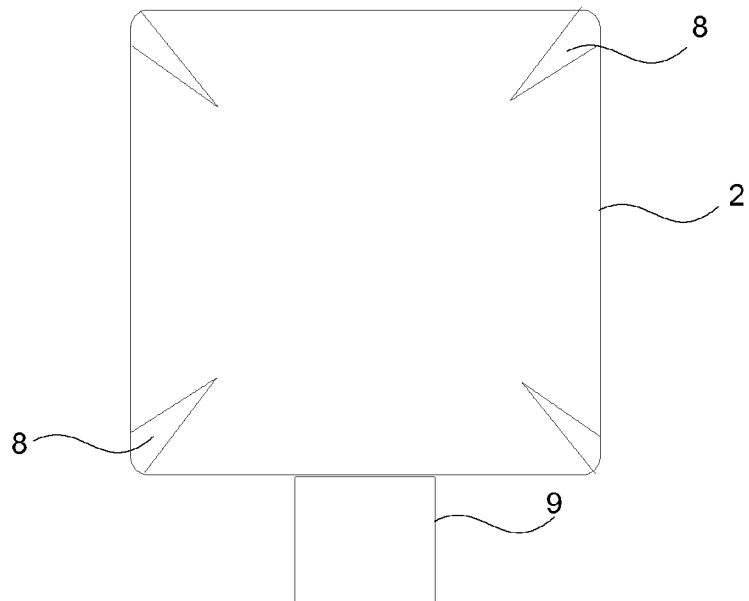
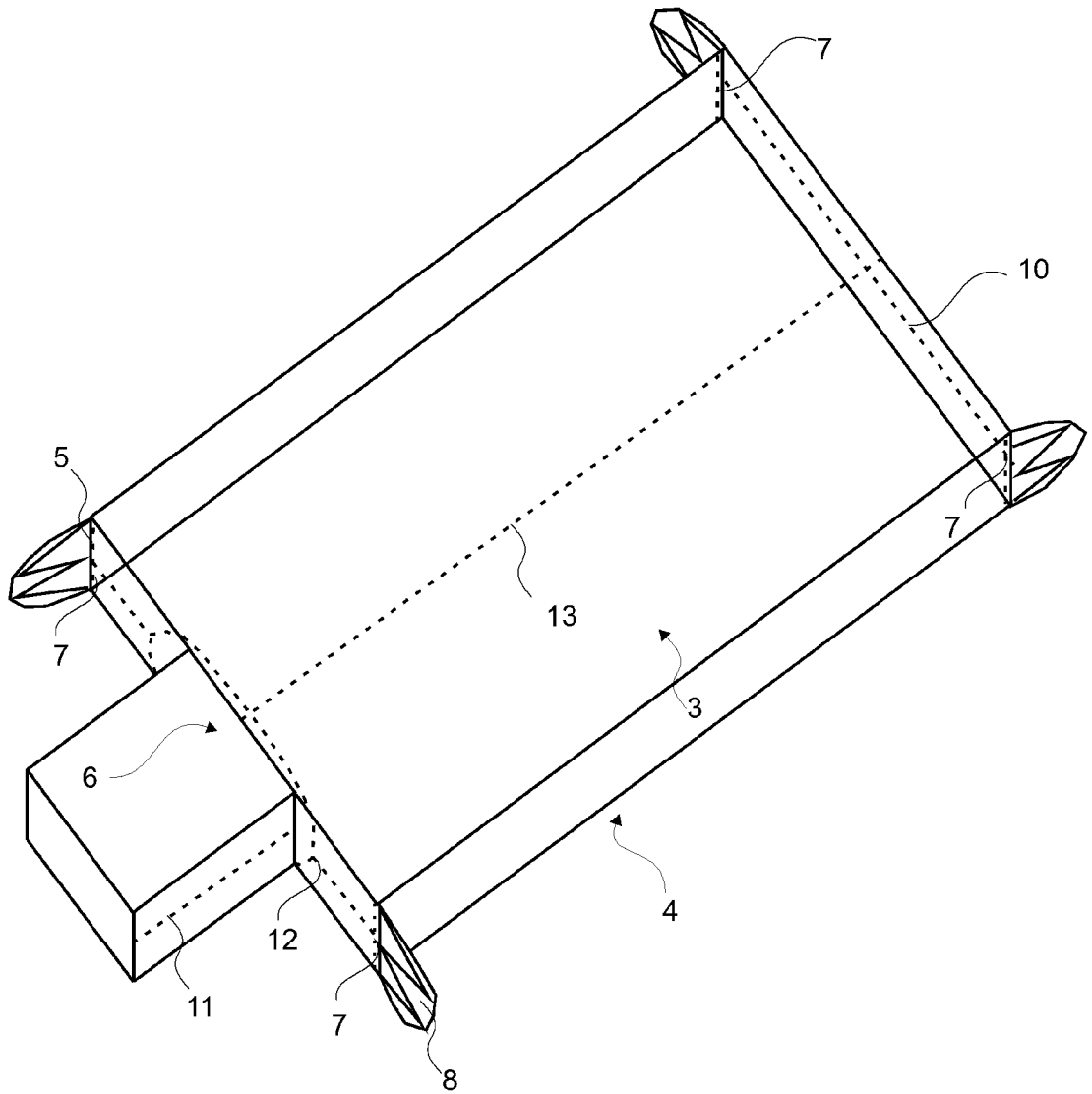

Figure 3



INTERNATIONAL SEARCH REPORT

International application No  
PCT/EP2016/058883

A. CLASSIFICATION OF SUBJECT MATTER  
INV. F25D23/00  
ADD.  
According to International Patent Classification (IPC) or to both national classification and IPC

B. FIELDS SEARCHED  
Minimum documentation searched (classification system followed by classification symbols)  
F25D B65D A21C F16L

Documentation searched other than minimum documentation to the extent that such documents are included in the fields searched

Electronic data base consulted during the international search (name of data base and, where practicable, search terms used)  
EPO-Internal, WPI Data

C. DOCUMENTS CONSIDERED TO BE RELEVANT

Category*	Citation of document, with indication, where appropriate, of the relevant passages	Relevant to claim No.
X Y	US 2011/069911 A1 (ACKERMAN BRYAN L [US] ET AL) 24 March 2011 (2011-03-24) figures 1,3 -----	1-3,6,8, 9 7
X	US 3 008 835 A (MADDING ROBERT T) 14 November 1961 (1961-11-14) figure 3 -----	1,4
X	WO 2009/016572 A1 (IAMS COMPANY [US]; SCHUMACHER LAWRENCE ANDREW [US]; KERR GEORGE SCOTT) 5 February 2009 (2009-02-05) figure 1 -----	1,5
X	WO 2006/009146 A1 (KURASHIKI BOSEKI KK [JP]; TAKASHIMA HIROYUKI [JP]; YAMASHITA KOUJI [JP]) 26 January 2006 (2006-01-26) abstract; figure 7 ----- -/--	1,10

Further documents are listed in the continuation of Box C.  See patent family annex.

\* Special categories of cited documents :

"A" document defining the general state of the art which is not considered to be of particular relevance	"T" later document published after the international filing date or priority date and not in conflict with the application but cited to understand the principle or theory underlying the invention
"E" earlier application or patent but published on or after the international filing date	"X" document of particular relevance; the claimed invention cannot be considered novel or cannot be considered to involve an inventive step when the document is taken alone
"L" document which may throw doubts on priority claim(s) or which is cited to establish the publication date of another citation or other special reason (as specified)	"Y" document of particular relevance; the claimed invention cannot be considered to involve an inventive step when the document is combined with one or more other such documents, such combination being obvious to a person skilled in the art
"O" document referring to an oral disclosure, use, exhibition or other means	"&" document member of the same patent family
"P" document published prior to the international filing date but later than the priority date claimed	

Date of the actual completion of the international search <b>24 June 2016</b>	Date of mailing of the international search report <b>07/07/2016</b>
----------------------------------------------------------------------------------	-------------------------------------------------------------------------

Name and mailing address of the ISA/ European Patent Office, P.B. 5818 Patentlaan 2 NL - 2280 HV Rijswijk Tel. (+31-70) 340-2040, Fax: (+31-70) 340-3016	Authorized officer <b>Kuljis, Bruno</b>
----------------------------------------------------------------------------------------------------------------------------------------------------------------------	--------------------------------------------

## INTERNATIONAL SEARCH REPORT

International application No  
PCT/EP2016/058883

C(Continuation). DOCUMENTS CONSIDERED TO BE RELEVANT		
Category*	Citation of document, with indication, where appropriate, of the relevant passages	Relevant to claim No.
X	Anonymous: "Zippered pouch (part two-adding a bottom)",  21 March 2012 (2012-03-21), XP055283273, Retrieved from the Internet: URL: <a href="http://ihavetosay.typepad.com/randi/2012/03/sew-along-with-me-zippered-pouch-part-two.html">http://ihavetosay.typepad.com/randi/2012/03/sew-along-with-me-zippered-pouch-part-two.html</a> [retrieved on 2016-06-23]	1,6,8,9, 11
Y	the whole document -----	7
A	GB 2 336 565 A (MICROPORE INTERNATIONAL LTD [GB]) 27 October 1999 (1999-10-27) figures 7,8 -----	1,10,11

# INTERNATIONAL SEARCH REPORT

Information on patent family members

International application No PCT/EP2016/058883
---------------------------------------------------

Patent document cited in search report	Publication date	Publication date	Patent family member(s)	Publication date
US 2011069911	A1	24-03-2011	CA 2715210 A1	24-03-2011
			US 2011069911 A1	24-03-2011
			US 2013322788 A1	05-12-2013
-----				
US 3008835	A	14-11-1961	NONE	
-----				
WO 2009016572	A1	05-02-2009	AR 067776 A1	21-10-2009
			AU 2008281407 A1	05-02-2009
			BR PI0815002 A2	03-03-2015
			CA 2693285 A1	05-02-2009
			CN 101765548 A	30-06-2010
			EP 2170718 A1	07-04-2010
			JP 5335788 B2	06-11-2013
			JP 2010535140 A	18-11-2010
			RU 2010101241 A	10-09-2011
			US 2009136163 A1	28-05-2009
			US 2013004627 A1	03-01-2013
			WO 2009016572 A1	05-02-2009
-----				
WO 2006009146	A1	26-01-2006	KR 20090017645 A	18-02-2009
			US 2008095970 A1	24-04-2008
			WO 2006009146 A1	26-01-2006
-----				
GB 2336565	A	27-10-1999	NONE	
-----				