

B. MORTON.

Axle Washer.

No. 111,964.

Patented Feb. 21, 1871.

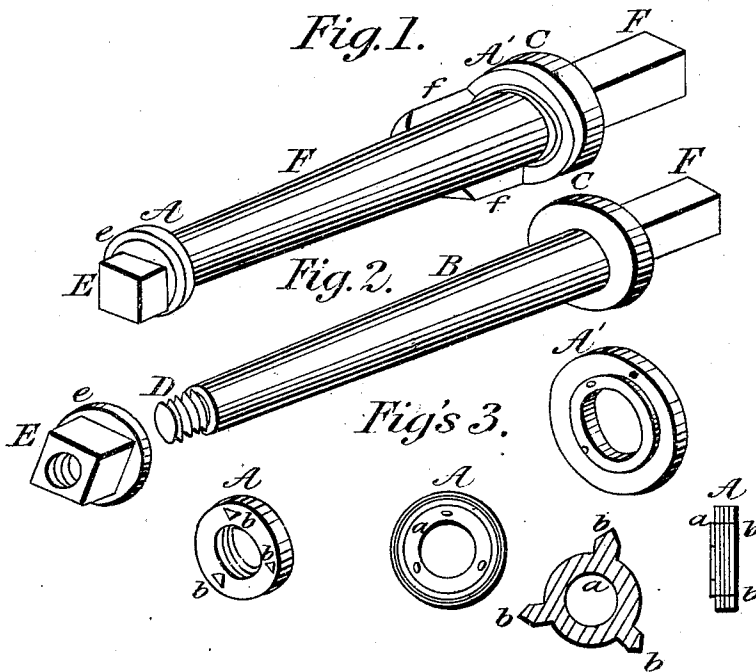

Witnesses:

Wm B. Wiley
Georg Stauffer

Inventor:

Benjamin Morton

United States Patent Office.

BENJAMIN MORTON, OF FERTILITY, PENNSYLVANIA.

Letters Patent No. 111,964, dated February 21, 1871.

IMPROVEMENT IN ANTI-RATTLING WASHERS.

The Schedule referred to in these Letters Patent and making part of the same.

I, BENJAMIN MORTON, of Fertility, in the county of Lancaster and State of Pennsylvania, have invented certain Improvements to Prevent the Rattling of the Wheels of Vehicles, of which the following is a specification.

The nature of my invention consists in the means employed to prevent the noise made by the clatter of the metallic boxes against the shoulders of the axle and the nut that secure the hub to the spindle, so as not to increase the friction, by means of a compound washer on each end of the spindle or boxes within the hub.

The drawing shows the combined washers and their application.

Figure 1 represents the combined washers A *a* in place.

F, the box or thimble-skein inserted within the hub of wheels on vehicles.

Figure 2 shows the spindle with its shoulder and part of the axle.

Figure 3, the combined washers in perspective, side, and front view.

My invention, however useful in its application, is so simple that a statement is sufficient to enable any one to make and apply the same.

The combined washers A *a* A' *a'* are made by riveting or inserting the projecting end *b* of a metallic ring, *a* *a'*, of brass, or the like, upon or through a larger ring, A A', made of leather, or its equivalent elastic material, which will produce traction, so as to hold the combined washer in place; the heads of the rivets when used being flush with the face or countersunk on both sides, so as to present an even surface.

One of the combined washers, with the traction or elastic face A', is slipped over the spindle up to the shoulder C on the end of the spindle. The hub or box F is then slid over the spindle against the metallic face *a'* of the washer.

A similar washer, A, (somewhat smaller,) is then inserted over the front end of the spindle over the screw, with the metallic face *a* inward, against the outer edge of the thimble or box F, and held by the flange *e* on the nut E when screwed up.

While the metallic smooth face of the washers *a* cause but little friction, and being firmly united with the elastic or traction washer A, the combined washers will remain stationary, and prevent wearing, so as to enlarge the annular opening, and even when the metallic faces *a* *a'* are worn, the concussion of the parts will be muffled and the noise prevented by the elastic portion of the washers.

I am aware that I cannot claim a metallic washer, or a leather or gum washer, for such are common. I therefore do not claim the combined washer apart from its application in the manner stated, which I believe to be new, and on trial proved to be fully adapted to accomplish the object in view.

What I claim as my invention is—

The combined washer A *a*, when made and applied to the spindles of vehicles, in the manner and for the purpose specified.

BENJAMIN MORTON.

Witnesses:

WM. B. WILEY,
JACOB STAUFFER.