

S. C. STALEY.  
 GAGE COCK.  
 APPLICATION FILED JAN. 3, 1913.

1,067,945.

Patented July 22, 1913.

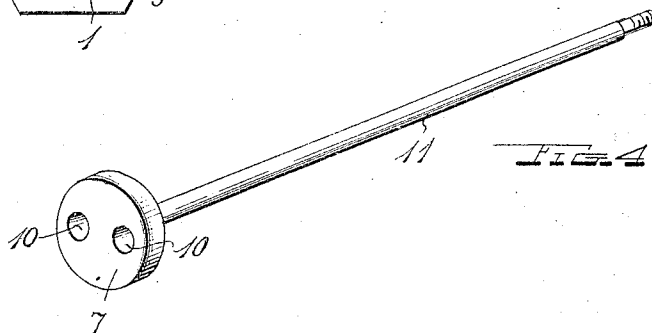
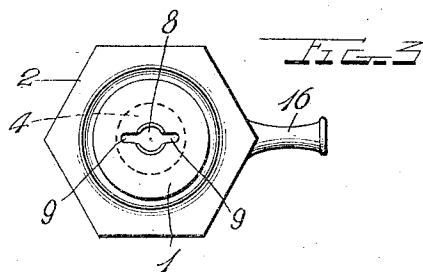
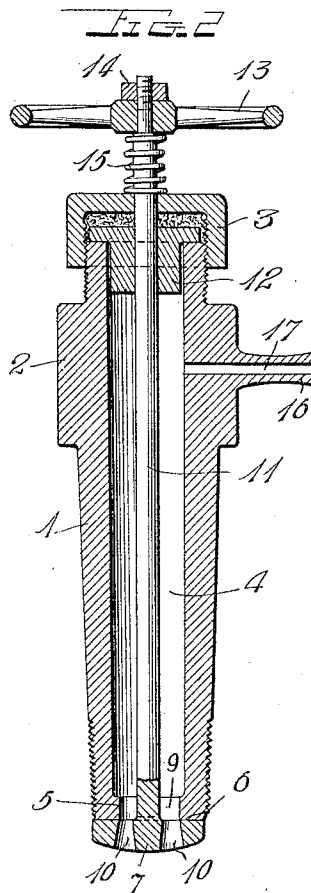
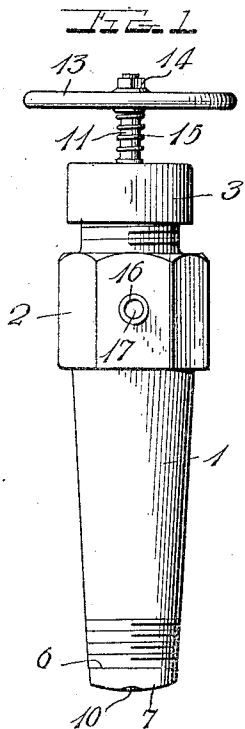

Witnesses  
*A. Van Loek*  
*C. E. Hunt*

Inventor  
*S. C. Staley*  
 By *A. B. Wilson*  
 Attorney

# UNITED STATES PATENT OFFICE.

SYLVESTER C. STALEY, OF CENTRALIA, ILLINOIS.

## GAGE-COCK.

1,067,945.

Specification of Letters Patent.

Patented July 22, 1913.

Application filed January 3, 1913. Serial No. 740,064.

*To all whom it may concern:*

Be it known that I, SYLVESTER C. STALEY, a citizen of the United States, residing at Centralia, in the county of Marion and State of Illinois, have invented certain new and useful Improvements in Gage-Cocks; and I do declare the following to be a full, clear, and exact description of the invention, such as will enable others skilled in the art to which it appertains to make and use the same.

This invention relates to improvements in gage cocks for boilers.

One object of the invention is to provide a gage cock the construction of which is such that it will not become clogged when muddy water is used in the boiler and which is provided with an improved construction and arrangement of valve which is at all times held in close engagement with its seat thereby preventing grit or other foreign matter from getting between the valve and the seat.

With this and other objects in view, the invention consists of certain novel features of construction, and the combination and arrangement of parts as will be more fully described and claimed.

In the accompanying drawings: Figure 1 is a front view of my improved gage cock; Fig. 2 is a central longitudinal section thereof; Fig. 3 is an inner end view of the casing or body of the gage cock with the valve removed, and showing more plainly the construction and arrangement of the discharge ports in the inner end of the casing; Fig. 4 is a detail perspective view of the valve and its operating stem removed from the casing or body of the gage cock.

My improved gage cock comprises a body portion 1 which tapers from its outer toward its inner end and which is exteriorly threaded for a suitable distance at its inner end whereby said end of the cock may be screwed into a threaded opening in the boiler. The body 1 is provided near its outer end with a flat sided enlargement 2 with which is adapted to be engaged a wrench whereby the device is readily screwed into a boiler. The outer end of the body 1 is also exteriorly threaded to receive a stuffing box 3. The bore 4 extends from the outer end of the body to a point near the inner end thereof which is closed only by a comparatively thin wall 5, the outer surface of which forms the seat 6 of the valve 7

hereinafter described. In the inner end or wall of the body 1 is formed a centrally disposed passage 8 and oppositely disposed notches 9 which communicate at their inner ends with the passage and form ports in the inner end of the gage cock. Resting on the valve seat 6 is the valve 7 which is in the form of a disk having therein oppositely disposed water inlet ports or passages 10 which preferably taper from their outer toward their inner ends as shown. The valve 7 is provided with a stem 11 which projects through the passage 8 in the end 5 of the gage cock and extends through the bore 4 thereof and through the stuffing box 3 as shown. The valve stem 11 also projects through and is centered at its outer end in the bore 4 by a bushing 12 arranged in the outer end of the bore and having an annular flange which engages the outer end of the body 1 within the stuffing box 3 as shown. The outer end of the valve stem 11 is reduced and threaded and carries a handle or wheel 13 which is secured to the stem by a nut 14 as shown. Between the hub of the valve operating wheel 13 and the outer end of the stuffing box 3 is arranged a coiled spring 15 the pressure of which holds the valve 7 in close engagement with its seat to prevent any possible chance of grit or foreign matter getting between the valve and its seat and wearing these parts.

The gage cock is provided on one side near its outer end with a discharge nipple 16 which is preferably formed integral with one of the flat sides of the enlargement 2 of the body 1 and which has a bore 17 extending directly through the same and through the side of the casing or body of the cock and communicating at its inner end with the bore 4.

It will be noted that the bore 4 in the body of the cock is of considerably greater diameter than the diameter of the valve stem 11 thus forming a large free passage for the water passing through the gage cock from the boiler. It will also be noted that the ports 9 by reason of the thin wall forming the inner end of the cock are quite short so that the water entering the cock has but a short distance to pass before entering the enlarged bore of the gage cock thus reducing to a minimum any possibility of the valve becoming clogged when muddy water is used.

In opening and closing the cock it is

simply necessary to grasp the wheel 13 and to turn the valve stem 11 and valve 7 thereon in either direction for bringing the ports 10 in the valve into and out of alinement with the ports 9 in the inner end of the gage cock.

From the foregoing description taken in connection with the accompanying drawings the construction and operation of the invention will be readily understood without requiring a more extended explanation.

Various changes in the form, proportion and the minor details of construction may be resorted to without departing from the principle or sacrificing any of the advantages of the invention as claimed.

Having thus described my invention, what I claim is:

In a gage cock, a tubular body externally screw threaded at its inner and outer ends, a laterally extended outlet nozzle between said ends, a stuffing box secured to said outer end,

a comparatively thin integral wall closing said inner end and having a central opening and diametrically disposed slots or notches radiating from said central opening and forming ports, a disk-shaped valve, a stem integral therewith and adapted to pass through said central opening, tubular body and stuffing box, said disk valve having ports adapted to register with said slots or notches, a hand wheel upon the outer end of said stem, and a coiled expansion spring between said wheel and stuffing box whereby the valve disk is held in close engagement with the outside of said wall, substantially as described.

In testimony whereof I have hereunto set my hand in presence of two subscribing witnesses.

SYLVESTER C. STALEY.

Witnesses:

B. M. ENGLISH,

G. E. EIS.