

(19) World Intellectual Property Organization
International Bureau



(43) International Publication Date
19 April 2001 (19.04.2001)

PCT

(10) International Publication Number
WO 01/27681 A1

- (51) International Patent Classification⁷: G02B 26/02, 6/26 (74) Agent: BARTH, Daniel; Hewlett-Packard GmbH, Europäische Patent- und Lizenzabt., Herrenberger Strasse 130, D-71034 Böblingen (DE).
- (21) International Application Number: PCT/EP99/07553
- (22) International Filing Date: 8 October 1999 (08.10.1999) (81) Designated States (national): JP, US.
- (25) Filing Language: English (84) Designated States (regional): European patent (AT, BE, CH, CY, DE, DK, ES, FI, FR, GB, GR, IE, IT, LU, MC, NL, PT, SE).
- (26) Publication Language: English
- (71) Applicant (for all designated States except US): HEWLETT-PACKARD COMPANY [US/US]; 3000 Hanover Street, Palo Alto, CA 94304-1112 (US). Published:
— With international search report.
— With amended claims.
- (72) Inventor; and
(75) Inventor/Applicant (for US only): SCHMIDT, Siegmund [DE/DE]; Breitestrasse 28-1, D-72218 Wildberg (DE). For two-letter codes and other abbreviations, refer to the "Guidance Notes on Codes and Abbreviations" appearing at the beginning of each regular issue of the PCT Gazette.

(54) Title: OPTICAL IMAGING SYSTEM

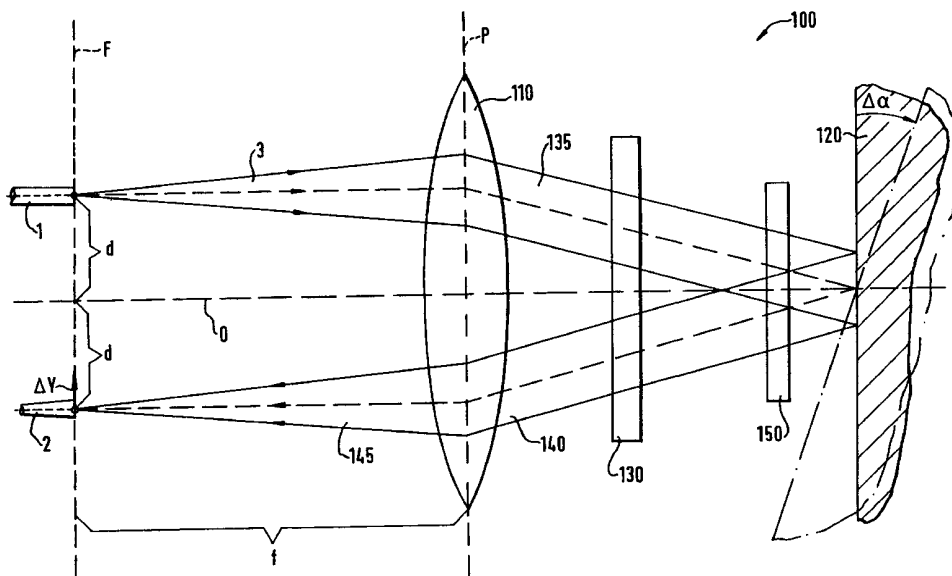

(57) Abstract: Disclosed is an optical system for imaging an input beam (3) from an input (1) to an output beam (145) at an output (2). The system comprises a lens (110) adapted for receiving the input beam from the input, and a reflecting device (120) adapted for reflecting the input beam from the lens back to the lens. The lens is adapted for converging the beam reflected by the reflecting device to the output. The input and the output are both located substantially in the focal plane (F) of the lens and off axis, with respect to the optical axis of the lens, on opposing sides from the optical axis (O) of the lens. The reflecting device is located on a side opposite, with respect to the principal plane (P) of the lens, to the side of the input and the output.



WO 01/27681 A1

OPTICAL IMAGING SYSTEM

BACKGROUND OF THE INVENTION

The present invention relates to an optical imaging system for optically mapping an object at an input to an object at an output.

- 5 Optical imaging systems are widely known in the art and can be applied for mapping an input image to an output image substantially with or without modifying the characteristics of the input image. A typical application wherein the characteristics of the input image is intended to be modified by the optical imaging system is in optical attenuator.
- 10 Optical attenuators are known e.g. from DE-A-3613688 or GB-A-2074339. EP-A-557542 discloses an optical attenuator as shown in Fig. 1. The attenuator is inserted between two optical fibers 1 and 2. A cone of light 3 leaving the fiber 1 is converted by a lens 4 to a beam of parallel light 5, which impinges on an attenuator disc 6. The attenuator disc 6 comprises two parts 25 and 28 glued together such
- 15 that they form a disc having rectangular cross section. After transmission through the disc 6, the attenuated light beam 7 impinges on a corner cube 8 reflecting the incident light into the same direction where it came from, but with a parallel offset. Thus, the beam reflected from the corner cube 8 is again transmitted through the disc 6, but at a slide different position than at the first transmission.
- 20 The purpose of transmitting the beam twice through the attenuator disc 6 is to compensate beam deviations caused by refractive index differences and oblique light incidence. After the second transmission through the disc 6, the beam 9 impinges on a prism 10 which reflects the beam twice by 90 degrees such that the outgoing beam 11 has a parallel offset relative to the beam 9 leaving the attenuator
- 25 disc 6. The outgoing beam 11 is then focused by a lens 12 into the fiber 2. The disc 6 is rotatable around an axis 13 by means of a motor 14 in response to control signals from a control circuitry 20. The adjustment of different attenuation factors is achieved by adjusting different angular orientations of the disc 6.

The attenuator disc 6 comprises one part 28 which is made of a light absorbing material and one part 25 which is substantially transparent for the light impinging on it. Those parts are wedge-shaped and fixed together such that the resulting disc 6 has a rectangular cross section. The thickness of the wedges, in combination,
5 remains constant in a direction perpendicular to the plane of the paper in Fig. 1. The beams 5 and 9 impinging on the light-absorbing wedge from the left or from the right (after reflection by the corner cube 8) traverse the same distance within the light-absorbing wedge. Since the thickness of the absorbing part of the disc 6 which the beam 5 passes depends on the angular orientation of disc 6, the attenuation of
10 the beam 5 can be continuously varied by rotating the disc 6 around the axis 13. The motor 14 might be furnished with a position encoder indicating the angular position of the attenuator disc 6.

SUMMARY OF THE INVENTION

It is an object of the present invention to provide an improved optical attenuator in
15 particular with respect to costs. The object is solved by the independent claims. Preferred embodiments are shown by the dependent claims.

The invention provides an improved optical imaging or mapping system for mapping an object at an input source to an object at an output. The optical mapping system of the present invention comprises a source adapted for emitting a diverging optical
20 beam to a lens, a reflecting device (such as a mirror) adapted for reflecting a parallel beam from the lens back to the lens, and an output adapted for receiving a converging beam from the lens. The source and the output are both located substantially in the focal plane of the lens and off axis, with respect to the optical axis of the lens, on opposing sides from the optical axis of the lens. The reflecting
25 device is located on opposite side of the source and the output with respect to the principal plane of the lens and arranged so that a beam from the source will be mapped to the output.

Because of the off axis location of the source and the beam with highest intensity

from the source not being directed through the center of the lens, the lens collimates the diverging light beam from the source to a parallel beam skew with respect to the optical axis. The reflecting device reflects this skew but parallel beam back to the lens. In this reverse direction, the optical radiation is focused to the
5 output. The position (i.e. distance away from the lens and angle with the principal plane of the lens) of the reflecting device is preferably chosen for achieving a low insertion loss for coupling optical radiation from the source to the output.

It will be appreciated that while the optical mapping system of Fig. 1 comprises two lenses (4 and 12), the optical mapping system of the present invention is designed
10 to require only one lens, and the optical beam travels twice through the lens system. Thus, the optical mapping system of the present invention requires less components and adjustment effort than the optical mapping system applied for the attenuator of Fig. 1, and is therefore less expensive and easier to produce and adjust.

15 In a preferred embodiment, the plane of the reflecting device is substantially parallel with the principal plane of the lens. However, it is to be understood that tilting (i.e. providing an angle between the plane of the reflecting device and the principal plane of the lens) the reflecting device can be used/required for compensating a difference in off axis location between the source and the output, and vice versa.

20 In another embodiment, the plane of the reflecting device substantially crosses the optical axis of the lens at the cross point of the optical axis of the lens with beam of highest intensity from the source after passing the lens. Thus, a low insertion loss can be achieved.

Another degree of freedom for the design of the mapping system is the angle of
25 radiation (preferably of the beam with highest intensity) from the source. Increasing the angle provided with the optical axis of the lens requires that the reflecting device has to be positioned farther away from the lens. Thus, the longitudinal dimension of the system can be adjusted as might be required e.g. for inserting components

in the beam.

It is to be understood that the optically simplest arrangement for a mapping according to the invention is in case that:

- 5 • the source and the output are both located off axis in the focal plane of the lens, whereby the beam with highest intensity from the source is directed to the lens but not through the center of the lens;
- 10 • the plane of the reflecting device is substantially parallel with the principal plane of the lens and might only be slightly tilted in order to compensate a (slight) deviation in the distances of the source and the output from the optical axis of the lens; and
- the plane of the reflecting device substantially crosses the optical axis of the lens at the cross point of the optical axis of the lens with beam of highest intensity from the source after passing the lens.

15 It is clear, however, that deviations from this 'easiest' design can increase the optical complexity of the system, but might be desired for specific applications.

20 In a preferred embodiment, fiber ends respectively represent the source and the output. The input and output fiber ends, emitting light towards the optical attenuator or receiving light therefrom, are preferably both located in the focal plane of the lens. The position of the input fiber end and the output fiber end are both off axis, each preferably situated with the same distance away (offset) from the axis. The input and output fibers are preferably located very tight together and preferably glued in a holding device. By providing the fiber ends angled, the angle of radiation of the center beam (with highest intensity) and thus the distance between the lens and the reflecting device can be adjusted.

25 Within the optical mapping system of the present invention, different components (such as any kind of attenuating filter as known in the art such as the attenuating filters as disclosed in EP-A-557542) can be applied for modifying the characteristics

of the output beam with respect to the characteristics of the input beam of the system. The component(s) is/are preferably inserted between the lens and the reflecting device, whereby the component(s) can be arranged so that the beam travels once or twice through the component(s), or, in other words, that either only
5 the parallel beam to or from the reflecting device, or both pass the respective component(s).

The input and output fiber ends can be straight or angled, and might be provided e.g. by using polishing or cleaving techniques. Angled fiber ends can be applied for achieving low back reflections (high return loss), as disclosed e.g. in the co-pending
10 European Patent Application 99109469.9 by the same applicant. The teaching of that document with respect to the provision of termination surfaces will be incorporated herein by reference.

Between the lens and the reflecting device, an optional polarization rotator (as disclosed e.g. by Donald K. Wilson in "Optical isolators cut feedback in visible and near-IR lasers", Laser Focus/Electro-Optics, Dec. 1988, pp. 103 ff.) might be
15 located to reduce the polarization dependent attenuation e.g. resulting from an inserted component such as a filter. Preferably, the polarization rotator is an optical Faraday rotator with 45 degrees polarization rotation. In this case, the optical radiation forward beam and reverse beam go through the Faraday rotator and the
20 total polarization rotation is $2 \times 45^\circ = 90^\circ$. Because of the resulting polarization dependent loss $PDL = 0$, the optical polarization axis of any elliptical (or linear) state of polarization of the reverse beam is rotated 90 degrees with respect to the optical polarization axis of any elliptical (or linear) state of polarization of the forward beam. Due to the passing twice through the optical filter with a polarization rotation of 90
25 degree between the forward and the reverse beam, the polarization dependent loss of the optical filter is averaged out. The result is a polarization independent attenuation of the complete optical system according to the invention.

The reflecting device is preferably designed to provide a maximum of reflectivity and a low insertion loss. For wavelengths in the near infrared spectrum, e.g. about

1550nm, the reflecting device is preferably provided as a gold-coated mirror. Accordingly, for other wavelengths, a mirror with maximum reflectance will have to be chosen.

5 The optical system according to the invention can thus be designed to provide no or only reduced polarization dependent attenuation, in particular with respect to the embodiment of Fig. 1. Furthermore the inventive optical system is less costly than e.g. the system of Fig. 1, since less material is required (e.g. only one lens instead of two). Additionally, the adjustment effort can be significantly reduced when e.g. the input and output fibers are adjusted together. Moreover, due to the double-pass
10 design a compact size of the complete optical system can be achieved.

BRIEF DESCRIPTION OF THE DRAWINGS

Other objects and many of the attendant advantages of the present invention will be readily appreciated and become better understood by reference to the following detailed description when considering in connection with the accompanied
15 drawings. Features that are substantially or functionally equal or similar will be referred to with the same reference sign(s).

Fig. 1 shows an optical attenuator as known in the art, and

Figs. 2 and 3 show embodiments of an optical attenuator 100 according to the invention.

20 DETAILED DESCRIPTION OF THE INVENTION

Fig. 2 shows a first embodiment of an optical attenuator 100 according to the invention comprising a lens 110, an optical mirror 120 and an optical attenuating filter 130 in-between. P denotes the principle plane, F the focal plane, and O the optical axis of the lens 110. The input fiber 1 and the output fiber 2 are both located
25 off axis, preferably with the same distance (offset) d away from the optical axis O. Furthermore, the ends of the input fiber 1 and the output fiber 2 are preferably both located substantially in the focal plane F.

In case that the ends of the input fiber 1 and the output fiber 2 are not off axis with the same distance from the axis, the mirror 120 has to be tilted by an angle $\Delta\alpha$ (as indicated in Fig. 2) with respect to the principal plane P. The fiber end 2 will be displaced by an amount Δy dependent on the angle $\Delta\alpha$ and the focal length f:

5
$$\Delta y \approx f \cdot \tan(2 \cdot \Delta\alpha).$$

The cone of light 3 leaving the fiber 1 is collimated by the lens 110 to a parallel forward beam 135. Due to the off axis location of the input fiber 1, the forward beam 135 is skew with respect to the optical axis O. The forward beam 135 is reflected at the optical mirror 120, which is provided substantially parallel to the principle
10 plane P of the lens 110, into a reverse beam 140 traveling back towards the lens 110. The optical lens 110 focuses the reverse beam 140 back as a converging beam 145 into the output fiber 2.

It is clear that only if the ends of the input fiber 1 and the output fiber 2 are located in the focal plane F, the forward beam 135 will be fully parallel. Although a certain
15 non-parallelism of the forward beam 135 will be acceptable for most applications, the deviation from the focal plane F should preferably be smaller than approximately 5% (preferably about 2%) of the focal length f. Otherwise, the optical arrangement will become increasingly complicated.

Since the optical attenuating filter 130 is situated between the lens 110 and the
20 optical mirror 120, as well the forward beam 135 as the reverse beam 140 will pass therethrough, so that both beams 135 and 140 can be attenuated. The attenuating filter 130 can comprise any attenuating means as known in the art such as the attenuating disc 6 as described in detail in the above cited EP-A-557542. The optical attenuating filter 130 can be provided rotatable, preferably around the optical
25 axis O, or fixed. Instead of changing the degree of attenuation by rotating an attenuating filter as disclosed in EP-A-557542, a longitudinal attenuating filter can be applied, whereby the degree of attenuating is varied by moving the optical attenuating filter 130 parallel to the principle plane P of the lens 110. Attenuating

filters with attenuation coating on a substrate (e.g. metallic coating) can be applied accordingly.

Between the optical attenuating filter 130 and the optical mirror 120, an optional polarization rotator 150 might be provided for reducing the polarization dependent attenuation of the optical attenuator 100. Preferably, the polarization rotator 150 is an optical Faraday rotator (as disclosed e.g. in EP-A-352002) with 45° polarization rotation, so that the total polarization rotation is $2 \times 45^\circ = 90^\circ$.

Fig. 3 shows a second embodiment of an optical attenuator 100 according to the invention, which substantially corresponds to the embodiment of Fig. 2. The input fiber 1 and the output fiber 2, however, are provided with angled fiber ends 200 and 210. The angle of the fiber ends determines the angle of radiation of the center beam (as normally the beam with highest intensity – indicated in Figs. 2 and 3 by a dotted center line in the light paths) and thus the distance between the lens 110 and the mirror 120. Increasing the angle of radiation will also increase the distance between the lens 110 and the mirror 120, thus allowing to achieve more space for inserting components between the lens 110 and the mirror 120. It is clear that the angle of the fiber end 210 has to be opposite to the angle of the fiber end 200, as depicted in Fig. 3.

In a preferred embodiment, the input fiber 1 and the output fiber 2 are directly coupled together, whereby a surface 230 at which the input fiber 1 and the output fiber 2 are mated together is located substantially within the optical axis O.

The fiber ends 200 and 210 are preferably angled towards each other as can be seen from Fig. 3. Preferably, the fiber ends 200 and 210 are each angled with respect to the optical axis O in a range smaller than approximately 10°, and preferably about 8°.

CLAIMS:

1. An optical system for imaging an input beam (3) from an input (1) to an output beam (145) at an output (2), comprising:
a lens (110) adapted for receiving the input beam from the input, and
5 a reflecting device (120) adapted for reflecting the input beam from the lens back to the lens,
whereby:
the lens is adapted for converging the beam reflected by the reflecting device to the output,
10 the input and the output are both located substantially in the focal plane (F) of the lens and off axis, with respect to the optical axis of the lens, on opposing sides from the optical axis (O) of the lens, and
the reflecting device is located on a side opposite, with respect to the principal plane (P) of the lens, to the side of the input and the output.
15 2. The optical imaging system of claim 1, wherein the reflecting device is a substantially plane mirror for reflecting a substantially parallel beam from the lens back to the lens.
3. The optical imaging system of claim 1 or 2, wherein:
a reflecting plane of the reflecting device is substantially parallel with the
20 principal plane of the lens; or
an angle ($\Delta\alpha$) is provided between the plane of the reflecting device and the principal plane of the lens for compensating a difference (Δy) in off axis location between the input and the output, or vice versa.
4. The optical imaging system according to any one of the above claims, wherein

the plane of the reflecting device substantially crosses the optical axis of the lens at a cross point of the optical axis of the lens with a beam of highest intensity from the input after passing the lens.

5. The optical imaging system (Fig. 3) according to any one of the above claims,
5 wherein the angle of radiation from the input provided with respect to the optical axis of the lens can be adjusted for adjusting the distance between the reflecting device and the lens.

6. The optical imaging system according to any one of the above claims,
wherein:

10 the input and the output are both located off axis in the focal plane of the lens, whereby the beam with highest intensity from the input is directed to the lens but not through the center of the lens;

the plane of the reflecting device is substantially parallel with the principal plane of the lens or slightly tilted in order to compensate a deviation in the
15 distances of the input and the output from the optical axis of the lens; and

the plane of the reflecting device substantially crosses the optical axis of the lens at the cross point of the optical axis of the lens with beam of highest intensity from the input after passing the lens.

7. The optical imaging system according to any one of the above claims,
20 wherein:

a first fiber end (1) represents the input and a second fiber end (2) represents the output, both preferably located tight together preferably in a holding device.

8. The optical imaging system (Fig. 3) of claim 7, wherein the fiber ends are
25 angled for adjusting the distance between the lens and the reflecting device by means of the angle of radiation.

9. The optical imaging system according to any one of the above claims, wherein:

5 a polarization rotator (150), preferably an optical Faraday rotator with preferably 45 degrees polarization rotation, is arranged between the lens and the reflecting device of the optical imaging system, so that an optical beam from the input to the output travels at least once through the polarization rotator, for reducing polarization dependent attenuation.

10. An optical system for modifying the characteristics of an optical beam, comprising:

10 an optical imaging system (110, 120) according to any one of the above claims, wherein the optical beam is applicable at the input thereof, and

a filter (130) arranged between the lens and the reflecting device of the optical imaging system, so that the optical beam travels at least once through the filter, whereby the filter preferably is an attenuator.

AMENDED CLAIMS

[received by the International Bureau on 10 August 2000 (10.08.00);
original claims 1-10 replaced by new claims 1-9 (3 pages)]

1. An optical system for imaging an input beam (3) from an input (1) to an output beam (145) at an output (2), comprising:

a lens (110) adapted for receiving the input beam from the input, and

- 5 a reflecting device (120) adapted for reflecting the input beam from the lens back to the lens,

whereby:

the lens is adapted for converging the beam reflected by the reflecting device to the output,

- 10 the input and the output are both located substantially in the focal plane (F) of the lens and off axis, with respect to the optical axis of the lens, on opposing sides from the optical axis (O) of the lens,

the reflecting device is located on a side opposite, with respect to the principal plane (P) of the lens, to the side of the input and the output, and

- 15 the angle of radiation from the input provided with respect to the optical axis of the lens can be adjusted for adjusting the distance between the reflecting device and the lens.

2. The optical imaging system of claim 1, wherein the reflecting device is a substantially plane mirror for reflecting a substantially parallel beam from the lens back to the lens.

3. The optical imaging system of claim 1 or 2, wherein:

a reflecting plane of the reflecting device is substantially parallel with the principal plane of the lens; or

- 25 an angle ($\Delta\alpha$) is provided between the plane of the reflecting device and the principal plane of the lens for compensating a difference (Δy) in off axis

location between the input and the output, or vice versa.

4. The optical imaging system according to any one of the above claims, wherein the plane of the reflecting device substantially crosses the optical axis of the lens at a cross point of the optical axis of the lens with a beam of highest intensity from the input after passing the lens.

5. The optical imaging system according to any one of the above claims, wherein:

the input and the output are both located off axis in the focal plane of the lens, whereby the beam with highest intensity from the input is directed to the lens but not through the center of the lens;

the plane of the reflecting device is substantially parallel with the principal plane of the lens or slightly tilted in order to compensate a deviation in the distances of the input and the output from the optical axis of the lens; and

the plane of the reflecting device substantially crosses the optical axis of the lens at the cross point of the optical axis of the lens with beam of highest intensity from the input after passing the lens.

6. The optical imaging system according to any one of the above claims, wherein:

a first fiber end (1) represents the input and a second fiber end (2) represents the output, both preferably located tight together preferably in a holding device.

7. The optical imaging system (Fig. 3) of claim 6, wherein the fiber ends are angled for adjusting the distance between the lens and the reflecting device by means of the angle of radiation.

8. The optical imaging system according to any one of the above claims, wherein:

a polarization rotator (150), preferably an optical Faraday rotator with preferably 45 degrees polarization rotation, is arranged between the lens and the reflecting device of the optical imaging system, so that an optical beam from the input to the output travels at least once through the polarization rotator, for reducing polarization dependent attenuation.

5

9. An optical system for modifying the characteristics of an optical beam, comprising:

an optical imaging system (110, 120) according to any one of the above claims, wherein the optical beam is applicable at the input thereof, and

10

a filter (130) arranged between the lens and the reflecting device of the optical imaging system, so that the optical beam travels at least once through the filter, whereby the filter preferably is an attenuator.

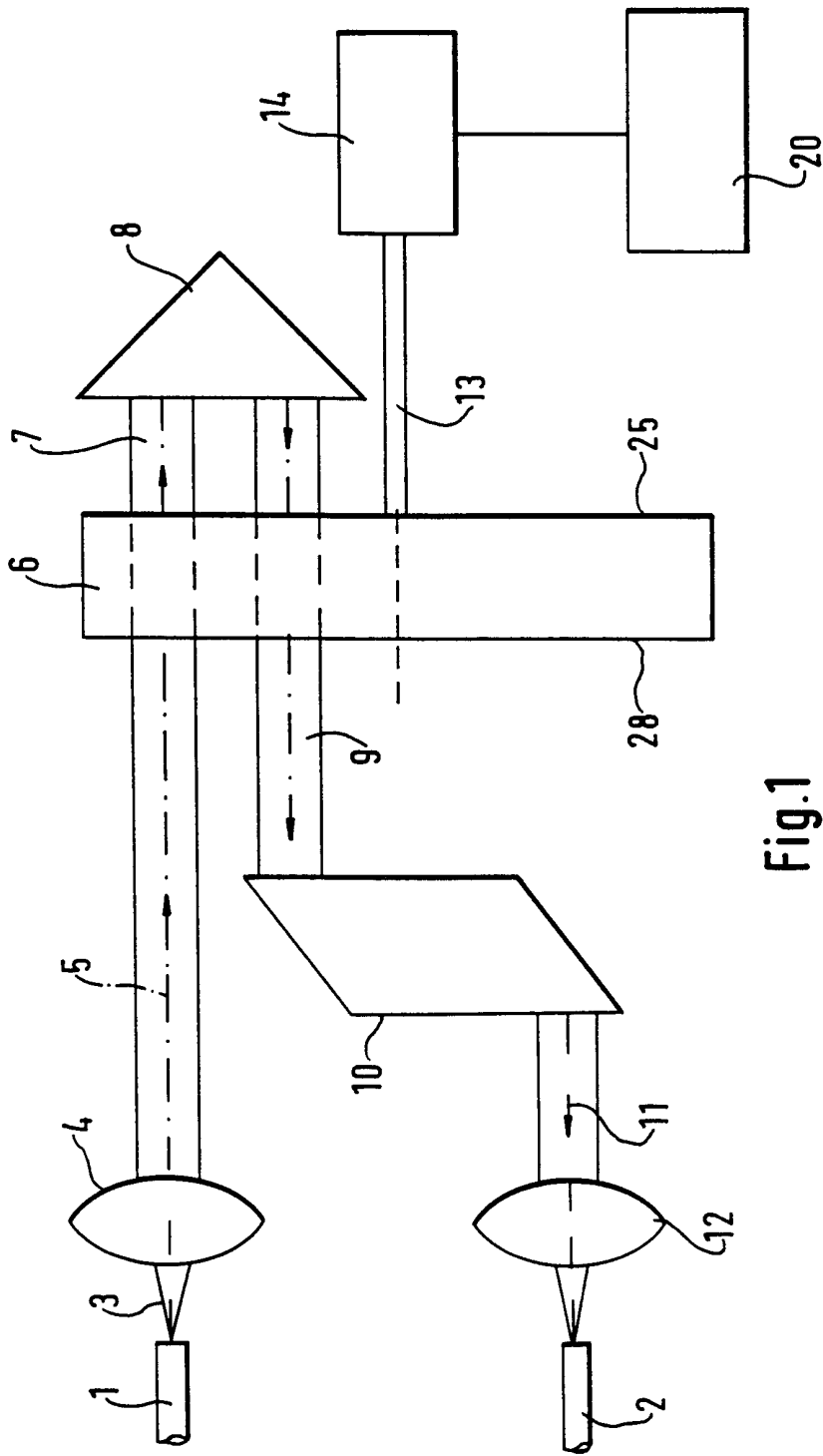

Fig.1

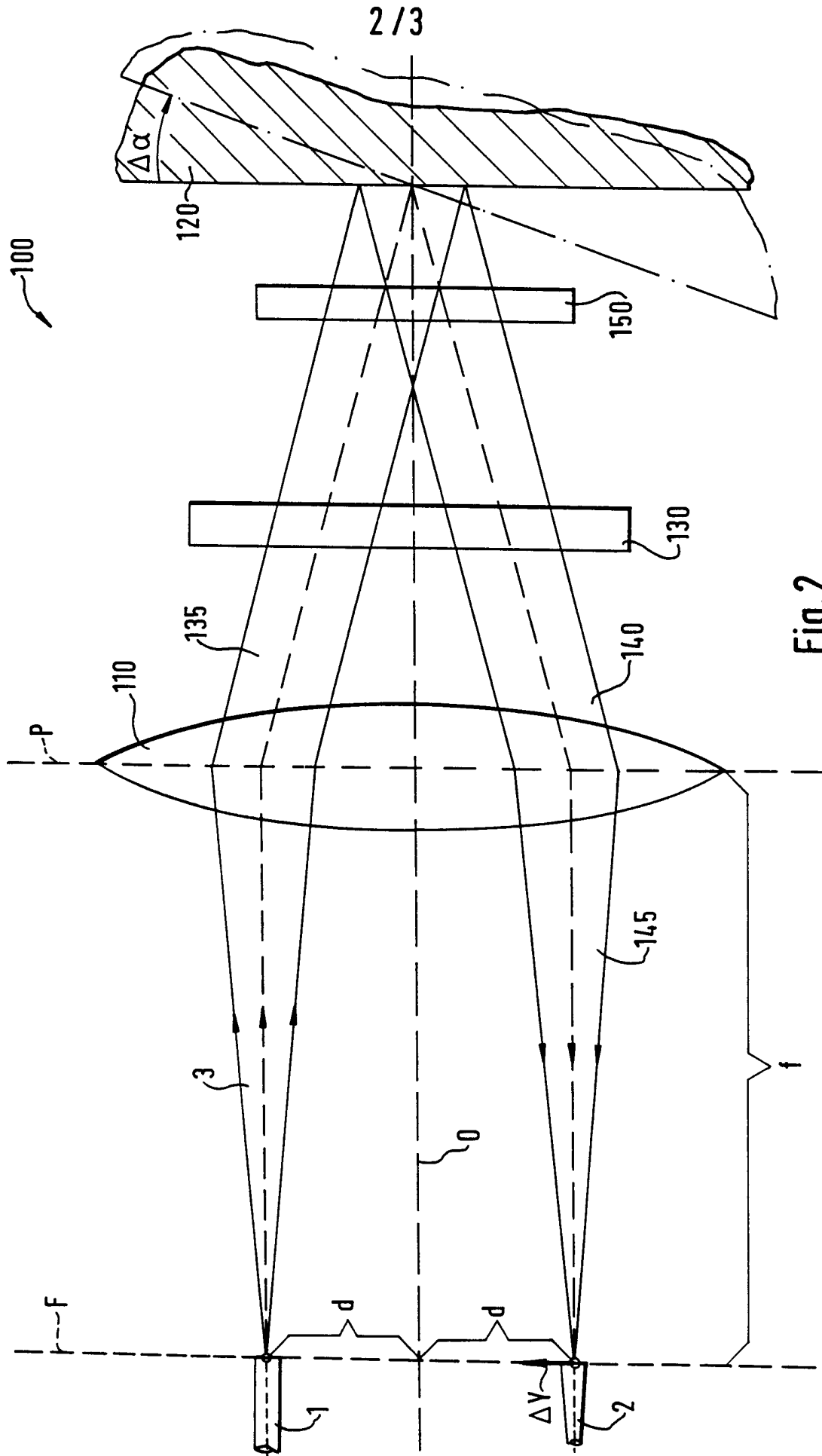

Fig. 2

INTERNATIONAL SEARCH REPORT

Inte. onal Application No
PCT/EP 99/07553

A. CLASSIFICATION OF SUBJECT MATTER
IPC 7 G02B26/02 G02B6/26

According to International Patent Classification (IPC) or to both national classification and IPC

B. FIELDS SEARCHED

Minimum documentation searched (classification system followed by classification symbols)
IPC 7 G02B

Documentation searched other than minimum documentation to the extent that such documents are included in the fields searched

Electronic data base consulted during the international search (name of data base and, where practical, search terms used)

C. DOCUMENTS CONSIDERED TO BE RELEVANT

Category *	Citation of document, with indication, where appropriate, of the relevant passages	Relevant to claim No.
X	US 4 304 460 A (TANAKA TSUTOMU ET AL) 8 December 1981 (1981-12-08) column 2, line 16 -column 5, line 7; figures 2-7 ---	1-7, 10
X	US 5 900 983 A (GOOSSEN KEITH WAYNE ET AL) 4 May 1999 (1999-05-04) column 4, line 23 -column 5, line 20 column 5, line 62 -column 6, line 33; figures 2B, 3B-3D ---	1, 2, 6, 10
X	US 5 745 271 A (MILLER DAVID ANDREW BARCLAY ET AL) 28 April 1998 (1998-04-28) column 2, line 66 -column 7, line 33; figure 1 ---	1, 4, 6, 10
	-/--	

Further documents are listed in the continuation of box C.

Patent family members are listed in annex.

* Special categories of cited documents :

- "A" document defining the general state of the art which is not considered to be of particular relevance
- "E" earlier document but published on or after the international filing date
- "L" document which may throw doubts on priority claim(s) or which is cited to establish the publication date of another citation or other special reason (as specified)
- "O" document referring to an oral disclosure, use, exhibition or other means
- "P" document published prior to the international filing date but later than the priority date claimed

- "T" later document published after the international filing date or priority date and not in conflict with the application but cited to understand the principle or theory underlying the invention
- "X" document of particular relevance; the claimed invention cannot be considered novel or cannot be considered to involve an inventive step when the document is taken alone
- "Y" document of particular relevance; the claimed invention cannot be considered to involve an inventive step when the document is combined with one or more other such documents, such combination being obvious to a person skilled in the art.
- "&" document member of the same patent family

Date of the actual completion of the international search

27 April 2000

Date of mailing of the international search report

08/05/2000

Name and mailing address of the ISA

European Patent Office, P.B. 5818 Patentlaan 2
NL - 2280 HV Rijswijk
Tel. (+31-70) 340-2040, Tx. 31 651 epo nl,
Fax: (+31-70) 340-3016

Authorized officer

THEOPISTOU, P

INTERNATIONAL SEARCH REPORT

International Application No

PCT/EP 99/07553

C.(Continuation) DOCUMENTS CONSIDERED TO BE RELEVANT		
Category	Citation of document, with indication, where appropriate, of the relevant passages	Relevant to claim No.
X	PATENT ABSTRACTS OF JAPAN vol. 1999, no. 02, 26 February 1999 (1999-02-26) & JP 10 307264 A (NEC CORP), 17 November 1998 (1998-11-17) abstract ---	1-5
A	US 5 915 063 A (COLBOURNE PAUL ET AL) 22 June 1999 (1999-06-22) claims 1,4,6; figures 1,2 ---	1-3,6
A	EP 0 557 542 A (HEWLETT PACKARD GMBH) 1 September 1993 (1993-09-01) cited in the application column 4, line 24 -column 6, line 38; figure 1 ---	1,3,6,10
A	US 5 321 774 A (BARNARD CHRIS ET AL) 14 June 1994 (1994-06-14) column 4, line 54 -column 6, line 16; figures 4,6 ---	1,9
A	US 5 953 477 A (MARPLE ERIC TODD ET AL) 14 September 1999 (1999-09-14) column 38, line 34 -column 39, line 18; figures 41-45 -----	7,8

INTERNATIONAL SEARCH REPORT

Information on patent family members

International Application No

PCT/EP 99/07553

Patent document cited in search report	Publication date	Patent family member(s)	Publication date
US 4304460 A	08-12-1981	JP 54121145 A	20-09-1979
		JP 55035346 A	12-03-1980
		JP 55043539 A	27-03-1980
		JP 1043286 B	20-09-1989
		JP 1571519 C	25-07-1990
		JP 55043540 A	27-03-1980
		JP 55087110 A	01-07-1980
		US 4498730 A	12-02-1985
US 5900983 A	04-05-1999	NONE	
US 5745271 A	28-04-1998	NONE	
JP 10307264 A	17-11-1998	IT MI980986 A	08-11-1999
US 5915063 A	22-06-1999	CA 2230664 A	15-07-1998
EP 0557542 A	01-09-1993	DE 69204984 D	26-10-1995
		DE 69204984 T	08-02-1996
		JP 6018791 A	28-01-1994
		US 5325459 A	28-06-1994
US 5321774 A	14-06-1994	CA 2125751 A	31-01-1995
US 5953477 A	14-09-1999	US 5764840 A	09-06-1998
		US 5878178 A	02-03-1999
		AU 2534197 A	01-10-1997
		CA 2248912 A	18-09-1997
		EP 0886796 A	30-12-1998
		WO 9734175 A	18-09-1997