

(19) **DANMARK**

(10) **DK/EP 3558609 T3**



Patent- og
Varemærkestyrelsen

(12) **Oversættelse af
europæisk patentskrift**

-
- (51) Int.Cl.: **B 27 M 3/18 (2006.01)** **B 25 B 27/02 (2006.01)** **B 27 M 3/00 (2006.01)**
E 04 F 15/02 (2006.01) **E 04 F 21/22 (2006.01)** **F 16 B 5/06 (2006.01)**
F 16 B 12/26 (2006.01)
- (45) Oversættelsen bekendtgjort den: **2022-01-03**
- (80) Dato for Den Europæiske Patentmyndigheds bekendtgørelse om meddelelse af patentet: **2021-10-20**
- (86) Europæisk ansøgning nr.: **17883594.8**
- (86) Europæisk indleveringsdag: **2017-12-20**
- (87) Den europæiske ansøgnings publiceringsdag: **2019-10-30**
- (86) International ansøgning nr.: **SE2017051305**
- (87) Internationalt publikationsnr.: **WO2018117953**
- (30) Prioritet: **2016-12-22 SE 1651731**
- (84) Designerede stater: **AL AT BE BG CH CY CZ DE DK EE ES FI FR GB GR HR HU IE IS IT LI LT LU LV MC MK MT NL NO PL PT RO RS SE SI SK SM TR**
- (73) Patenthaver: **Välinge Innovation AB, Prästavägen 513, 263 64 Viken, Sverige**
- (72) Opfinder: **FRANSSON, Jonas, Allerumsvägen 317, SE-254 76 Allerum, Sverige**
BLOMGREN, Andreas, Lyckornavägen 33, SE-459 33 Ljungskile, Sverige
ERIKSON, Karl, Adlersborgsvägen 11, SE-451 32 Uddevalla, Sverige
- (54) Benævnelse: **INDRETNING TIL INDSÆTTELSE AF EN FER I EN INDSÆTTELSESNOT I ET PANEL**
- (56) Fremdragne publikationer:
EP-A1- 1 650 375
EP-A1- 1 674 223
EP-A1- 2 689 904
WO-A1-2009/124517
WO-A1-2010/087752
WO-A2-2007/109787
BR-A2- PI0 906 645
US-A- 3 381 730
US-A1- 2009 193 748
US-A1- 2010 313 714
US-A1- 2012 073 235
US-A1- 2013 042 563
US-A1- 2014 138 422
US-A1- 2016 129 573

DESCRIPTION

Field of the Invention

[0001] Embodiments of the present invention relate to a handheld device for inserting a tongue into an insertion groove in a panel. Such a device is known from the document EP1674223 A1.

Background of the Invention

[0002] A conventional furniture product may be assembled by a plurality of elements or panels. The panels may be assembled with a mechanical locking device, such as disclosed in, for example, WO 2012/154113 A1. The product comprises a first panel connected perpendicularly to a second panel by a mechanical locking device comprising, an edge tongue at the first panel, an edge groove at the second panel and a flexible tongue in an insertion groove.

[0003] WO 2015/038059 discloses a product assembled by a plurality of panels that are locked by mechanical locking devices comprising a flexible tongue in an insertion groove.

[0004] The locking devices of the panels are generally produced in a production line by a continuous production process, comprising a number of milling tools. The edge groove and the insertion groove may extend contiguously from a front edge to a back edge of the panel. The edge groove is preferably covered at the front edge by a decorative layer. The edge groove and the insertion groove may also end before the front edge and/or the back edge as disclosed in, e.g., SE 1650135-5 and WO 2017/135874.

[0005] Embodiments of the present invention address a need to provide an improved device for inserting a tongue into an insertion groove in a panel.

Summary of the Invention

[0006] Accordingly, embodiments of the present invention preferably seek to mitigate, alleviate or eliminate one or more deficiencies, disadvantages or issues in the art, such as the above-identified, singly or in any combination by providing a device for inserting a tongue in an insertion groove of a panel. The device is preferably handheld or configured to be attached to an assembling table.

[0007] A further object of embodiments of the invention is to provide a device with great flexibility which is suitable for short series production.

[0008] At least some of these and other objects and advantages that will be apparent from the

description have been achieved by an aspect of the invention including a handheld device for inserting a tongue into an insertion groove in a panel, such as a furniture panel or a floor panel. The device comprises a first part comprising a power unit configured for driving a puncher. The device comprises a second part, which is connected to the first part. The second part comprises the displaceable puncher and a guiding device which is configured to guide the displaceable puncher, and the tongue. An outer edge of the second part comprises a first positioning element and a second positioning element. The first positioning element and the second positioning element are configured to be positioned at least partly in the insertion groove during an insertion of a tongue into the insertion groove. The displaceable puncher is configured to displace a tongue from the handheld device to an inserted position in the insertion groove.

[0009] The second part is preferably configured such that the tongue is displaceable between the first positioning element and the second positioning element.

[0010] An inner surface of the first positioning element is preferably positioned at a distance from an inner surface of the second positioning element. The distance is preferably essentially equal to a longitudinal length of the tongue.

[0011] An outer width of the puncher, which is configured to be displaced between the first positioning element and the second positioning element, may be essentially equal to a longitudinal length of the tongue.

[0012] The tongue may be of an elongated shape, wherein a longitudinal direction of the tongue is perpendicular to a displacement direction of the displaceable puncher.

[0013] The insertion groove may be of an elongated shape, wherein a longitudinal direction of the insertion groove is parallel to an edge of the panel.

[0014] The tongue may be of an elongated shape, wherein a longitudinal direction of the tongue, in the inserted position, is parallel with the longitudinal direction of the insertion groove.

[0015] The device may comprise an attachment device and the device may be configured to be attached to a holding fixture or an assembling table by the attachment device.

[0016] The second part may comprise a magazine for two or more of said tongue.

[0017] The magazine may be configured for storing a second of said tongue above a first of said tongue, wherein the magazine extends essentially perpendicular to the second direction.

[0018] The magazine may be configured such that charging of a tongue into the magazine in the correct orientation is facilitated. An embodiment may comprise a top plate with an opening which is adapted to an outer shape of the tongue, such that the tongue may only be charged in a correct position.

[0019] The device may comprise a handle, preferably at the first part.

[0020] The first part may comprise a trigger for activating a stroke of the displaceable puncher.

[0021] The handle may comprise a trigger for activating a stroke of the displaceable puncher.

[0022] The groove is of an elongated shape and extends with a length direction along the upper surface of the panel.

[0023] The tongue may be of an elongated shape and a length direction of the tongue may be parallel with the length direction of the insertion groove.

[0024] The tongue may be of an elongated shape and a length direction of the tongue may be perpendicular to a displacement direction of the displaceable puncher.

[0025] The tongue may be of an elongated shape and may comprise a first long edge and a second-long edge.

[0026] The tongue may be a flexible tongue and made of, e.g., a polymer and preferably comprising a reinforcement material, such as a fibre, e.g., glasfiber.

[0027] The tongue may comprise a bendable part at the first long edge and preferably a groove adjacent the bendable part. The bendable part may be configured to be pushed into the groove adjacent the bendable part. The tongue may comprise several of said bendable part and preferably several of said groove.

[0028] The tongue may comprise a polymer material and is preferably produced by injection moulding.

[0029] The edge groove and the insertion groove may extend continuously from a front edge to a back edge of the panel.

Brief Description of the Drawings

[0030] These and other aspects, features and advantages of which embodiments of the invention are capable of, will be apparent and elucidated from the following description of embodiments of the present invention, reference being made to the accompanying drawings, in which

FIG 1 shows in a 3D-view an embodiment of the handheld device according to an embodiment of the invention.

FIG 2 shows a crosscut in a side view of an embodiment of the handheld device according to

an embodiment of the invention.

FIGS 3A-3B show an enlargement of parts of the embodiment of the device shown in FIG 2 according to an embodiment of the invention.

FIG 4 shows an enlargement of parts of the embodiment of the device shown in FIG 2 according to an embodiment of the invention.

FIGS 5A-5B shows in a 3D-view embodiments of parts of an embodiment of the second part.

FIGS 6A-6B shows in a 3D-view embodiments of parts of an embodiment of the first part and the second part, respectively.

FIGS 7A-7D show embodiments of a tongue according to embodiments of the invention.

FIGS 8A-8D show an embodiment of a tongue according to an embodiment of the invention.

FIGS 9A-9D show embodiments of the panel according to embodiments of the invention.

Description of Embodiments

[0031] Specific embodiments of the invention will now be described with reference to the accompanying drawings. This invention may, however, be embodied in many different forms and should not be construed as limited to the embodiments set forth herein; rather, these embodiments are provided so that this disclosure will be thorough and complete, and will fully convey the scope of the invention to those skilled in the art. The terminology used in the detailed description of the embodiments illustrated in the accompanying drawings is not intended to be limiting of the invention. In the drawings, like numbers refer to like elements.

[0032] Embodiments of the handheld device are shown in FIG 1 to FIG 6B that may improve an insertion of a tongue into an insertion groove of a panel.

[0033] FIG 1 shows in a 3D-view an embodiment of the handheld device and FIG 2 shows a crosscut of the embodiment in a side view. The embodiment comprises a first part 10 comprising a power unit 16 which is configured for driving a puncher 14 and a second part 12, which is connected to the first part 10.

[0034] FIG 3A shows that the second part comprises the displaceable puncher 14 and a guiding device 13 which is configured to guide the displaceable puncher 14 and the tongue 30. An outer edge 60 of the second part 12 comprises a first positioning element 54 and a second positioning element 55. The first positioning element 54 and the second positioning element 55 are configured to be positioned at least partly in the insertion groove 20 during an insertion of the tongue into the insertion groove 20, the displaceable puncher 14 is configured to displace

the tongue 30 from the handheld device to an inserted position in the insertion groove 20.

[0035] FIG 3A shows an enlargement of some of the parts shown in FIG 2 during an insertion of the tongue 30 into the insertion groove 20. FIG 3B shows the tongue 30 in the inserted position in the insertion groove 20 at an edge 3 of the panel 1.

[0036] The second part may be configured such that the tongue 30 is displaceable between the first positioning element 54 and the second positioning element 55.

[0037] The panel 1 may have an upper surface 11 extending in a first direction 91 and a depth direction of the insertion groove may extend in a second direction 92 at an angle 93 to the first direction 91. The angle 93 may be in the range of about 0° to about 90°, preferably in the range of about 10° to about 45°, or is about 25°.

[0038] The handheld device is during the insertion preferably arranged in a position in which the guiding device extends in a direction parallel to the depth direction of the insertion groove.

[0039] The second part 12 may comprise a magazine 15 for two or more of said tongues 30. The magazine may be configured for storing a second of said tongue above a first said tongue and the magazine 15 may be extending essentially perpendicular to a displacement direction of the displaceable puncher 14.

[0040] The second part may comprise a lower structural part 41. The magazine 15 may extend essentially perpendicular to the lower structural part 41. An embodiment of the magazine is shown in a crosscut side-view in FIG 4. The magazine comprises a magazine frame 42 and a feeding device 62 configured to feed tongues arranged in the magazine frame 42. The feeding device is attached pivotable 64 to a lower part by a hinge 63 in order to facilitate charging of tongues in the magazine frame 42.

[0041] The guiding device 13 may comprise a flexible guiding element 56 at an outer part of the guiding device. The flexible guiding element is configured to guide the tongue 30 into the insertion groove 20.

[0042] The insertion groove 20 may be of an elongated shape with a longitudinal direction parallel to the edge 3 of the panel.

[0043] The tongue 30 may be of an elongated shape and a length direction of the tongue may be parallel with the longitudinal direction of the insertion groove 20.

[0044] The tongue 30 may be of an elongated shape and a length direction of the tongue may be perpendicular to a displacement direction of the displaceable puncher 14.

[0045] A lower part of an embodiment of the second part is shown in FIG 5A in a 3D-view. The embodiment shows that an inner surface 51 of the first positioning element 54 is preferably

positioned at a distance from an inner surface 52 of the second positioning element 55. The distance is preferably equal to a longitudinal length of the tongue. The second part 12 comprises a lower structural part 41.

[0046] An outer width of the puncher, which is configured to be displaced between the first positioning element and the second positioning element, may be essentially equal to a longitudinal length of the tongue.

[0047] FIG 5B shows in a 3D-view an embodiment of the magazine frame 42. The magazine may be attached to the lower part shown in FIG 5A. The frame is configured for charging of tongues through an opening at upper part of the magazine frame.

[0048] The magazine 15 may be configured such that charging of a tongue into the magazine frame 42 in the correct orientation is facilitated. An embodiment of the magazine frame may comprise a top plate 43 with a charging opening 44 which is adapted to an outer shape of the tongue 30, such that the tongue may only be charged in a correct position.

[0049] FIG 6A shows in a 3D-view a feeding device 62 configured to feed tongues arranged in the magazine frame 42 shown in FIG 5B. The feeding device comprises a displaceable element 65 which is configured to displace the tongues towards the displaceable puncher 14. The displaceable element may be springloaded. The feeding device may be attached pivotable 64 to the lower part shown in FIG 5A by a hinge 63 in order to facilitate charging of tongues in the magazine frame 42.

[0050] The feeding device 62 may be pivoted away 64 from a charging opening 44 of the magazine frame 44 before a tongue is charged into the magazine frame.

[0051] A tongue set comprising two or more of said tongue 30 may be connected to each other by a releasable connection, such as a strip, a pin or a welding. The releasable connection may be removed from the tongue set when the tongue set is charged into the magazine frame 42. The releasable connection is preferably configured such that a front tongue of the tongue set is released when the front tongue is displaced by the displaceable puncher 14.

[0052] FIG 6B shows, in a 3D-view, an embodiment of the first part 10. The embodiment comprises a handle 50 at a back part, another handle 50' at a front part and a trigger 61. The first part may be attached to the lower structural part 41 of the second part shown in FIG 5A.

[0053] Embodiments may comprise exchangeable embodiments of the second part, wherein each embodiment of the second part is configured for a specific tongue embodiment. A first exchangeable embodiment of the second part may be configured for a tongue with a first longitudinal length and a second exchangeable embodiment of the second part is configured for a tongue with a second longitudinal length. The second longitudinal length may be shorter or longer than the first longitudinal length.

[0054] Embodiments of the tongue 30, which may be displaceable in an insertion groove 20 as shown in FIGS 9A-9D, are shown in FIGS 7A-7D. A first embodiment of the tongue, which is shown in FIGS 7A-7B, comprises bendable protruding parts 31 at a first long edge of the tongue. The first embodiment is shown in a relaxed state in FIG 7A and in a compressed state in FIG 7B. A second long edge of the tongue is preferably essentially straight. The first embodiment may be inserted into the insertion groove with the bendable protruding parts facing towards a bottom of the insertion groove and the second edge extending beyond an opening of the insertion groove. A second embodiment of the tongue, which is shown in FIG 7C in a relaxed state, is of an elongated shape and flexible. The second embodiment comprises a recess 37 at a first long edge of the tongue and a second edge which is essentially straight. The recess is decreased in a compressed state of the second embodiment. The second embodiment may be inserted into the insertion groove with the recess 37 facing towards a bottom of the insertion groove and the second edge extending beyond an opening of the insertion groove. A third embodiment of the tongue, which is shown in FIG 7D, comprises a first part 38, which is flexible and configured to be compressed, and a second part which is rigid 39. The first part may be arranged in the insertion groove and the second part may partly extend beyond an opening of the insertion groove.

[0055] The tongue may be configured as any of the embodiments of the displaceable tongue disclosed in, e.g., WO 2006/043893 and WO 2007/015669, the entire contents of which are hereby expressly incorporated by reference.

[0056] The tongue may be flexible and made of, e.g., a polymer and preferably comprising a reinforcement material, such as a fibre, e.g., glasfiber.

[0057] Another embodiment of the tongue 30 is shown in FIGS 8A-8D. The tongue is of an elongated shape and comprises a first short edge 34, an opposite second short edge 36, first long edge and a second long edge 32. FIG 8D shows an enlargement of the encircled area A indicated in FIG 8A. The tongue comprises several bendable parts 31 at the first long edge and a groove 33 at each bendable part 31. The tongue comprises a polymer material and is preferably produced by injection moulding. The bendable part 31 is configured to be pushed into the groove 33 in a compressed state of the tongue.

[0058] FIG 8A shows an embodiment of tongue which is connected to several tongues (not shown) in a tongue blank by a first rail 35 at the first short edge 34 and by a second rail 37 at the second short edge 36. The first rail and the second rail extend in a length direction perpendicular to the tongue. The tongue may be connected to the first rail and/or the second rail, which may be casting gates, by a first and a second casting gate, respectively. The tongues are separated from the first and/or the second rail before a stacking in magazine configured to be attached to the device.

[0059] FIG 8B and FIG 8C show the tongue 30 in a cross cut view. The tongue is in FIG 8B in a relaxed state and in FIG 8C in a compressed state. A distance between an outer part of the

bendable part 31 and the second long edge 32 is shorter in the compressed state compared to in the relaxed state.

[0060] The tongue is preferably configured to be inserted into an insertion groove of a panel for locking the panel to an adjacent panel.

[0061] FIGS 9A-9D shows embodiments of the panel 1, each comprising an embodiment of the tongue 30 inserted in an embodiment of the insertion groove 20, connected to an adjacent panel 2. The embodiments of the panel shown in FIGS 9A-9D may be furniture panels. The embodiment of the panel shown in FIG 9C may also be a floor panel.

[0062] FIG 9A shows the panel 1 arranged perpendicular to an adjacent panel 2 and locked to the adjacent panel in a first direction and in a second direction, which is perpendicular to the first direction. The panel comprising an edge groove 21 at an upper surface of the panel. The edge groove 21 is of a longitudinal shape and extends along an edge of the panel 1. The edge groove may comprise said insertion groove 20, which extends along the edge groove, comprising said tongue 30. The adjacent panel comprises an edge tongue 22 which comprises a tongue groove 10 extending along an edge of the adjacent panel. The tongue 30 is configured to cooperate with the tongue groove 10 for locking together the panel 1 with the adjacent panel 2 in the first direction. The edge tongue 22 is configured to cooperate with the edge groove 21 for locking together the panel 1 with the adjacent panel 2 in the second direction.

[0063] FIG 9B shows the panel 1 arranged perpendicular to an adjacent panel 2 and locked to the adjacent panel in a first direction and in a second direction, which is perpendicular to the first direction. The adjacent panel comprising an edge groove 21 at an upper surface of the adjacent panel. The edge groove 21 is of a longitudinal shape and extends along an edge of the adjacent panel 1. The edge groove comprises a tongue groove 10. The panel comprises an edge tongue 22 which comprises said insertion groove 20 comprising said tongue 30. The insertion groove extends along the edge tongue. The tongue 30 is configured to cooperate with the tongue groove 10 for locking together the panel 1 with the adjacent panel 2 in the first direction. The edge tongue 22 is configured to cooperate with the edge groove 21 for locking together the panel 1 with the adjacent panel 2 in the second direction.

[0064] FIG 9C shows the panel 1 arranged parallel to an adjacent panel 2 and locked to the adjacent panel in a first direction and in a second direction, which is perpendicular to the first direction. The panel comprising said insertion groove 20 which extends along an edge of the panel. The edge comprises a strip protruding from the edge and the strip comprises an upwardly protruding locking element. The adjacent panel 2 comprises a tongue groove 10 extending along an adjacent edge of the adjacent panel 2. The adjacent edge comprises a locking groove with an opening facing downwards. The tongue 30 is configured to cooperate with the tongue groove 10 for locking the panel to the adjacent panel in a first direction and the locking element is configured to cooperate with the locking groove for locking the panel to the adjacent panel in the second direction. An embodiment of the said first and second panel

comprises the insertion groove 20 at the adjacent edge of the adjacent panel and the tongue groove 10 at the edge of the panel.

[0065] FIG 9D shows an embodiment of the panel and the adjacent panel shown in FIG 8A in a 3D-view. The edge tongue 22 extends along the edge 4 of the adjacent panel and ends before an adjacent edge 6 of the adjacent panel 2. The edge groove 21 extends along the edge 3 of the panel 1 and ends at a side wall 23 before an adjacent edge of the 5 of the panel 1.

[0066] A core material of embodiments of the panel and the adjacent panel described above may comprises a wood fibre based board, such as a HDF, MDF, plywood, solid wood or particleboard, or a reinforced plastic board or a wood fibre composite board. The core may be provided with a decorative layer.

REFERENCES CITED IN THE DESCRIPTION

Cited references

This list of references cited by the applicant is for the reader's convenience only. It does not form part of the European patent document. Even though great care has been taken in compiling the references, errors or omissions cannot be excluded and the EPO disclaims all liability in this regard.

Patent documents cited in the description

- [EP1674223A1 \[0001\]](#)
- [WO2012154113A1 \[0002\]](#)
- [WO2015038059A \[0003\]](#)
- [SE16501355 \[0004\]](#)
- [WO2017135874A \[0004\]](#)
- [WO2006043893A \[0055\]](#)
- [WO2007015669A \[0055\]](#)

PATENTKRAV

1. Håndholdt indretning (80) til indsættelse af en fer (30) i en indsættelsesnot (20) i et panel (1), hvor
 - den håndholdte indretning omfatter en første del (10), der omfatter en effektenhed (16), som er konfigureret til at drive en perforator (14),
 - den håndholdte indretning omfatter en anden del (12), der er forbundet med den første del (10),
 - den anden del omfatter den forskydelige perforator (14) og en styreindretning (13), som er konfigureret til at styre den forskydelige perforator (14) og feren (30),
 - 10 **kendetegnet ved, at** en yderkant (60) af den anden del (12) omfatter et første positioneringselement (54) og et andet positioneringselement (55),
 - at** det første positioneringselement (54) og det andet positioneringselement (55) er konfigureret til mindst delvist at blive positioneret i indsættelsesnoten (20) under en indsættelse af feren i indsættelsesnoten,
 - 15 **at** den forskydelige perforator (14) er konfigureret til at forskyde feren (30) fra den håndholdte indretning til en indsat position i indsættelsesnoten (20).
 2. Håndholdt indretning ifølge krav 1, hvor den anden del er konfigureret således, at feren (30) kan forskydes mellem det første positioneringselement (54) og det andet positioneringselement (55).
 - 20 3. Håndholdt indretning ifølge krav 1 eller 2, hvor en inderflade (51) af det første positioneringselement (54) er positioneret i en afstand fra en inderflade (52) af det andet positioneringselement (55).
 4. Håndholdt indretning ifølge et hvilket som helst af kravene 1-3, hvor den anden del (12) omfatter et magasin (15) til to eller flere af ferene (30).
 - 25 5. Håndholdt indretning ifølge krav 4, hvor magasinet (15) er konfigureret til at opbevare en anden fer oven over en første fer.

6. Håndholdt indretning ifølge et hvilket som helst af kravene 1-5, hvor feren (30) udviser en langstrakt form, hvor en længderetning af feren er vinkelret på en forskydningsretning for den forskydelige perforator (14).
7. Håndholdt indretning ifølge et hvilket som helst af kravene 1-6, hvor
5 indsættelsesnoten udviser en langstrakt form, hvor en længderetning af indsættelsesnoten er parallel med en kant af panelet.
8. Håndholdt indretning ifølge krav 7, hvor feren (30) udviser en langstrakt form, hvor en længderetning af feren, i den indsatte position, er parallel med indsættelsesnotens (20) længderetning.
- 10 9. Håndholdt indretning ifølge et hvilket som helst af kravene 1-8, hvor indretningen omfatter et greb (50), fortrinsvis i den første del.
10. Håndholdt indretning ifølge et hvilket som helst af kravene 1-9, hvor den første del omfatter en udløser (61) til aktivering af et slag af den forskydelige perforator (14).



DRAWINGS

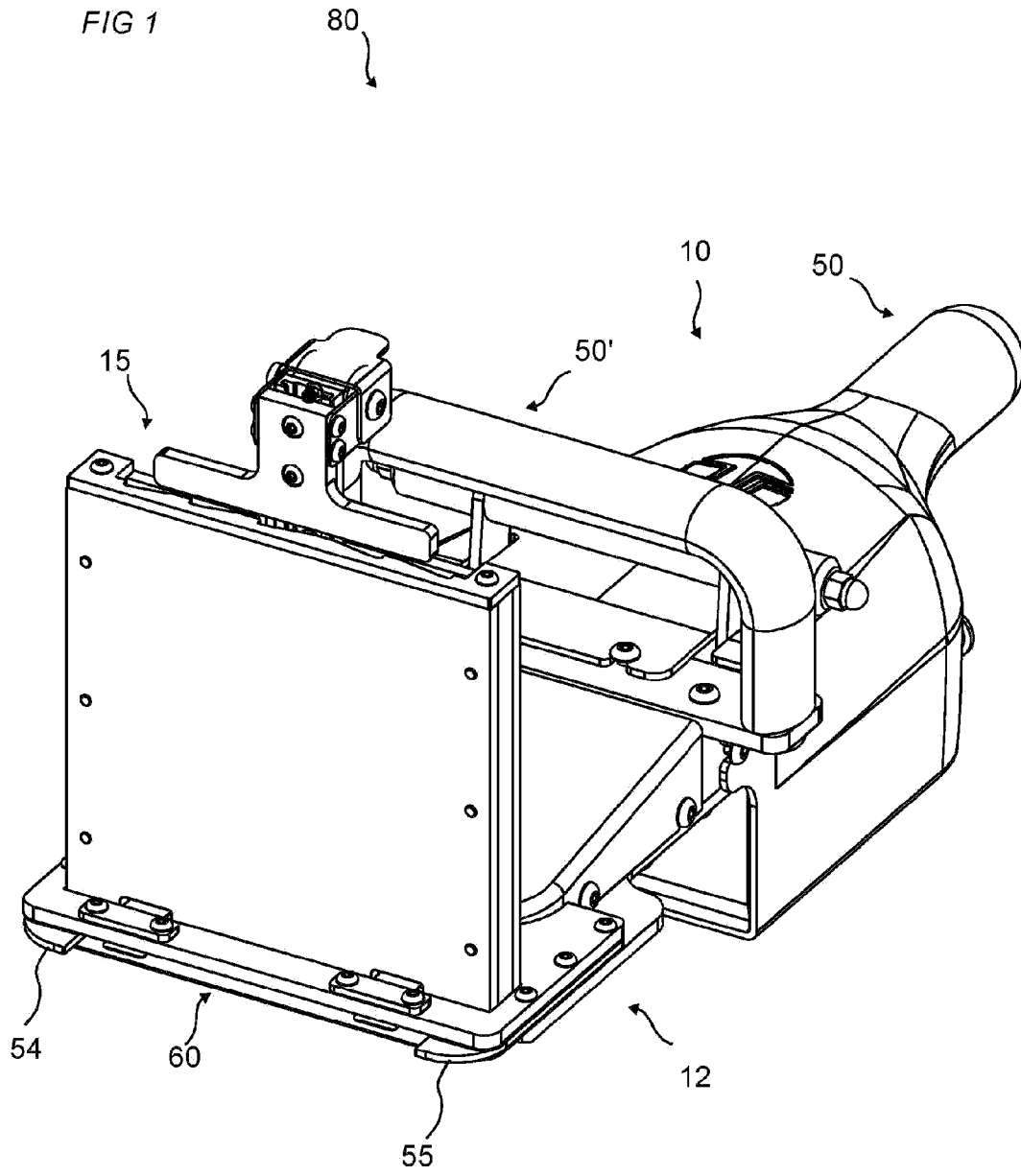

FIG 2

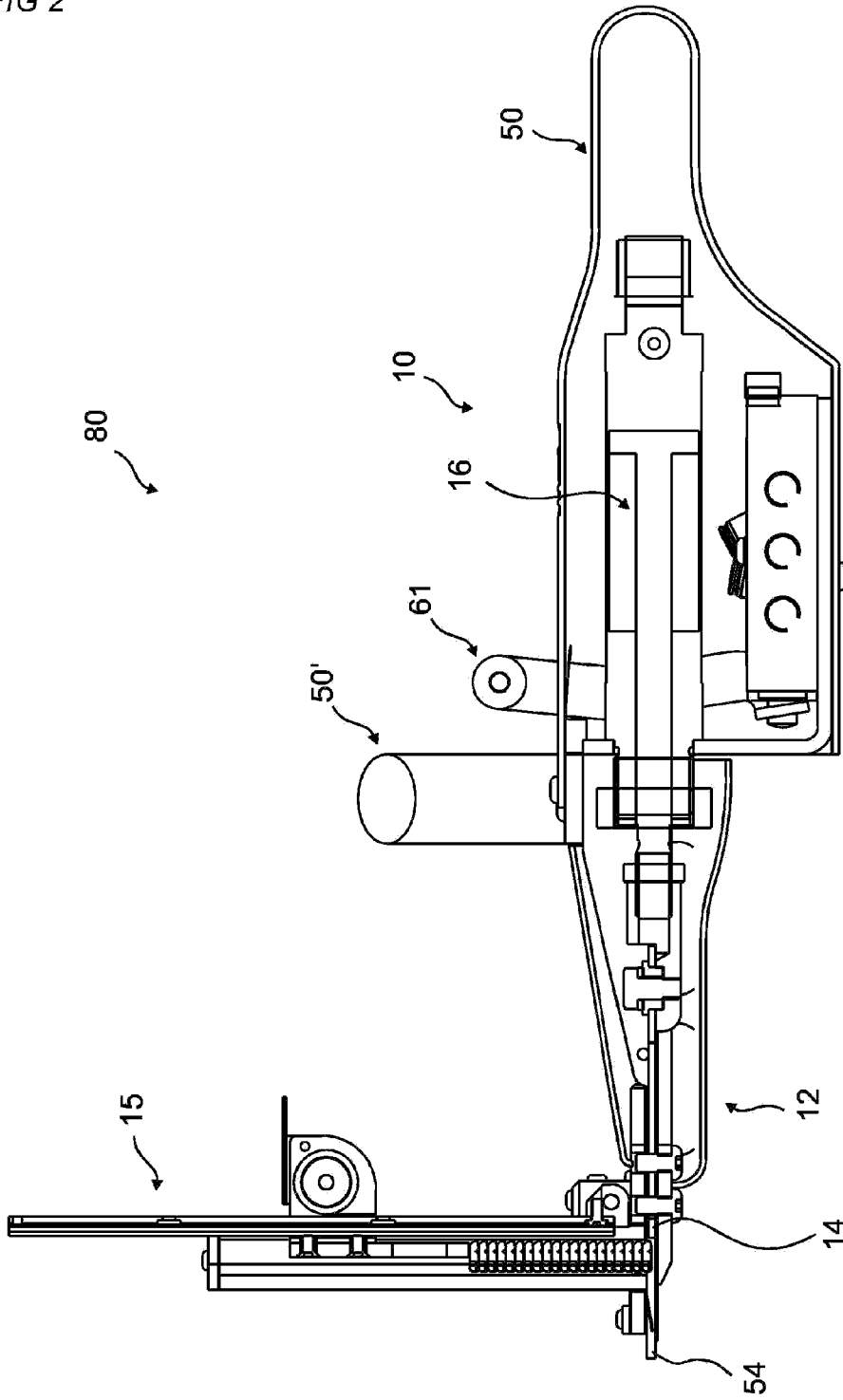

FIG 3A

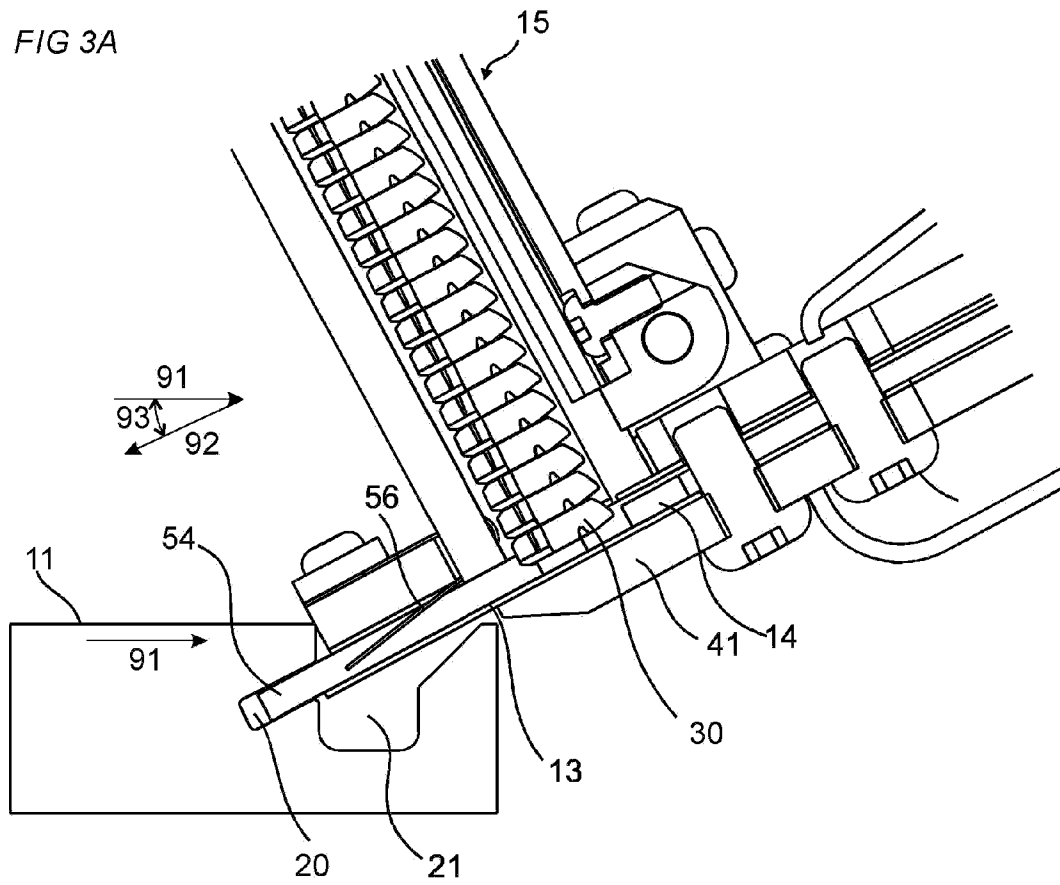

FIG 3B

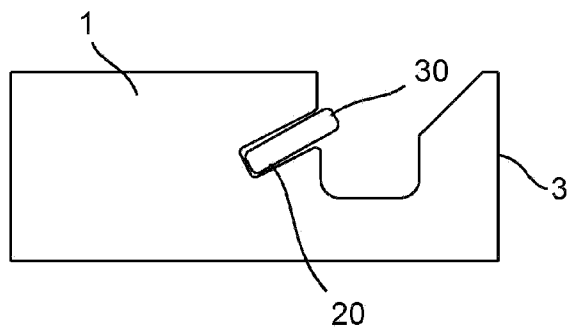

FIG 4

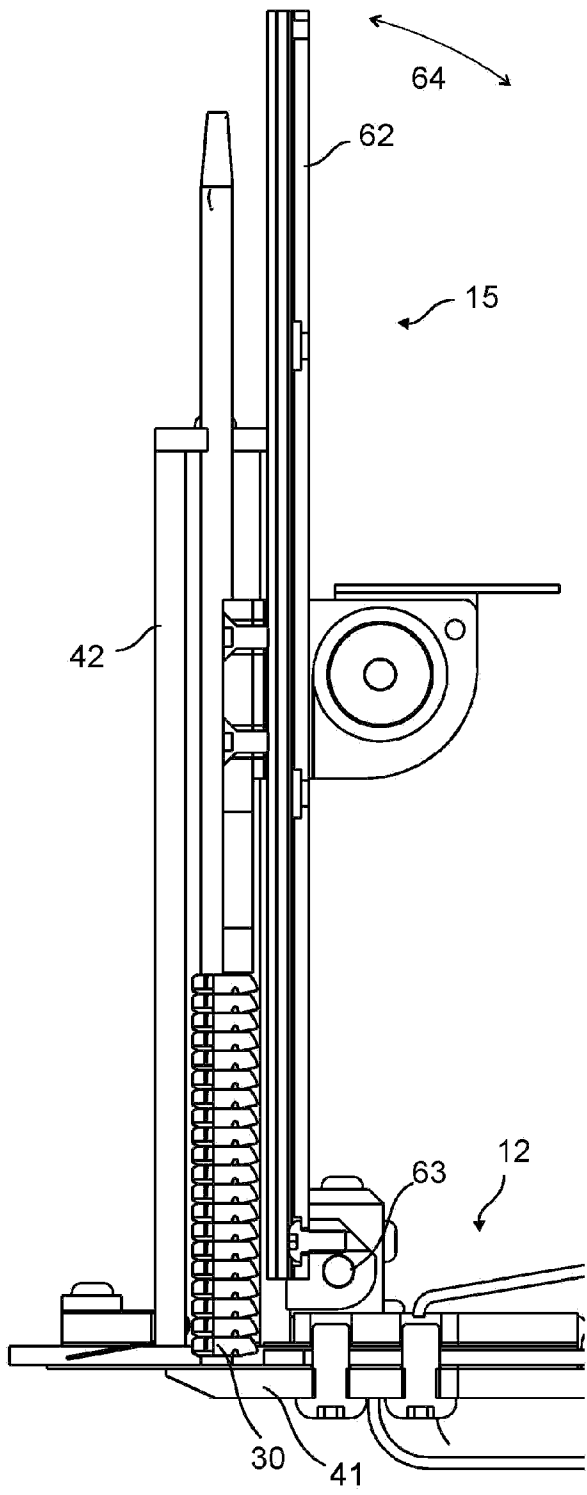

FIG 5A

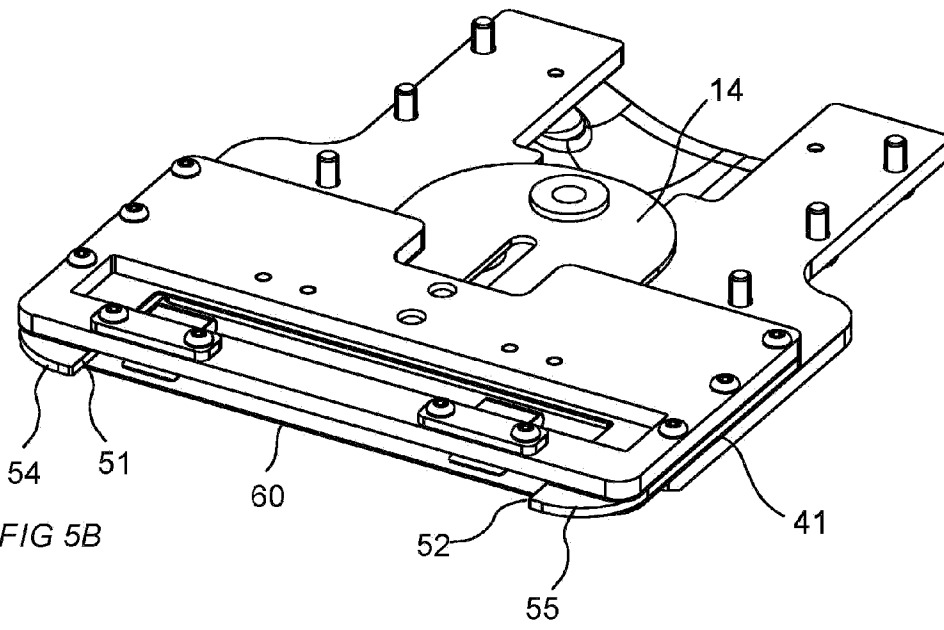

FIG 5B

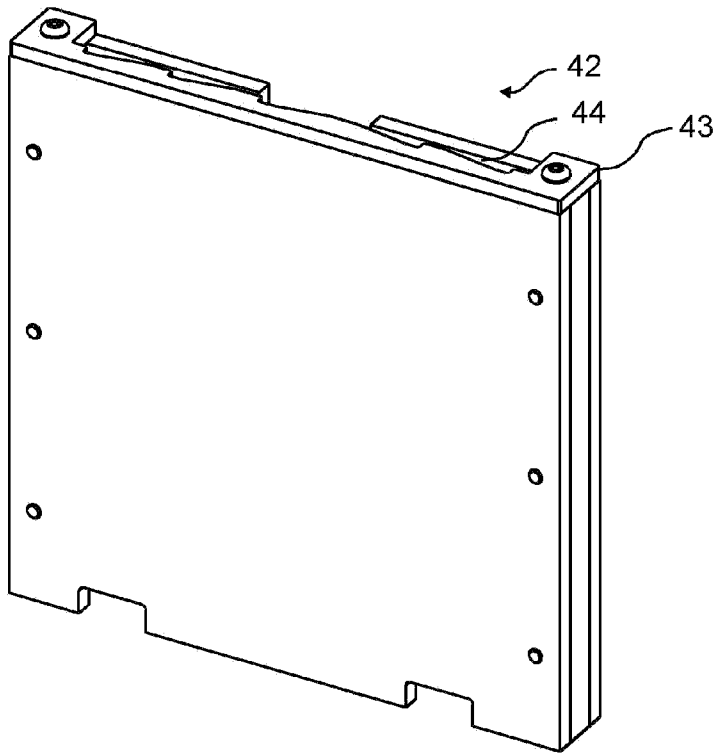

FIG 6A

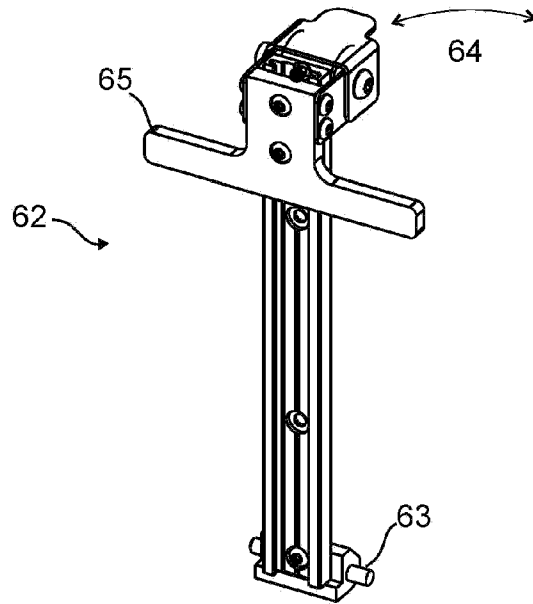

FIG 6B

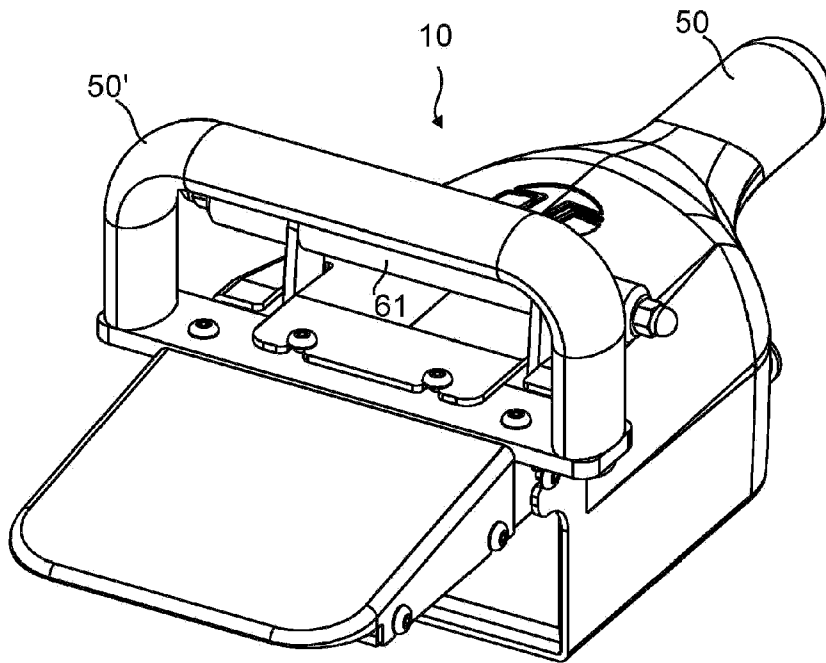

FIG 7A

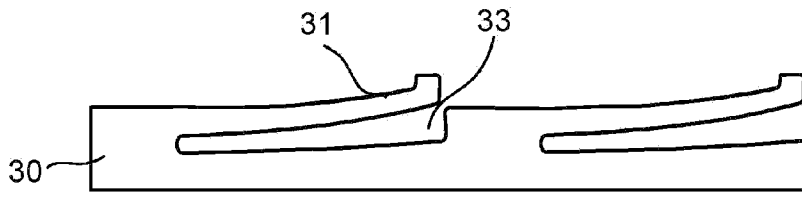

FIG 7B

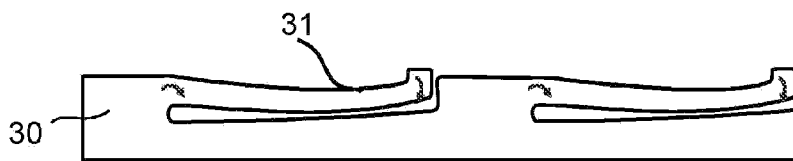

FIG 7C

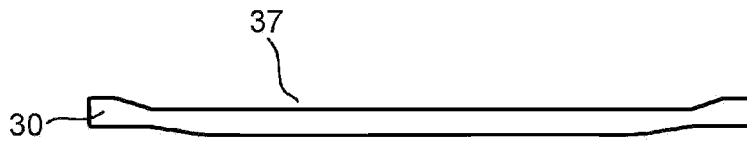
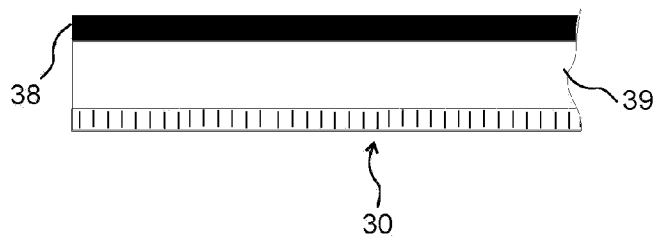

FIG 7D



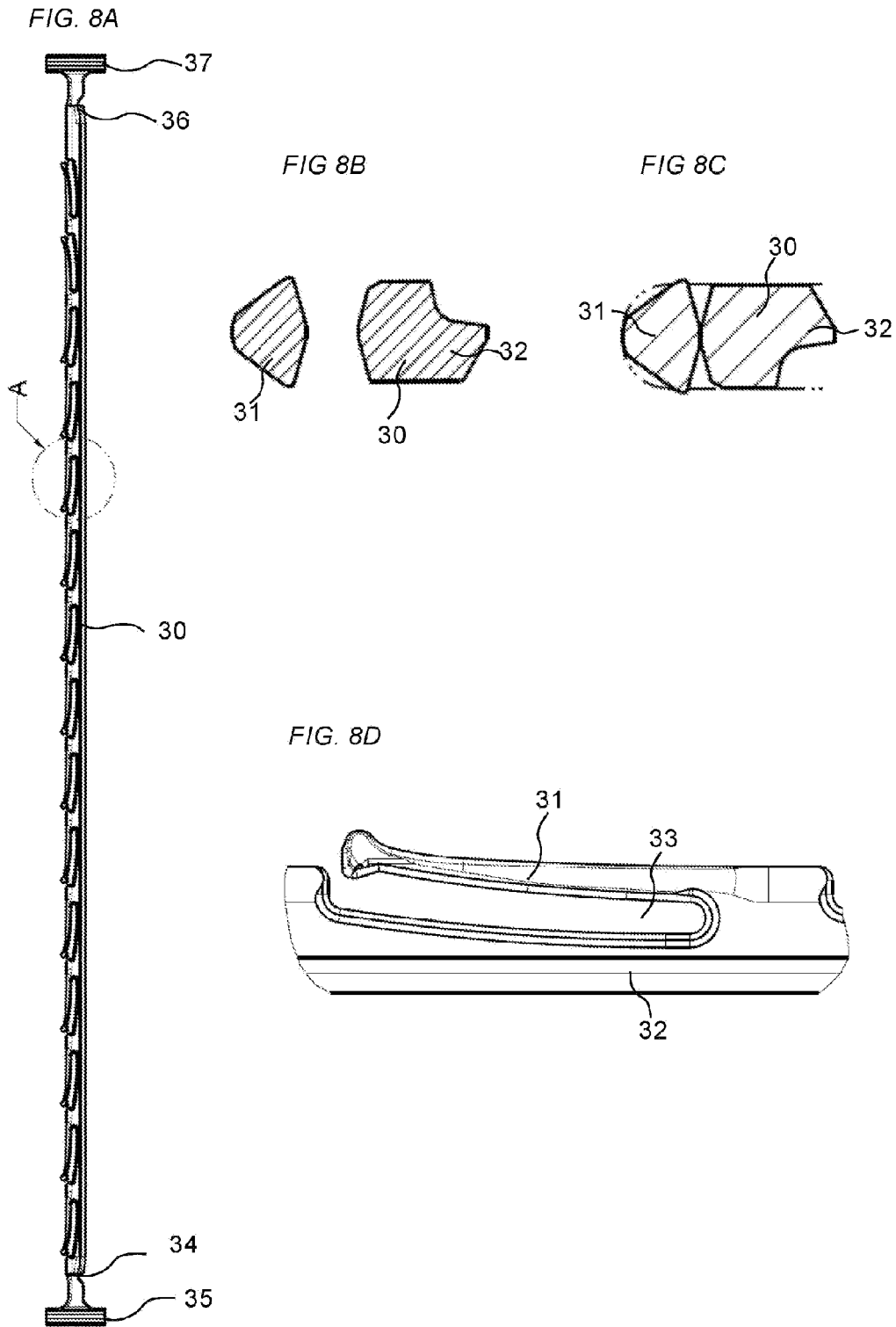

FIG 9A

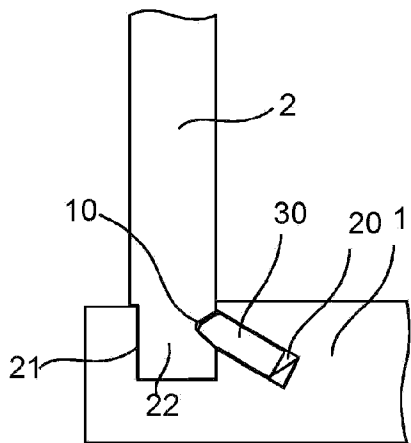

FIG 9B

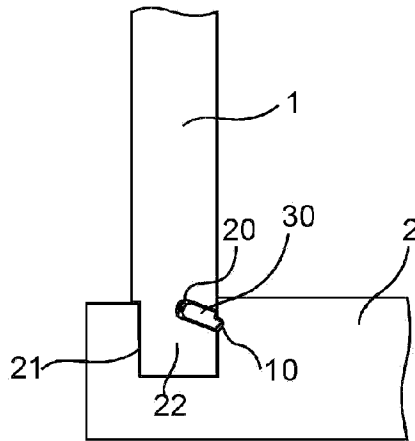

FIG 9C

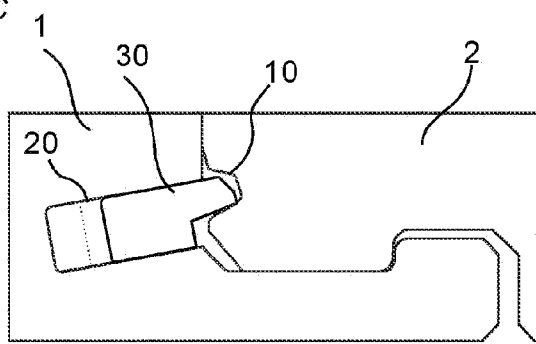

FIG 9D

