

(19) World Intellectual Property Organization
International Bureau



(43) International Publication Date
23 February 2006 (23.02.2006)

PCT

(10) International Publication Number
WO 2006/020827 A2

(51) International Patent Classification:
E21B 19/16 (2006.01)

(21) International Application Number:
PCT/US2005/028669

(22) International Filing Date: 11 August 2005 (11.08.2005)

(25) Filing Language: English

(26) Publication Language: English

(30) Priority Data:
60/600,679 11 August 2004 (11.08.2004) US

(71) Applicants and

(72) Inventors: **BRISCO, David, Paul** [US/US]; 405 Westridge Drive, Duncan, OK 73533 (US). **WATSON, Brock, Wayne** [US/US]; 2535 Marsh Lane, # 1004, Carrollton, TX 75006 (US). **SHUSTER, Mark** [US/US]; 19115 Prospect Lane, Houston, TX 77094 (US). **GRAY, Malcolm** [US/US]; 1502 Wagon Gap Trail, Houston, TX 77010 (US). **GRINBERG, Grigoriy** [US/US]; 4758 Mount Airy, Sylvania, OH 43560 (US). **COSTA, Scott** [US/US]; 25614 Broadcrest Court, Katy, TX 77494 (US). **WASSON, Russell** [US/US]; 2647 Highway J, Bourbon, MO 65441 (US).

(74) Agents: **HAYNES AND BOONE LLP** et al.; 901 Main Street, Suite 3100, Dallas, TX 75202 (US).

(81) Designated States (*unless otherwise indicated, for every kind of national protection available*): AE, AG, AL, AM, AT, AU, AZ, BA, BB, BG, BR, BW, BY, BZ, CA, CH, CN, CO, CR, CU, CZ, DE, DK, DM, DZ, EC, EE, EG, ES, FI, GB, GD, GE, GH, GM, HR, HU, ID, IL, IN, IS, JP, KE,

[Continued on next page]

(71) Applicant (*for all designated States except US*): **EN-VENTURE GLOBAL TECHNOLOGY, LLC** [US/US]; 16200 A Park Row, Houston, TX 77084 (US).

(54) Title: HYDROFORMING METHOD AND APPARATUS

(57) Abstract: A hydroforming method and apparatus.

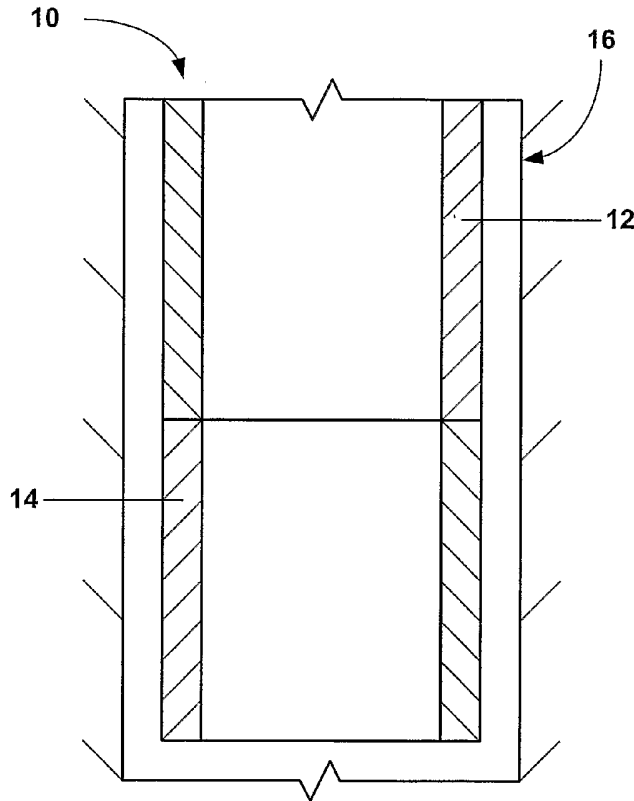

WO 2006/020827 A2



KG, KM, KP, KR, KZ, LC, LK, LR, LS, LT, LU, LV, MA, MD, MG, MK, MN, MW, MX, MZ, NA, NG, NI, NO, NZ, OM, PG, PH, PL, PT, RO, RU, SC, SD, SE, SG, SK, SL, SM, SY, TJ, TM, TN, TR, TT, TZ, UA, UG, US, UZ, VC, VN, YU, ZA, ZM, ZW.

RO, SE, SI, SK, TR), OAPI (BF, BJ, CF, CG, CI, CM, GA, GN, GQ, GW, ML, MR, NE, SN, TD, TG).

Declaration under Rule 4.17:

— *of inventorship (Rule 4.17(iv)) for US only*

Published:

— *without international search report and to be republished upon receipt of that report*

(84) Designated States (*unless otherwise indicated, for every kind of regional protection available*): ARIPO (BW, GH, GM, KE, LS, MW, MZ, NA, SD, SL, SZ, TZ, UG, ZM, ZW), Eurasian (AM, AZ, BY, KG, KZ, MD, RU, TJ, TM), European (AT, BE, BG, CH, CY, CZ, DE, DK, EE, ES, FI, FR, GB, GR, HU, IE, IS, IT, LT, LU, LV, MC, NL, PL, PT,

For two-letter codes and other abbreviations, refer to the "Guidance Notes on Codes and Abbreviations" appearing at the beginning of each regular issue of the PCT Gazette.

HYDROFORMING METHOD AND APPARATUS

Cross Reference To Related Applications

[001] This application claims the benefit of the filing date of US provisional patent application serial number 60/600,679, attorney docket number 25791.194, filed on August 11, 2004, the disclosure which is incorporated herein by reference.

[002] This application is a continuation-in-part of one or more of the following: (1) PCT application US02/04353, filed on 2/14/02, attorney docket no. 25791.50.02, which claims priority from U.S. provisional patent application serial no. 60/270,007, attorney docket no. 25791.50, filed on 2/20/2001; (2) PCT application US 03/00609, filed on 1/9/03, attorney docket no. 25791.71.02, which claims priority from U.S. provisional patent application serial no. 60/357,372, attorney docket no. 25791.71, filed on 2/15/02; and (3) U.S. provisional patent application serial number 60/585,370, attorney docket number 25791.299, filed on 7/2/2004, the disclosures of which are incorporated herein by reference.

[003] This application is related to the following co-pending applications: (1) U.S. Patent Number 6,497,289, which was filed as U.S. Patent Application serial no. 09/454,139, attorney docket no. 25791.03.02, filed on 12/3/1999, which claims priority from provisional application 60/111,293, filed on 12/7/98, (2) U.S. patent application serial no. 09/510,913, attorney docket no. 25791.7.02, filed on 2/23/2000, which claims priority from provisional application 60/121,702, filed on 2/25/99, (3) U.S. patent application serial no. 09/502,350, attorney docket no. 25791.8.02, filed on 2/10/2000, which claims priority from provisional application 60/119,611, filed on 2/11/99, (4) U.S. patent no. 6,328,113, which was filed as U.S. Patent Application serial number 09/440,338, attorney docket number 25791.9.02, filed on 11/15/99, which claims priority from provisional application 60/108,558, filed on 11/16/98, (5) U.S. patent application serial no. 10/169,434, attorney docket no. 25791.10.04, filed on 7/1/02, which claims priority from provisional application 60/183,546, filed on 2/18/00, (6) U.S. patent application serial no. 09/523,468, attorney docket no. 25791.11.02, filed on 3/10/2000, which claims priority from provisional application 60/124,042, filed on 3/11/99, (7) U.S. patent number 6,568,471, which was filed as patent application serial no. 09/512,895, attorney docket no. 25791.12.02, filed on 2/24/2000, which claims priority from provisional application 60/121,841, filed on 2/26/99, (8) U.S. patent number 6,575,240, which was filed as patent application serial no. 09/511,941, attorney docket no. 25791.16.02, filed on 2/24/2000, which claims priority from provisional application 60/121,907, filed on 2/26/99, (9) U.S. patent number 6,557,640, which was filed as patent application serial no. 09/588,946, attorney docket no. 25791.17.02, filed on 6/7/2000, which claims priority from provisional application 60/137,998, filed on 6/7/99, (10) U.S. patent application serial no. 09/981,916, attorney docket no. 25791.18, filed on 10/18/01 as a continuation-in-part application of U.S.

patent no. 6,328,113, which was filed as U.S. Patent Application serial number 09/440,338, attorney docket number 25791.9.02, filed on 11/15/99, which claims priority from provisional application 60/108,558, filed on 11/16/98, (11) U.S. patent number 6,604,763, which was filed as application serial no. 09/559,122, attorney docket no. 25791.23.02, filed on 4/26/2000, which claims priority from provisional application 60/131,106, filed on 4/26/99, (12) U.S. patent application serial no. 10/030,593, attorney docket no. 25791.25.08, filed on 1/8/02, which claims priority from provisional application 60/146,203, filed on 7/29/99, (13) U.S. provisional patent application serial no. 60/143,039, attorney docket no. 25791.26, filed on 7/9/99, (14) U.S. patent application serial no. 10/111,982, attorney docket no. 25791.27.08, filed on 4/30/02, which claims priority from provisional patent application serial no. 60/162,671, attorney docket no. 25791.27, filed on 11/1/1999, (15) U.S. provisional patent application serial no. 60/154,047, attorney docket no. 25791.29, filed on 9/16/1999, (16) U.S. provisional patent application serial no. 60/438,828, attorney docket no. 25791.31, filed on 1/9/03, (17) U.S. patent number 6,564,875, which was filed as application serial no. 09/679,907, attorney docket no. 25791.34.02, on 10/5/00, which claims priority from provisional patent application serial no. 60/159,082, attorney docket no. 25791.34, filed on 10/12/1999, (18) U.S. patent application serial no. 10/089,419, filed on 3/27/02, attorney docket no. 25791.36.03, which claims priority from provisional patent application serial no. 60/159,039, attorney docket no. 25791.36, filed on 10/12/1999, (19) U.S. patent application serial no. 09/679,906, filed on 10/5/00, attorney docket no. 25791.37.02, which claims priority from provisional patent application serial no. 60/159,033, attorney docket no. 25791.37, filed on 10/12/1999, (20) U.S. patent application serial no. 10/303,992, filed on 11/22/02, attorney docket no. 25791.38.07, which claims priority from provisional patent application serial no. 60/212,359, attorney docket no. 25791.38, filed on 6/19/2000, (21) U.S. provisional patent application serial no. 60/165,228, attorney docket no. 25791.39, filed on 11/12/1999, (22) U.S. provisional patent application serial no. 60/455,051, attorney docket no. 25791.40, filed on 3/14/03, (23) PCT application US02/2477, filed on 6/26/02, attorney docket no. 25791.44.02, which claims priority from U.S. provisional patent application serial no. 60/303,711, attorney docket no. 25791.44, filed on 7/6/01, (24) U.S. patent application serial no. 10/311,412, filed on 12/12/02, attorney docket no. 25791.45.07, which claims priority from provisional patent application serial no. 60/221,443, attorney docket no. 25791.45, filed on 7/28/2000, (25) U.S. patent application serial no. 10/, filed on 12/18/02, attorney docket no. 25791.46.07, which claims priority from provisional patent application serial no. 60/221,645, attorney docket no. 25791.46, filed on 7/28/2000, (26) U.S. patent application serial no. 10/322,947, filed on 1/22/03, attorney docket no. 25791.47.03, which claims priority from provisional patent application serial no. 60/233,638, attorney docket no. 25791.47, filed on 9/18/2000, (27) U.S. patent application serial no. 10/406,648, filed on

3/31/03, attorney docket no. 25791.48.06, which claims priority from provisional patent application serial no. 60/237,334, attorney docket no. 25791.48, filed on 10/2/2000, (28) PCT application US02/04353, filed on 2/14/02, attorney docket no. 25791.50.02, which claims priority from U.S. provisional patent application serial no. 60/270,007, attorney docket no. 25791.50, filed on 2/20/2001, (29) U.S. patent application serial no. 10/465,835, filed on 6/13/03, attorney docket no. 25791.51.06, which claims priority from provisional patent application serial no. 60/262,434, attorney docket no. 25791.51, filed on 1/17/2001, (30) U.S. patent application serial no. 10/465,831, filed on 6/13/03, attorney docket no. 25791.52.06, which claims priority from U.S. provisional patent application serial no. 60/259,486, attorney docket no. 25791.52, filed on 1/3/2001, (31) U.S. provisional patent application serial no. 60/452,303, filed on 3/5/03, attorney docket no. 25791.53, (32) U.S. patent number 6,470,966, which was filed as patent application serial number 09/850,093, filed on 5/7/01, attorney docket no. 25791.55, as a divisional application of U.S. Patent Number 6,497,289, which was filed as U.S. Patent Application serial no. 09/454,139, attorney docket no. 25791.03.02, filed on 12/3/1999, which claims priority from provisional application 60/111,293, filed on 12/7/98, (33) U.S. patent number 6,561,227, which was filed as patent application serial number 09/852,026, filed on 5/9/01, attorney docket no. 25791.56, as a divisional application of U.S. Patent Number 6,497,289, which was filed as U.S. Patent Application serial no. 09/454,139, attorney docket no. 25791.03.02, filed on 12/3/1999, which claims priority from provisional application 60/111,293, filed on 12/7/98, (34) U.S. patent application serial number 09/852,027, filed on 5/9/01, attorney docket no. 25791.57, as a divisional application of U.S. Patent Number 6,497,289, which was filed as U.S. Patent Application serial no. 09/454,139, attorney docket no. 25791.03.02, filed on 12/3/1999, which claims priority from provisional application 60/111,293, filed on 12/7/98, (35) PCT Application US02/25608, attorney docket no. 25791.58.02, filed on 8/13/02, which claims priority from provisional application 60/318,021, filed on 9/7/01, attorney docket no. 25791.58, (36) PCT Application US02/24399, attorney docket no. 25791.59.02, filed on 8/1/02, which claims priority from U.S. provisional patent application serial no. 60/313,453, attorney docket no. 25791.59, filed on 8/20/2001, (37) PCT Application US02/29856, attorney docket no. 25791.60.02, filed on 9/19/02, which claims priority from U.S. provisional patent application serial no. 60/326,886, attorney docket no. 25791.60, filed on 10/3/2001, (38) PCT Application US02/20256, attorney docket no. 25791.61.02, filed on 6/26/02, which claims priority from U.S. provisional patent application serial no. 60/303,740, attorney docket no. 25791.61, filed on 7/6/2001, (39) U.S. patent application serial no. 09/962,469, filed on 9/25/01, attorney docket no. 25791.62, which is a divisional of U.S. patent application serial no. 09/523,468, attorney docket no. 25791.11.02, filed on 3/10/2000, which claims priority from provisional application 60/124,042, filed on 3/11/99, (40) U.S. patent application serial

no. 09/962,470, filed on 9/25/01, attorney docket no. 25791.63, which is a divisional of U.S. patent application serial no. 09/523,468, attorney docket no. 25791.11.02, filed on 3/10/2000, which claims priority from provisional application 60/124,042, filed on 3/11/99, (41) U.S. patent application serial no. 09/962,471, filed on 9/25/01, attorney docket no. 25791.64, which is a divisional of U.S. patent application serial no. 09/523,468, attorney docket no. 25791.11.02, filed on 3/10/2000, which claims priority from provisional application 60/124,042, filed on 3/11/99, (42) U.S. patent application serial no. 09/962,467, filed on 9/25/01, attorney docket no. 25791.65, which is a divisional of U.S. patent application serial no. 09/523,468, attorney docket no. 25791.11.02, filed on 3/10/2000, which claims priority from provisional application 60/124,042, filed on 3/11/99, (43) U.S. patent application serial no. 09/962,468, filed on 9/25/01, attorney docket no. 25791.66, which is a divisional of U.S. patent application serial no. 09/523,468, attorney docket no. 25791.11.02, filed on 3/10/2000, which claims priority from provisional application 60/124,042, filed on 3/11/99, (44) PCT application US 02/25727, filed on 8/14/02, attorney docket no. 25791.67.03, which claims priority from U.S. provisional patent application serial no. 60/317,985, attorney docket no. 25791.67, filed on 9/6/2001, and U.S. provisional patent application serial no. 60/318,386, attorney docket no. 25791.67.02, filed on 9/10/2001, (45) PCT application US 02/39425, filed on 12/10/02, attorney docket no. 25791.68.02, which claims priority from U.S. provisional patent application serial no. 60/343,674, attorney docket no. 25791.68, filed on 12/27/2001, (46) U.S. utility patent application serial no. 09/969,922, attorney docket no. 25791.69, filed on 10/3/2001, which is a continuation-in-part application of U.S. patent no. 6,328,113, which was filed as U.S. Patent Application serial number 09/440,338, attorney docket number 25791.9.02, filed on 11/15/99, which claims priority from provisional application 60/108,558, filed on 11/16/98, (47) U.S. utility patent application serial no. 10/516,467, attorney docket no. 25791.70, filed on 12/10/01, which is a continuation application of U.S. utility patent application serial no. 09/969,922, attorney docket no. 25791.69, filed on 10/3/2001, which is a continuation-in-part application of U.S. patent no. 6,328,113, which was filed as U.S. Patent Application serial number 09/440,338, attorney docket number 25791.9.02, filed on 11/15/99, which claims priority from provisional application 60/108,558, filed on 11/16/98, (48) PCT application US 03/00609, filed on 1/9/03, attorney docket no. 25791.71.02, which claims priority from U.S. provisional patent application serial no. 60/357,372, attorney docket no. 25791.71, filed on 2/15/02, (49) U.S. patent application serial no. 10/074,703, attorney docket no. 25791.74, filed on 2/12/02, which is a divisional of U.S. patent number 6,568,471, which was filed as patent application serial no. 09/512,895, attorney docket no. 25791.12.02, filed on 2/24/2000, which claims priority from provisional application 60/121,841, filed on 2/26/99, (50) U.S. patent application serial no. 10/074,244, attorney docket no. 25791.75, filed on 2/12/02, which is a divisional of

U.S. patent number 6,568,471, which was filed as patent application serial no. 09/512,895, attorney docket no. 25791.12.02, filed on 2/24/2000, which claims priority from provisional application 60/121,841, filed on 2/26/99, (51) U.S. patent application serial no. 10/076,660, attorney docket no. 25791.76, filed on 2/15/02, which is a divisional of U.S. patent number 6,568,471, which was filed as patent application serial no. 09/512,895, attorney docket no. 25791.12.02, filed on 2/24/2000, which claims priority from provisional application 60/121,841, filed on 2/26/99, (52) U.S. patent application serial no. 10/076,661, attorney docket no. 25791.77, filed on 2/15/02, which is a divisional of U.S. patent number 6,568,471, which was filed as patent application serial no. 09/512,895, attorney docket no. 25791.12.02, filed on 2/24/2000, which claims priority from provisional application 60/121,841, filed on 2/26/99, (53) U.S. patent application serial no. 10/076,659, attorney docket no. 25791.78, filed on 2/15/02, which is a divisional of U.S. patent number 6,568,471, which was filed as patent application serial no. 09/512,895, attorney docket no. 25791.12.02, filed on 2/24/2000, which claims priority from provisional application 60/121,841, filed on 2/26/99, (54) U.S. patent application serial no. 10/078,928, attorney docket no. 25791.79, filed on 2/20/02, which is a divisional of U.S. patent number 6,568,471, which was filed as patent application serial no. 09/512,895, attorney docket no. 25791.12.02, filed on 2/24/2000, which claims priority from provisional application 60/121,841, filed on 2/26/99, (55) U.S. patent application serial no. 10/078,922, attorney docket no. 25791.80, filed on 2/20/02, which is a divisional of U.S. patent number 6,568,471, which was filed as patent application serial no. 09/512,895, attorney docket no. 25791.12.02, filed on 2/24/2000, which claims priority from provisional application 60/121,841, filed on 2/26/99, (56) U.S. patent application serial no. 10/078,921, attorney docket no. 25791.81, filed on 2/20/02, which is a divisional of U.S. patent number 6,568,471, which was filed as patent application serial no. 09/512,895, attorney docket no. 25791.12.02, filed on 2/24/2000, which claims priority from provisional application 60/121,841, filed on 2/26/99, (57) U.S. patent application serial no. 10/261,928, attorney docket no. 25791.82, filed on 10/1/02, which is a divisional of U.S. patent number 6,557,640, which was filed as patent application serial no. 09/588,946, attorney docket no. 25791.17.02, filed on 6/7/2000, which claims priority from provisional application 60/137,998, filed on 6/7/99, (58) U.S. patent application serial no. 10/079,276 , attorney docket no. 25791.83, filed on 2/20/02, which is a divisional of U.S. patent number 6,568,471, which was filed as patent application serial no. 09/512,895, attorney docket no. 25791.12.02, filed on 2/24/2000, which claims priority from provisional application 60/121,841, filed on 2/26/99, (59) U.S. patent application serial no. 10/262,009, attorney docket no. 25791.84, filed on 10/1/02, which is a divisional of U.S. patent number 6,557,640, which was filed as patent application serial no. 09/588,946, attorney docket no. 25791.17.02, filed on 6/7/2000, which

claims priority from provisional application 60/137,998, filed on 6/7/99, (60) U.S. patent application serial no. 10/092,481, attorney docket no. 25791.85, filed on 3/7/02, which is a divisional of U.S. patent number 6,568,471, which was filed as patent application serial no. 09/512,895, attorney docket no. 25791.12.02, filed on 2/24/2000, which claims priority from provisional application 60/121,841, filed on 2/26/99, (61) U.S. patent application serial no. 10/261,926, attorney docket no. 25791.86, filed on 10/1/02, which is a divisional of U.S. patent number 6,557,640, which was filed as patent application serial no. 09/588,946, attorney docket no. 25791.17.02, filed on 6/7/2000, which claims priority from provisional application 60/137,998, filed on 6/7/99, (62) PCT application US 02/36157, filed on 11/12/02, attorney docket no. 25791.87.02, which claims priority from U.S. provisional patent application serial no. 60/338,996, attorney docket no. 25791.87, filed on 11/12/01, (63) PCT application US 02/36267, filed on 11/12/02, attorney docket no. 25791.88.02, which claims priority from U.S. provisional patent application serial no. 60/339,013, attorney docket no. 25791.88, filed on 11/12/01, (64) PCT application US 03/11765, filed on 4/16/03, attorney docket no. 25791.89.02, which claims priority from U.S. provisional patent application serial no. 60/383,917, attorney docket no. 25791.89, filed on 5/29/02, (65) PCT application US 03/15020, filed on 5/12/03, attorney docket no. 25791.90.02, which claims priority from U.S. provisional patent application serial no. 60/391,703, attorney docket no. 25791.90, filed on 6/26/02, (66) PCT application US 02/39418, filed on 12/10/02, attorney docket no. 25791.92.02, which claims priority from U.S. provisional patent application serial no. 60/346,309, attorney docket no. 25791.92, filed on 1/7/02, (67) PCT application US 03/06544, filed on 3/4/03, attorney docket no. 25791.93.02, which claims priority from U.S. provisional patent application serial no. 60/372,048, attorney docket no. 25791.93, filed on 4/12/02, (68) U.S. patent application serial no. 10/331,718, attorney docket no. 25791.94, filed on 12/30/02, which is a divisional U.S. patent application serial no. 09/679,906, filed on 10/5/00, attorney docket no. 25791.37.02, which claims priority from provisional patent application serial no. 60/159,033, attorney docket no. 25791.37, filed on 10/12/1999, (69) PCT application US 03/04837, filed on 2/29/03, attorney docket no. 25791.95.02, which claims priority from U.S. provisional patent application serial no. 60/363,829, attorney docket no. 25791.95, filed on 3/13/02, (70) U.S. patent application serial no. 10/261,927, attorney docket no. 25791.97, filed on 10/1/02, which is a divisional of U.S. patent number 6,557,640, which was filed as patent application serial no. 09/588,946, attorney docket no. 25791.17.02, filed on 6/7/2000, which claims priority from provisional application 60/137,998, filed on 6/7/99, (71) U.S. patent application serial no. 10/262,008, attorney docket no. 25791.98, filed on 10/1/02, which is a divisional of U.S. patent number 6,557,640, which was filed as patent application serial no. 09/588,946, attorney docket no. 25791.17.02, filed on 6/7/2000, which claims priority from provisional application 60/137,998, filed on 6/7/99, (72)

U.S. patent application serial no. 10/261,925, attorney docket no. 25791.99, filed on 10/1/02, which is a divisional of U.S. patent number 6,557,640, which was filed as patent application serial no. 09/588,946, attorney docket no. 25791.17.02, filed on 6/7/2000, which claims priority from provisional application 60/137,998, filed on 6/7/99, (73) U.S. patent application serial no. 10/199,524, attorney docket no. 25791.100, filed on 7/19/02, which is a continuation of U.S. Patent Number 6,497,289, which was filed as U.S. Patent Application serial no. 09/454,139, attorney docket no. 25791.03.02, filed on 12/3/1999, which claims priority from provisional application 60/111,293, filed on 12/7/98, (74) PCT application US 03/10144, filed on 3/28/03, attorney docket no. 25791.101.02, which claims priority from U.S. provisional patent application serial no. 60/372,632, attorney docket no. 25791.101, filed on 4/15/02, (75) U.S. provisional patent application serial no. 60/412,542, attorney docket no. 25791.102, filed on 9/20/02, (76) PCT application US 03/14153, filed on 5/6/03, attorney docket no. 25791.104.02, which claims priority from U.S. provisional patent application serial no. 60/380,147, attorney docket no. 25791.104, filed on 5/6/02, (77) PCT application US 03/19993, filed on 6/24/03, attorney docket no. 25791.106.02, which claims priority from U.S. provisional patent application serial no. 60/397,284, attorney docket no. 25791.106, filed on 7/19/02, (78) PCT application US 03/13787, filed on 5/5/03, attorney docket no. 25791.107.02, which claims priority from U.S. provisional patent application serial no. 60/387,486, attorney docket no. 25791.107, filed on 6/10/02, (79) PCT application US 03/18530, filed on 6/11/03, attorney docket no. 25791.108.02, which claims priority from U.S. provisional patent application serial no. 60/387,961, attorney docket no. 25791.108, filed on 6/12/02, (80) PCT application US 03/20694, filed on 7/1/03, attorney docket no. 25791.110.02, which claims priority from U.S. provisional patent application serial no. 60/398,061, attorney docket no. 25791.110, filed on 7/24/02, (81) PCT application US 03/20870, filed on 7/2/03, attorney docket no. 25791.111.02, which claims priority from U.S. provisional patent application serial no. 60/399,240, attorney docket no. 25791.111, filed on 7/29/02, (82) U.S. provisional patent application serial no. 60/412,487, attorney docket no. 25791.112, filed on 9/20/02, (83) U.S. provisional patent application serial no. 60/412,488, attorney docket no. 25791.114, filed on 9/20/02, (84) U.S. patent application serial no. 10/280,356, attorney docket no. 25791.115, filed on 10/25/02, which is a continuation of U.S. patent number 6,470,966, which was filed as patent application serial number 09/850,093, filed on 5/7/01, attorney docket no. 25791.55, as a divisional application of U.S. Patent Number 6,497,289, which was filed as U.S. Patent Application serial no. 09/454,139, attorney docket no. 25791.03.02, filed on 12/3/1999, which claims priority from provisional application 60/111,293, filed on 12/7/98, (85) U.S. provisional patent application serial no. 60/412,177, attorney docket no. 25791.117, filed on 9/20/02, (86) U.S. provisional patent application serial no. 60/412,653, attorney docket no. 25791.118, filed on 9/20/02, (87) U.S.

provisional patent application serial no. 60/405,610, attorney docket no. 25791.119, filed on 8/23/02, (88) U.S. provisional patent application serial no. 60/405,394, attorney docket no. 25791.120, filed on 8/23/02, (89) U.S. provisional patent application serial no. 60/412,544, attorney docket no. 25791.121, filed on 9/20/02, (90) PCT application US 03/24779, filed on 8/8/03, attorney docket no. 25791.125.02, which claims priority from U.S. provisional patent application serial no. 60/407,442, attorney docket no. 25791.125, filed on 8/30/02, (91) U.S. provisional patent application serial no. 60/423,363, attorney docket no. 25791.126, filed on 12/10/02, (92) U.S. provisional patent application serial no. 60/412,196, attorney docket no. 25791.127, filed on 9/20/02, (93) U.S. provisional patent application serial no. 60/412,187, attorney docket no. 25791.128, filed on 9/20/02, (94) U.S. provisional patent application serial no. 60/412,371, attorney docket no. 25791.129, filed on 9/20/02, (95) U.S. patent application serial no. 10/382,325, attorney docket no. 25791.145, filed on 3/5/03, which is a continuation of U.S. patent number 6,557,640, which was filed as patent application serial no. 09/588,946, attorney docket no. 25791.17.02, filed on 6/7/2000, which claims priority from provisional application 60/137,998, filed on 6/7/99, (96) U.S. patent application serial no. 10/624,842, attorney docket no. 25791.151, filed on 7/22/03, which is a divisional of U.S. patent application serial no. 09/502,350, attorney docket no. 25791.8.02, filed on 2/10/2000, which claims priority from provisional application 60/119,611, filed on 2/11/99, (97) U.S. provisional patent application serial no. 60/431,184, attorney docket no. 25791.157, filed on 12/5/02, (98) U.S. provisional patent application serial no. 60/448,526, attorney docket no. 25791.185, filed on 2/18/03, (99) U.S. provisional patent application serial no. 60/461,539, attorney docket no. 25791.186, filed on 4/9/03, (100) U.S. provisional patent application serial no. 60/462,750, attorney docket no. 25791.193, filed on 4/14/03, (101) U.S. provisional patent application serial no. 60/436,106, attorney docket no. 25791.200, filed on 12/23/02, (102) U.S. provisional patent application serial no. 60/442,942, attorney docket no. 25791.213, filed on 1/27/03, (103) U.S. provisional patent application serial no. 60/442,938, attorney docket no. 25791.225, filed on 1/27/03, (104) U.S. provisional patent application serial no. 60/418,687, attorney docket no. 25791.228, filed on 4/18/03, (105) U.S. provisional patent application serial no. 60/454,896, attorney docket no. 25791.236, filed on 3/14/03, (106) U.S. provisional patent application serial no. 60/450,504, attorney docket no. 25791.238, filed on 2/26/03, (107) U.S. provisional patent application serial no. 60/451,152, attorney docket no. 25791.239, filed on 3/9/03, (108) U.S. provisional patent application serial no. 60/455,124, attorney docket no. 25791.241, filed on 3/17/03, (109) U.S. provisional patent application serial no. 60/453,678, attorney docket no. 25791.253, filed on 3/11/03, (110) U.S. patent application serial no. 10/421,682, attorney docket no. 25791.256, filed on 4/23/03, which is a continuation of U.S. patent application serial no. 09/523,468, attorney docket no. 25791.11.02, filed on 3/10/2000, which claims

priority from provisional application 60/124,042, filed on 3/11/99, (111) U.S. provisional patent application serial no. 60/457,965, attorney docket no. 25791.260, filed on 3/27/03, (112) U.S. provisional patent application serial no. 60/455,718, attorney docket no. 25791.262, filed on 3/18/03, (113) U.S. patent number 6,550,821, which was filed as patent application serial no. 09/811,734, filed on 3/19/01, (114) U.S. patent application serial no. 10/436,467, attorney docket no. 25791.268, filed on 5/12/03, which is a continuation of U.S. patent number 6,604,763, which was filed as application serial no. 09/559,122, attorney docket no. 25791.23.02, filed on 4/26/2000, which claims priority from provisional application 60/131,106, filed on 4/26/99, (115) U.S. provisional patent application serial no. 60/459,776, attorney docket no. 25791.270, filed on 4/2/03, (116) U.S. provisional patent application serial no. 60/461,094, attorney docket no. 25791.272, filed on 4/8/03, (117) U.S. provisional patent application serial no. 60/461,038, attorney docket no. 25791.273, filed on 4/7/03, (118) U.S. provisional patent application serial no. 60/463,586, attorney docket no. 25791.277, filed on 4/17/03, (119) U.S. provisional patent application serial no. 60/472,240, attorney docket no. 25791.286, filed on 5/20/03, (120) U.S. patent application serial no. 10/619,285, attorney docket no. 25791.292, filed on 7/14/03, which is a continuation-in-part of U.S. utility patent application serial no. 09/969,922, attorney docket no. 25791.69, filed on 10/3/2001, which is a continuation-in-part application of U.S. patent no. 6,328,113, which was filed as U.S. Patent Application serial number 09/440,338, attorney docket number 25791.9.02, filed on 11/15/99, which claims priority from provisional application 60/108,558, filed on 11/16/98, (121) U.S. utility patent application serial no. 10/418,688, attorney docket no. 25791.257, which was filed on 4/18/03, as a division of U.S. utility patent application serial no. 09/523,468, attorney docket no. 25791.11.02, filed on 3/10/2000, which claims priority from provisional application 60/124,042, filed on 3/11/99, (122) PCT patent application serial no. PCT/US04/06246, attorney docket no. 25791.238.02, filed on 2/26/2004, (123) PCT patent application serial number PCT/US04/08170, attorney docket number 25791.40.02, filed on 3/15/04, (124) PCT patent application serial number PCT/US04/08171, attorney docket number 25791.236.02, filed on 3/15/04, (125) PCT patent application serial number PCT/US04/08073, attorney docket number 25791.262.02, filed on 3/18/04, (126) PCT patent application serial number PCT/US04/07711, attorney docket number 25791.253.02, filed on 3/11/2004, (127) PCT patent application serial number PCT/US2004/009434, attorney docket number 25791.260.02, filed on 3/26/2004, (128) PCT patent application serial number PCT/US2004/010317, attorney docket number 25791.270.02, filed on 4/2/2004, (129) PCT patent application serial number PCT/US2004/010712, attorney docket number 25791.272.02, filed on 4/6/2004, (130) PCT patent application serial number PCT/US2004/010762, attorney docket number 25791.273.02, filed on 4/6/2004, (131) PCT patent application serial number

PCT/2004/011973, attorney docket number 25791.277.02, filed on 4/15/2004, (132) U.S. provisional patent application serial number 60/495,056, attorney docket number 25791.301, filed on 8/14/2003, and (133) U.S. provisional patent application serial number 60/585,370, attorney docket number 25791.299, filed on 7/2/2004, the disclosures of which are incorporated herein by reference.

Background of the Invention

[004] This invention relates generally to oil and gas exploration, and in particular to forming and repairing wellbore casings to facilitate oil and gas exploration.

Summary Of The Invention

[005] According to one aspect of the present invention, a method of radially expanding a tubular assembly is provided that includes radially expanding and plastically deforming a lower portion of the tubular assembly by pressurizing the interior of the lower portion of the tubular assembly; and then, radially expanding and plastically deforming the remaining portion of the tubular assembly by contacting the interior of the tubular assembly with an expansion device.

[006] According to another aspect of the present invention, a system for radially expanding a tubular assembly is provided that includes means for radially expanding and plastically deforming a lower portion of the tubular assembly by pressurizing the interior of the lower portion of the tubular assembly; and then, means for radially expanding and plastically deforming the remaining portion of the tubular assembly by contacting the interior of the tubular assembly with an expansion device.

[007] According to another aspect of the present invention, a method of repairing a tubular assembly is provided that includes positioning a tubular patch within the tubular assembly; and radially expanding and plastically deforming a tubular patch into engagement with the tubular assembly by pressurizing the interior of the tubular patch.

[008] According to another aspect of the present invention, a system for repairing a tubular assembly is provided that includes means for positioning a tubular patch within the tubular assembly; and means for radially expanding and plastically deforming a tubular patch into engagement with the tubular assembly by pressurizing the interior of the tubular patch.

[009] According to another aspect of the present invention, a method of radially expanding a tubular member is provided that includes accumulating a supply of pressurized fluid; and controllably injecting the pressurized fluid into the interior of the tubular member.

[0010] According to another aspect of the present invention, a system for radially expanding a tubular member is provided that includes means for accumulating a supply of pressurized fluid; and means for controllably injecting the pressurized fluid into the interior of the tubular member.

[0011] According to another aspect of the present invention, an apparatus for radially expanding a tubular member is provided that includes a fluid reservoir; a pump for pumping fluids out of the fluid reservoir; an accumulator for receiving and accumulating the fluids pumped from the reservoir; a flow control valve for controllably releasing the fluids accumulated within the reservoir; and an expansion element for engaging the interior of the tubular member to define a pressure chamber within the tubular member and receiving the released accumulated fluids into the pressure chamber.

[0012] According to another aspect of the present invention, a method for radially expanding a tubular member is provided that includes positioning a tubular member and an adjustable expansion device within a preexisting structure; radially expanding and plastically deforming at least a portion of the tubular member by pressurizing an interior portion of the tubular member; increasing the size of the adjustable expansion device; and radially expanding and plastically deforming another portion of the tubular member by displacing the adjustable expansion device relative to the tubular member.

[0013] According to another aspect of the present invention, a system for radially expanding a tubular member is provided that includes means for positioning a tubular member and an adjustable expansion device within a preexisting structure; means for radially expanding and plastically deforming at least a portion of the tubular member by pressurizing an interior portion of the tubular member; means for increasing the size of the adjustable expansion device; and means for radially expanding and plastically deforming another portion of the tubular member by displacing the adjustable expansion device relative to the tubular member.

[0014] According to another aspect of the present invention, an apparatus for radially expanding a tubular member is provided that includes: an expandable tubular member; an expansion device coupled to the expandable tubular member for radially expanding and plastically deforming the expandable tubular member; an tubular expansion limiter coupled to the expandable tubular member for limiting the degree to which the expandable tubular member may be radially expanded and plastically deformed; a locking device positioned within the expandable tubular member releasably coupled to the expandable tubular member; a tubular support member positioned within the expandable tubular member coupled to the locking device and the expansion device; means for transmitting torque between the expandable tubular member and the tubular support member; means for sealing the interface between the expandable tubular member and the tubular support member; means for sensing the operating pressure within the tubular support member; and means for pressurizing the interior of the tubular support member; wherein at least a portion of the expandable tubular member has a higher ductility and a lower yield point prior to the

radial expansion and plastic deformation than after the radial expansion and plastic deformation.

[0015] According to another aspect of the present invention, a method for radially expanding a tubular member is provided that includes positioning a tubular member and an adjustable expansion device within a preexisting structure; radially expanding and plastically deforming at least a portion of the tubular member by pressurizing an interior portion of the tubular member; limiting the extent to which the portion of the tubular member is radially expanded and plastically deformed by pressurizing the interior of the tubular member; increasing the size of the adjustable expansion device; and radially expanding and plastically deforming another portion of the tubular member by displacing the adjustable expansion device relative to the tubular member.

[0016] According to another aspect of the present invention, a system for radially expanding a tubular member is provided that includes means for positioning a tubular member and an adjustable expansion device within a preexisting structure; means for radially expanding and plastically deforming at least a portion of the tubular member by pressurizing an interior portion of the tubular member; means for limiting the extent to which the portion of the tubular member is radially expanded and plastically deformed by pressurizing the interior of the tubular member; means for increasing the size of the adjustable expansion device; and means for radially expanding and plastically deforming another portion of the tubular member by displacing the adjustable expansion device relative to the tubular member.

Brief Description of the Drawings

[0017] Fig. 1 is a fragmentary cross sectional view of an exemplary embodiment of an expandable tubular member positioned within a preexisting structure.

[0018] Fig. 2 is a fragmentary cross sectional view of the expandable tubular member of Fig. 1 after positioning an expansion device within the expandable tubular member.

[0019] Fig. 3 is a fragmentary cross sectional view of the expandable tubular member of Fig. 2 after operating the expansion device within the expandable tubular member to radially expand and plastically deform a portion of the expandable tubular member.

[0020] Fig. 4 is a fragmentary cross sectional view of the expandable tubular member of Fig. 3 after operating the expansion device within the expandable tubular member to radially expand and plastically deform another portion of the expandable tubular member.

[0021] Fig. 5 is a graphical illustration of exemplary embodiments of the stress/strain curves for several portions of the expandable tubular member of Figs. 1-4.

[0022] Fig. 6 is a graphical illustration of the an exemplary embodiment of the yield strength vs. ductility curve for at least a portion of the expandable tubular member of Figs. 1-4.

[0023] Fig. 7 is a fragmentary cross sectional illustration of an embodiment of a series of overlapping expandable tubular members.

[0024] Fig. 8 is a fragmentary cross sectional view of an exemplary embodiment of an expandable tubular member positioned within a preexisting structure.

[0025] Fig. 9 is a fragmentary cross sectional view of the expandable tubular member of Fig. 8 after positioning an expansion device within the expandable tubular member.

[0026] Fig. 10 is a fragmentary cross sectional view of the expandable tubular member of Fig. 9 after operating the expansion device within the expandable tubular member to radially expand and plastically deform a portion of the expandable tubular member.

[0027] Fig. 11 is a fragmentary cross sectional view of the expandable tubular member of Fig. 10 after operating the expansion device within the expandable tubular member to radially expand and plastically deform another portion of the expandable tubular member.

[0028] Fig. 12 is a graphical illustration of exemplary embodiments of the stress/strain curves for several portions of the expandable tubular member of Figs. 8-11.

[0029] Fig. 13 is a graphical illustration of an exemplary embodiment of the yield strength vs. ductility curve for at least a portion of the expandable tubular member of Figs. 8-11.

[0030] Fig. 14 is a fragmentary cross sectional view of an exemplary embodiment of an expandable tubular member positioned within a preexisting structure.

[0031] Fig. 15 is a fragmentary cross sectional view of the expandable tubular member of Fig. 14 after positioning an expansion device within the expandable tubular member.

[0032] Fig. 16 is a fragmentary cross sectional view of the expandable tubular member of Fig. 15 after operating the expansion device within the expandable tubular member to radially expand and plastically deform a portion of the expandable tubular member.

[0033] Fig. 17 is a fragmentary cross sectional view of the expandable tubular member of Fig. 16 after operating the expansion device within the expandable tubular member to radially expand and plastically deform another portion of the expandable tubular member.

[0034] Fig. 18 is a flow chart illustration of an exemplary embodiment of a method of processing an expandable tubular member.

[0035] Fig. 19 is a graphical illustration of the an exemplary embodiment of the yield strength vs. ductility curve for at least a portion of the expandable tubular member during the operation of the method of Fig. 18.

[0036] Fig. 20 is a graphical illustration of stress/strain curves for an exemplary embodiment of an expandable tubular member.

[0037] Fig. 21 is a graphical illustration of stress/strain curves for an exemplary embodiment of an expandable tubular member.

[0038] Fig. 35a is a fragmentary cross-sectional illustration of an exemplary embodiment of an expandable tubular member.

[0039] Fig. 35b is a graphical illustration of an exemplary embodiment of the variation in the yield point for the expandable tubular member of Fig. 35a.

[0040] Fig. 36a is a flow chart illustration of an exemplary embodiment of a method for processing a tubular member.

[0041] Fig. 36b is an illustration of the microstructure of an exemplary embodiment of a tubular member prior to thermal processing.

[0042] Fig. 36c is an illustration of the microstructure of an exemplary embodiment of a tubular member after thermal processing.

[0043] Fig. 37a is a flow chart illustration of an exemplary embodiment of a method for processing a tubular member.

[0044] Fig. 37b is an illustration of the microstructure of an exemplary embodiment of a tubular member prior to thermal processing.

[0045] Fig. 37c is an illustration of the microstructure of an exemplary embodiment of a tubular member after thermal processing.

[0046] Fig. 38a is a flow chart illustration of an exemplary embodiment of a method for processing a tubular member.

[0047] Fig. 38b is an illustration of the microstructure of an exemplary embodiment of a tubular member prior to thermal processing.

[0048] Fig. 38c is an illustration of the microstructure of an exemplary embodiment of a tubular member after thermal processing.

[0049] Fig. 39a is a fragmentary cross sectional illustration of an exemplary embodiment of expandable tubular members positioned within a preexisting structure.

[0050] Fig. 39b is a fragmentary cross sectional illustration of the expandable tubular members of Fig. 39a after placing an adjustable expansion device and a hydroforming expansion device within the expandable tubular members.

[0051] Fig. 39c is a fragmentary cross sectional illustration of the expandable tubular members of Fig. 39b after operating the hydroforming expansion device to radially expand and plastically deform at least a portion of the expandable tubular members.

[0052] Fig. 39d is a fragmentary cross sectional illustration of the expandable tubular members of Fig. 39c after operating the hydroforming expansion device to disengage from the expandable tubular members.

[0053] Fig. 39e is a fragmentary cross sectional illustration of the expandable tubular members of Fig. 39d after positioning the adjustable expansion device within the radially expanded portion of the expandable tubular members and then adjusting the size of the adjustable expansion device.

[0054] Fig. 39f is a fragmentary cross sectional illustration of the expandable tubular members of Fig. 39e after operating the adjustable expansion device to radially expand another portion of the expandable tubular members.

[0055] Fig. 40a is a fragmentary cross sectional illustration of an exemplary embodiment of expandable tubular members positioned within a preexisting structure.

[0056] Fig. 40b is a fragmentary cross sectional illustration of the expandable tubular members of Fig. 40a after placing a hydroforming expansion device within a portion of the expandable tubular members.

[0057] Fig. 40c is a fragmentary cross sectional illustration of the expandable tubular members of Fig. 40b after operating the hydroforming expansion device to radially expand and plastically deform at least a portion of the expandable tubular members.

[0058] Fig. 40d is a fragmentary cross sectional illustration of the expandable tubular members of Fig. 40c after placing the hydroforming expansion device within another portion of the expandable tubular members.

[0059] Fig. 40e is a fragmentary cross sectional illustration of the expandable tubular members of Fig. 40d after operating the hydroforming expansion device to radially expand and plastically deform at least another portion of the expandable tubular members.

[0060] Fig. 40f is a fragmentary cross sectional illustration of the expandable tubular members of Fig. 40e after placing the hydroforming expansion device within another portion of the expandable tubular members.

[0061] Fig. 40g is a fragmentary cross sectional illustration of the expandable tubular members of Fig. 40f after operating the hydroforming expansion device to radially expand and plastically deform at least another portion of the expandable tubular members.

[0062] Fig. 41a is a fragmentary cross sectional illustration of an exemplary embodiment of expandable tubular members positioned within a preexisting structure, wherein the bottom most tubular member includes a valveable passageway.

[0063] Fig. 41b is a fragmentary cross sectional illustration of the expandable tubular members of Fig. 41a after placing a hydroforming expansion device within the lower most expandable tubular member.

[0064] Fig. 41c is a fragmentary cross sectional illustration of the expandable tubular members of Fig. 41b after operating the hydroforming expansion device to radially expand and plastically deform at least a portion of the lower most expandable tubular member.

[0065] Fig. 41d is a fragmentary cross sectional illustration of the expandable tubular members of Fig. 41c after disengaging hydroforming expansion device from the lower most expandable tubular member.

[0066] Fig. 41e is a fragmentary cross sectional illustration of the expandable tubular members of Fig. 41d after positioning the adjustable expansion device within the radially expanded and plastically deformed portion of the lower most expandable tubular member.

[0067] Fig. 41f is a fragmentary cross sectional illustration of the expandable tubular members of Fig. 41e after operating the adjustable expansion device to engage the radially expanded and plastically deformed portion of the lower most expandable tubular member.

[0068] Fig. 41g is a fragmentary cross sectional illustration of the expandable tubular members of Fig. 41f after operating the adjustable expansion device to radially expand and plastically deform at least another portion of the expandable tubular members.

[0069] Fig. 41h is a fragmentary cross sectional illustration of the expandable tubular members of Fig. 41g after machining away the lower most portion of the lower most expandable tubular member.

[0070] Fig. 42a is a fragmentary cross sectional illustration of an exemplary embodiment of tubular members positioned within a preexisting structure, wherein one of the tubular members includes one or more radial passages.

[0071] Fig. 42b is a fragmentary cross sectional illustration of the tubular members of Fig. 42a after placing a hydroforming casing patch device within the tubular member having the radial passages.

[0072] Fig. 42c is a fragmentary cross sectional illustration of the tubular members of Fig. 42b after operating the hydroforming expansion device to radially expand and plastically deform a tubular casing patch into engagement with the tubular member having the radial passages.

[0073] Fig. 41d is a fragmentary cross sectional illustration of the expandable tubular members of Fig. 41c after disengaging the hydroforming expansion device from the tubular member having the radial passages.

[0074] Fig. 41e is a fragmentary cross sectional illustration of the expandable tubular members of Fig. 41d after removing the hydroforming expansion device from the tubular member having the radial passages.

[0075] Fig. 43 is a schematic illustration of an exemplary embodiment of a hydroforming expansion device.

[0076] Figs. 44a-44b are flow chart illustrations of an exemplary method of operating the hydroforming expansion device of Fig. 43.

[0077] Fig. 45a is a fragmentary cross sectional illustration of an exemplary embodiment of a radial expansion system positioned within a cased section of a wellbore.

[0078] Fig. 45b is a fragmentary cross sectional illustration of the system of Fig. 45a following the placement of a ball within the throat passage of the system.

[0079] Fig. 45c is a fragmentary cross sectional illustration of the system of Fig. 45b during the injection of fluidic materials to burst the burst disc of the system.

[0080] Fig. 45d is a fragmentary cross sectional illustration of the system of Fig. 45c during the continued injection of fluidic materials to radially expand and plastically deform at least a portion of the tubular liner hanger.

[0081] Fig. 45e is a fragmentary cross sectional illustration of the system of Fig. 45d during the continued injection of fluidic materials to adjust the size of the adjustable expansion device assembly.

[0082] Fig. 45f is a fragmentary cross sectional illustration of the system of Fig. 45e during the displacement of the adjustable expansion device assembly to radially expand another portion of the tubular liner hanger.

[0083] Fig. 45g is a fragmentary cross sectional illustration of the system of Fig. 45f following the removal of the system from the wellbore.

[0084] Fig. 46a is a fragmentary cross sectional illustration of an exemplary embodiment of a radial expansion system positioned within a cased section of a wellbore.

[0085] Fig. 46b is a fragmentary cross sectional illustration of the system of Fig. 46a following the placement of a plug within the throat passage of the system.

[0086] Fig. 46c is a fragmentary cross sectional illustration of the system of Fig. 46b during the injection of fluidic materials to burst the burst disc of the system.

[0087] Fig. 46d is a fragmentary cross sectional illustration of the system of Fig. 46c during the continued injection of fluidic materials to radially expand and plastically deform at least a portion of the tubular liner hanger.

[0088] Fig. 46e is a fragmentary cross sectional illustration of the system of Fig. 46d during the continued injection of fluidic materials to adjust the size of the adjustable expansion device assembly.

[0089] Fig. 46f is a fragmentary cross sectional illustration of the system of Fig. 46e during the displacement of the adjustable expansion device assembly to radially expand another portion of the tubular liner hanger.

[0090] Fig. 46g is a top view of a portion of an exemplary embodiment of an expansion limiter sleeve prior to the radial expansion and plastic deformation of the expansion limiter sleeve.

[0091] Fig. 46h is a top view of a portion of the expansion limiter sleeve of Fig. 46g after the radial expansion and plastic deformation of the expansion limiter sleeve.

[0092] Fig. 46i is a top view of a portion of an exemplary embodiment of an expansion limiter sleeve prior to the radial expansion and plastic deformation of the expansion limiter sleeve.

[0093] Fig. 46ia is a fragmentary cross sectional view of the expansion limiter sleeve of Fig. 46i.

[0094] Fig. 46j is a top view of a portion of the expansion limiter sleeve of Fig. 46i after the radial expansion and plastic deformation of the expansion limiter sleeve.

[0095]

Detailed Description of the Illustrative Embodiments

[0096] Referring initially to Fig. 1, an exemplary embodiment of an expandable tubular assembly 10 includes a first expandable tubular member 12 coupled to a second expandable tubular member 14. In several exemplary embodiments, the ends of the first and second expandable tubular members, 12 and 14, are coupled using, for example, a conventional mechanical coupling, a welded connection, a brazed connection, a threaded connection, and/or an interference fit connection. In an exemplary embodiment, the first expandable tubular member 12 has a plastic yield point YP_1 , and the second expandable tubular member 14 has a plastic yield point YP_2 . In an exemplary embodiment, the expandable tubular assembly 10 is positioned within a preexisting structure such as, for example, a wellbore 16 that traverses a subterranean formation 18.

[0097] As illustrated in Fig. 2, an expansion device 20 may then be positioned within the second expandable tubular member 14. In several exemplary embodiments, the expansion device 20 may include, for example, one or more of the following conventional expansion devices: a) an expansion cone; b) a rotary expansion device; c) a hydroforming expansion device; d) an impulsive force expansion device; e) any one of the expansion devices commercially available from, or disclosed in any of the published patent applications or issued patents, of Weatherford International, Baker Hughes, Halliburton Energy Services, Shell Oil Co., Schlumberger, and/or Enventure Global Technology L.L.C. In several exemplary embodiments, the expansion device 20 is positioned within the second expandable tubular member 14 before, during, or after the placement of the expandable tubular assembly 10 within the preexisting structure 16.

[0098] As illustrated in Fig. 3, the expansion device 20 may then be operated to radially expand and plastically deform at least a portion of the second expandable tubular member 14 to form a bell-shaped section.

[0099] As illustrated in Fig. 4, the expansion device 20 may then be operated to radially expand and plastically deform the remaining portion of the second expandable tubular member 14 and at least a portion of the first expandable tubular member 12.

[00100] In an exemplary embodiment, at least a portion of at least a portion of at least one of the first and second expandable tubular members, 12 and 14, are radially expanded into intimate contact with the interior surface of the preexisting structure 16.

[00101] In an exemplary embodiment, as illustrated in Fig. 5, the plastic yield point YP_1 is greater than the plastic yield point YP_2 . In this manner, in an exemplary embodiment, the amount of power and/or energy required to radially expand the second expandable tubular

member 14 is less than the amount of power and/or energy required to radially expand the first expandable tubular member 12.

[00102] In an exemplary embodiment, as illustrated in Fig. 6, the first expandable tubular member 12 and/or the second expandable tubular member 14 have a ductility D_{PE} and a yield strength YS_{PE} prior to radial expansion and plastic deformation, and a ductility D_{AE} and a yield strength YS_{AE} after radial expansion and plastic deformation. In an exemplary embodiment, D_{PE} is greater than D_{AE} , and YS_{AE} is greater than YS_{PE} . In this manner, the first expandable tubular member 12 and/or the second expandable tubular member 14 are transformed during the radial expansion and plastic deformation process. Furthermore, in this manner, in an exemplary embodiment, the amount of power and/or energy required to radially expand each unit length of the first and/or second expandable tubular members, 12 and 14, is reduced. Furthermore, because the YS_{AE} is greater than YS_{PE} , the collapse strength of the first expandable tubular member 12 and/or the second expandable tubular member 14 is increased after the radial expansion and plastic deformation process.

[00103] In an exemplary embodiment, as illustrated in Fig. 7, following the completion of the radial expansion and plastic deformation of the expandable tubular assembly 10 described above with reference to Figs. 1-4, at least a portion of the second expandable tubular member 14 has an inside diameter that is greater than at least the inside diameter of the first expandable tubular member 12. In this manner a bell-shaped section is formed using at least a portion of the second expandable tubular member 14. Another expandable tubular assembly 22 that includes a first expandable tubular member 24 and a second expandable tubular member 26 may then be positioned in overlapping relation to the first expandable tubular assembly 10 and radially expanded and plastically deformed using the methods described above with reference to Figs. 1-4. Furthermore, following the completion of the radial expansion and plastic deformation of the expandable tubular assembly 20, in an exemplary embodiment, at least a portion of the second expandable tubular member 26 has an inside diameter that is greater than at least the inside diameter of the first expandable tubular member 24. In this manner a bell-shaped section is formed using at least a portion of the second expandable tubular member 26. Furthermore, in this manner, a mono-diameter tubular assembly is formed that defines an internal passage 28 having a substantially constant cross-sectional area and/or inside diameter.

[00104] Referring to Fig. 8, an exemplary embodiment of an expandable tubular assembly 100 includes a first expandable tubular member 102 coupled to a tubular coupling 104. The tubular coupling 104 is coupled to a tubular coupling 106. The tubular coupling 106 is coupled to a second expandable tubular member 108. In several exemplary embodiments, the tubular couplings, 104 and 106, provide a tubular coupling assembly for coupling the first and second expandable tubular members, 102 and 108, together that may include, for

example, a conventional mechanical coupling, a welded connection, a brazed connection, a threaded connection, and/or an interference fit connection. In an exemplary embodiment, the first and second expandable tubular members 12 have a plastic yield point YP_1 , and the tubular couplings, 104 and 106, have a plastic yield point YP_2 . In an exemplary embodiment, the expandable tubular assembly 100 is positioned within a preexisting structure such as, for example, a wellbore 110 that traverses a subterranean formation 112.

[00105] As illustrated in Fig. 9, an expansion device 114 may then be positioned within the second expandable tubular member 108. In several exemplary embodiments, the expansion device 114 may include, for example, one or more of the following conventional expansion devices: a) an expansion cone; b) a rotary expansion device; c) a hydroforming expansion device; d) an impulsive force expansion device; e) any one of the expansion devices commercially available from, or disclosed in any of the published patent applications or issued patents, of Weatherford International, Baker Hughes, Halliburton Energy Services, Shell Oil Co., Schlumberger, and/or Enventure Global Technology L.L.C. In several exemplary embodiments, the expansion device 114 is positioned within the second expandable tubular member 108 before, during, or after the placement of the expandable tubular assembly 100 within the preexisting structure 110.

[00106] As illustrated in Fig. 10, the expansion device 114 may then be operated to radially expand and plastically deform at least a portion of the second expandable tubular member 108 to form a bell-shaped section.

[00107] As illustrated in Fig. 11, the expansion device 114 may then be operated to radially expand and plastically deform the remaining portion of the second expandable tubular member 108, the tubular couplings, 104 and 106, and at least a portion of the first expandable tubular member 102.

[00108] In an exemplary embodiment, at least a portion of at least a portion of at least one of the first and second expandable tubular members, 102 and 108, are radially expanded into intimate contact with the interior surface of the preexisting structure 110.

[00109] In an exemplary embodiment, as illustrated in Fig. 12, the plastic yield point YP_1 is less than the plastic yield point YP_2 . In this manner, in an exemplary embodiment, the amount of power and/or energy required to radially expand each unit length of the first and second expandable tubular members, 102 and 108, is less than the amount of power and/or energy required to radially expand each unit length of the tubular couplings, 104 and 106.

[00110] In an exemplary embodiment, as illustrated in Fig. 13, the first expandable tubular member 12 and/or the second expandable tubular member 14 have a ductility D_{PE} and a yield strength YS_{PE} prior to radial expansion and plastic deformation, and a ductility D_{AE} and a yield strength YS_{AE} after radial expansion and plastic deformation. In an exemplary embodiment, D_{PE} is greater than D_{AE} , and YS_{AE} is greater than YS_{PE} . In this manner, the first

expandable tubular member 12 and/or the second expandable tubular member 14 are transformed during the radial expansion and plastic deformation process. Furthermore, in this manner, in an exemplary embodiment, the amount of power and/or energy required to radially expand each unit length of the first and/or second expandable tubular members, 12 and 14, is reduced. Furthermore, because the YS_{AE} is greater than YS_{PE} , the collapse strength of the first expandable tubular member 12 and/or the second expandable tubular member 14 is increased after the radial expansion and plastic deformation process.

[00111] Referring to Fig. 14, an exemplary embodiment of an expandable tubular assembly 200 includes a first expandable tubular member 202 coupled to a second expandable tubular member 204 that defines radial openings 204a, 204b, 204c, and 204d. In several exemplary embodiments, the ends of the first and second expandable tubular members, 202 and 204, are coupled using, for example, a conventional mechanical coupling, a welded connection, a brazed connection, a threaded connection, and/or an interference fit connection. In an exemplary embodiment, one or more of the radial openings, 204a, 204b, 204c, and 204d, have circular, oval, square, and/or irregular cross sections and/or include portions that extend to and interrupt either end of the second expandable tubular member 204. In an exemplary embodiment, the expandable tubular assembly 200 is positioned within a preexisting structure such as, for example, a wellbore 206 that traverses a subterranean formation 208.

[00112] As illustrated in Fig. 15, an expansion device 210 may then be positioned within the second expandable tubular member 204. In several exemplary embodiments, the expansion device 210 may include, for example, one or more of the following conventional expansion devices: a) an expansion cone; b) a rotary expansion device; c) a hydroforming expansion device; d) an impulsive force expansion device; d) any one of the expansion devices commercially available from, or disclosed in any of the published patent applications or issued patents, of Weatherford International, Baker Hughes, Halliburton Energy Services, Shell Oil Co., Schlumberger, and/or Enventure Global Technology L.L.C. In several exemplary embodiments, the expansion device 210 is positioned within the second expandable tubular member 204 before, during, or after the placement of the expandable tubular assembly 200 within the preexisting structure 206.

[00113] As illustrated in Fig. 16, the expansion device 210 may then be operated to radially expand and plastically deform at least a portion of the second expandable tubular member 204 to form a bell-shaped section.

[00114] As illustrated in Fig. 16, the expansion device 20 may then be operated to radially expand and plastically deform the remaining portion of the second expandable tubular member 204 and at least a portion of the first expandable tubular member 202.

[00115] In an exemplary embodiment, the anisotropy ratio AR for the first and second

expandable tubular members is defined by the following equation:

$$AR = \ln (WT_f/WT_o)/\ln (D_f/D_o);$$

where AR = anisotropy ratio;

where WT_f = final wall thickness of the expandable tubular member following the radial expansion and plastic deformation of the expandable tubular member;

where WT_i = initial wall thickness of the expandable tubular member prior to the radial expansion and plastic deformation of the expandable tubular member;

where D_f = final inside diameter of the expandable tubular member following the radial expansion and plastic deformation of the expandable tubular member; and

where D_i = initial inside diameter of the expandable tubular member prior to the radial expansion and plastic deformation of the expandable tubular member.

[00116] In an exemplary embodiment, the anisotropy ratio AR for the first and/or second expandable tubular members, 204 and 204, is greater than 1.

[00117] In an exemplary experimental embodiment, the second expandable tubular member 204 had an anisotropy ratio AR greater than 1, and the radial expansion and plastic deformation of the second expandable tubular member did not result in any of the openings, 204a, 204b, 204c, and 204d, splitting or otherwise fracturing the remaining portions of the second expandable tubular member. This was an unexpected result.

[00118] Referring to Fig. 18, in an exemplary embodiment, one or more of the expandable tubular members, 12, 14, 24, 26, 102, 104, 106, 108, 202 and/or 204 are processed using a method 300 in which a tubular member in an initial state is thermo-mechanically processed in step 302. In an exemplary embodiment, the thermo-mechanical processing 302 includes one or more heat treating and/or mechanical forming processes. As a result, of the thermo-mechanical processing 302, the tubular member is transformed to an intermediate state. The tubular member is then further thermo-mechanically processed in step 304. In an exemplary embodiment, the thermo-mechanical processing 304 includes one or more heat treating and/or mechanical forming processes. As a result, of the thermo-mechanical processing 304, the tubular member is transformed to a final state.

[00119] In an exemplary embodiment, as illustrated in Fig. 19, during the operation of the method 300, the tubular member has a ductility D_{PE} and a yield strength YS_{PE} prior to the final thermo-mechanical processing in step 304, and a ductility D_{AE} and a yield strength YS_{AE} after final thermo-mechanical processing. In an exemplary embodiment, D_{PE} is greater than D_{AE} , and YS_{AE} is greater than YS_{PE} . In this manner, the amount of energy and/or power required to transform the tubular member, using mechanical forming processes, during the final thermo-mechanical processing in step 304 is reduced. Furthermore, in this manner, because the YS_{AE} is greater than YS_{PE} , the collapse strength of the tubular member is increased after the final thermo-mechanical processing in step 304.

[00120] In an exemplary embodiment, one or more of the expandable tubular members, 12, 14, 24, 26, 102, 104, 106, 108, 202 and/or 204, have the following characteristics:

Characteristic	Value
Tensile Strength	60 to 120 ksi
Yield Strength	50 to 100 ksi
Y/T Ratio	Maximum of 50/85 %
Elongation During Radial Expansion and Plastic Deformation	Minimum of 35 %
Width Reduction During Radial Expansion and Plastic Deformation	Minimum of 40 %
Wall Thickness Reduction During Radial Expansion and Plastic Deformation	Minimum of 30 %
Anisotropy	Minimum of 1.5
Minimum Absorbed Energy at -4 F (-20 C) in the Longitudinal Direction	80 ft-lb
Minimum Absorbed Energy at -4 F (-20 C) in the Transverse Direction	60 ft-lb
Minimum Absorbed Energy at -4 F (-20 C) Transverse To A Weld Area	60 ft-lb
Flare Expansion Testing	Minimum of 75% Without A Failure
Increase in Yield Strength Due To Radial Expansion and Plastic Deformation	Greater than 5.4 %

[00121] In an exemplary embodiment, one or more of the expandable tubular members, 12, 14, 24, 26, 102, 104, 106, 108, 202 and/or 204, are characterized by an expandability coefficient f:

- i. $f = r \times n$
- ii. where f = expandability coefficient;
 1. r = anisotropy coefficient; and

2. n = strain hardening exponent.

[00122] In an exemplary embodiment, the anisotropy coefficient for one or more of the expandable tubular members, 12, 14, 24, 26, 102, 104, 106, 108, 202 and/or 204 is greater than 1. In an exemplary embodiment, the strain hardening exponent for one or more of the expandable tubular members, 12, 14, 24, 26, 102, 104, 106, 108, 202 and/or 204 is greater than 0.12. In an exemplary embodiment, the expandability coefficient for one or more of the expandable tubular members, 12, 14, 24, 26, 102, 104, 106, 108, 202 and/or 204 is greater than 0.12.

[00123] In an exemplary embodiment, a tubular member having a higher expandability coefficient requires less power and/or energy to radially expand and plastically deform each unit length than a tubular member having a lower expandability coefficient. In an exemplary embodiment, a tubular member having a higher expandability coefficient requires less power and/or energy per unit length to radially expand and plastically deform than a tubular member having a lower expandability coefficient.

[00124] In several exemplary experimental embodiments, one or more of the expandable tubular members, 12, 14, 24, 26, 102, 104, 106, 108, 202 and/or 204, are steel alloys having one of the following compositions:

	Element and Percentage By Weight							
Steel Alloy	C	Mn	P	S	Si	Cu	Ni	Cr
A	0.065	1.44	0.01	0.002	0.24	0.01	0.01	0.02
B	0.18	1.28	0.017	0.004	0.29	0.01	0.01	0.03
C	0.08	0.82	0.006	0.003	0.30	0.16	0.05	0.05
D	0.02	1.31	0.02	0.001	0.45	-	9.1	18.7

[00125] In exemplary experimental embodiment, as illustrated in Fig. 20, a sample of an expandable tubular member composed of Alloy A exhibited a yield point before radial expansion and plastic deformation $Y_{P_{BE}}$, a yield point after radial expansion and plastic deformation of about 16 % $Y_{P_{AE16\%}}$, and a yield point after radial expansion and plastic deformation of about 24 % $Y_{P_{AE24\%}}$. In an exemplary experimental embodiment, $Y_{P_{AE24\%}} > Y_{P_{AE16\%}} > Y_{P_{BE}}$. Furthermore, in an exemplary experimental embodiment, the ductility of the sample of the expandable tubular member composed of Alloy A also exhibited a higher ductility prior to radial expansion and plastic deformation than after radial expansion and plastic deformation. These were unexpected results.

[00126] In an exemplary experimental embodiment, a sample of an expandable tubular member composed of Alloy A exhibited the following tensile characteristics before and after

radial expansion and plastic deformation:

	Yield Point ksi	Yield Ratio	Elongation %	Width Reduction %	Wall Thickness Reduction %	Anisotropy
Before Radial Expansion and Plastic Deformation	46.9	0.69	53	-52	55	0.93
After 16% Radial Expansion	65.9	0.83	17	42	51	0.78
After 24% Radial Expansion	68.5	0.83	5	44	54	0.76
% Increase	40% for 16% radial expansion 46% for 24% radial expansion					

[00127] In exemplary experimental embodiment, as illustrated in Fig. 21, a sample of an expandable tubular member composed of Alloy B exhibited a yield point before radial expansion and plastic deformation $Y_{P_{BE}}$, a yield point after radial expansion and plastic deformation of about 16 % $Y_{P_{AE16\%}}$, and a yield point after radial expansion and plastic deformation of about 24 % $Y_{P_{AE24\%}}$. In an exemplary embodiment, $Y_{P_{AE24\%}} > Y_{P_{AE16\%}} > Y_{P_{BE}}$. Furthermore, in an exemplary experimental embodiment, the ductility of the sample of the expandable tubular member composed of Alloy B also exhibited a higher ductility prior to radial expansion and plastic deformation than after radial expansion and plastic deformation. These were unexpected results.

[00128] In an exemplary experimental embodiment, a sample of an expandable tubular member composed of Alloy B exhibited the following tensile characteristics before and after

radial expansion and plastic deformation:

	Yield Point ksi	Yield Ratio	Elongation %	Width Reduction %	Wall Thickness Reduction %	Anisotropy
Before Radial Expansion and Plastic Deformation	57.8	0.71	44	43	46	0.93
After 16% Radial Expansion	74.4	0.84	16	38	42	0.87
After 24% Radial Expansion	79.8	0.86	20	36	42	0.81
% Increase	28.7% increase for 16% radial expansion 38% increase for 24% radial expansion					

[00129] In an exemplary experimental embodiment, samples of expandable tubulars composed of Alloys A, B, C, and D exhibited the following tensile characteristics prior to radial expansion and plastic deformation:

Steel Alloy	Yield ksi	Yield Ratio	Elongation %	Anisotropy	Absorbed Energy ft-lb	Expandability Coefficient
A	47.6	0.71	44	1.48	145	
B	57.8	0.71	44	1.04	62.2	
C	61.7	0.80	39	1.92	268	

Steel Alloy	Yield ksi	Yield Ratio	Elongation %	Anisotropy	Absorbed Energy ft-lb	Expandability Coefficient
D	48	0.55	56	1.34	-	

[00130] In an exemplary embodiment, one or more of the expandable tubular members, 12, 14, 24, 26, 102, 104, 106, 108, 202 and/or 204 have a strain hardening exponent greater than 0.12, and a yield ratio is less than 0.85.

[00131] In an exemplary embodiment, the carbon equivalent C_e , for tubular members having a carbon content (by weight percentage) less than or equal to 0.12%, is given by the following expression:

$$C_e = C + Mn/6 + (Cr + Mo + V + Ti + Nb)/5 + (Ni + Cu)/15$$

- where C_e = carbon equivalent value;
- a. C = carbon percentage by weight;
 - b. Mn = manganese percentage by weight;
 - c. Cr = chromium percentage by weight;
 - d. Mo = molybdenum percentage by weight;
 - e. V = vanadium percentage by weight;
 - f. Ti = titanium percentage by weight;
 - g. Nb = niobium percentage by weight;
 - h. Ni = nickel percentage by weight; and
 - i. Cu = copper percentage by weight.

[00132] In an exemplary embodiment, the carbon equivalent value C_e , for tubular members having a carbon content less than or equal to 0.12% (by weight), for one or more of the expandable tubular members, 12, 14, 24, 26, 102, 104, 106, 108, 202 and/or 204 is less than 0.21.

[00133] In an exemplary embodiment, the carbon equivalent C_e , for tubular members having more than 0.12% carbon content (by weight), is given by the following expression:

$$C_e = C + Si/30 + (Mn + Cu + Cr)/20 + Ni/60 + Mo/15 + V/10 + 5 * B$$

- where C_e = carbon equivalent value;
- a. C = carbon percentage by weight;
 - b. Si = silicon percentage by weight;
 - c. Mn = manganese percentage by weight;
 - d. Cu = copper percentage by weight;
 - e. Cr = chromium percentage by weight;
 - f. Ni = nickel percentage by weight;

- g. Mo = molybdenum percentage by weight;
- h. V = vanadium percentage by weight; and
- i. B = boron percentage by weight.

[00134] In an exemplary embodiment, the carbon equivalent value C_e , for tubular members having greater than 0.12% carbon content (by weight), for one or more of the expandable tubular members, 12, 14, 24, 26, 102, 104, 106, 108, 202 and/or 204 is less than 0.36.

[00135] In several exemplary embodiments, the first and second tubular members described above with reference to Figs. 1 to 21 are radially expanded and plastically deformed using the expansion device in a conventional manner and/or using one or more of the methods and apparatus disclosed in one or more of the following: The present application is related to the following: (1) U.S. patent application serial no. 09/454,139, attorney docket no. 25791.03.02, filed on 12/3/1999, (2) U.S. patent application serial no. 09/510,913, attorney docket no. 25791.7.02, filed on 2/23/2000, (3) U.S. patent application serial no. 09/502,350, attorney docket no. 25791.8.02, filed on 2/10/2000, (4) U.S. patent application serial no. 09/440,338, attorney docket no. 25791.9.02, filed on 11/15/1999, (5) U.S. patent application serial no. 09/523,460, attorney docket no. 25791.11.02, filed on 3/10/2000, (6) U.S. patent application serial no. 09/512,895, attorney docket no. 25791.12.02, filed on 2/24/2000, (7) U.S. patent application serial no. 09/511,941, attorney docket no. 25791.16.02, filed on 2/24/2000, (8) U.S. patent application serial no. 09/588,946, attorney docket no. 25791.17.02, filed on 6/7/2000, (9) U.S. patent application serial no. 09/559,122, attorney docket no. 25791.23.02, filed on 4/26/2000, (10) PCT patent application serial no. PCT/US00/18635, attorney docket no. 25791.25.02, filed on 7/9/2000, (11) U.S. provisional patent application serial no. 60/162,671, attorney docket no. 25791.27, filed on 11/1/1999, (12) U.S. provisional patent application serial no. 60/154,047, attorney docket no. 25791.29, filed on 9/16/1999, (13) U.S. provisional patent application serial no. 60/159,082, attorney docket no. 25791.34, filed on 10/12/1999, (14) U.S. provisional patent application serial no. 60/159,039, attorney docket no. 25791.36, filed on 10/12/1999, (15) U.S. provisional patent application serial no. 60/159,033, attorney docket no. 25791.37, filed on 10/12/1999, (16) U.S. provisional patent application serial no. 60/212,359, attorney docket no. 25791.38, filed on 6/19/2000, (17) U.S. provisional patent application serial no. 60/165,228, attorney docket no. 25791.39, filed on 11/12/1999, (18) U.S. provisional patent application serial no. 60/221,443, attorney docket no. 25791.45, filed on 7/28/2000, (19) U.S. provisional patent application serial no. 60/221,645, attorney docket no. 25791.46, filed on 7/28/2000, (20) U.S. provisional patent application serial no. 60/233,638, attorney docket no. 25791.47, filed on 9/18/2000, (21) U.S. provisional patent application serial no. 60/237,334, attorney docket no. 25791.48, filed on 10/2/2000, (22) U.S. provisional patent application

serial no. 60/270,007, attorney docket no. 25791.50, filed on 2/20/2001, (23) U.S. provisional patent application serial no. 60/262,434, attorney docket no. 25791.51, filed on 1/17/2001, (24) U.S. provisional patent application serial no. 60/259,486, attorney docket no. 25791.52, filed on 1/3/2001, (25) U.S. provisional patent application serial no. 60/303,740, attorney docket no. 25791.61, filed on 7/6/2001, (26) U.S. provisional patent application serial no. 60/313,453, attorney docket no. 25791.59, filed on 8/20/2001, (27) U.S. provisional patent application serial no. 60/317,985, attorney docket no. 25791.67, filed on 9/6/2001, (28) U.S. provisional patent application serial no. 60/3318,386, attorney docket no. 25791.67.02, filed on 9/10/2001, (29) U.S. utility patent application serial no. 09/969,922, attorney docket no. 25791.69, filed on 10/3/2001, (30) U.S. utility patent application serial no. 10/016,467, attorney docket no. 25791.70, filed on December 10, 2001, (31) U.S. provisional patent application serial no. 60/343,674, attorney docket no. 25791.68, filed on 12/27/2001; and (32) U.S. provisional patent application serial no. 60/346,309, attorney docket no. 25791.92, filed on 01/07/02, the disclosures of which are incorporated herein by reference.

[00136] Referring to Fig. 35a an exemplary embodiment of an expandable tubular member 3500 includes a first tubular region 3502 and a second tubular portion 3504. In an exemplary embodiment, the material properties of the first and second tubular regions, 3502 and 3504, are different. In an exemplary embodiment, the yield points of the first and second tubular regions, 3502 and 3504, are different. In an exemplary embodiment, the yield point of the first tubular region 3502 is less than the yield point of the second tubular region 3504. In several exemplary embodiments, one or more of the expandable tubular members, 12, 14, 24, 26, 102, 104, 106, 108, 202 and/or 204 incorporate the tubular member 3500.

[00137] Referring to Fig. 35b, in an exemplary embodiment, the yield point within the first and second tubular regions, 3502a and 3502b, of the expandable tubular member 3502 vary as a function of the radial position within the expandable tubular member. In an exemplary embodiment, the yield point increases as a function of the radial position within the expandable tubular member 3502. In an exemplary embodiment, the relationship between the yield point and the radial position within the expandable tubular member 3502 is a linear relationship. In an exemplary embodiment, the relationship between the yield point and the radial position within the expandable tubular member 3502 is a non-linear relationship. In an exemplary embodiment, the yield point increases at different rates within the first and second tubular regions, 3502a and 3502b, as a function of the radial position within the expandable tubular member 3502. In an exemplary embodiment, the functional relationship, and value, of the yield points within the first and second tubular regions, 3502a and 3502b, of the expandable tubular member 3502 are modified by the radial expansion and plastic deformation of the expandable tubular member.

[00138] In several exemplary embodiments, one or more of the expandable tubular members, 12, 14, 24, 26, 102, 104, 106, 108, 202, 204 and/or 3502, prior to a radial expansion and plastic deformation, include a microstructure that is a combination of a hard phase, such as martensite, a soft phase, such as ferrite, and a transitionary phase, such as retained austenite. In this manner, the hard phase provides high strength, the soft phase provides ductility, and the transitionary phase transitions to a hard phase, such as martensite, during a radial expansion and plastic deformation. Furthermore, in this manner, the yield point of the tubular member increases as a result of the radial expansion and plastic deformation. Further, in this manner, the tubular member is ductile, prior to the radial expansion and plastic deformation, thereby facilitating the radial expansion and plastic deformation. In an exemplary embodiment, the composition of a dual-phase expandable tubular member includes (weight percentages): about 0.1% C, 1.2% Mn, and 0.3% Si.

[00139] In an exemplary experimental embodiment, as illustrated in Figs. 36a-36c, one or more of the expandable tubular members, 12, 14, 24, 26, 102, 104, 106, 108, 202, 204 and/or 3502 are processed in accordance with a method 3600, in which, in step 3602, an expandable tubular member 3602a is provided that is a steel alloy having following material composition (by weight percentage): 0.065% C, 1.44% Mn, 0.01% P, 0.002% S, 0.24% Si, 0.01% Cu, 0.01% Ni, 0.02% Cr, 0.05% V, 0.01% Mo, 0.01% Nb, and 0.01% Ti. In an exemplary experimental embodiment, the expandable tubular member 3602a provided in step 3602 has a yield strength of 45 ksi, and a tensile strength of 69 ksi.

[00140] In an exemplary experimental embodiment, as illustrated in Fig. 36b, in step 3602, the expandable tubular member 3602a includes a microstructure that includes martensite, pearlite, and V, Ni, and/or Ti carbides.

[00141] In an exemplary embodiment, the expandable tubular member 3602a is then heated at a temperature of 790 °C for about 10 minutes in step 3604.

[00142] In an exemplary embodiment, the expandable tubular member 3602a is then quenched in water in step 3606.

[00143] In an exemplary experimental embodiment, as illustrated in Fig. 36c, following the completion of step 3606, the expandable tubular member 3602a includes a microstructure that includes new ferrite, grain pearlite, martensite, and ferrite. In an exemplary experimental embodiment, following the completion of step 3606, the expandable tubular member 3602a has a yield strength of 67 ksi, and a tensile strength of 95 ksi.

[00144] In an exemplary embodiment, the expandable tubular member 3602a is then radially expanded and plastically deformed using one or more of the methods and apparatus described above. In an exemplary embodiment, following the radial expansion and plastic deformation of the expandable tubular member 3602a, the yield strength of the expandable tubular member is about 95 ksi.

[00145] In an exemplary experimental embodiment, as illustrated in Figs. 37a-37c, one or more of the expandable tubular members, 12, 14, 24, 26, 102, 104, 106, 108, 202, 204 and/or 3502 are processed in accordance with a method 3700, in which, in step 3702, an expandable tubular member 3702a is provided that is a steel alloy having following material composition (by weight percentage): 0.18% C, 1.28% Mn, 0.017% P, 0.004% S, 0.29% Si, 0.01% Cu, 0.01% Ni, 0.03% Cr, 0.04% V, 0.01%Mo, 0.03% Nb, and 0.01% Ti. In an exemplary experimental embodiment, the expandable tubular member 3702a provided in step 3702 has a yield strength of 60 ksi, and a tensile strength of 80 ksi.

[00146] In an exemplary experimental embodiment, as illustrated in Fig. 37b, in step 3702, the expandable tubular member 3702a includes a microstructure that includes pearlite and pearlite striation.

[00147] In an exemplary embodiment, the expandable tubular member 3702a is then heated at a temperature of 790 °C for about 10 minutes in step 3704.

[00148] In an exemplary embodiment, the expandable tubular member 3702a is then quenched in water in step 3706.

[00149] In an exemplary experimental embodiment, as illustrated in Fig. 37c, following the completion of step 3706, the expandable tubular member 3702a includes a microstructure that includes ferrite, martensite, and bainite. In an exemplary experimental embodiment, following the completion of step 3706, the expandable tubular member 3702a has a yield strength of 82 ksi, and a tensile strength of 130 ksi.

[00150] In an exemplary embodiment, the expandable tubular member 3702a is then radially expanded and plastically deformed using one or more of the methods and apparatus described above. In an exemplary embodiment, following the radial expansion and plastic deformation of the expandable tubular member 3702a, the yield strength of the expandable tubular member is about 130 ksi.

[00151] In an exemplary experimental embodiment, as illustrated in Figs. 38a-38c, one or more of the expandable tubular members, 12, 14, 24, 26, 102, 104, 106, 108, 202, 204 and/or 3502 are processed in accordance with a method 3800, in which, in step 3802, an expandable tubular member 3802a is provided that is a steel alloy having following material composition (by weight percentage): 0.08% C, 0.82% Mn, 0.006% P, 0.003% S, 0.30% Si, 0.06% Cu, 0.05% Ni, 0.05% Cr, 0.03% V, 0.03%Mo, 0.01% Nb, and 0.01% Ti. In an exemplary experimental embodiment, the expandable tubular member 3802a provided in step 3802 has a yield strength of 56 ksi, and a tensile strength of 75 ksi.

[00152] In an exemplary experimental embodiment, as illustrated in Fig. 38b, in step 3802, the expandable tubular member 3802a includes a microstructure that includes grain pearlite, widmanstatten martensite and carbides of V, Ni, and/or Ti.

[00153] In an exemplary embodiment, the expandable tubular member 3802a is then heated at a temperature of 790 °C for about 10 minutes in step 3804.

[00154] In an exemplary embodiment, the expandable tubular member 3802a is then quenched in water in step 3806.

[00155] In an exemplary experimental embodiment, as illustrated in Fig. 38c, following the completion of step 3806, the expandable tubular member 3802a includes a microstructure that includes bainite, pearlite, and new ferrite. In an exemplary experimental embodiment, following the completion of step 3806, the expandable tubular member 3802a has a yield strength of 60 ksi, and a tensile strength of 97 ksi.

[00156] In an exemplary embodiment, the expandable tubular member 3802a is then radially expanded and plastically deformed using one or more of the methods and apparatus described above. In an exemplary embodiment, following the radial expansion and plastic deformation of the expandable tubular member 3802a, the yield strength of the expandable tubular member is about 97 ksi.

[00157] In several exemplary embodiments, the teachings of the present disclosure are combined with one or more of the teachings disclosed in FR 2 841 626, filed on 6/28/2002, and published on 1/2/2004, the disclosure of which is incorporated herein by reference.

[00158] Referring to Figs. 39a-39f, an exemplary embodiment of an expansion system 3900 includes an adjustable expansion device 3902 and a hydroforming expansion device 3904 that are both coupled to a support member 3906.

[00159] In several exemplary embodiments, the adjustable expansion device 3902 includes one or more elements of conventional adjustable expansion devices and/or one or more elements of the adjustable expansion devices disclosed in one or more of the related applications referenced above and/or one or more elements of the conventional commercially available adjustable expansion devices available from Baker Hughes, Weatherford International, Schlumberger, and/or Enventure Global Technology L.L.C. In several exemplary embodiments, the hydroforming expansion device 3904 includes one or more elements of conventional hydroforming expansion devices and/or one or more elements of the hydroforming expansion devices disclosed in one or more of the related applications referenced above and/or one or more elements of the conventional commercially available hydroforming devices available from Baker Hughes, Weatherford International, Schlumberger, and/or Enventure Global Technology L.L.C. and/or one or more elements of the hydroforming expansion devices disclosed in U.S. Patent No. 5,901,594, the disclosure of which is incorporated herein by reference. In several exemplary embodiments, the adjustable expansion device 3902 and the hydroforming expansion device 3904 may be combined in a single device and/or include one or more elements of each other.

[00160] In an exemplary embodiment, during the operation of the expansion system 3900, as illustrated in Figs. 39a and 39b, the expansion system is positioned within an expandable tubular assembly that includes first and second tubular members, 3908 and 3910, that are coupled end to end and positioned and supported within a preexisting structure such as, for example, a wellbore 3912 that traverses a subterranean formation 3914. In several exemplary embodiments, the first and second tubular members, 3908 and 3910, include one or more of the characteristics of the expandable tubular members described in the present application.

[00161] In an exemplary embodiment, as illustrated in Fig. 39c, the hydroforming expansion device 3904 may then be operated to radially expand and plastically deform a portion of the second tubular member 3910.

[00162] In an exemplary embodiment, as illustrated in Fig. 39d, the hydroforming expansion device 3904 may then be disengaged from the second tubular member 3910.

[00163] In an exemplary embodiment, as illustrated in Fig. 39e, the adjustable expansion device 3902 may then be positioned within the radially expanded portion of the second tubular member 3910 and the size the adjustable expansion device increased.

[00164] In an exemplary embodiment, as illustrated in Fig. 39f, the adjustable expansion device 3902 may then be operated to radially expand and plastically deform one or more portions of the first and second tubular members, 3908 and 3910.

[00165] Referring to Figs. 40a-40g, an exemplary embodiment of an expansion system 4000 includes a hydroforming expansion device 4002 that is coupled to a support member 4004.

[00166] In several exemplary embodiments, the hydroforming expansion device 4002 includes one or more elements of conventional hydroforming expansion devices and/or one or more elements of the hydroforming expansion devices disclosed in one or more of the related applications referenced above and/or one or more elements of the conventional commercially available hydroforming devices available from Baker Hughes, Weatherford International, Schlumberger, and/or Enventure Global Technology L.L.C. and/or one or more elements of the hydroforming expansion devices disclosed in U.S. Patent No. 5,901,594, the disclosure of which is incorporated herein by reference.

[00167] In an exemplary embodiment, during the operation of the expansion system 4000, as illustrated in Figs. 40a and 40b, the expansion system is positioned within an expandable tubular assembly that includes first and second tubular members, 4006 and 4008, that are coupled end to end and positioned and supported within a preexisting structure such as, for example, a wellbore 4010 that traverses a subterranean formation 4012. In several exemplary embodiments, the first and second tubular members, 4004 and

4006, include one or more of the characteristics of the expandable tubular members described in the present application.

[00168] In an exemplary embodiment, as illustrated in Figs. 40c to 40f, the hydroforming expansion device 4002 may then be repeatedly operated to radially expand and plastically deform one or more portions of the first and second tubular members, 4008 and 4010.

[00169] Referring to Figs. 41a-41h, an exemplary embodiment of an expansion system 4100 includes an adjustable expansion device 4102 and a hydroforming expansion device 4104 that are both coupled to a tubular support member 4106.

[00170] In several exemplary embodiments, the adjustable expansion device 4102 includes one or more elements of conventional adjustable expansion devices and/or one or more elements of the adjustable expansion devices disclosed in one or more of the related applications referenced above and/or one or more elements of the conventional commercially available adjustable expansion devices available from Baker Hughes, Weatherford International, Schlumberger, and/or Enventure Global Technology L.L.C. In several exemplary embodiments, the hydroforming expansion device 4104 includes one or more elements of conventional hydroforming expansion devices and/or one or more elements of the hydroforming expansion devices disclosed in one or more of the related applications referenced above and/or one or more elements of the conventional commercially available hydroforming devices available from Baker Hughes, Weatherford International, Schlumberger, and/or Enventure Global Technology L.L.C. and/or one or more elements of the hydroforming expansion devices disclosed in U.S. Patent No. 5,901,594, the disclosure of which is incorporated herein by reference. In several exemplary embodiments, the adjustable expansion device 4102 and the hydroforming expansion device 4104 may be combined in a single device and/or include one or more elements of each other.

[00171] In an exemplary embodiment, during the operation of the expansion system 4100, as illustrated in Figs. 41a and 41b, the expansion system is positioned within an expandable tubular assembly that includes first and second tubular members, 4108 and 4110, that are coupled end to end and positioned and supported within a preexisting structure such as, for example, a wellbore 4112 that traverses a subterranean formation 4114. In an exemplary embodiment, a shoe 4116 having a valveable passage 4118 is coupled to the lower portion of the second tubular member 4110. In several exemplary embodiments, the first and second tubular members, 4108 and 4110, include one or more of the characteristics of the expandable tubular members described in the present application.

[00172] In an exemplary embodiment, as illustrated in Fig. 41c, the hydroforming expansion device 4104 may then be operated to radially expand and plastically deform a portion of the second tubular member 4110.

[00173] In an exemplary embodiment, as illustrated in Fig. 41d, the hydroforming expansion device 4104 may then be disengaged from the second tubular member 4110.

[00174] In an exemplary embodiment, as illustrated in Figs. 41e and 41f, the adjustable expansion device 4102 may then be positioned within the radially expanded portion of the second tubular member 4110 and the size the adjustable expansion device increased. The valveable passage 4118 of the shoe 4116 may then be closed, for example, by placing a ball 4120 within the passage in a conventional manner.

[00175] In an exemplary embodiment, as illustrated in Fig. 41g, the adjustable expansion device 4102 may then be operated to radially expand and plastically deform one or more portions of the first and second tubular members, 4108 and 4110, above the shoe 4116.

[00176] In an exemplary embodiment, as illustrated in Fig. 41h, the expansion system 4100 may then be removed from the tubular assembly and the lower, radially unexpanded, portion of the second tubular member 4110 and the shoe 4116 may be machined away.

[00177] Referring to Figs. 42a-42e, an exemplary embodiment of an expansion system 4200 includes a hydroforming expansion device 4202 that is coupled to a tubular support member 4204. An expandable tubular member 4206 is coupled to and supported by the hydroforming expansion device 4202.

[00178] In several exemplary embodiments, the hydroforming expansion device 4202 includes one or more elements of conventional hydroforming expansion devices and/or one or more elements of the hydroforming expansion devices disclosed in one or more of the related applications referenced above and/or one or more elements of the conventional commercially available hydroforming devices available from Baker Hughes, Weatherford International, Schlumberger, and/or Enventure Global Technology L.L.C. and/or one or more elements of the hydroforming expansion devices disclosed in U.S. Patent No. 5,901,594, the disclosure of which is incorporated herein by reference.

[00179] In several exemplary embodiments, the expandable tubular member 4206 includes one or more of the characteristics of the expandable tubular members described in the present application.

[00180] In an exemplary embodiment, during the operation of the expansion system 4200, as illustrated in Figs. 42a and 42b, the expansion system is positioned within an expandable tubular assembly that includes first and second tubular members, 4208 and 4210, that are coupled end to end and positioned and supported within a preexisting structure such as, for example, a wellbore 4212 that traverses a subterranean formation 4214. In an exemplary embodiment, the second tubular member 4210 includes one or more radial passages 4212. In an exemplary embodiment, the expandable tubular member 4206

is positioned in opposing relation to the radial passages 4212 of the second tubular member 4210.

[00181] In an exemplary embodiment, as illustrated in Fig. 42c, the hydroforming expansion device 4202 may then be operated to radially expand and plastically deform the expandable tubular member 4206 into contact with the interior surface of the second tubular member 4210 thereby covering and sealing off the radial passages 4212 of the second tubular member.

[00182] In an exemplary embodiment, as illustrated in Fig. 42d, the hydroforming expansion device 4202 may then be disengaged from the expandable tubular member 4206.

[00183] In an exemplary embodiment, as illustrated in Figs. 42e, the expansion system 4200 may then be removed from the wellbore 4212.

[00184] Referring to Fig. 43, an exemplary embodiment of a hydroforming expansion system 4300 includes an expansion element 4302 that is provided substantially as disclosed in U.S. Patent No. 5,901,594, the disclosure of which is incorporated herein by reference.

[00185] A flow line 4304 is coupled to the inlet of the expansion element 4302 and the outlet of conventional 2-way/2-position flow control valve 4306. A flow line 4308 is coupled to an inlet of the flow control valve 4306 and an outlet of a conventional accumulator 4310, and a flow line 4312 is coupled to another inlet of the flow control valve and a fluid reservoir 4314.

[00186] A flow line 4316 is coupled to the flow line 4308 and an the inlet of a conventional pressure relief valve 4318, and a flow line 4320 is coupled to the outlet of the pressure relief valve and the fluid reservoir 4314. A flow line 4322 is coupled to the inlet of the accumulator 4310 and the outlet of a conventional check valve 4324.

[00187] A flow line 4326 is coupled to the inlet of the check valve 4324 and the outlet of a conventional pump 4328. A flow line 4330 is coupled to the flow line 4326 and the inlet of a conventional pressure relief valve 4332.

[00188] A flow line 4334 is coupled to the outlet of the pressure relief valve 4332 and the fluid reservoir 4314, and a flow line 4336 is coupled to the inlet of the pump 4328 and the fluid reservoir.

[00189] A controller 4338 is operably coupled to the flow control valve 4306 and the pump 4328 for controlling the operation of the flow control valve and the pump. In an exemplary embodiment, the controller 4338 is a programmable general purpose controller. Conventional pressure sensors, 4340, 4342 and 4344, are operably coupled to the expansion element 4302, the accumulator 4310, and the flow line 4326, respectively, and the controller 4338. A conventional user interface 4346 is operably coupled to the controller 4338.

[00190] During operation of the hydroforming expansion system 4300, as illustrated in Figs. 44a-44b, the system implements a method of operation 4400 in which, in step 4402, the user may select expansion of an expandable tubular member. If the user selects expansion in step 4402, then the controller 4338 determines if the operating pressure of the accumulator 4310, as sensed by the pressure sensor 4342, is greater than or equal to a predetermined value in step 4404.

[00191] If the operating pressure of the accumulator 4310, as sensed by the pressure sensor 4342, is not greater than or equal to the predetermined value in step 4404, then the controller 4338 operates the pump 4328 to increase the operating pressure of the accumulator in step 4406. The controller 4338 then determines if the operating pressure of the accumulator 4310, as sensed by the pressure sensor 4342, is greater than or equal to a predetermined value in step 4408. If the operating pressure of the accumulator 4310, as sensed by the pressure sensor 4342, in step 4408, is not greater than or equal to the predetermined value, then the controller 4338 continues to operate the pump 4328 to increase the operating pressure of the accumulator in step 4406.

[00192] If the operating pressure of the accumulator 4310, as sensed by the pressure sensor 4342, in steps 4404 or 4408, is greater than or equal to the predetermined value, then the controller 4338 operates the flow control valve 4306 to pressurize the expansion element 4302 in step 4410 by positioning the flow control valve to couple the flow lines 4304 and 4308 to one another. If the expansion operation has been completed in step 4412, then the controller 4338 operates the flow control valve 4306 to de-pressurize the expansion element 4302 in step 4414 by positioning the flow control valve to couple the flow lines 4304 and 4312 to one another.

[00193] In several exemplary embodiments, one or more of the hydroforming expansion devices 4002, 4104, and 4202, incorporate one or more elements of the hydroforming expansion system 4300 and/or the operational steps of the method 4400.

[00194] Referring to Fig. 45a, an exemplary embodiment of a liner hanger system 4500 includes a tubular support member 4502 that defines a passage 4502a and includes an externally threaded connection 4502b at an end. An internally threaded connection 4504a of an end of an outer tubular mandrel 4504 that defines a passage 4504b, and includes an external flange 4504c, an internal annular recess 4504d, an external annular recess 4504e, an external annular recess 4504f, an external flange 4504g, an external annular recess 4504h, an internal flange 4504i, an external flange 4504j, and a plurality of circumferentially spaced apart longitudinally aligned teeth 4504k at another end, is coupled to and receives the externally threaded connection 4502b of the end of the tubular support member 4502.

[00195] An end of a tubular liner hanger 4506 that abuts and mates with an end face of the external flange 4504c of the outer tubular mandrel 4504 receives and mates with the outer tubular mandrel, and includes internal teeth 4506a, a plurality of circumferentially spaced apart longitudinally aligned internal teeth 4506b, an internal flange 4506c, and an external threaded connection 4506d at another end. In an exemplary embodiment, at least a portion of the tubular liner hanger 4506 includes one or more of the characteristics of the expandable tubular members described in the present application.

[00196] An internal threaded connection 4508a of an end of a tubular liner 4508 receives and is coupled to the external threaded connection 4506d of the tubular liner hanger 4506. Spaced apart elastomeric sealing elements, 4510, 4512, and 4514, are coupled to the exterior surface of the end of the tubular liner hanger 4506

[00197] An external flange 4516a of an end of an inner tubular mandrel 4516 that defines a longitudinal passage 4516b having a throat 4516ba and a radial passage 4516c and includes a sealing member 4516d mounted upon the external flange for sealingly engaging the inner annular recess 4504d of the outer tubular mandrel 4504, an external flange 4516e at another end that includes a plurality of circumferentially spaced apart teeth 4516f that mate with and engage the teeth, 4504k and 4506b, of the outer tubular mandrel 4504 and the tubular liner hanger 4506, respectively, for transmitting torsional loads therebetween, and another end that is received within and mates with the internal flange 4506c of the tubular liner hanger 4506 mates with and is received within the inner annular recess 4504d of the outer tubular mandrel 4504. A conventional rupture disc 4518 is received within and coupled to the radial passage 4516c of the inner tubular mandrel 4516.

[0001] A conventional packer cup 4520 is mounted within and coupled to the external annular recess 4504e of the outer tubular mandrel 4504 for sealingly engaging the interior surface of the tubular liner hanger 4506. A locking assembly 4522 is mounted upon and coupled to the outer tubular mandrel 4504 proximate the external flange 4504g in opposing relation to the internal teeth 4506a of the tubular liner hanger 4506 for controllably engaging and locking the position of the tubular liner hanger relative to the outer tubular mandrel 4504. In several exemplary embodiments, the locking assembly 4522 may be a conventional locking device for locking the position of a tubular member relative to another member. In several alternative embodiments, the locking assembly 4522 may include one or more elements of the locking assemblies disclosed in one or more of the following: (1) PCT patent application serial number PCT/US02/36157, attorney docket number 25791.87.02, filed on 11/12/2002, (2) PCT patent application serial number PCT/US02/36267, attorney docket number 25791.88.02, filed on 11/12/2002, (3) PCT patent application serial number PCT/US03/04837, attorney docket number 25791.95.02, filed on 2/29/2003, (4) PCT patent application serial number PCT/US03/29859, attorney docket no. 25791.102.02, filed on

9/22/2003, (5) PCT patent application serial number PCT/US03/14153, attorney docket number 25791.104.02, filed on 11/13/2003, (6) PCT patent application serial number PCT/US03/18530, attorney docket number 25791.108.02, filed on 6/11/2003, (7) PCT patent application serial number PCT/US03/29858, attorney docket number 25791.112.02, (8) PCT patent application serial number PCT/US03/29460, attorney docket number 25791.114.02, filed on 9/23/2003, filed on 9/22/2003, (9) PCT patent application serial number PCT/US04/07711, attorney docket number 25791.253.02, filed on 3/11/2004, (10) PCT patent application serial number PCT/US2004/009434, attorney docket number 25791.260.02, filed on 3/26/2004, (11) PCT patent application serial number PCT/US2004/010317, attorney docket number 25791.270.02, filed on 4/2/2004, (12) PCT patent application serial number PCT/US2004/010712, attorney docket number 25791.272.02, filed on 4/7/2004, (13) PCT patent application serial number PCT/US2004/010762, attorney docket number 25791.273.02, filed on 4/6/2004, and/or (14) PCT patent application serial number PCT/US2004/011973, attorney docket number 25791.277.02, filed on April 15, 2004, the disclosures of which are incorporated herein by reference.

[0002] An adjustable expansion device assembly 4524 is mounted upon and coupled to the outer tubular mandrel 4504 between the locking assembly 4522 and the external flange 4504j for controllably radially expanding and plastically deforming the tubular liner hanger 4506. In several exemplary embodiments, the adjustable expansion device assembly 4524 may be a conventional adjustable expansion device assembly for radially expanding and plastically deforming tubular members that may include one or more elements of conventional adjustable expansion cones, mandrels, rotary expansion devices, hydroforming expansion devices and/or one or more elements of the one or more of the commercially available adjustable expansion devices of Enventure Global Technology LLC, Baker Hughes, Weatherford International, and/or Schlumberger and/or one or more elements of the adjustable expansion devices disclosed in one or more of the published patent applications and/or issued patents of Enventure Global Technology LLC, Baker Hughes, Weatherford International, Shell Oil Co. and/or Schlumberger. In several alternative embodiments, the adjustable expansion device assembly 4524 may include one or more elements of the adjustable expansion device assemblies disclosed in one or more of the following: (1) PCT patent application serial number PCT/US02/36157, attorney docket number 25791.87.02, filed on 11/12/2002, (2) PCT patent application serial number PCT/US02/36267, attorney docket number 25791.88.02, filed on 11/12/2002, (3) PCT patent application serial number PCT/US03/04837, attorney docket number 25791.95.02, filed on 2/29/2003, (4) PCT patent application serial number PCT/US03/29859, attorney docket no. 25791.102.02, filed on 9/22/2003, (5) PCT patent application serial number

PCT/US03/14153, attorney docket number 25791.104.02, filed on 11/13/2003, (6) PCT patent application serial number PCT/US03/18530, attorney docket number 25791.108.02, filed on 6/11/2003, (7) PCT patent application serial number PCT/US03/29858, attorney docket number 25791.112.02, (8) PCT patent application serial number PCT/US03/29460, attorney docket number 25791.114.02, filed on 9/23/2003, filed on 9/22/2003, (9) PCT patent application serial number PCT/US04/07711, attorney docket number 25791.253.02, filed on 3/11/2004, (10) PCT patent application serial number PCT/US2004/009434, attorney docket number 25791.260.02, filed on 3/26/2004, (11) PCT patent application serial number PCT/US2004/010317, attorney docket number 25791.270.02, filed on 4/2/2004, (12) PCT patent application serial number PCT/US2004/010712, attorney docket number 25791.272.02, filed on 4/7/2004, (13) PCT patent application serial number PCT/US2004/010762, attorney docket number 25791.273.02, filed on 4/6/2004, and/or (14) PCT patent application serial number PCT/US2004/011973, attorney docket number 25791.277.02, filed on April 15, 2004, the disclosures of which are incorporated herein by reference.

[00198] A conventional SSR plug set 4526 is mounted within and coupled to the internal flange 4506c of the tubular liner hanger 4506.

[00199] In an exemplary embodiment, during operation of the system 4500, as illustrated in Fig. 45a, the system is positioned within a wellbore 4528 that traverses a subterranean formation 4530 and includes a preexisting wellbore casing 4532 coupled to and positioned within the wellbore. In an exemplary embodiment, the system 4500 is positioned such that the tubular liner hanger 4506 overlaps with the casing 4532.

[00200] Referring to Fig. 45b, in an exemplary embodiment, a ball 4534 is then positioned in the throat passage 4516ba by injecting fluidic materials 4536 into the system 4500 through the passages 4502a, 4504b, and 4516b, of the tubular support member 4502, outer tubular mandrel 4504, and inner tubular mandrel 4516, respectively.

[00201] Referring to Fig. 45c, in an exemplary embodiment, the continued injection of the fluidic materials 4536 into the system 4500, following the placement of the ball 4534 in the throat passage 4516ba, pressurizes the passage 4516b of the inner tubular mandrel 4516 such that the rupture disc 4518 is ruptured thereby permitting the fluidic materials to pass through the radial passage 4516c of the inner tubular mandrel. As a result, the interior of the tubular liner hanger 4506 is pressurized.

[00202] Referring to Fig. 45d, in an exemplary embodiment, the continued injection of the fluidic materials 4536 into the interior of the tubular liner hanger 4506 radially expands and plastically deforms at least a portion of the tubular liner hanger. In an exemplary embodiment, the continued injection of the fluidic materials 4536 into the interior of the tubular liner hanger 4506 radially expands and plastically deforms a portion of the tubular

liner hanger positioned in opposition to the adjustable expansion device assembly 4524. In an exemplary embodiment, the continued injection of the fluidic materials 4536 into the interior of the tubular liner hanger 4506 radially expands and plastically deforms a portion of the tubular liner hanger positioned in opposition to the adjustable expansion device assembly 4524 into engagement with the wellbore casing 4532.

[00203] Referring to Fig. 45e, in an exemplary embodiment, the size of the adjustable expansion device assembly 4524 is then increased within the radially expanded portion of the tubular liner hanger 4506, and the locking assembly 4522 is operated to unlock the tubular liner hanger from engagement with the locking assembly. In an exemplary embodiment, the locking assembly 4522 and the adjustable expansion device assembly 4524 are operated using the operating pressure provided by the continued injection of the fluidic materials 4536 into the system 4500. In an exemplary embodiment, the adjustment of the adjustable expansion device assembly 4524 to a larger size radially expands and plastically deforms at least a portion of the tubular liner hanger 4506.

[00204] Referring to Fig. 45f, in an exemplary embodiment, the adjustable expansion device assembly 4524 is displaced in a longitudinal direction relative to the tubular liner hanger 4506 thereby radially expanding and plastically deforming the tubular liner hanger. In an exemplary embodiment, the tubular liner hanger 4506 is radially expanded and plastically deformed into engagement with the casing 4532. In an exemplary embodiment, the adjustable expansion device assembly 4524 is displaced in a longitudinal direction relative to the tubular liner hanger 4506 due to the operating pressure within the tubular liner hanger generated by the continued injection of the fluidic materials 4536. In an exemplary embodiment, the adjustable expansion device assembly 4524 is displaced in a longitudinal direction relative to the tubular liner hanger 4506 due to the operating pressure within the tubular liner hanger below the packer cup 4520 generated by the continued injection of the fluidic materials 4536. In this manner, the adjustable expansion device assembly 4524 is pulled through the tubular liner hanger 4506 by the operation of the packer cup 4520. In an exemplary embodiment, the adjustable expansion device assembly 4524 is displaced in a longitudinal direction relative to the tubular liner hanger 4506 thereby radially expanding and plastically deforming the tubular liner hanger until the internal flange 4504i of the outer tubular mandrel 4504 engages the external flange 4516a of the end of the inner tubular mandrel 4516.

[00205] Referring to Fig. 45g, in an exemplary embodiment, the 4504, due to the engagement of the internal flange 4504i of the outer tubular mandrel 4504 with the external flange 4516a of the end of the inner tubular mandrel 4516, the inner tubular mandrel and the SSR plug set 4526 may be removed from the wellbore 4528. As a result, the tubular liner

4508 is suspended within the wellbore 4528 by virtue of the engagement of the tubular liner hanger 4506 with the wellbore casing 4532.

[00206] In several alternative embodiments, during the operation of the system 4500, a hardenable fluidic sealing material such as, for example, cement, may be injected through the system 4500 before, during or after the radial expansion of the liner hanger 4506 in order to form an annular barrier between the wellbore 4528 and the tubular liner 4508.

[00207] In several alternative embodiments, during the operation of the system 4500, the size of the adjustable expansion device 4524 is increased prior to, during, or after the hydroforming expansion of the tubular liner hanger 4506 caused by the injection of the fluidic materials 4536 into the interior of the tubular liner hanger.

[00208] In several alternative embodiments, at least a portion of the tubular liner hanger 4506 includes a plurality of nested expandable tubular members bonded together by, for example, amorphous bonding.

[00209] In several alternative embodiments, at least a portion of the tubular liner hanger 4506 is fabricated for materials particularly suited for subsequent drilling out operations such as, for example, aluminum and/or copper based materials and alloys.

[00210] In several alternative embodiments, during the operation of the system 4500, the portion of the tubular liner hanger 4506 positioned below the adjustable expansion device 4524 is radially expanded and plastically deformed by displacing the adjustable expansion device downwardly.

[00211] In several alternative embodiments, at least a portion of the tubular liner hanger 4506 is fabricated for materials particularly suited for subsequent drilling out operations such as, for example, aluminum and/or copper based materials and alloys. In several alternative embodiments, during the operation of the system 4500, the portion of the tubular liner hanger 4506 fabricated for materials particularly suited for subsequent drilling out operations is not hydroformed by the injection of the fluidic materials 4536.

[00212] In several alternative embodiments, during the operation of the system 4500, at least a portion of the tubular liner hanger 4506 is hydroformed by the injection of the fluidic materials 4536, the remaining portion of the tubular liner hanger above the initial position of the adjustable expansion device 4524 is then radially expanded and plastically deformed by displacing the adjustable expansion device upwardly, and the portion of the tubular liner hanger below the initial position of the adjustable expansion device is radially expanded by then displacing the adjustable expansion device downwardly.

[00213] In several alternative embodiments, during the operation of the system 4500, the portion of the tubular liner hanger 4506 that is radially expanded and plastically deformed is radially expanded and plastically deformed solely by hydroforming caused by the injection of the fluidic materials 4536.

[00214] In several alternative embodiments, during the operation of the system 4500, the portion of the tubular liner hanger 4506 that is radially expanded and plastically deformed is radially expanded and plastically deformed solely by the adjustment of the adjustable expansion device 4524 to an increased size and the subsequent displacement of the adjustable expansion device relative to the tubular liner hanger.

[00215] Referring to Fig. 46a, an exemplary embodiment of a system 4600 for radially expanding a tubular member includes a tubular support member 4602 that defines a passage 4602a. An end of a conventional tubular safety sub 4604 that defines a passage 4604a is coupled to an end of the tubular support member 4602, and another end of the safety sub 4604 is coupled to an end of a tubular casing lock assembly 4606 that defines a passage 4606a.

[00216] In several exemplary embodiments, the lock assembly 4606 may be a conventional locking device for locking the position of a tubular member relative to another member. In several alternative embodiments, the lock assembly 4606 may include one or more elements of the locking assemblies disclosed in one or more of the following: (1) PCT patent application serial number PCT/US02/36157, attorney docket number 25791.87.02, filed on 11/12/2002, (2) PCT patent application serial number PCT/US02/36267, attorney docket number 25791.88.02, filed on 11/12/2002, (3) PCT patent application serial number PCT/US03/04837, attorney docket number 25791.95.02, filed on 2/29/2003, (4) PCT patent application serial number PCT/US03/29859, attorney docket no. 25791.102.02, filed on 9/22/2003, (5) PCT patent application serial number PCT/US03/14153, attorney docket number 25791.104.02, filed on 11/13/2003, (6) PCT patent application serial number PCT/US03/18530, attorney docket number 25791.108.02, filed on 6/11/2003, (7) PCT patent application serial number PCT/US03/29858, attorney docket number 25791.112.02, (8) PCT patent application serial number PCT/US03/29460, attorney docket number 25791.114.02, filed on 9/23/2003, filed on 9/22/2003, (9) PCT patent application serial number PCT/US04/07711, attorney docket number 25791.253.02, filed on 3/11/2004, (10) PCT patent application serial number PCT/US2004/009434, attorney docket number 25791.260.02, filed on 3/26/2004, (11) PCT patent application serial number PCT/US2004/010317, attorney docket number 25791.270.02, filed on 4/2/2004, (12) PCT patent application serial number PCT/US2004/010712, attorney docket number 25791.272.02, filed on 4/7/2004, (13) PCT patent application serial number PCT/US2004/010762, attorney docket number 25791.273.02, filed on 4/6/2004, and/or (14) PCT patent application serial number PCT/US2004/011973, attorney docket number 25791.277.02, filed on April 15, 2004, the disclosures of which are incorporated herein by reference.

[00217] A end of a tubular support member 4608 that defines a passage 4608a and includes an outer annular recess 4608b is coupled to another end of the lock assembly 4606, and another end of the tubular support member 4608 is coupled to an end of a tubular support member 4610 that defines a passage 4610a, a radial passage 4610b, and includes an outer annular recess 4610c, an inner annular recess 4610d, and circumferentially spaced apart teeth 4610e at another end.

[00218] An adjustable expansion device assembly 4612 is mounted upon and coupled to the outer annular recess 4610c of the tubular support member 4610. In several exemplary embodiments, the adjustable expansion device assembly 4612 may be a conventional adjustable expansion device assembly for radially expanding and plastically deforming tubular members that may include one or more elements of conventional adjustable expansion cones, mandrels, rotary expansion devices, hydroforming expansion devices and/or one or more elements of the one or more of the commercially available adjustable expansion devices of Enventure Global Technology LLC, Baker Hughes, Weatherford International, and/or Schlumberger and/or one or more elements of the adjustable expansion devices disclosed in one or more of the published patent applications and/or issued patents of Enventure Global Technology LLC, Baker Hughes, Weatherford International, Shell Oil Co. and/or Schlumberger. In several alternative embodiments, the adjustable expansion device assembly 4524 may include one or more elements of the adjustable expansion device assemblies disclosed in one or more of the following: (1) PCT patent application serial number PCT/US02/36157, attorney docket number 25791.87.02, filed on 11/12/2002, (2) PCT patent application serial number PCT/US02/36267, attorney docket number 25791.88.02, filed on 11/12/2002, (3) PCT patent application serial number PCT/US03/04837, attorney docket number 25791.95.02, filed on 2/29/2003, (4) PCT patent application serial number PCT/US03/29859, attorney docket no. 25791.102.02, filed on 9/22/2003, (5) PCT patent application serial number PCT/US03/14153, attorney docket number 25791.104.02, filed on 11/13/2003, (6) PCT patent application serial number PCT/US03/18530, attorney docket number 25791.108.02, filed on 6/11/2003, (7) PCT patent application serial number PCT/US03/29858, attorney docket number 25791.112.02, (8) PCT patent application serial number PCT/US03/29460, attorney docket number 25791.114.02, filed on 9/23/2003, filed on 9/22/2003, (9) PCT patent application serial number PCT/US04/07711, attorney docket number 25791.253.02, filed on 3/11/2004, (10) PCT patent application serial number PCT/US2004/009434, attorney docket number 25791.260.02, filed on 3/26/2004, (11) PCT patent application serial number PCT/US2004/010317, attorney docket number 25791.270.02, filed on 4/2/2004, (12) PCT patent application serial number PCT/US2004/010712, attorney docket number 25791.272.02, filed on 4/7/2004, (13) PCT patent application serial number

PCT/US2004/010762, attorney docket number 25791.273.02, filed on 4/6/2004, and/or (14) PCT patent application serial number PCT/US2004/011973, attorney docket number 25791.277.02, filed on April 15, 2004, the disclosures of which are incorporated herein by reference.

[00219] An end of a float shoe 4614 that defines a passage 4614a having a throat 4614aa and includes a plurality of circumferentially spaced apart teeth 4614b at an end that mate with and engage the teeth 4610e of the tubular support member 4610 for transmitting torsional loads therebetween and an external threaded connection 4614c is received within the inner annular recess 4610d of the tubular support member.

[00220] An end of an expandable tubular member 4616 is coupled to the external threaded connection 4614c of the float shoe 4614 and another portion of the expandable tubular member is coupled to the lock assembly 4606. In an exemplary embodiment, at least a portion of the expandable tubular member 4616 includes one or more of the characteristics of the expandable tubular members described in the present application. In an exemplary embodiment, the portion of the expandable tubular member 4616 proximate and positioned in opposition to the adjustable expansion device assembly 4612 includes an outer expansion limiter sleeve 4618 for limiting the amount of radial expansion of the portion of the expandable tubular member proximate and positioned in opposition to the adjustable expansion device assembly. In an exemplary embodiment, at least a portion of the outer expansion limiter sleeve 4618 includes one or more of the characteristics of the expandable tubular members described in the present application.

[00221] A cup seal assembly 4620 is coupled to and positioned within the outer annular recess 4608b of the tubular support member 4608 for sealingly engaging the interior surface of the expandable tubular member 4616. A rupture disc 4622 is positioned within and coupled to the radial passage 4610b of the tubular support member 4610.

[00222] In an exemplary embodiment, during operation of the system 4600, as illustrated in Fig. 46a, the system is positioned within a wellbore 4624 that traverses a subterranean formation 4626 and includes a preexisting wellbore casing 4628 coupled to and positioned within the wellbore. In an exemplary embodiment, the system 4600 is positioned such that the expandable tubular member 4616 overlaps with the casing 4628.

[00223] Referring to Fig. 46b, in an exemplary embodiment, a plug 4630 is then positioned in the throat passage 4614aa of the float shoe 4614 by injecting fluidic materials 4632 into the system 4600 through the passages 4602a, 4604a, 4606a, 4608a, and 4610a, of the tubular support member 4602, safety sub 4604, lock assembly 4606, tubular support member 4608, and tubular support member 4610, respectively.

[00224] Referring to Fig. 46c, in an exemplary embodiment, the continued injection of the fluidic materials 4632 into the system 4600, following the placement of the plug 4630 in

the throat passage 4614aa, pressurizes the passage 4610a of the tubular support member 4610 such that the rupture disc 4622 is ruptured thereby permitting the fluidic materials to pass through the radial passage 4610b of the tubular support member. As a result, the interior of the expandable tubular member 4616 proximate the adjustable expansion device assembly 4612 is pressurized.

[00225] Referring to Fig. 45d, in an exemplary embodiment, the continued injection of the fluidic materials 4632 into the interior of the expandable tubular member 4616 radially expands and plastically deforms at least a portion of the expandable tubular member. In an exemplary embodiment, the continued injection of the fluidic materials 4632 into the interior of the expandable tubular member 4616 radially expands and plastically deforms a portion of the expandable tubular member positioned in opposition to the adjustable expansion device assembly 4612. In an exemplary embodiment, the continued injection of the fluidic materials 4632 into the interior of the expandable tubular member 4616 radially expands and plastically deforms a portion of the expandable tubular member positioned in opposition to the adjustable expansion device assembly 4612 into engagement with the wellbore casing 4628. In an exemplary embodiment, the transformation of the material properties of the expansion limiter sleeve 4618, during the radial expansion process, limit the extent to which the expandable tubular member 4616 may be radially expanded.

[00226] Referring to Fig. 46e, in an exemplary embodiment, the size of the adjustable expansion device assembly 4612 is then increased within the radially expanded portion of the expandable tubular member 4616, and the lock assembly 4606 is operated to unlock the expandable tubular member from engagement with the lock assembly. In an exemplary embodiment, the lock assembly 4606 and the adjustable expansion device assembly 4612 are operated using the operating pressure provided by the continued injection of the fluidic materials 4632 into the system 4600. In an exemplary embodiment, the adjustment of the adjustable expansion device assembly 4612 to a larger size radially expands and plastically deforms at least a portion of the expandable tubular member 4616.

[00227] Referring to Fig. 46f, in an exemplary embodiment, the adjustable expansion device assembly 4612 is displaced in a longitudinal direction relative to the expandable tubular member 4616 thereby radially expanding and plastically deforming the expandable tubular member. In an exemplary embodiment, the expandable tubular member 4616 is radially expanded and plastically deformed into engagement with the casing 4628. In an exemplary embodiment, the adjustable expansion device assembly 4612 is displaced in a longitudinal direction relative to the expandable tubular member 4616 due to the operating pressure within the expandable tubular member generated by the continued injection of the fluidic materials 4632.

[00228] In several alternative embodiments, during the operation of the system 4600, a hardenable fluidic sealing material such as, for example, cement, may be injected through the system 4600 before, during or after the radial expansion of the expandable tubular member 4616 in order to form an annular barrier between the wellbore 4624 and/or the wellbore casing 4628 and the expandable tubular member.

[00229] In several alternative embodiments, during the operation of the system 4600, the size of the adjustable expansion device 4612 is increased prior to, during, or after the hydroforming expansion of the expandable tubular member 4616 caused by the injection of the fluidic materials 4632 into the interior of the expandable tubular member.

[00230] In several alternative embodiments, at least a portion of the expandable tubular member 4616 includes a plurality of nested expandable tubular members bonded together by, for example, amorphous bonding.

[00231] In several alternative embodiments, at least a portion of the expandable tubular member 4616 is fabricated for materials particularly suited for subsequent drilling out operations such as, for example, aluminum and/or copper based materials and alloys.

[00232] In several alternative embodiments, during the operation of the system 4600, the portion of the expandable tubular member 4616 positioned below the adjustable expansion device 4612 is radially expanded and plastically deformed by displacing the adjustable expansion device downwardly.

[00233] In several alternative embodiments, at least a portion of the expandable tubular member 4616 is fabricated for materials particularly suited for subsequent drilling out operations such as, for example, aluminum and/or copper based materials and alloys. In several alternative embodiments, during the operation of the system 4600, the portion of the expandable tubular member 4616 fabricated for materials particularly suited for subsequent drilling out operations is not hydroformed by the injection of the fluidic materials 4632.

[00234] In several alternative embodiments, during the operation of the system 4600, at least a portion of the expandable tubular member 4616 is hydroformed by the injection of the fluidic materials 4632, the remaining portion of the expandable tubular member above the initial position of the adjustable expansion device 4612 is then radially expanded and plastically deformed by displacing the adjustable expansion device upwardly, and the portion of the expandable tubular member below the initial position of the adjustable expansion device is radially expanded by then displacing the adjustable expansion device downwardly.

[00235] In several alternative embodiments, during the operation of the system 4600, the portion of the expandable tubular member 4616 that is radially expanded and plastically deformed is radially expanded and plastically deformed solely by hydroforming caused by the injection of the fluidic materials 4632.

[00236] In several alternative embodiments, during the operation of the system 4600, the portion of the expandable tubular member 4616 that is radially expanded and plastically deformed is radially expanded and plastically deformed solely by the adjustment of the adjustable expansion device 4612 to an increased size and the subsequent displacement of the adjustable expansion device relative to the expandable tubular member.

[00237] In an exemplary experimental embodiment, expandable tubular members fabricated from tellurium copper, leaded naval brass, phosphorous bronze, and aluminum-silicon bronze were successfully hydroformed and thereby radially expanded and plastically deformed by up to about 30% radial expansion, all of which were unexpected results.

[00238] Referring to Fig. 46g, in an exemplary embodiment, at least a portion of the expansion limiter sleeve 4618, prior to the radial expansion and plastic deformation of the expansion limiter sleeve by operation of the system 4600, includes one or more diamond shaped slots 4618a. Referring to Fig. 46h, in an exemplary embodiment, during the radial expansion and plastic deformation of the expansion limiter sleeve by operation of the system 4600, the diamond shaped slots 4618a are deformed such that further radial expansion of the expansion limiter sleeve requires increased force. More generally, the expansion limiter sleeve 4618 may be manufactured with slots whose cross sectional areas are decreased by the radial expansion and plastic deformation of the expansion limited sleeve thereby increasing the amount of force required to further radially expand the expansion limiter sleeve. In this manner, the extent to which the expandable tubular member 4616 may be radially expanded is limited. In several alternative embodiments, at least a portion of the expandable tubular member 4616 includes slots whose cross sectional areas are decreased by the radial expansion and plastic deformation of the expandable tubular member thereby increasing the amount of force required to further radially expand the expandable tubular member.

[00239] Referring to Figs. 46i and 46ia, in an exemplary embodiment, at least a portion of the expansion limiter sleeve 4618, prior to the radial expansion and plastic deformation of the expansion limiter sleeve by operation of the system 4600, includes one or more wavy circumferentially oriented spaced apart bands 4618b. Referring to Fig. 46j, in an exemplary embodiment, during the radial expansion and plastic deformation of the expansion limiter sleeve by operation of the system 4600, the bands 4618b are deformed such that the further radial expansion of the expansion limiter sleeve requires added force. More generally, the expansion limiter sleeve 4618 may be manufactured with a circumferential bands whose orientation becomes more and more aligned with a direction that is orthogonal to the longitudinal axis of the sectional areas as a result of the radial expansion and plastic deformation of the bands thereby increasing the amount of force required to further radially expand the expansion limiter sleeve. In this manner, the extent to

which the expandable tubular member 4616 may be radially expanded is limited. In several alternative embodiments, at least a portion of the expandable tubular member 4616 includes circumferential bands whose orientation becomes more and more aligned with a direction that is orthogonal to the longitudinal axis of the sectional areas as a result of the radial expansion and plastic deformation of the bands thereby increasing the amount of force required to further radially expand the expandable tubular member.

[00240] In several exemplary embodiments, the design of the expansion limiter sleeve 4618 provides a restraining force that limits the extent to which the expandable tubular member 4616 may be radially expanded and plastically deformed. Furthermore, in several exemplary embodiments, the design of the expansion limiter sleeve 4618 provides a variable restraining force that limits the extent to which the expandable tubular member 4616 may be radially expanded and plastically deformed. In several exemplary embodiments, the variable restraining force of the expansion limiter sleeve 4618 increases in proportion to the degree to which the expandable tubular member 4616 has been radially expanded.

[00241] A method of radially expanding a tubular assembly has been described that includes radially expanding and plastically deforming a lower portion of the tubular assembly by pressurizing the interior of the lower portion of the tubular assembly; and then, radially expanding and plastically deforming the remaining portion of the tubular assembly by contacting the interior of the tubular assembly with an expansion device. In an exemplary embodiment, the expansion device is an adjustable expansion device. In an exemplary embodiment, the expansion device is a hydroforming expansion device. In an exemplary embodiment, the expansion device is a rotary expansion device. In an exemplary embodiment, the lower portion of the tubular assembly has a higher ductility and a lower yield point prior to the radial expansion and plastic deformation than after the radial expansion and plastic deformation. In an exemplary embodiment, the remaining portion of the tubular assembly has a higher ductility and a lower yield point prior to the radial expansion and plastic deformation than after the radial expansion and plastic deformation. In an exemplary embodiment, the lower portion of the tubular assembly includes a shoe defining a valveable passage.

[00242] A system for radially expanding a tubular assembly has been described that includes means for radially expanding and plastically deforming a lower portion of the tubular assembly by pressurizing the interior of the lower portion of the tubular assembly; and then, means for radially expanding and plastically deforming the remaining portion of the tubular assembly by contacting the interior of the tubular assembly with an expansion device. In an exemplary embodiment, the lower portion of the tubular assembly has a higher ductility and a lower yield point prior to the radial expansion and plastic deformation than after the radial expansion and plastic deformation. In an exemplary embodiment, the remaining portion of

the tubular assembly has a higher ductility and a lower yield point prior to the radial expansion and plastic deformation than after the radial expansion and plastic deformation.

[00243] A method of repairing a tubular assembly has been described that includes positioning a tubular patch within the tubular assembly; and radially expanding and plastically deforming a tubular patch into engagement with the tubular assembly by pressurizing the interior of the tubular patch. In an exemplary embodiment, the tubular patch has a higher ductility and a lower yield point prior to the radial expansion and plastic deformation than after the radial expansion and plastic deformation.

[00244] A method of radially expanding a tubular member has been described that includes accumulating a supply of pressurized fluid; and controllably injecting the pressurized fluid into the interior of the tubular member. In an exemplary embodiment, accumulating the supply of pressurized fluid includes: monitoring the operating pressure of the accumulated fluid; and if the operating pressure of the accumulated fluid is less than a predetermined amount, injecting pressurized fluid into the accumulated fluid. In an exemplary embodiment, controllably injecting the pressurized fluid into the interior of the tubular member includes: monitoring the operating condition of the tubular member; and if the tubular member has been radial expanded, releasing the pressurized fluid from the interior of the tubular member.

[00245] A system for radially expanding a tubular member has been described that includes means for accumulating a supply of pressurized fluid; and means for controllably injecting the pressurized fluid into the interior of the tubular member. In an exemplary embodiment, means for accumulating the supply of pressurized fluid includes: means for monitoring the operating pressure of the accumulated fluid; and if the operating pressure of the accumulated fluid is less than a predetermined amount, means for injecting pressurized fluid into the accumulated fluid. In an exemplary embodiment, means for controllably injecting the pressurized fluid into the interior of the tubular member includes: means for monitoring the operating condition of the tubular member; and if the tubular member has been radial expanded, means for releasing the pressurized fluid from the interior of the tubular member.

[00246] An apparatus for radially expanding a tubular member has been described that includes a fluid reservoir; a pump for pumping fluids out of the fluid reservoir; an accumulator for receiving and accumulating the fluids pumped from the reservoir; a flow control valve for controllably releasing the fluids accumulated within the reservoir; and an expansion element for engaging the interior of the tubular member to define a pressure chamber within the tubular member and receiving the released accumulated fluids into the pressure chamber.

[00247] A method for radially expanding a tubular member has been described that includes positioning a tubular member and an adjustable expansion device within a preexisting structure; radially expanding and plastically deforming at least a portion of the tubular member by pressurizing an interior portion of the tubular member; increasing the size of the adjustable expansion device; and radially expanding and plastically deforming another portion of the tubular member by displacing the adjustable expansion device relative to the tubular member. In an exemplary embodiment, the method further includes sensing an operating pressure within the tubular member. In an exemplary embodiment, wherein radially expanding and plastically deforming at least a portion of the tubular member by pressurizing an interior portion of the tubular member includes: injecting fluidic material into the tubular member; sensing the operating pressure of the injected fluidic material; and if the operating pressure of the injected fluidic material exceeds a predetermined value, permitting the fluidic material to enter a pressure chamber defined within the tubular member. In an exemplary embodiment, at least a portion of the tubular member has a higher ductility and a lower yield point prior to the radial expansion and plastic deformation than after the radial expansion and plastic deformation. In an exemplary embodiment, the portion of the tubular member comprises the pressurized portion of the tubular member.

[00248] A system for radially expanding a tubular member has been described that includes means for positioning a tubular member and an adjustable expansion device within a preexisting structure; means for radially expanding and plastically deforming at least a portion of the tubular member by pressurizing an interior portion of the tubular member; means for increasing the size of the adjustable expansion device; and means for radially expanding and plastically deforming another portion of the tubular member by displacing the adjustable expansion device relative to the tubular member. In an exemplary embodiment, the system further includes: sensing an operating pressure within the tubular member. In an exemplary embodiment, radially expanding and plastically deforming at least a portion of the tubular member by pressurizing an interior portion of the tubular member includes: injecting fluidic material into the tubular member; sensing the operating pressure of the injected fluidic material; and if the operating pressure of the injected fluidic material exceeds a predetermined value, permitting the fluidic material to enter a pressure chamber defined within the tubular member. In an exemplary embodiment, at least a portion of the tubular member has a higher ductility and a lower yield point prior to the radial expansion and plastic deformation than after the radial expansion and plastic deformation. In an exemplary embodiment, the portion of the tubular member includes the pressurized portion of the tubular member.

[00249] An apparatus for radially expanding a tubular member has been described that includes: an expandable tubular member; an expansion device coupled to the

expandable tubular member for radially expanding and plastically deforming the expandable tubular member; an tubular expansion limiter coupled to the expandable tubular member for limiting the degree to which the expandable tubular member may be radially expanded and plastically deformed; a locking device positioned within the expandable tubular member releasably coupled to the expandable tubular member; a tubular support member positioned within the expandable tubular member coupled to the locking device and the expansion device; means for transmitting torque between the expandable tubular member and the tubular support member; means for sealing the interface between the expandable tubular member and the tubular support member; means for sensing the operating pressure within the tubular support member; and means for pressurizing the interior of the tubular support member; wherein at least a portion of the expandable tubular member has a higher ductility and a lower yield point prior to the radial expansion and plastic deformation than after the radial expansion and plastic deformation.

[00250] A method for radially expanding a tubular member has been described that includes positioning a tubular member and an adjustable expansion device within a preexisting structure; radially expanding and plastically deforming at least a portion of the tubular member by pressurizing an interior portion of the tubular member; limiting the extent to which the portion of the tubular member is radially expanded and plastically deformed by pressurizing the interior of the tubular member; increasing the size of the adjustable expansion device; and radially expanding and plastically deforming another portion of the tubular member by displacing the adjustable expansion device relative to the tubular member. In an exemplary embodiment, the method further includes sensing an operating pressure within the tubular member. In an exemplary embodiment, radially expanding and plastically deforming at least a portion of the tubular member by pressurizing an interior portion of the tubular member includes: injecting fluidic material into the tubular member; sensing the operating pressure of the injected fluidic material; and if the operating pressure of the injected fluidic material exceeds a predetermined value, permitting the fluidic material to enter a pressure chamber defined within the tubular member. In an exemplary embodiment, at least a portion of the tubular member has a higher ductility and a lower yield point prior to the radial expansion and plastic deformation than after the radial expansion and plastic deformation. In an exemplary embodiment, limiting the extent to which the portion of the tubular member is radially expanded and plastically deformed by pressurizing the interior of the tubular member includes: applying a force to the exterior of the tubular member. In an exemplary embodiment, applying a force to the exterior of the tubular member includes: applying a variable force to the exterior of the tubular member.

[00251] A system for radially expanding a tubular member has been described that includes means for positioning a tubular member and an adjustable expansion device within

a preexisting structure; means for radially expanding and plastically deforming at least a portion of the tubular member by pressurizing an interior portion of the tubular member; means for limiting the extent to which the portion of the tubular member is radially expanded and plastically deformed by pressurizing the interior of the tubular member; means for increasing the size of the adjustable expansion device; and means for radially expanding and plastically deforming another portion of the tubular member by displacing the adjustable expansion device relative to the tubular member. In an exemplary embodiment, the method further includes: means for sensing an operating pressure within the tubular member. In an exemplary embodiment, means for radially expanding and plastically deforming at least a portion of the tubular member by pressurizing an interior portion of the tubular member includes: means for injecting fluidic material into the tubular member; means for sensing the operating pressure of the injected fluidic material; and if the operating pressure of the injected fluidic material exceeds a predetermined value, means for permitting the fluidic material to enter a pressure chamber defined within the tubular member. In an exemplary embodiment, at least a portion of the tubular member has a higher ductility and a lower yield point prior to the radial expansion and plastic deformation than after the radial expansion and plastic deformation. In an exemplary embodiment, means for limiting the extent to which the portion of the tubular member is radially expanded and plastically deformed by pressurizing the interior of the tubular member includes: means for applying a force to the exterior of the tubular member. In an exemplary embodiment, wherein means for applying a force to the exterior of the tubular member includes: means for applying a variable force to the exterior of the tubular member.

[00252] It is understood that variations may be made in the foregoing without departing from the scope of the invention. For example, the teachings of the present illustrative embodiments may be used to provide a wellbore casing, a pipeline, or a structural support. Furthermore, the elements and teachings of the various illustrative embodiments may be combined in whole or in part in some or all of the illustrative embodiments. In addition, one or more of the elements and teachings of the various illustrative embodiments may be omitted, at least in part, and/or combined, at least in part, with one or more of the other elements and teachings of the various illustrative embodiments.

[00253] Although illustrative embodiments of the invention have been shown and described, a wide range of modification, changes and substitution is contemplated in the foregoing disclosure. In some instances, some features of the present invention may be employed without a corresponding use of the other features. Accordingly, it is appropriate that the appended claims be construed broadly and in a manner consistent with the scope of the invention.

What is claimed is:

1. A method of radially expanding a tubular assembly, comprising:
radially expanding and plastically deforming a lower portion of the tubular assembly by pressurizing the interior of the lower portion of the tubular assembly; and then, radially expanding and plastically deforming the remaining portion of the tubular assembly by contacting the interior of the tubular assembly with an expansion device.
2. The method of claim 1, wherein the expansion device comprises an adjustable expansion device.
3. The method of claim 1, wherein the expansion device comprises a hydroforming expansion device.
4. The method of claim 1, wherein the expansion device comprises a rotary expansion device.
5. The method of claim 1, wherein the lower portion of the tubular assembly has a higher ductility and a lower yield point prior to the radial expansion and plastic deformation than after the radial expansion and plastic deformation.
6. The method of claim 5, wherein the remaining portion of the tubular assembly has a higher ductility and a lower yield point prior to the radial expansion and plastic deformation than after the radial expansion and plastic deformation.
7. The method of claim 1, wherein the lower portion of the tubular assembly comprises a shoe defining a valveable passage.
8. A system for radially expanding a tubular assembly, comprising:
means for radially expanding and plastically deforming a lower portion of the tubular assembly by pressurizing the interior of the lower portion of the tubular assembly; and
then, means for radially expanding and plastically deforming the remaining portion of the tubular assembly by contacting the interior of the tubular assembly with an expansion device.

9. The system of claim 8, wherein the lower portion of the tubular assembly has a higher ductility and a lower yield point prior to the radial expansion and plastic deformation than after the radial expansion and plastic deformation.
10. The system of claim 9, wherein the remaining portion of the tubular assembly has a higher ductility and a lower yield point prior to the radial expansion and plastic deformation than after the radial expansion and plastic deformation.
11. A method of repairing a tubular assembly, comprising:
 - positioning a tubular patch within the tubular assembly; and
 - radially expanding and plastically deforming a tubular patch into engagement with the tubular assembly by pressurizing the interior of the tubular patch.
12. The method of claim 11, wherein the tubular patch has a higher ductility and a lower yield point prior to the radial expansion and plastic deformation than after the radial expansion and plastic deformation.
13. A method of radially expanding a tubular member, comprising:
 - accumulating a supply of pressurized fluid; and
 - controllably injecting the pressurized fluid into the interior of the tubular member.
14. The method of claim 13, wherein accumulating the supply of pressurized fluid comprises:
 - monitoring the operating pressure of the accumulated fluid; and
 - if the operating pressure of the accumulated fluid is less than a predetermined amount, injecting pressurized fluid into the accumulated fluid.
15. The method of claim 13, wherein controllably injecting the pressurized fluid into the interior of the tubular member comprises:
 - monitoring the operating condition of the tubular member; and
 - if the tubular member has been radial expanded, releasing the pressurized fluid from the interior of the tubular member.
16. An apparatus for radially expanding a tubular member, comprising:
 - a fluid reservoir;
 - a pump for pumping fluids out of the fluid reservoir;
 - an accumulator for receiving and accumulating the fluids pumped from the reservoir;

- a flow control valve for controllably releasing the fluids accumulated within the reservoir; and
- an expansion element for engaging the interior of the tubular member to define a pressure chamber within the tubular member and receiving the released accumulated fluids into the pressure chamber.
17. A method for radially expanding a tubular member, comprising:
 - positioning a tubular member and an adjustable expansion device within a preexisting structure;
 - radially expanding and plastically deforming at least a portion of the tubular member by pressurizing an interior portion of the tubular member;
 - increasing the size of the adjustable expansion device; and
 - radially expanding and plastically deforming another portion of the tubular member by displacing the adjustable expansion device relative to the tubular member.
 18. The method of claim 17, further comprising:
 - sensing an operating pressure within the tubular member.
 19. The method of claim 17, wherein radially expanding and plastically deforming at least a portion of the tubular member by pressurizing an interior portion of the tubular member comprises:
 - injecting fluidic material into the tubular member;
 - sensing the operating pressure of the injected fluidic material; and
 - if the operating pressure of the injected fluidic material exceeds a predetermined value, permitting the fluidic material to enter a pressure chamber defined within the tubular member.
 20. The method of claim 17, wherein at least a portion of the tubular member has a higher ductility and a lower yield point prior to the radial expansion and plastic deformation than after the radial expansion and plastic deformation.
 21. The method of claim 17, wherein the portion of the tubular member comprises the pressurized portion of the tubular member.
 22. A system for radially expanding a tubular member, comprising:
 - means for positioning a tubular member and an adjustable expansion device within a preexisting structure;

means for radially expanding and plastically deforming at least a portion of the tubular member by pressurizing an interior portion of the tubular member;
means for increasing the size of the adjustable expansion device; and
means for radially expanding and plastically deforming another portion of the tubular member by displacing the adjustable expansion device relative to the tubular member.

23. The system of claim 22, further comprising:
sensing an operating pressure within the tubular member.
24. The system of claim 22, wherein radially expanding and plastically deforming at least a portion of the tubular member by pressurizing an interior portion of the tubular member comprises:
injecting fluidic material into the tubular member;
sensing the operating pressure of the injected fluidic material; and
if the operating pressure of the injected fluidic material exceeds a predetermined value, permitting the fluidic material to enter a pressure chamber defined within the tubular member.
25. The system of claim 22, wherein at least a portion of the tubular member has a higher ductility and a lower yield point prior to the radial expansion and plastic deformation than after the radial expansion and plastic deformation.
26. The system of claim 22, wherein the portion of the tubular member comprises the pressurized portion of the tubular member.
27. An apparatus for radially expanding a tubular member, comprising:
an expandable tubular member;
an expansion device coupled to the expandable tubular member for radially expanding and plastically deforming the expandable tubular member;
an tubular expansion limiter coupled to the expandable tubular member for limiting the degree to which the expandable tubular member may be radially expanded and plastically deformed;
a locking device positioned within the expandable tubular member releasably coupled to the expandable tubular member;
a tubular support member positioned within the expandable tubular member coupled to the locking device and the expansion device;

- means for transmitting torque between the expandable tubular member and the tubular support member;
- means for sealing the interface between the expandable tubular member and the tubular support member;
- means for sensing the operating pressure within the tubular support member; and
- means for pressurizing the interior of the tubular support member;
- wherein at least a portion of the expandable tubular member has a higher ductility and a lower yield point prior to the radial expansion and plastic deformation than after the radial expansion and plastic deformation.
28. A method for radially expanding a tubular member, comprising:
- positioning a tubular member and an adjustable expansion device within a preexisting structure;
 - radially expanding and plastically deforming at least a portion of the tubular member by pressurizing an interior portion of the tubular member;
 - limiting the extent to which the portion of the tubular member is radially expanded and plastically deformed by pressurizing the interior of the tubular member;
 - increasing the size of the adjustable expansion device; and
 - radially expanding and plastically deforming another portion of the tubular member by displacing the adjustable expansion device relative to the tubular member.
29. The method of claim 28, further comprising:
- sensing an operating pressure within the tubular member.
30. The method of claim 28, wherein radially expanding and plastically deforming at least a portion of the tubular member by pressurizing an interior portion of the tubular member comprises:
- injecting fluidic material into the tubular member;
 - sensing the operating pressure of the injected fluidic material; and
 - if the operating pressure of the injected fluidic material exceeds a predetermined value, permitting the fluidic material to enter a pressure chamber defined within the tubular member.
31. The method of claim 28, wherein at least a portion of the tubular member has a higher ductility and a lower yield point prior to the radial expansion and plastic deformation than after the radial expansion and plastic deformation.

32. The method of claim 28, wherein limiting the extent to which the portion of the tubular member is radially expanded and plastically deformed by pressurizing the interior of the tubular member comprises:
applying a force to the exterior of the tubular member.
33. The method of claim 32, wherein applying a force to the exterior of the tubular member comprises:
applying a variable force to the exterior of the tubular member.
34. A system for radially expanding a tubular member, comprising:
means for positioning a tubular member and an adjustable expansion device within a preexisting structure;
means for radially expanding and plastically deforming at least a portion of the tubular member by pressurizing an interior portion of the tubular member;
means for limiting the extent to which the portion of the tubular member is radially expanded and plastically deformed by pressurizing the interior of the tubular member;
means for increasing the size of the adjustable expansion device; and
means for radially expanding and plastically deforming another portion of the tubular member by displacing the adjustable expansion device relative to the tubular member.
35. The method of claim 34, further comprising:
means for sensing an operating pressure within the tubular member.
36. The method of claim 34, wherein means for radially expanding and plastically deforming at least a portion of the tubular member by pressurizing an interior portion of the tubular member comprises:
means for injecting fluidic material into the tubular member;
means for sensing the operating pressure of the injected fluidic material; and
if the operating pressure of the injected fluidic material exceeds a predetermined value, means for permitting the fluidic material to enter a pressure chamber defined within the tubular member.
37. The method of claim 34, wherein at least a portion of the tubular member has a higher ductility and a lower yield point prior to the radial expansion and plastic deformation than after the radial expansion and plastic deformation.

38. The method of claim 34, wherein means for limiting the extent to which the portion of the tubular member is radially expanded and plastically deformed by pressurizing the interior of the tubular member comprises:
means for applying a force to the exterior of the tubular member.
39. The method of claim 32, wherein means for applying a force to the exterior of the tubular member comprises:
means for applying a variable force to the exterior of the tubular member.
40. A system for radially expanding a tubular member, comprising:
means for accumulating a supply of pressurized fluid; and
means for controllably injecting the pressurized fluid into the interior of the tubular member.
41. The system of claim 40, wherein means for accumulating the supply of pressurized fluid comprises:
means for monitoring the operating pressure of the accumulated fluid; and
if the operating pressure of the accumulated fluid is less than a predetermined amount, means for injecting pressurized fluid into the accumulated fluid.
42. The system of claim 40, wherein means for controllably injecting the pressurized fluid into the interior of the tubular member comprises:
means for monitoring the operating condition of the tubular member; and
if the tubular member has been radial expanded, means for releasing the pressurized fluid from the interior of the tubular member.

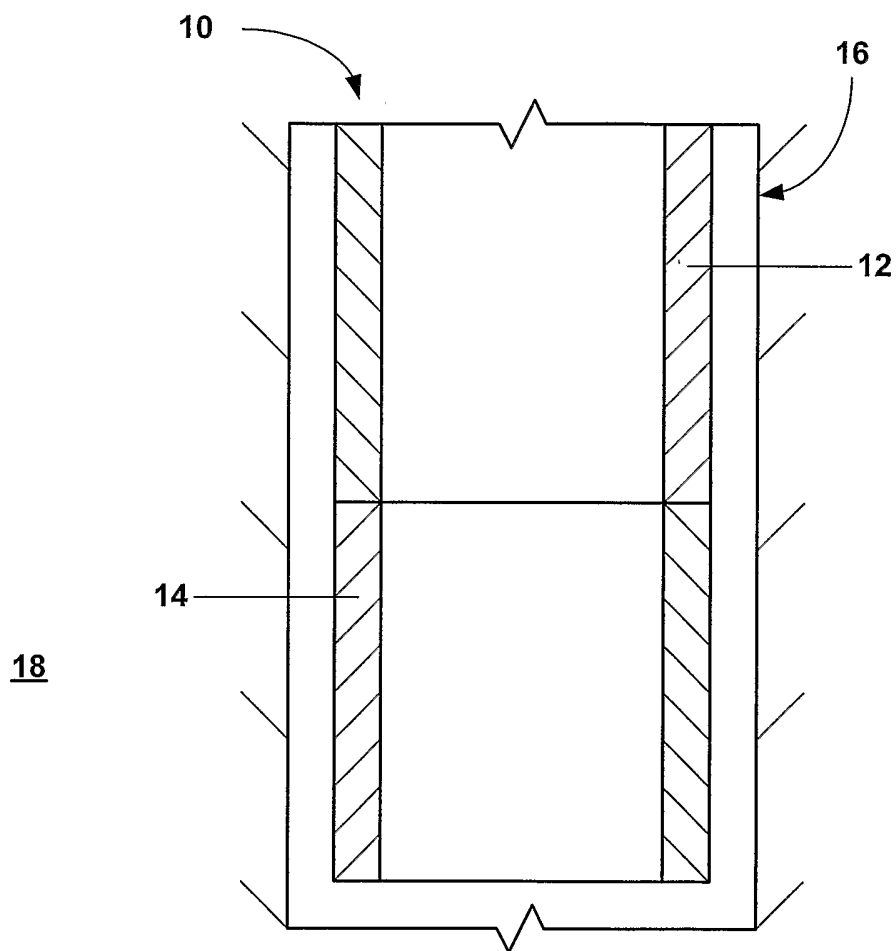

FIG. 1

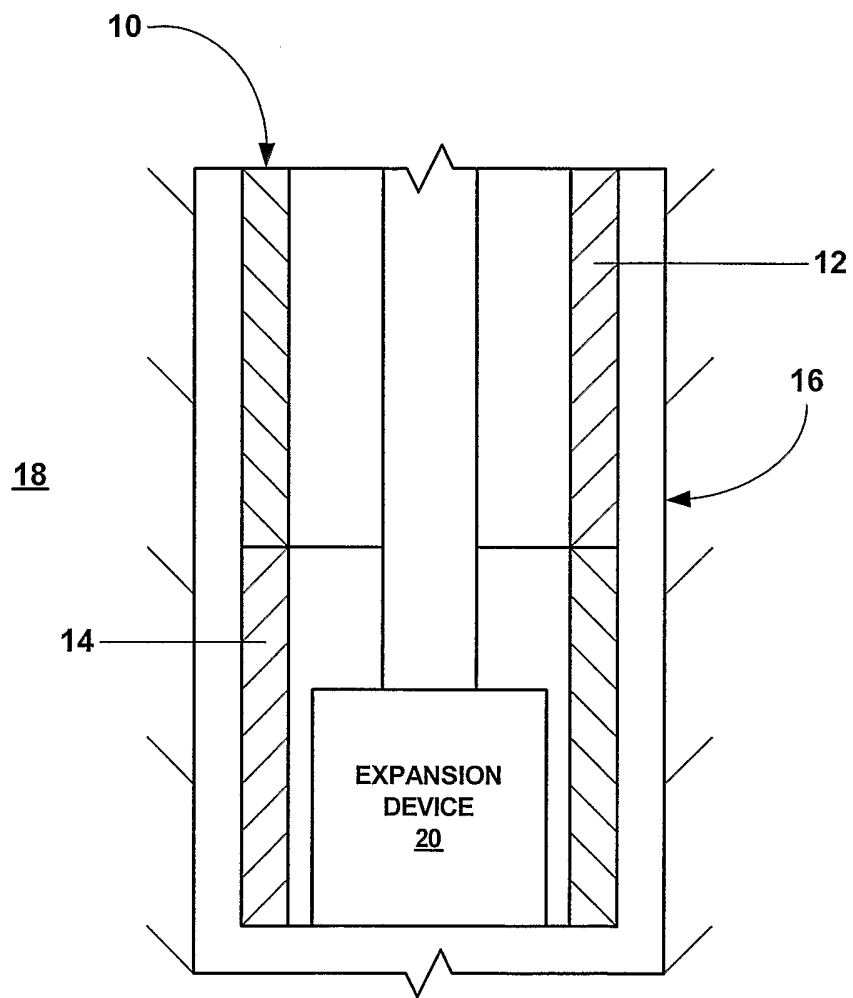

FIG. 2

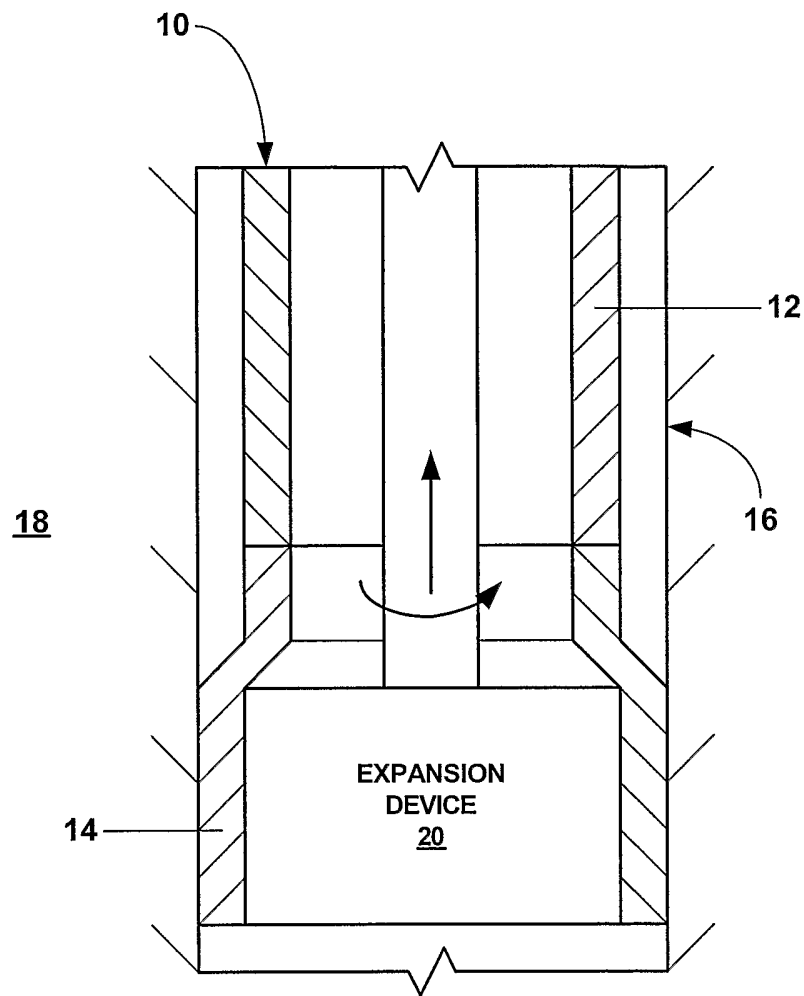

FIG. 3

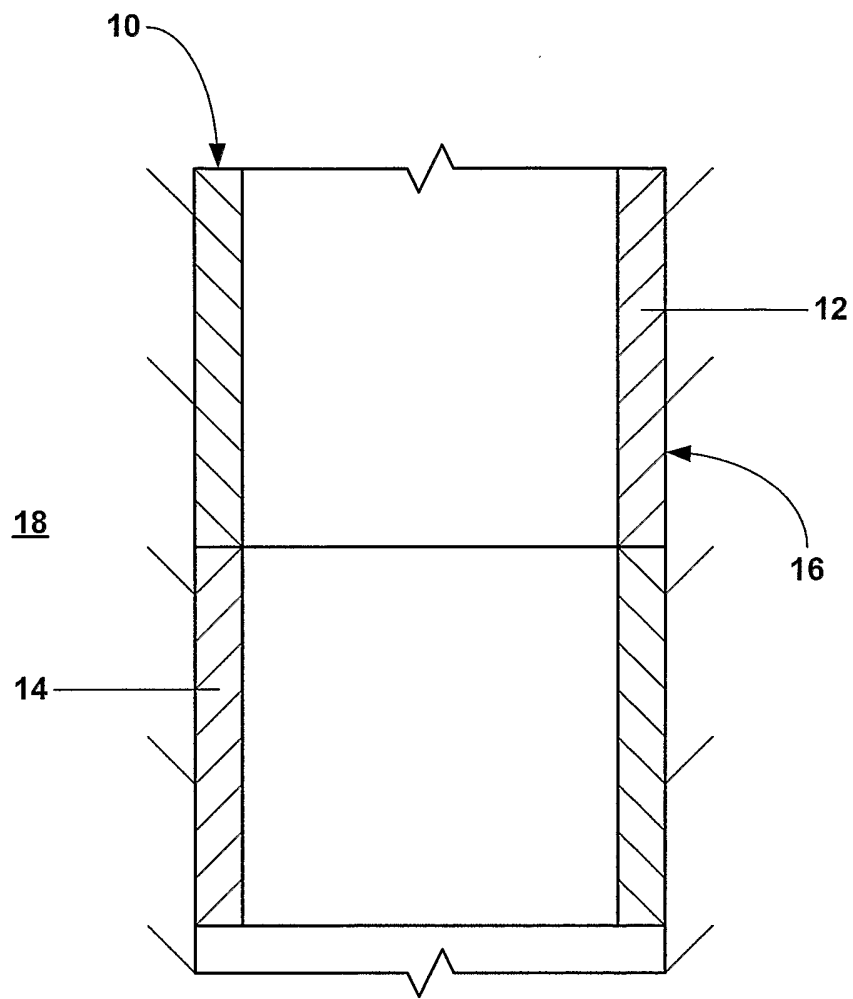

FIG. 4

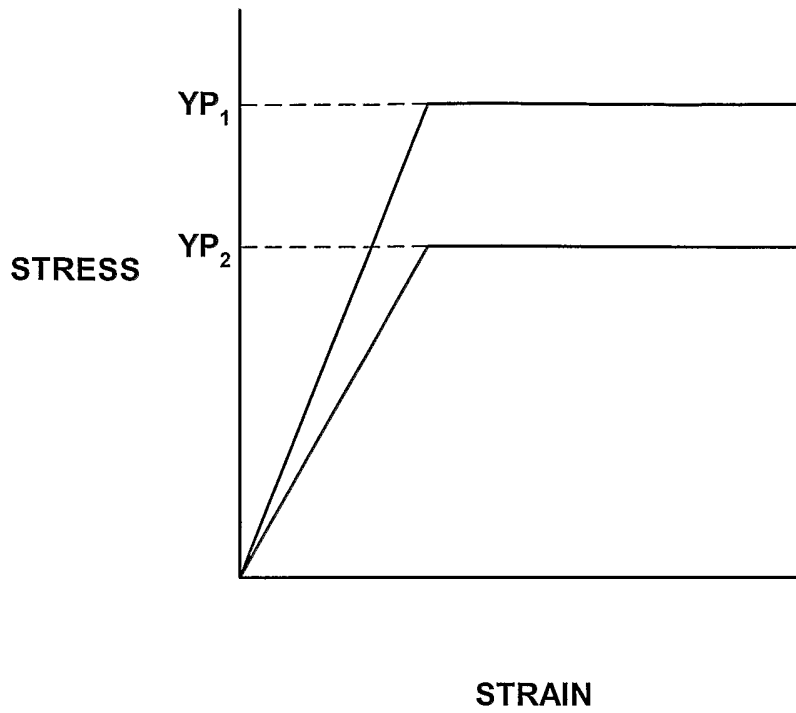

FIG. 5

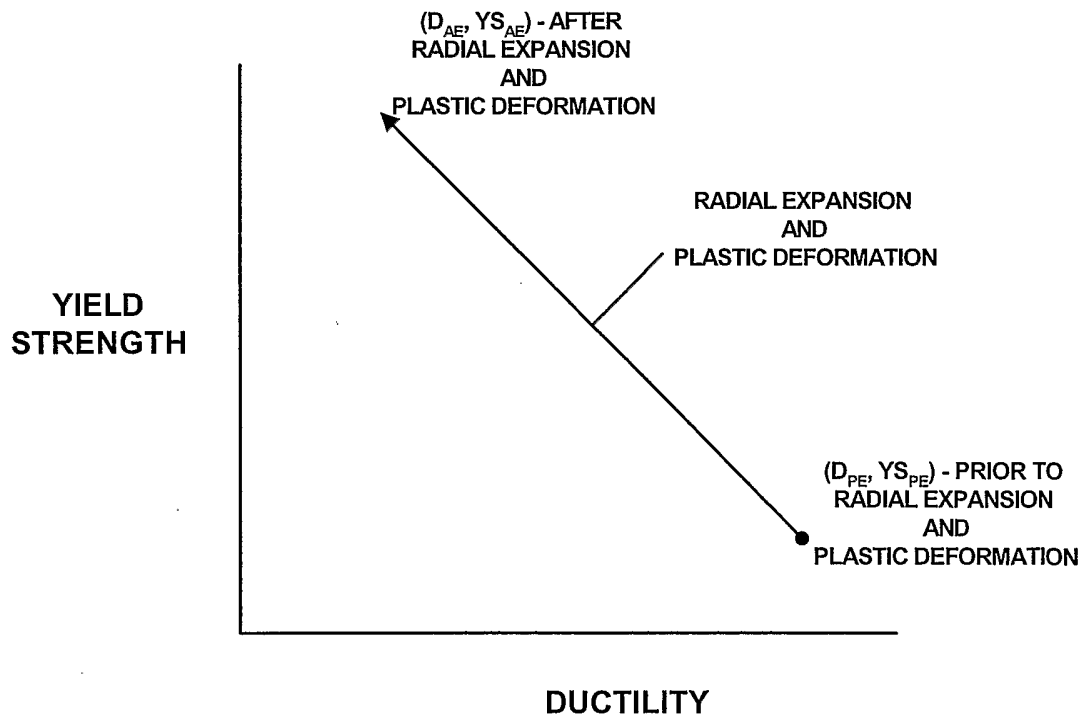

FIG. 6

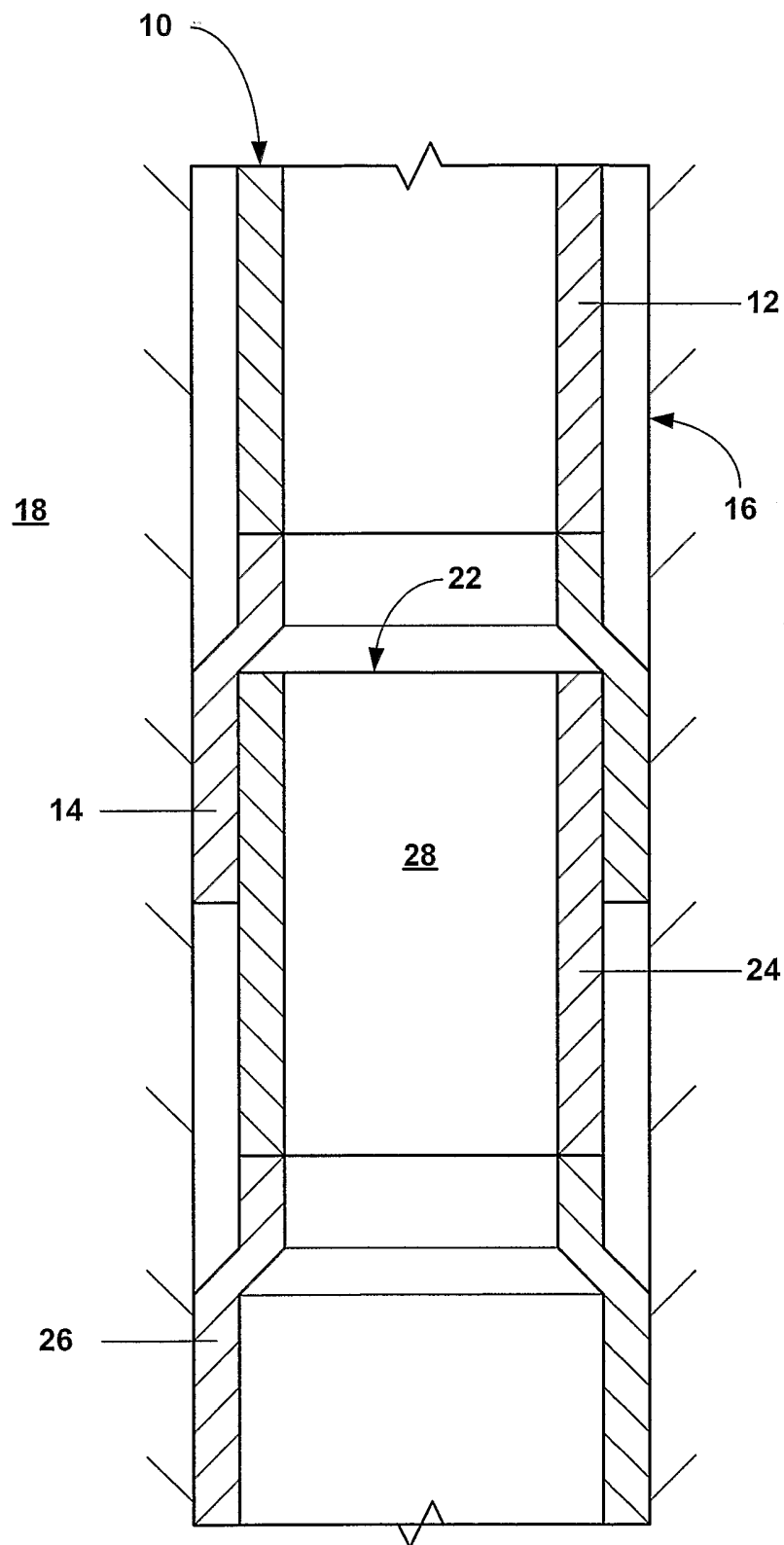

FIG. 7

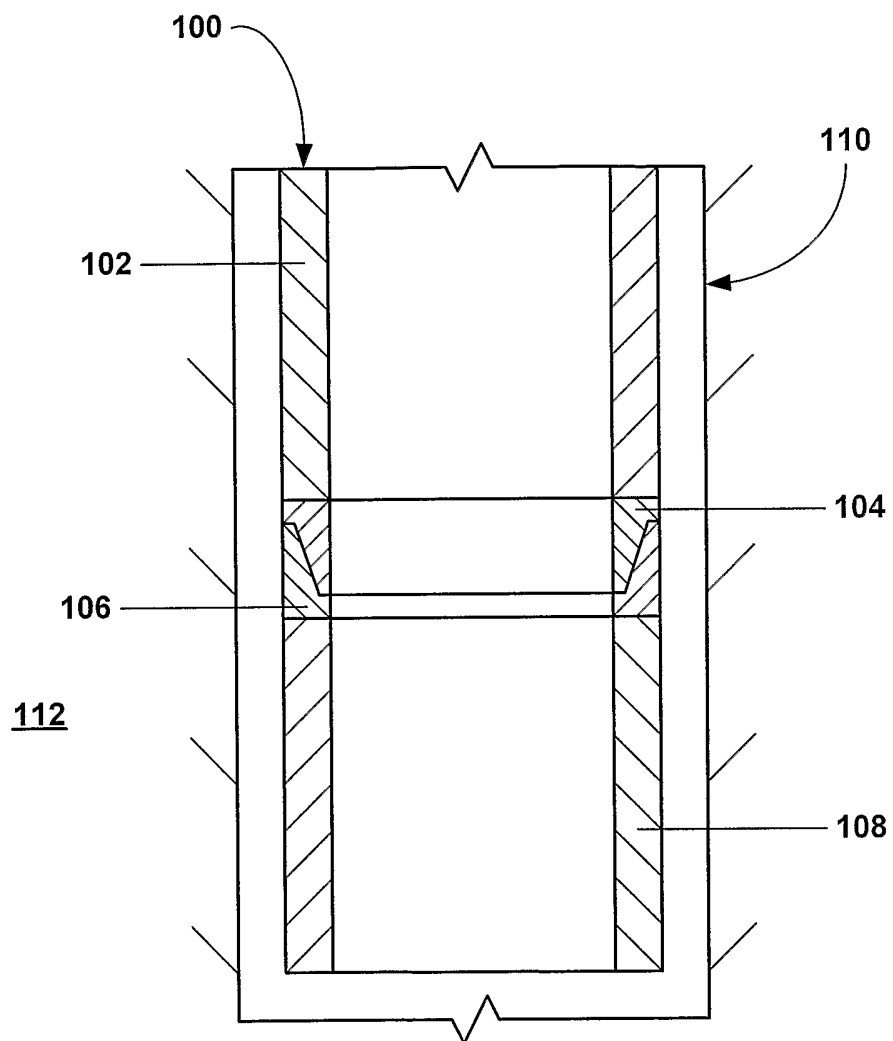

FIG. 8

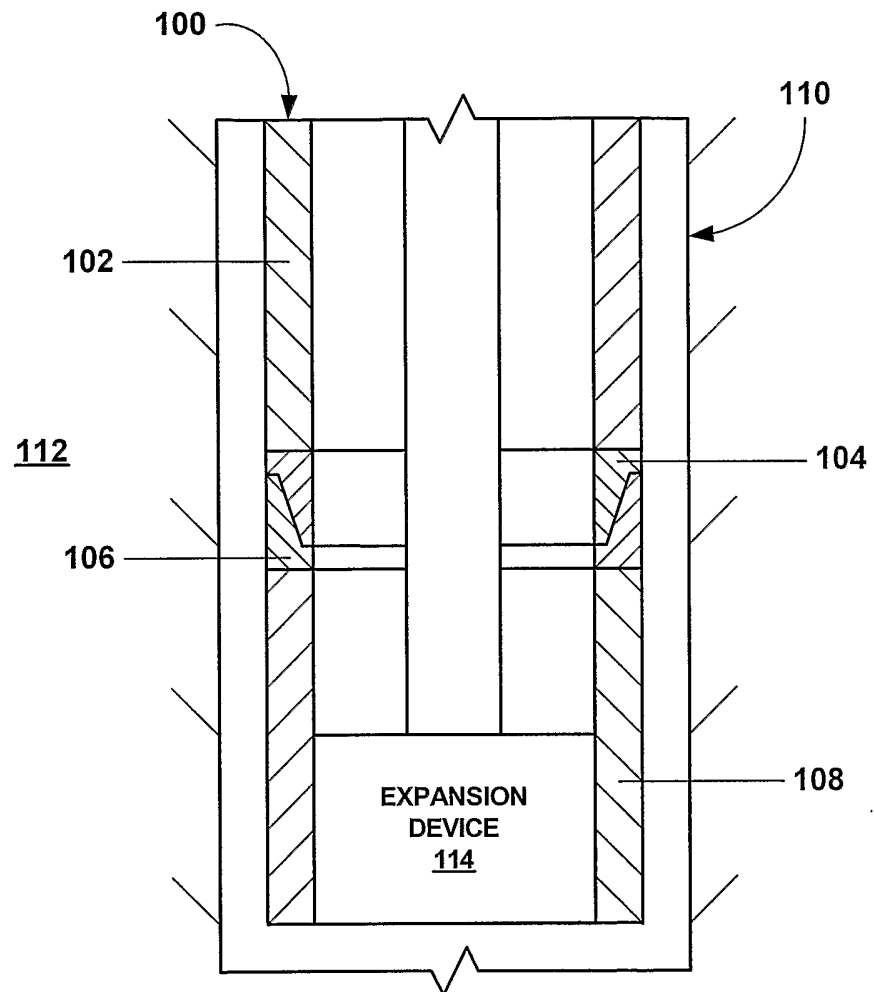

FIG. 9

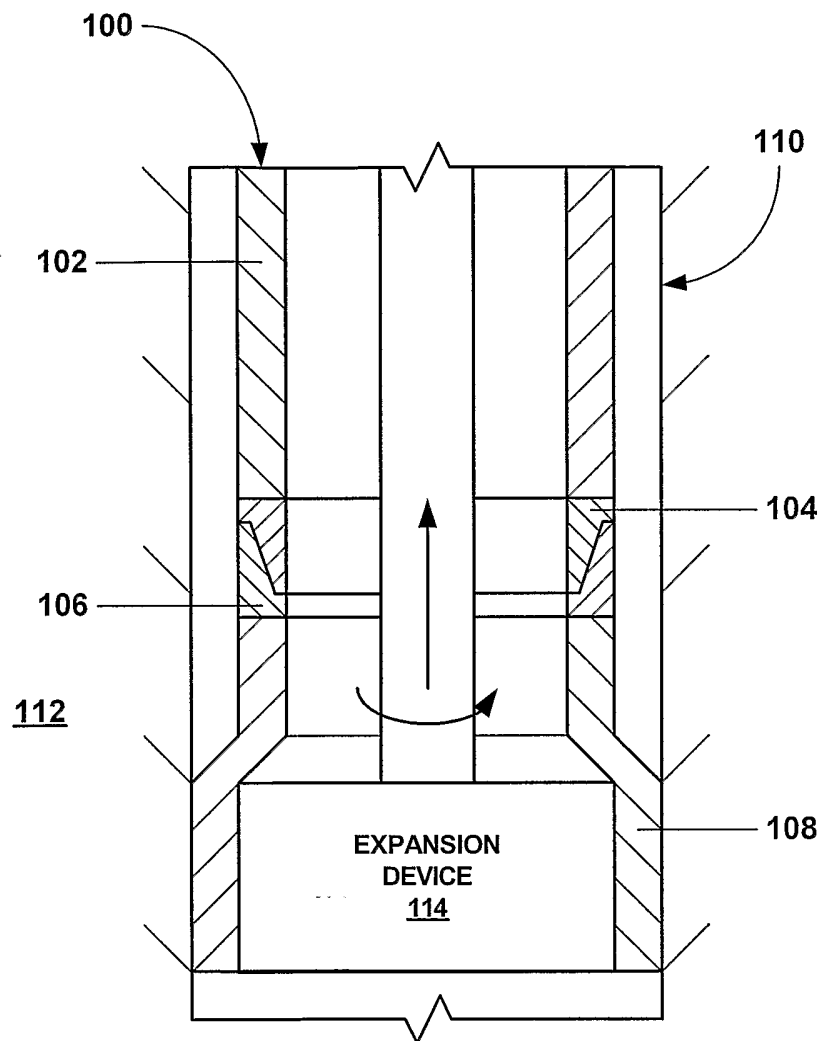

FIG. 10

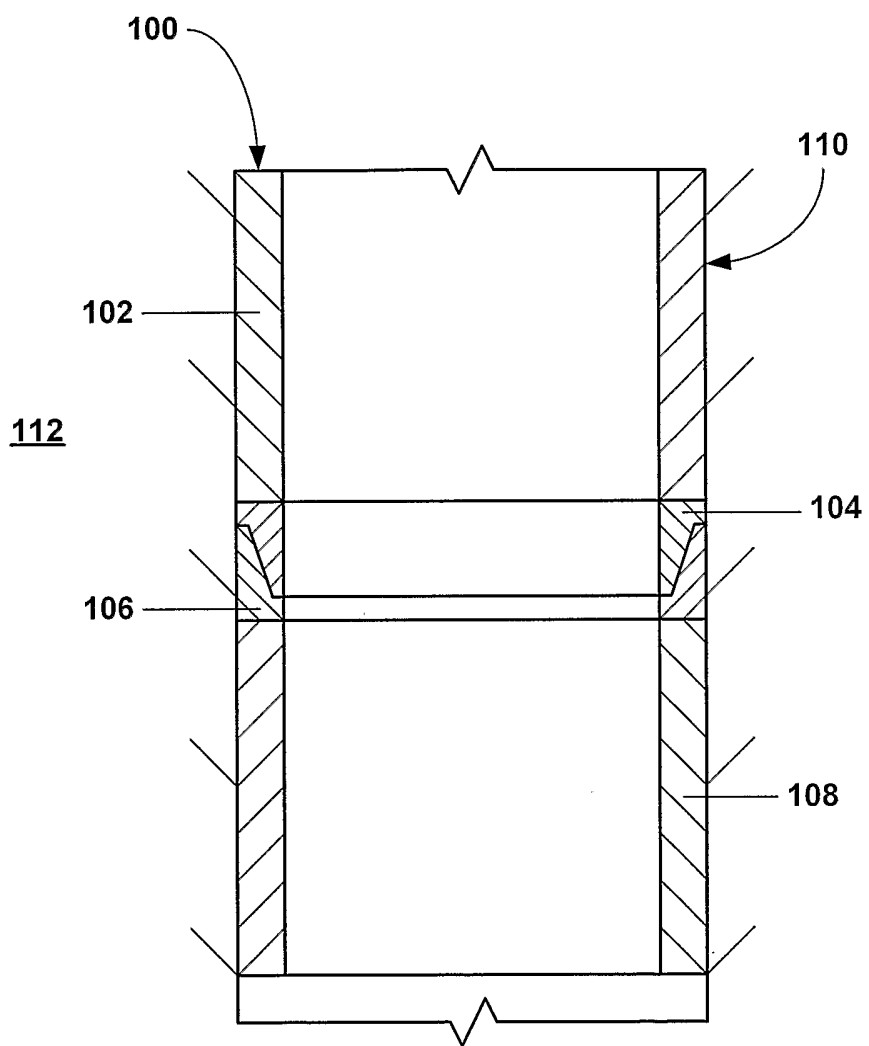

FIG. 11

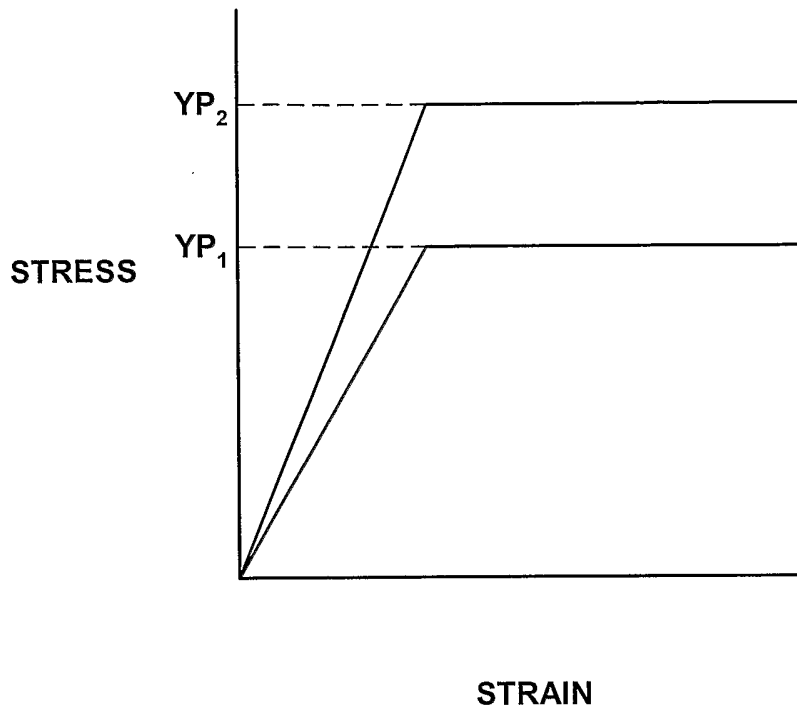

FIG. 12

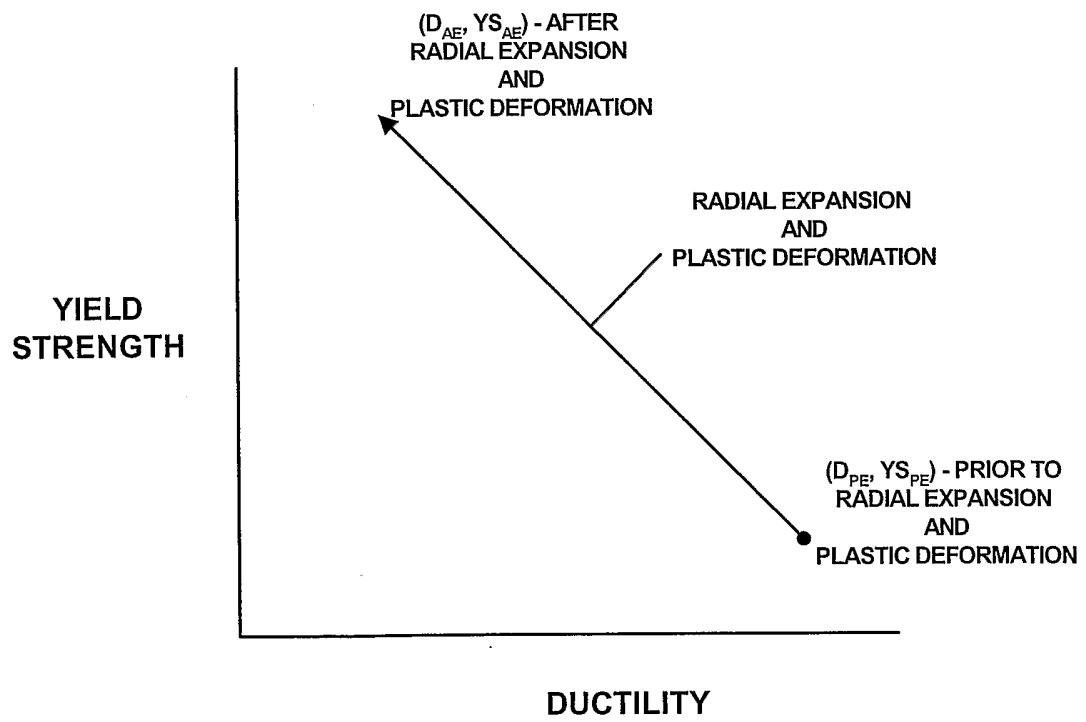

FIG. 13

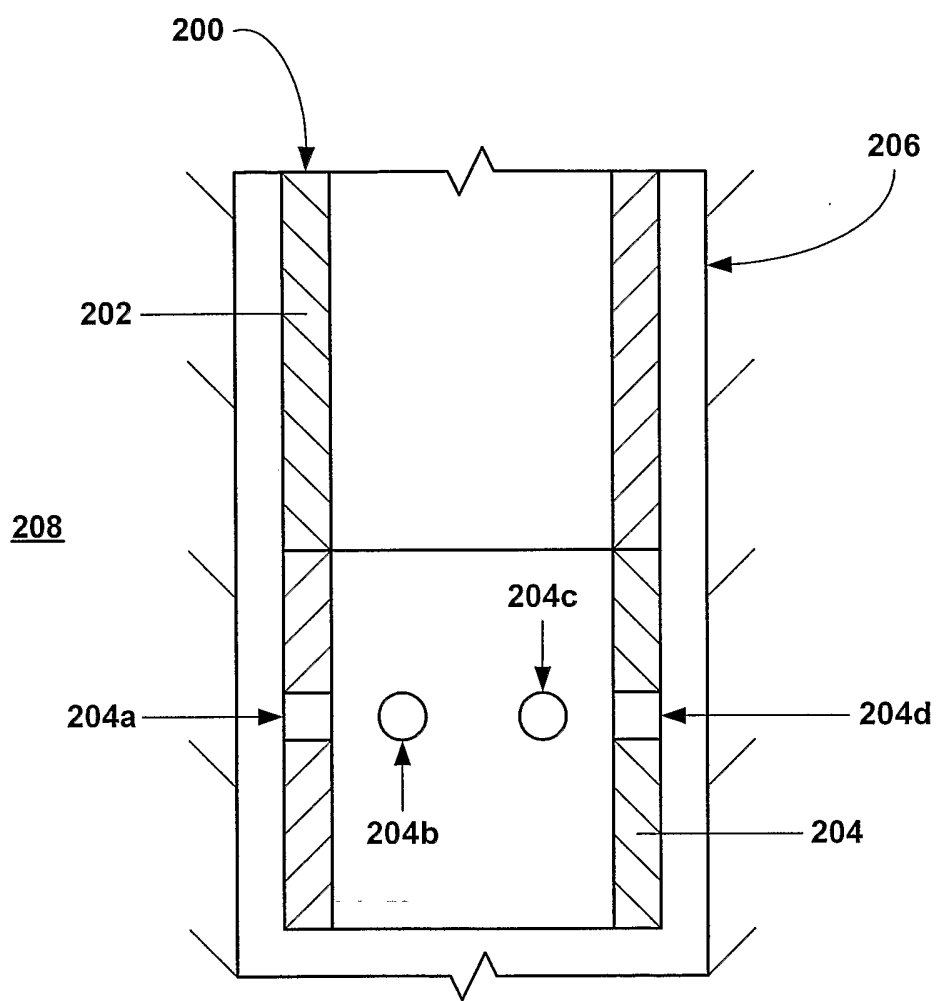

FIG. 14

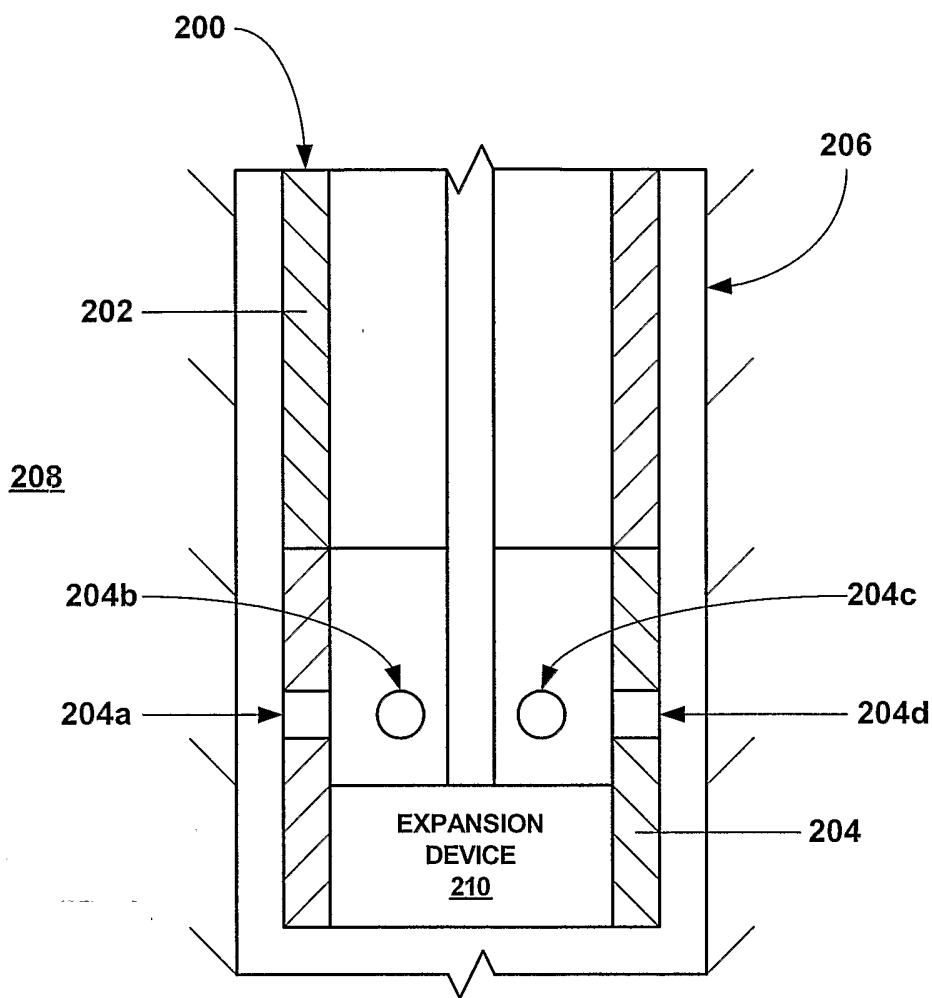

FIG. 15

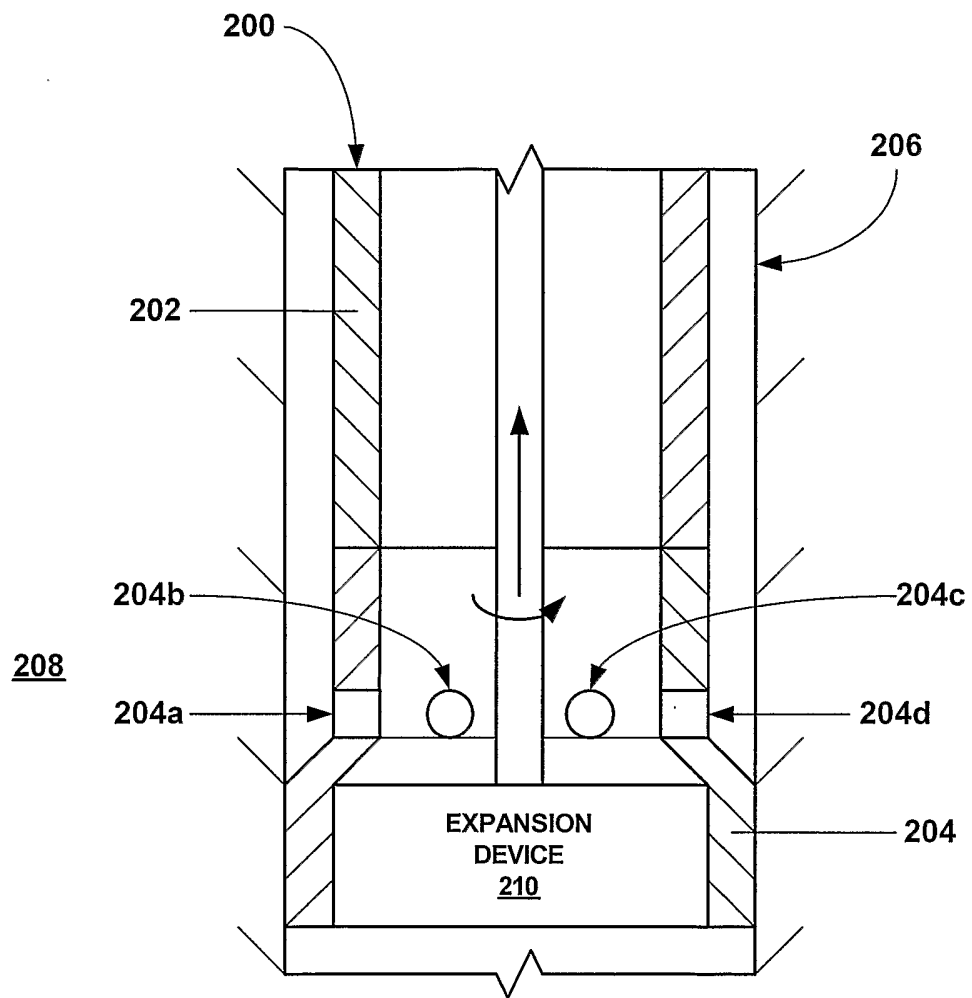

FIG. 16

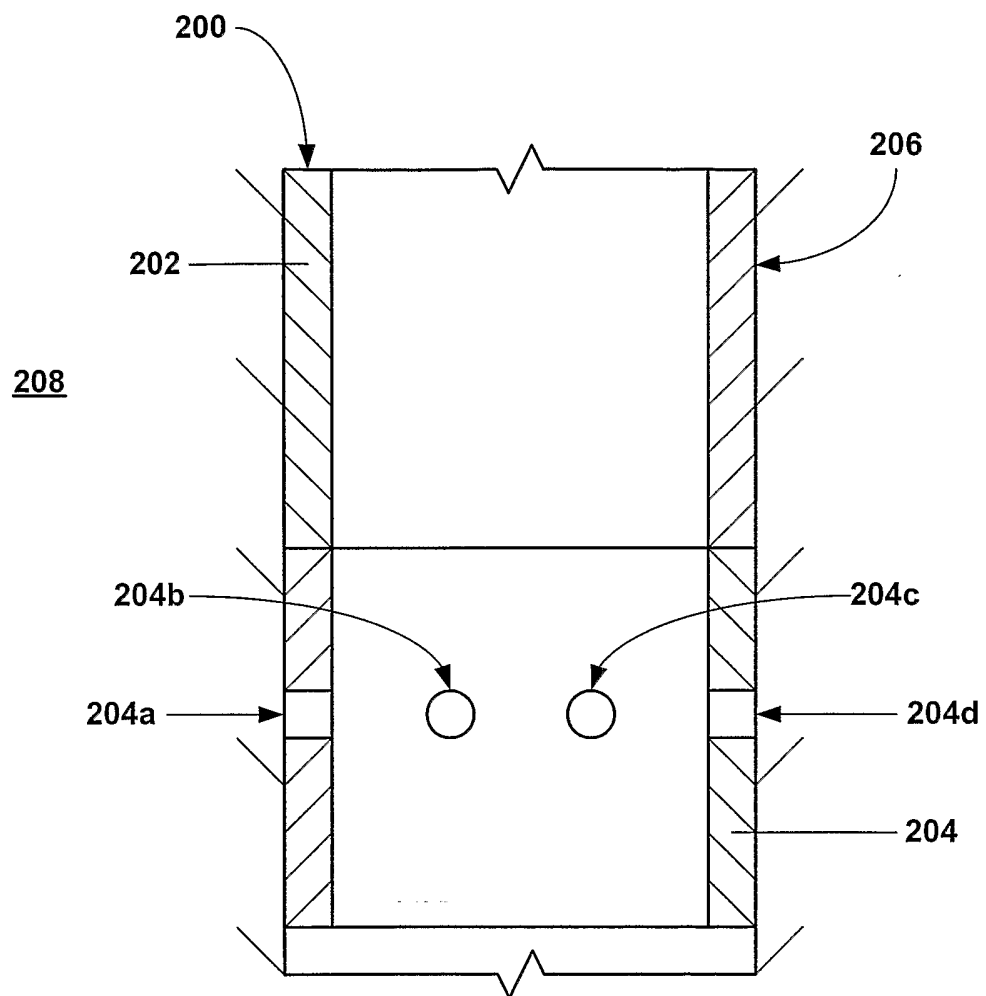

FIG. 17

300
↘

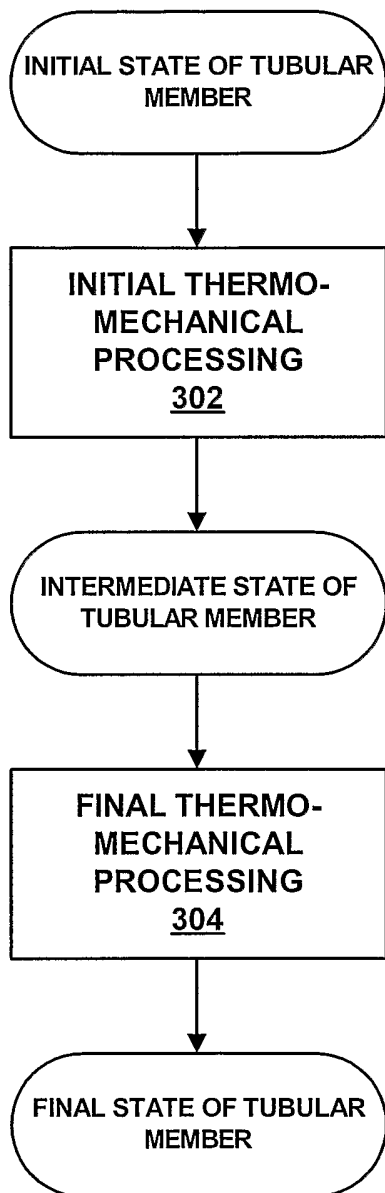

Fig. 18

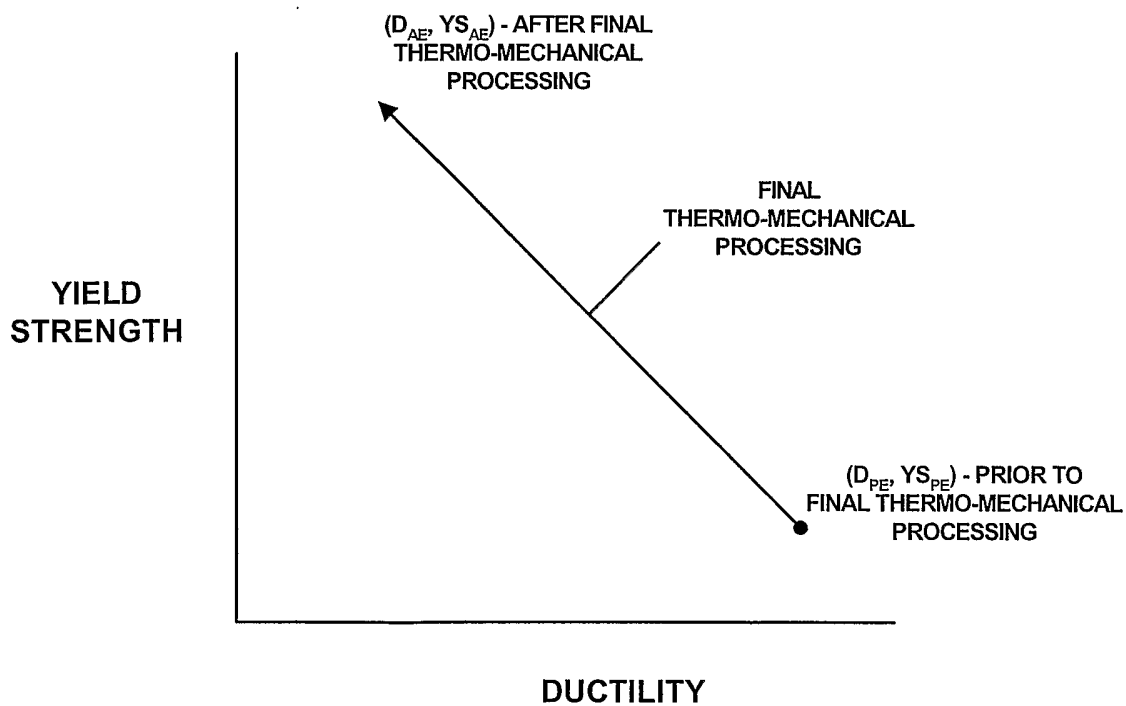

FIG. 19

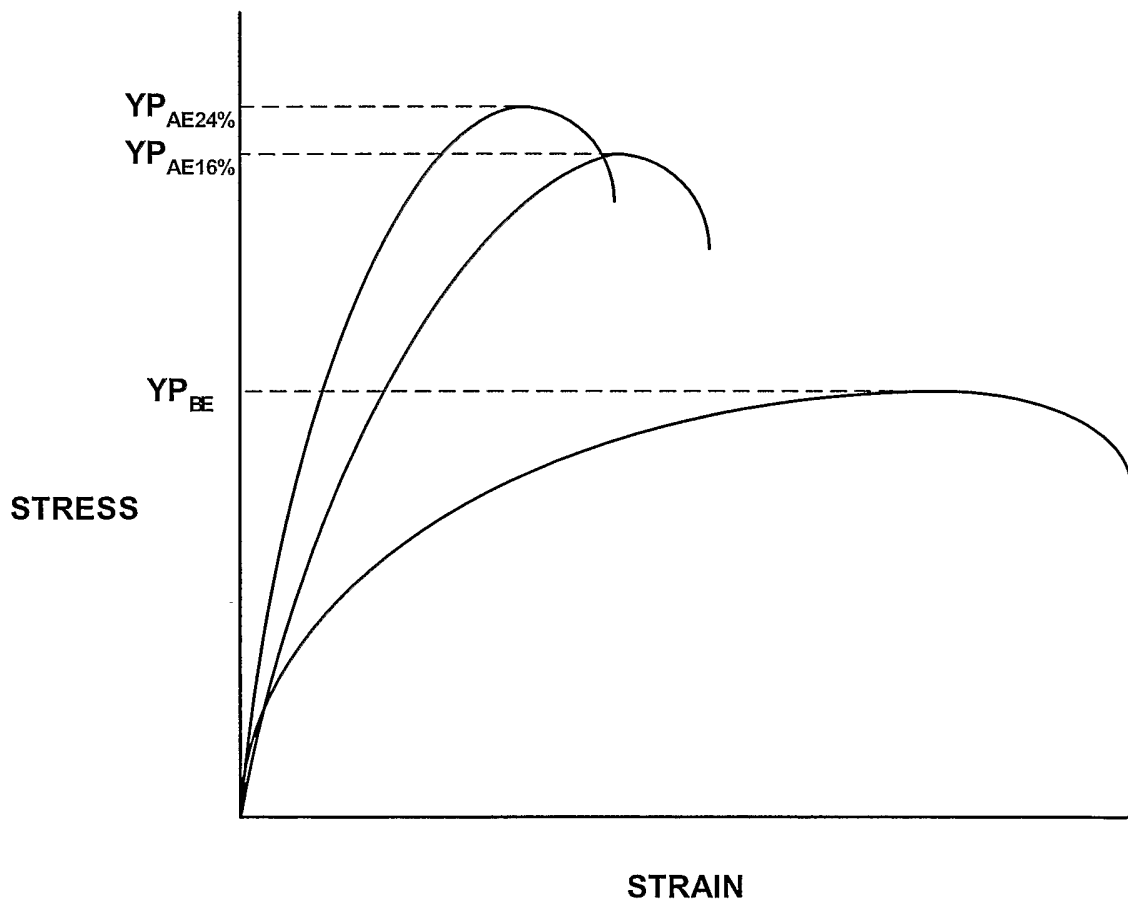

FIG. 20

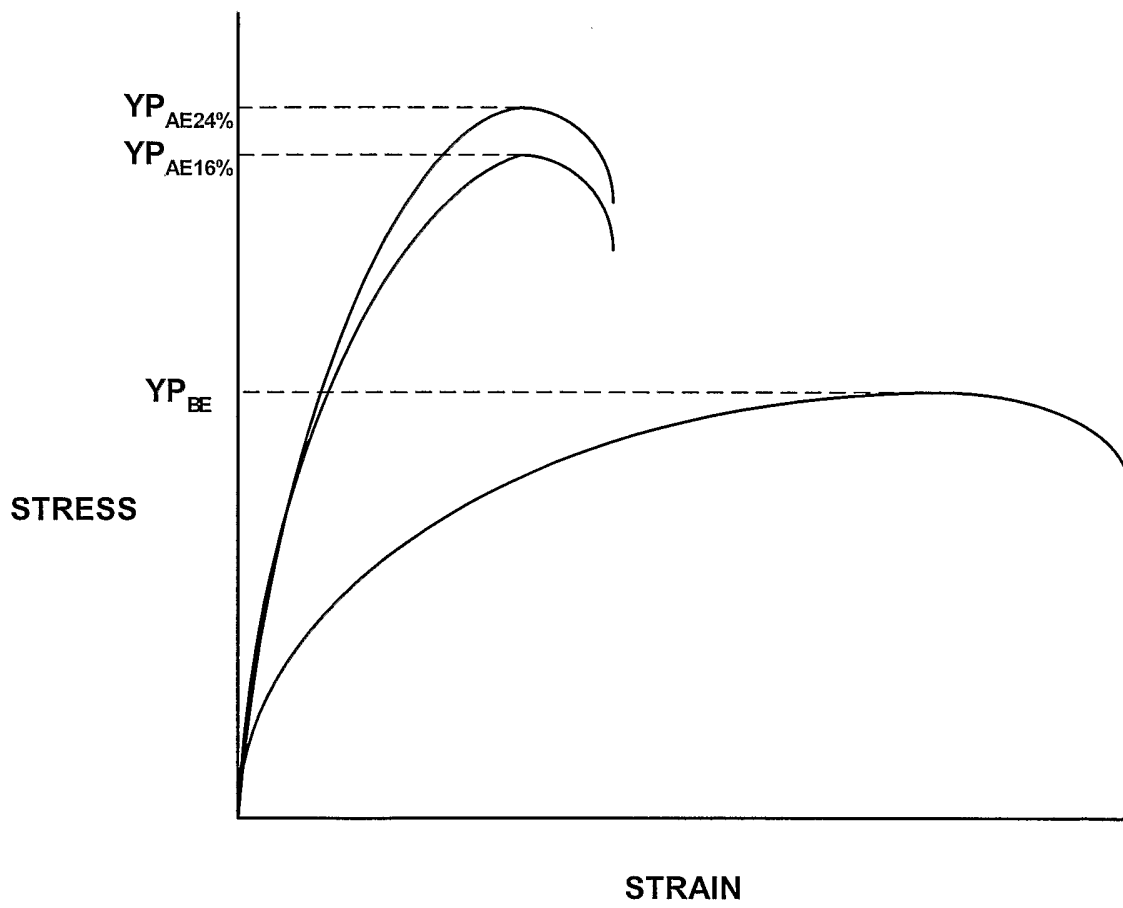

FIG. 21

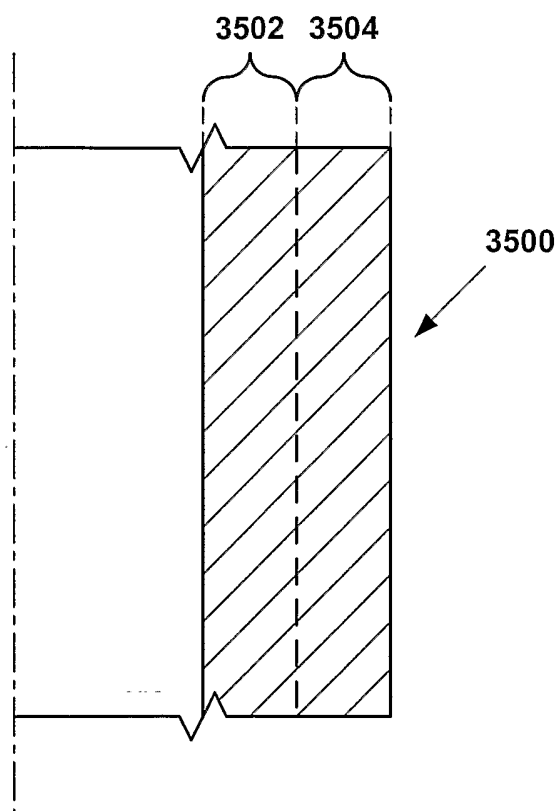

FIG. 35a

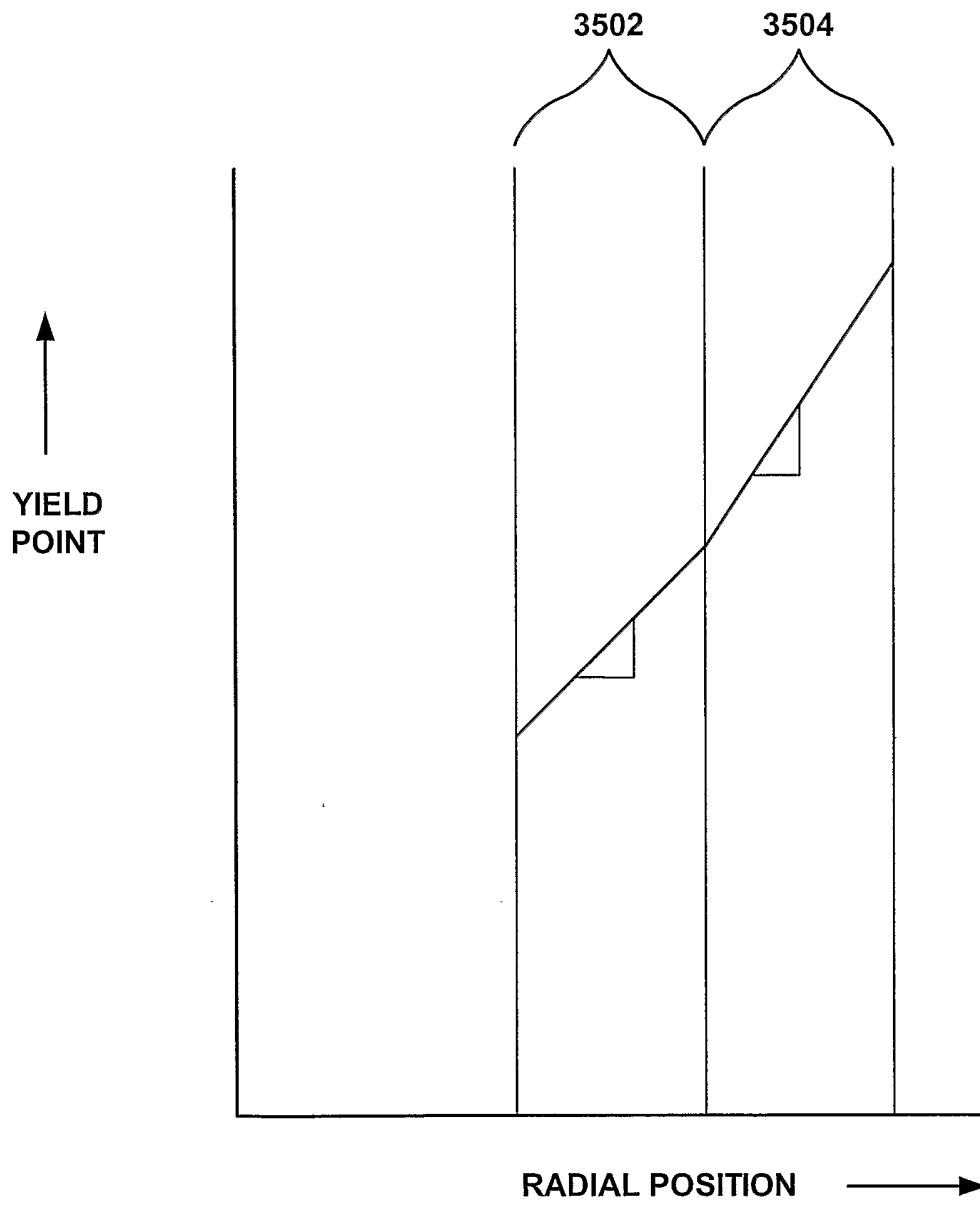

FIG. 35b

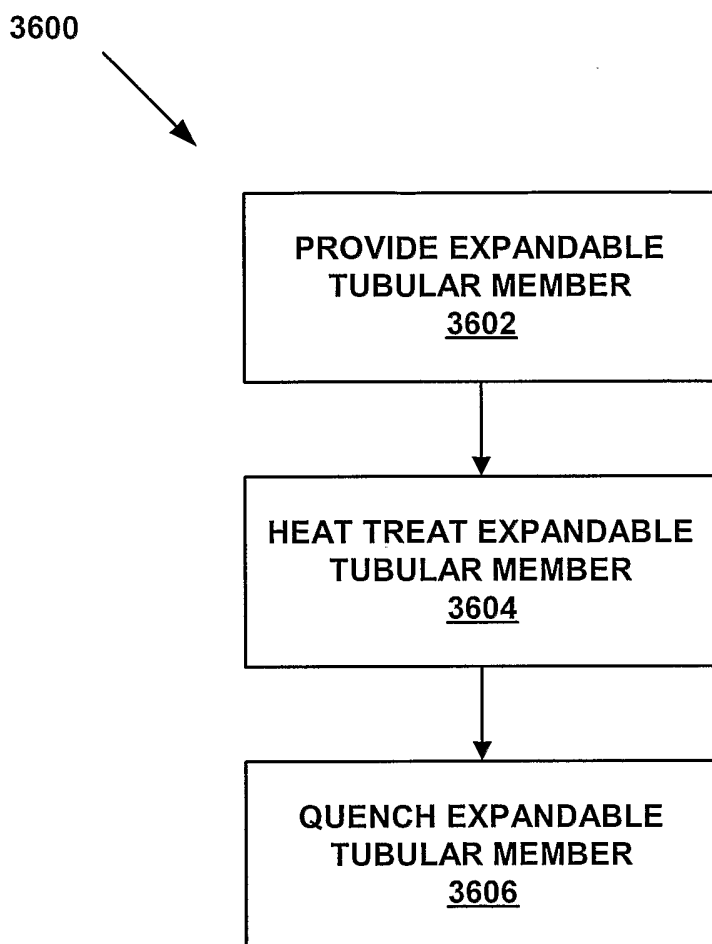

FIG. 36a

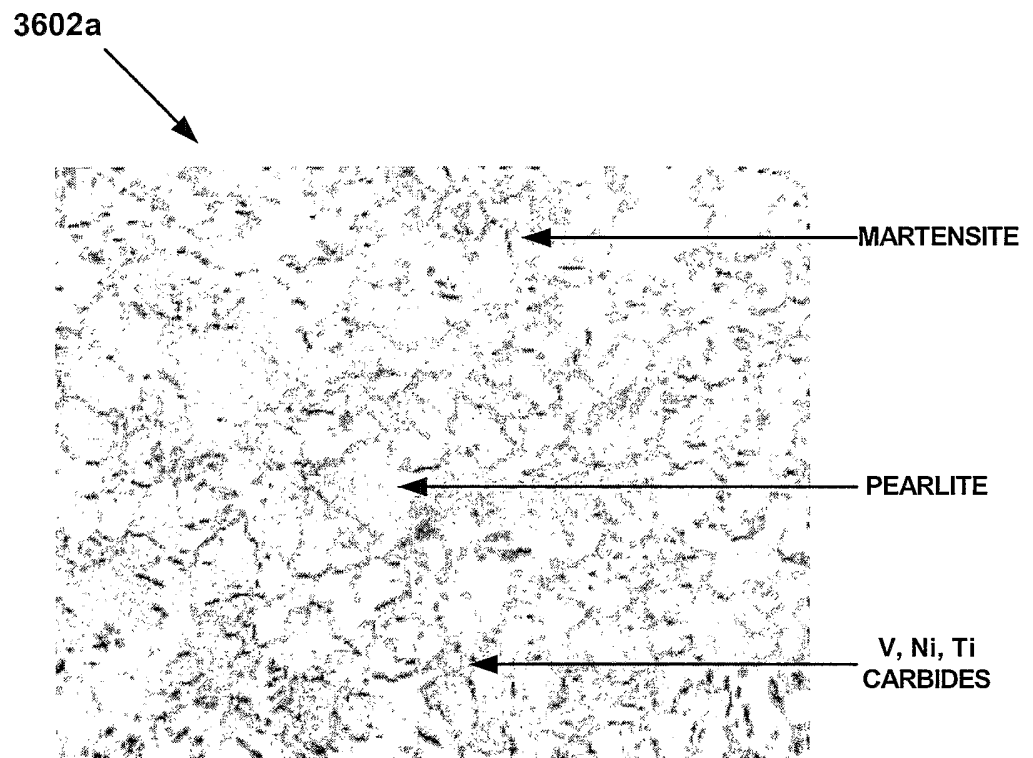

Fig. 36b

3602a

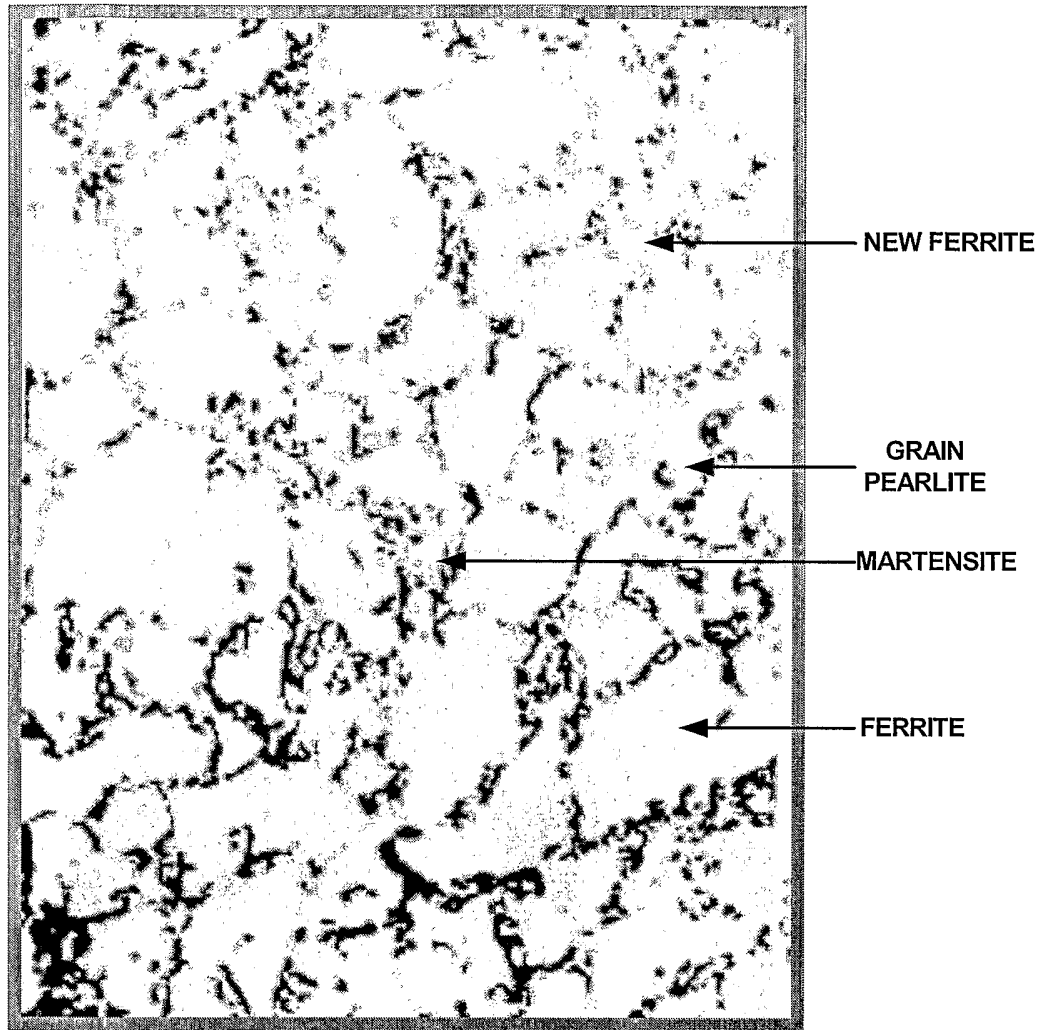

Fig. 36c

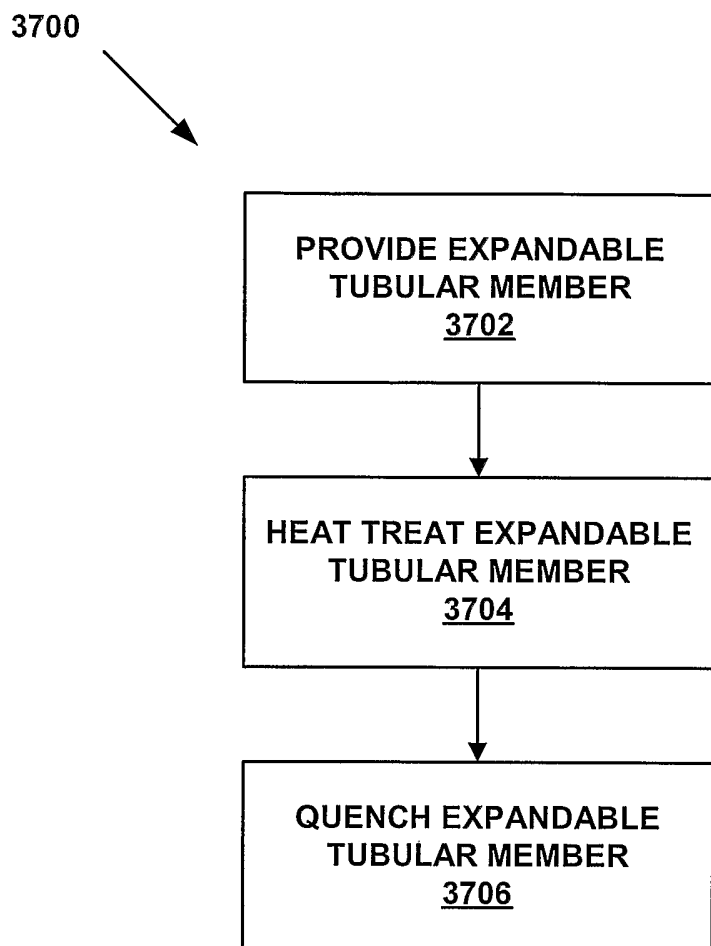

FIG. 37a

3702a

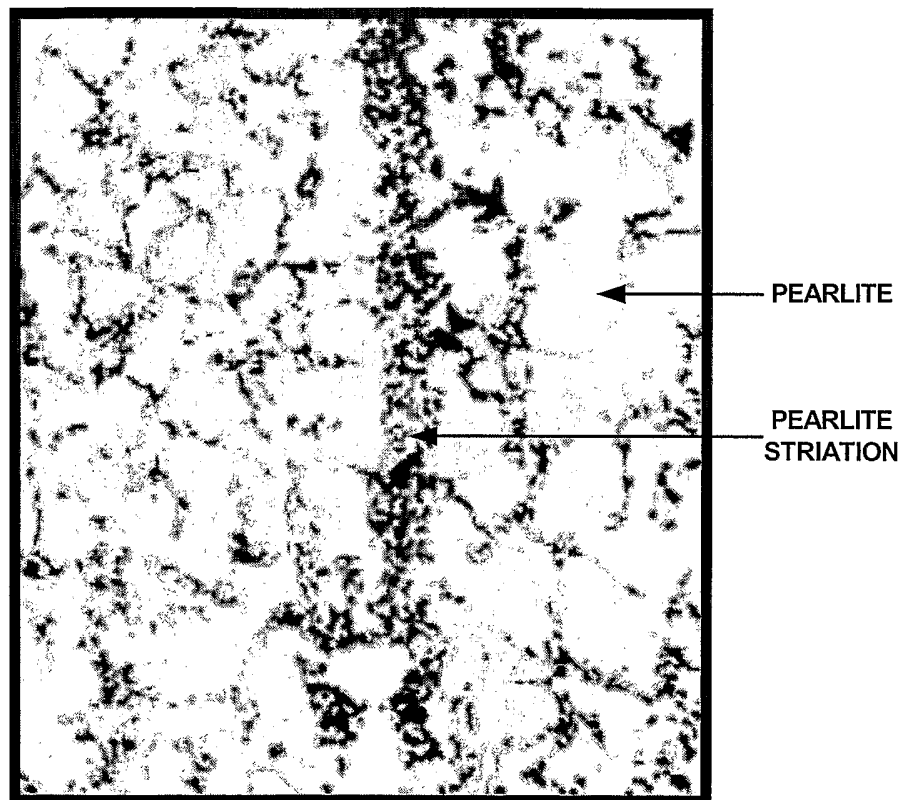

Fig. 37b

3702a

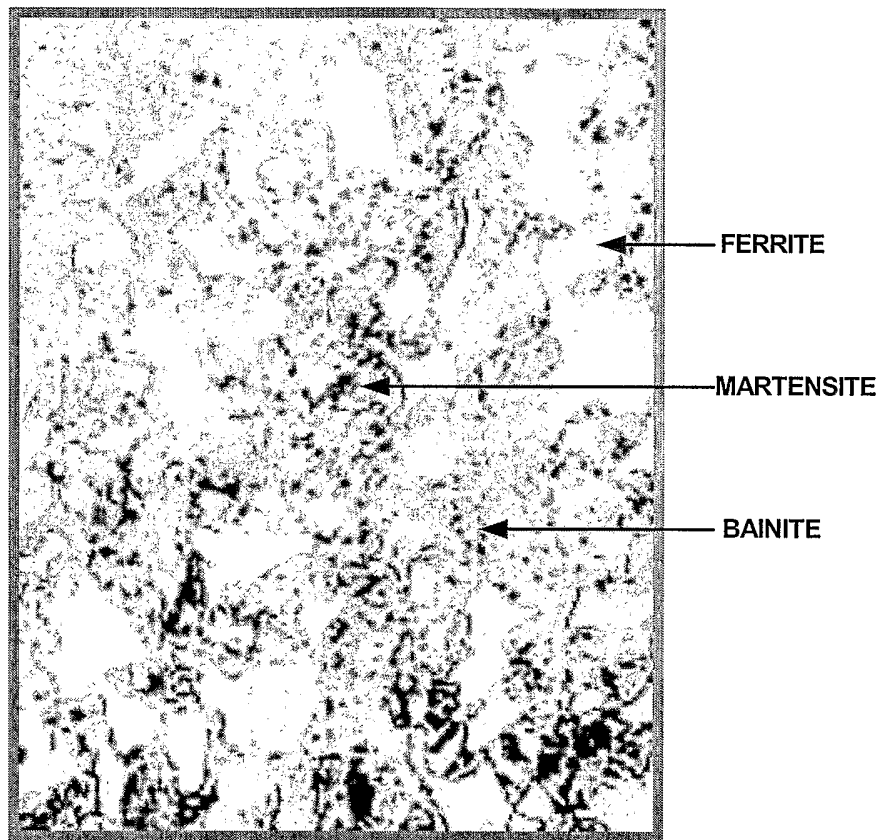

Fig. 37c

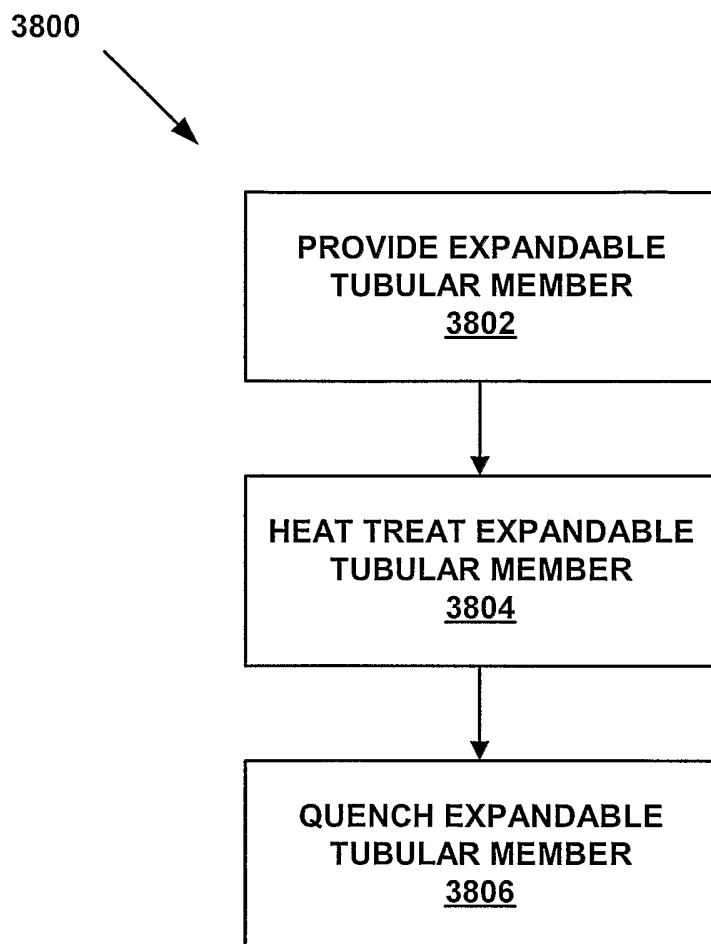

FIG. 38a

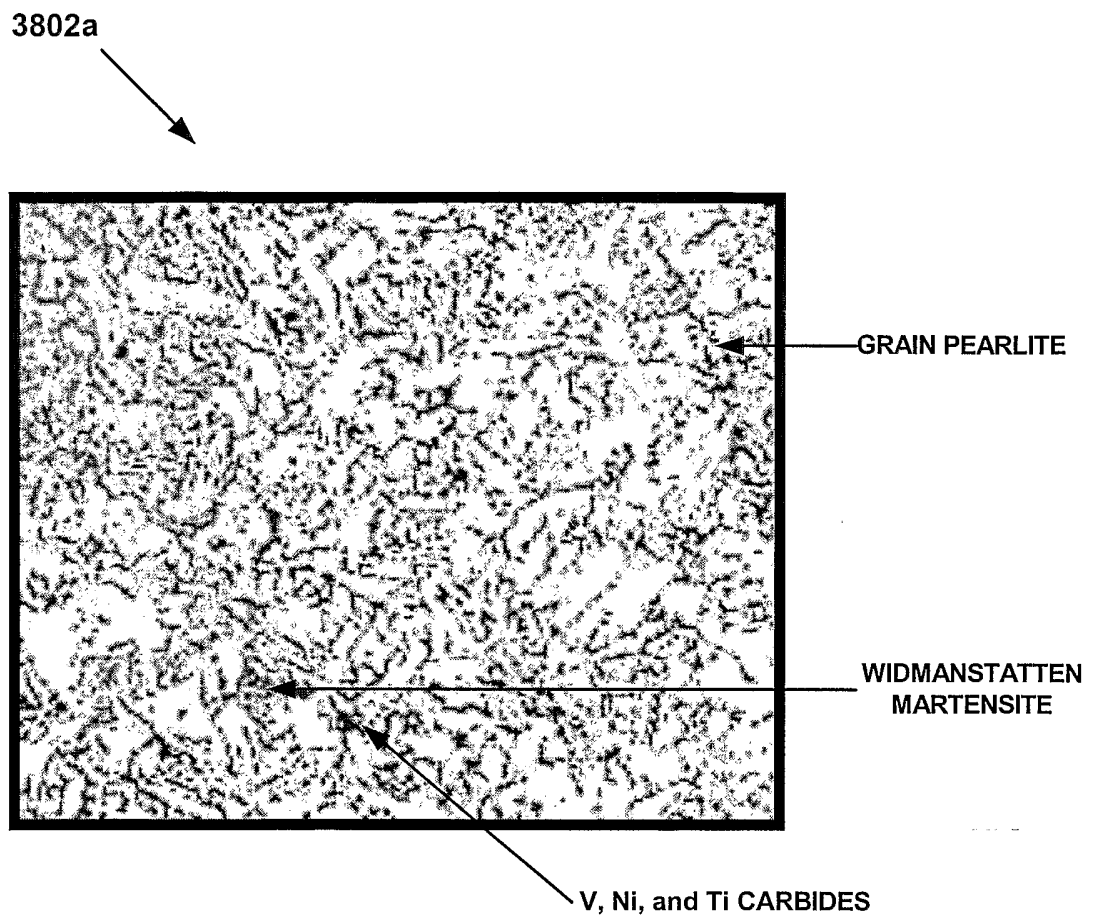

Fig. 38b

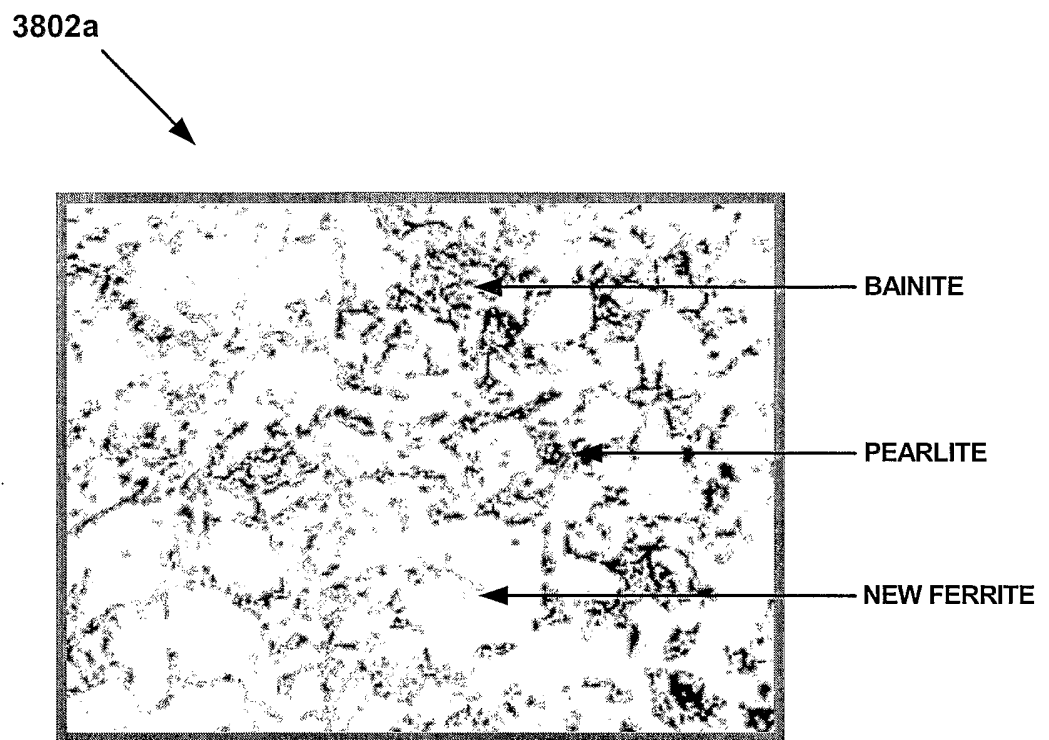

Fig. 38c

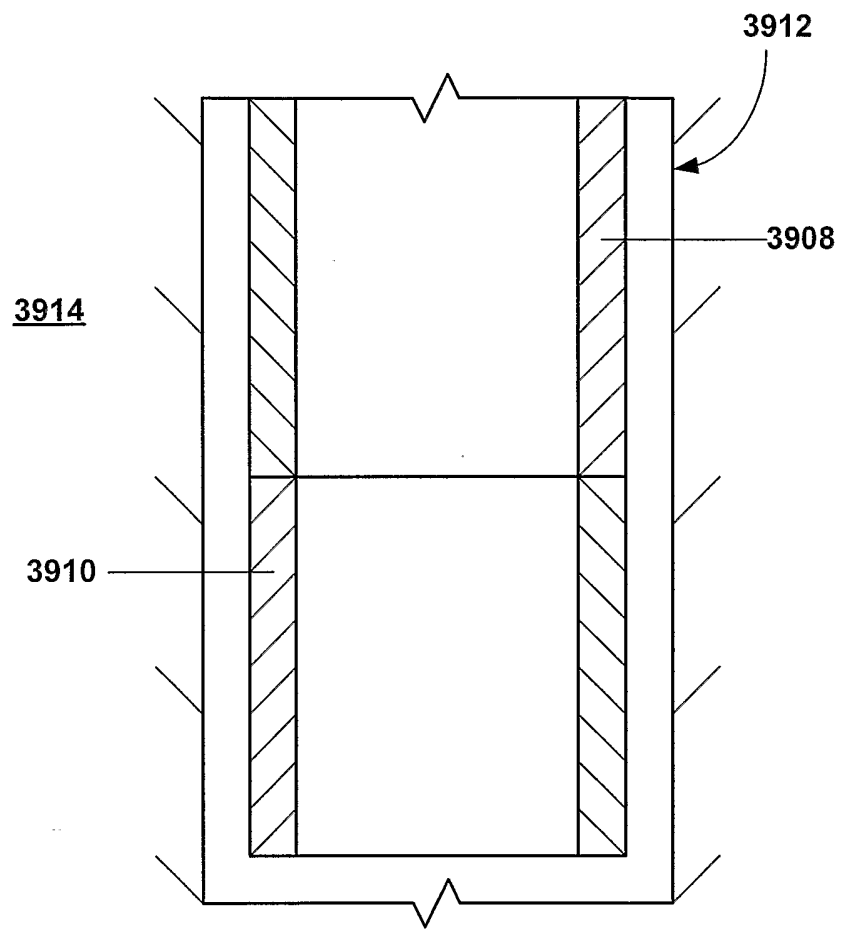

FIG. 39a

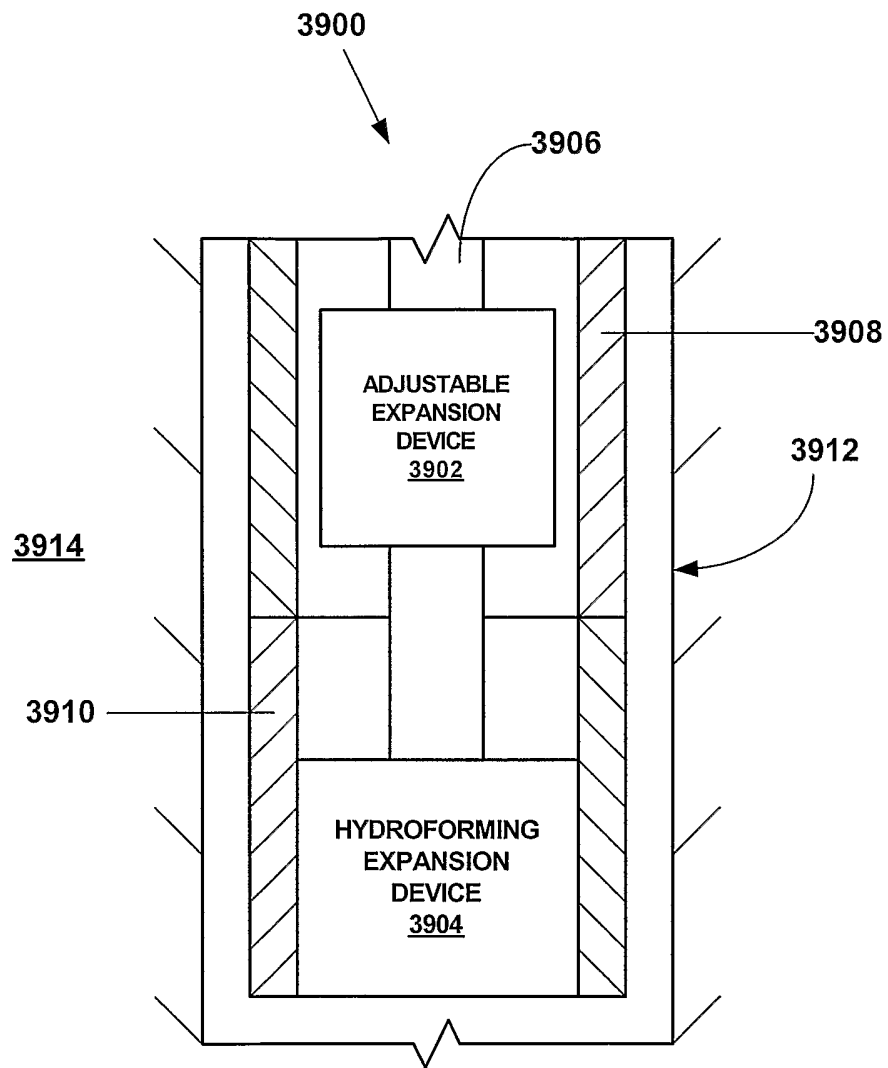

FIG. 39b

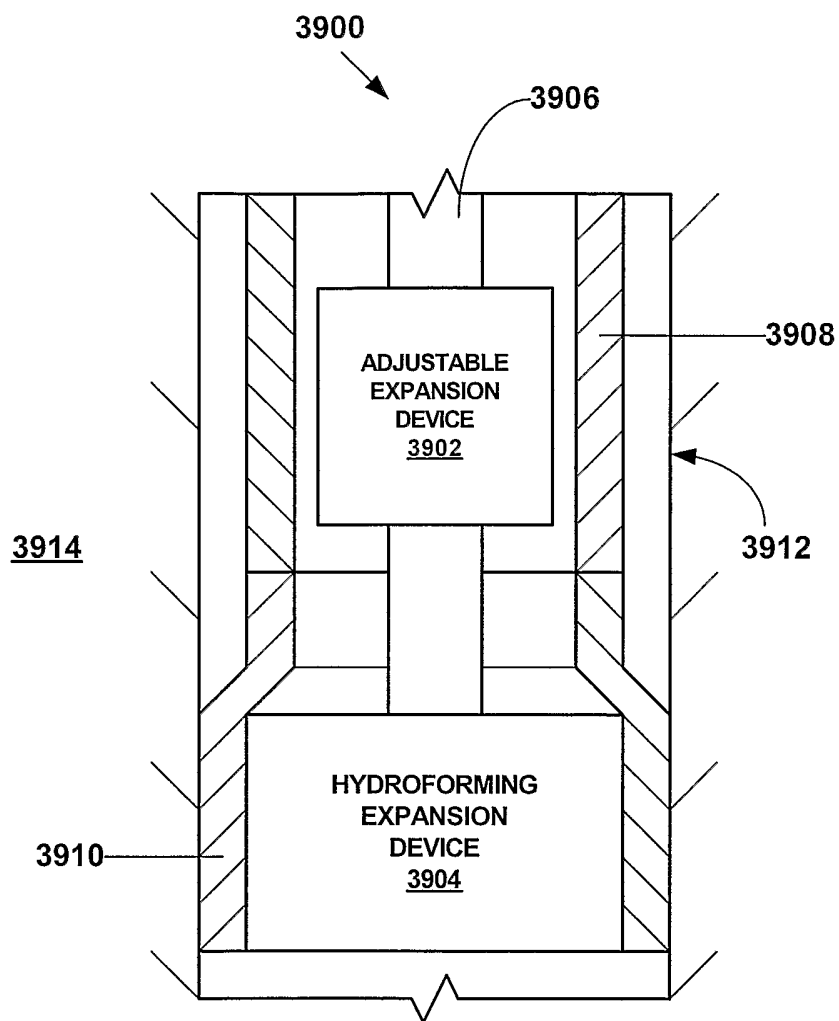

FIG. 39c

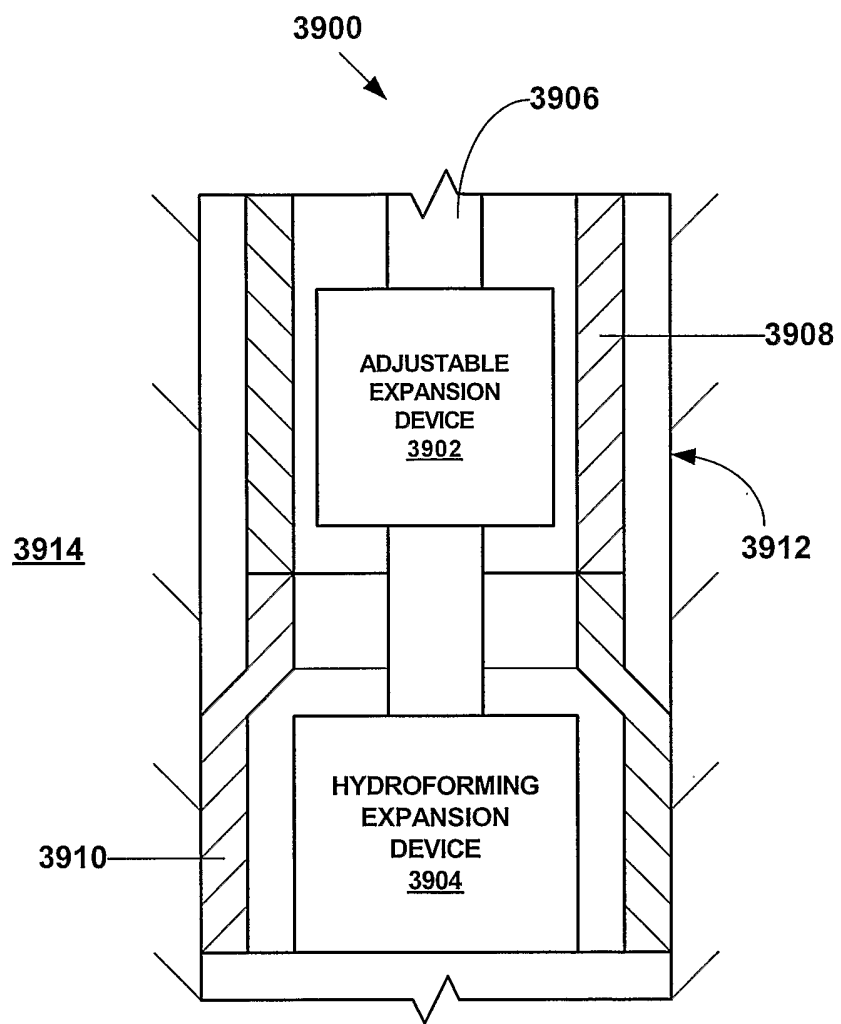

FIG. 39d

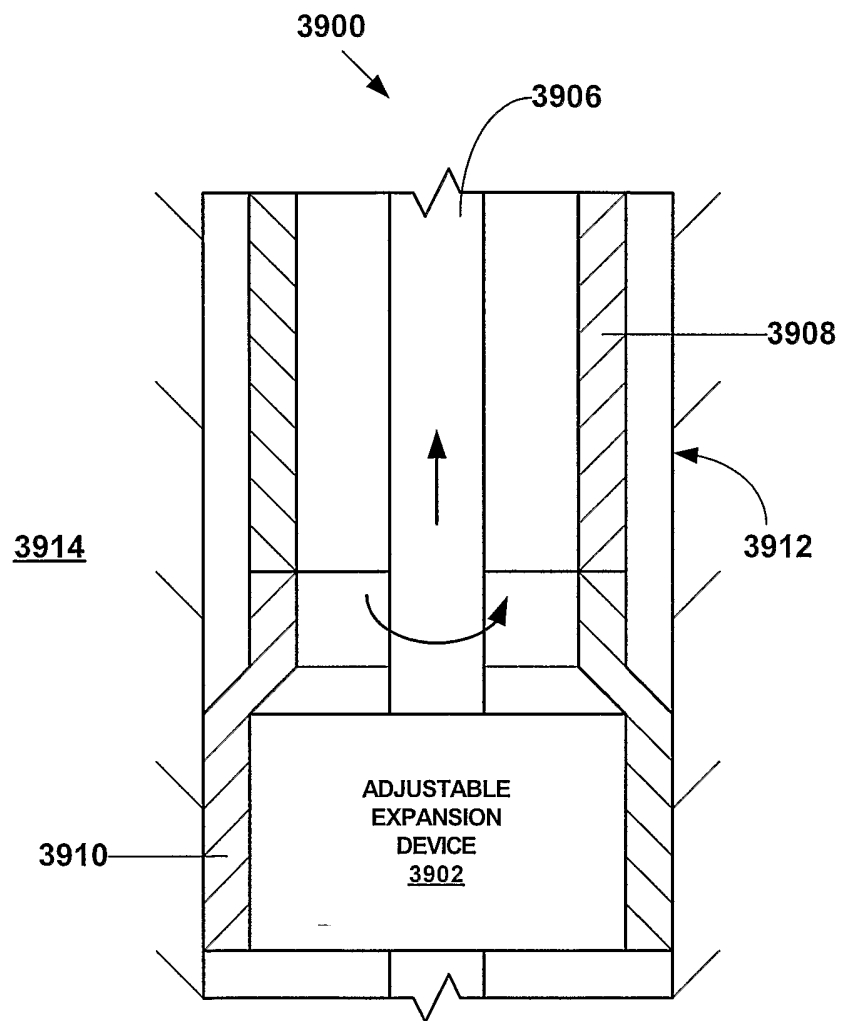

FIG. 39e

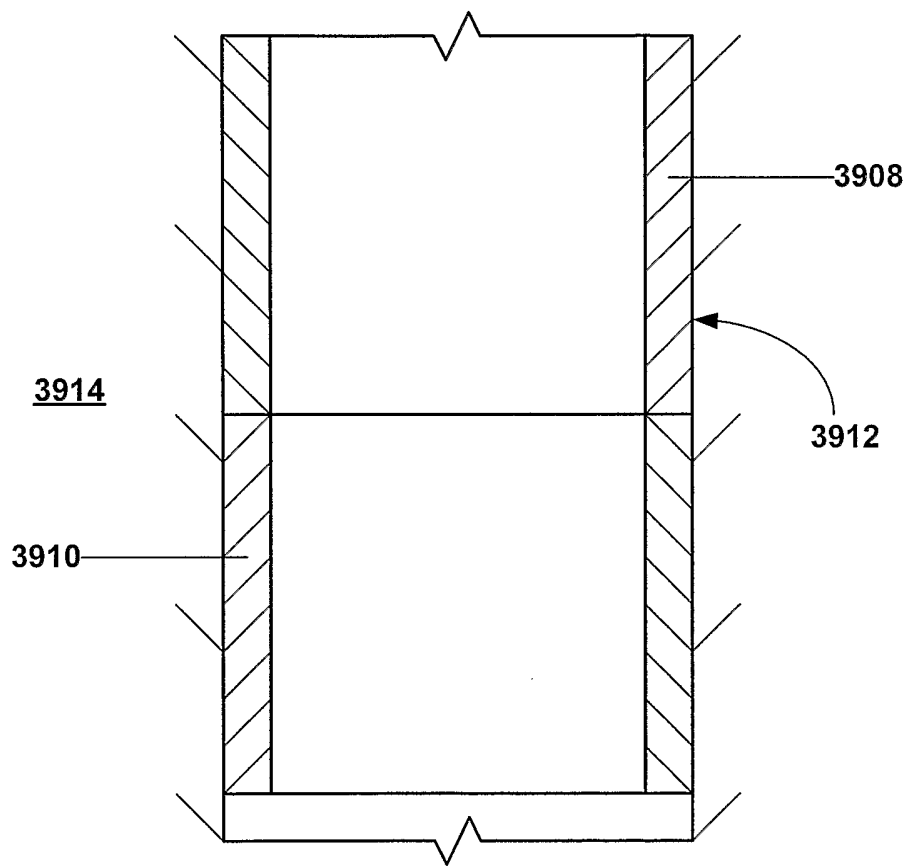

FIG. 39f

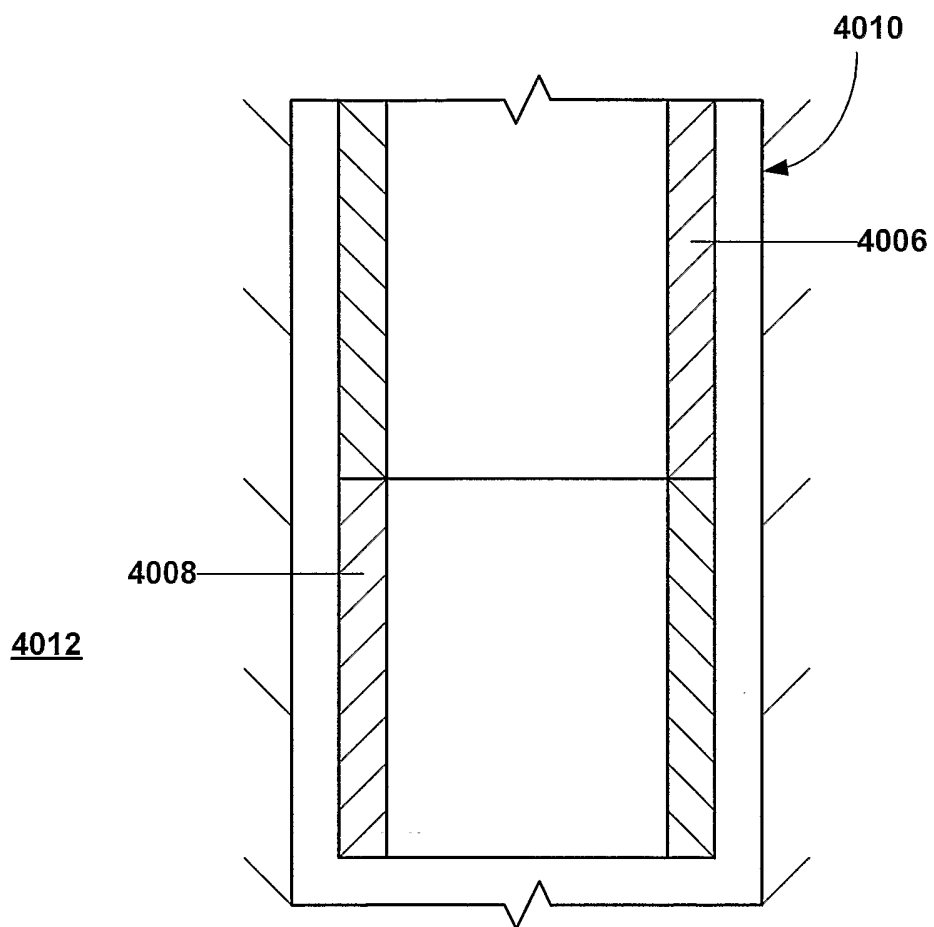

FIG. 40a

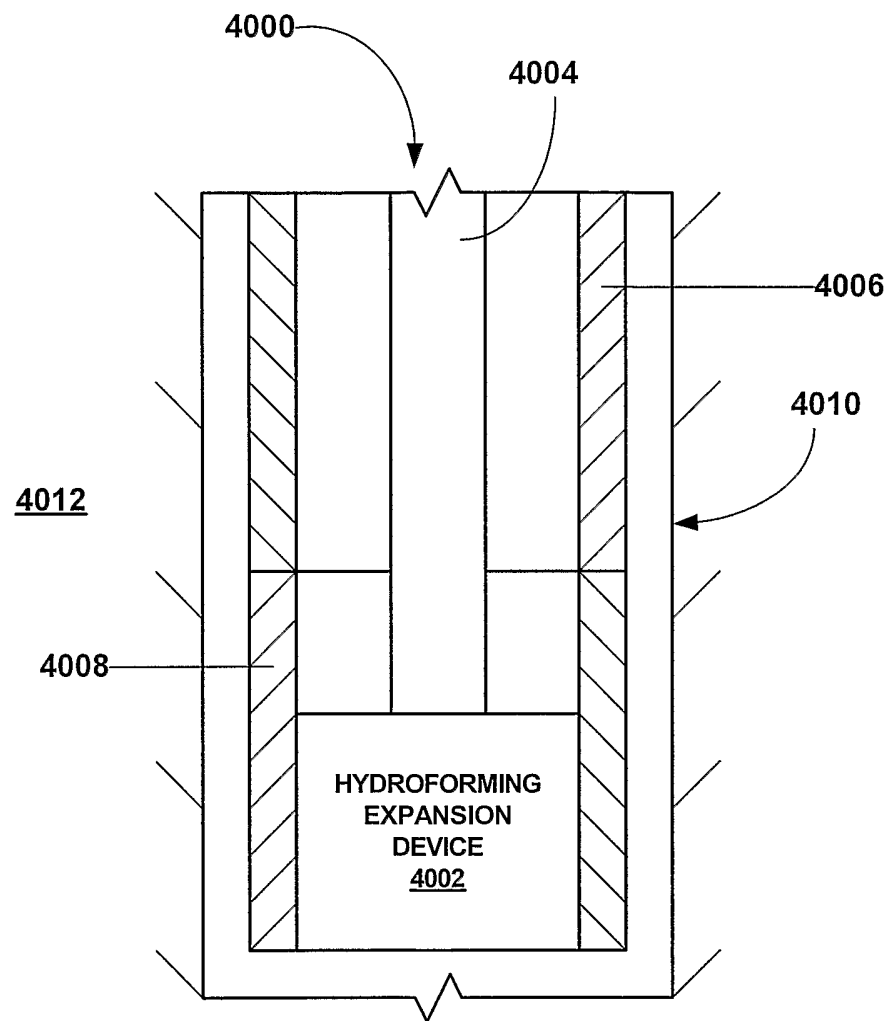

FIG. 40b

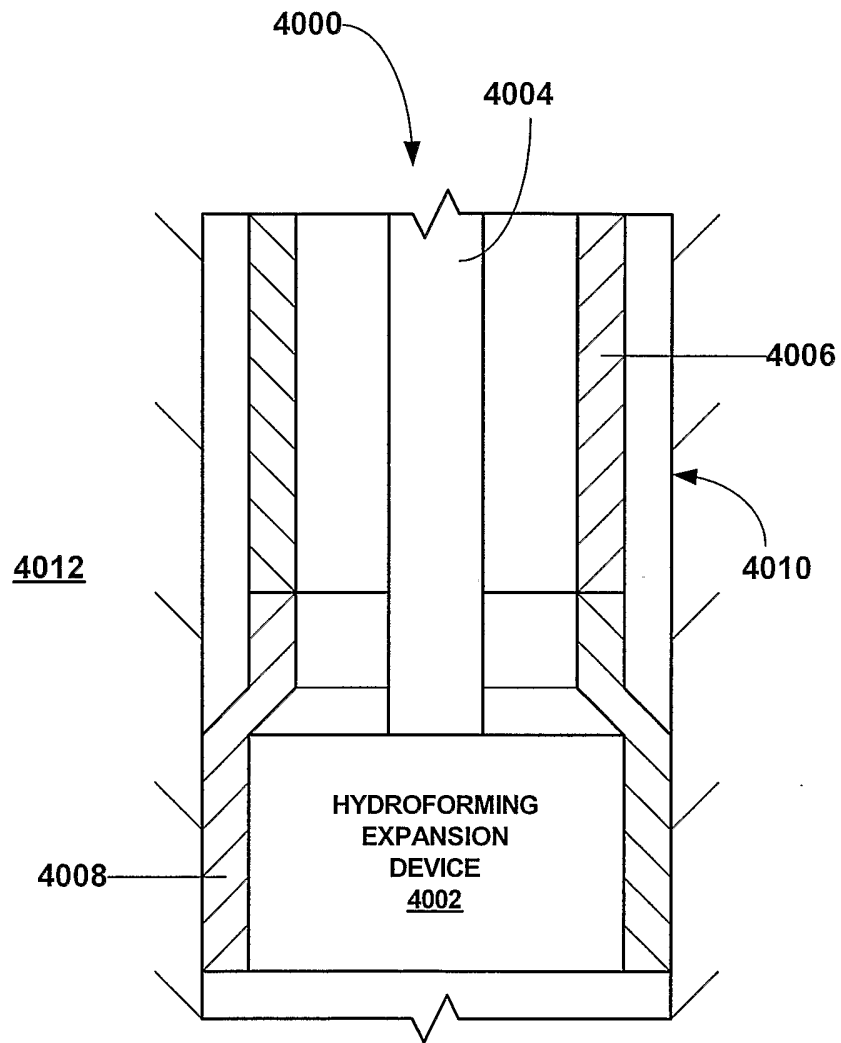

FIG. 40c

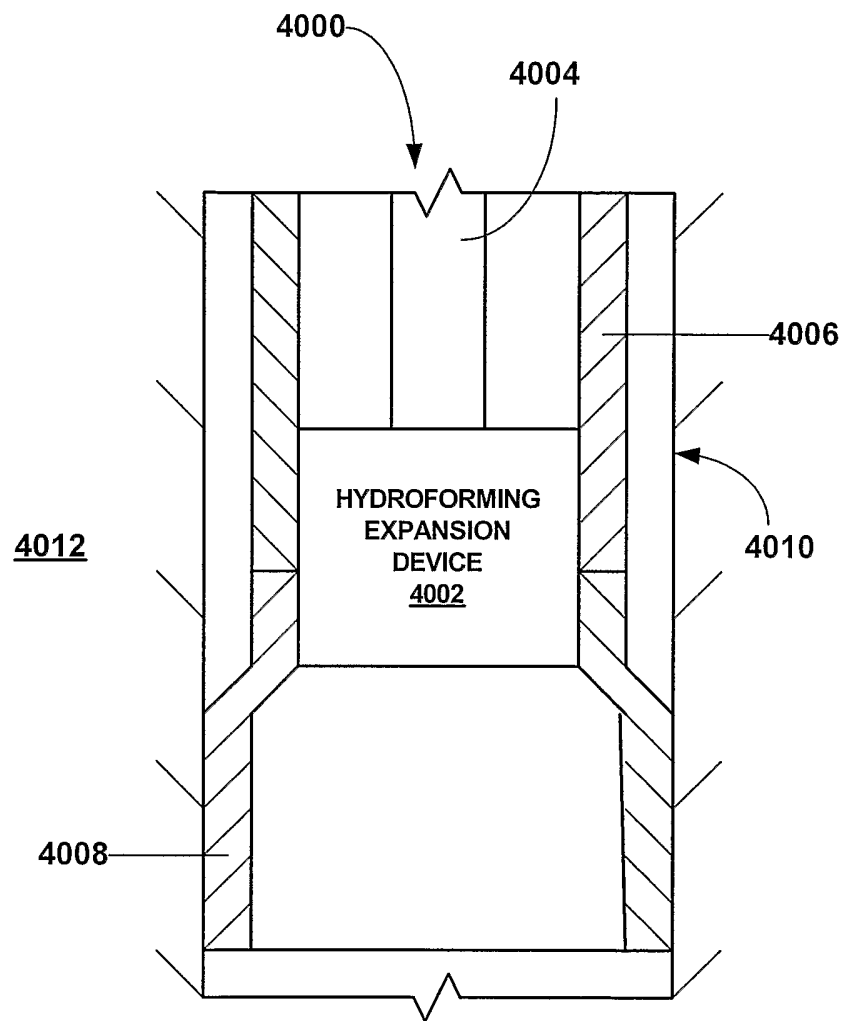

FIG. 40d

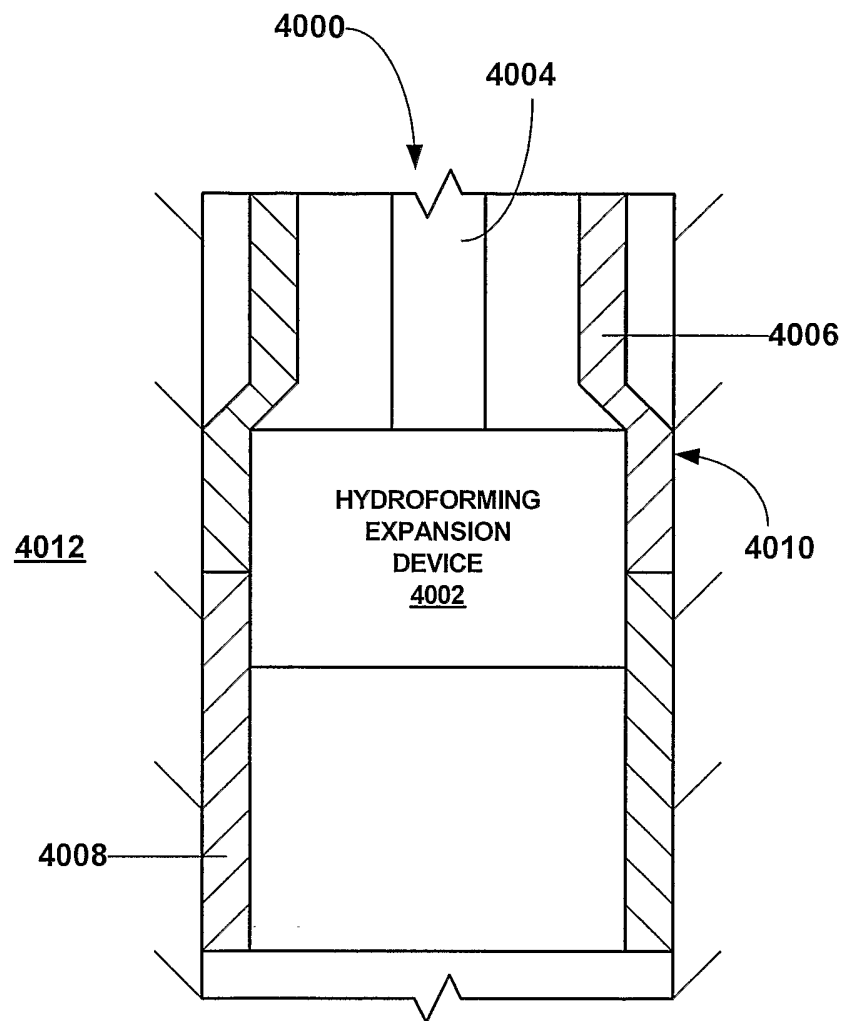

FIG. 40e

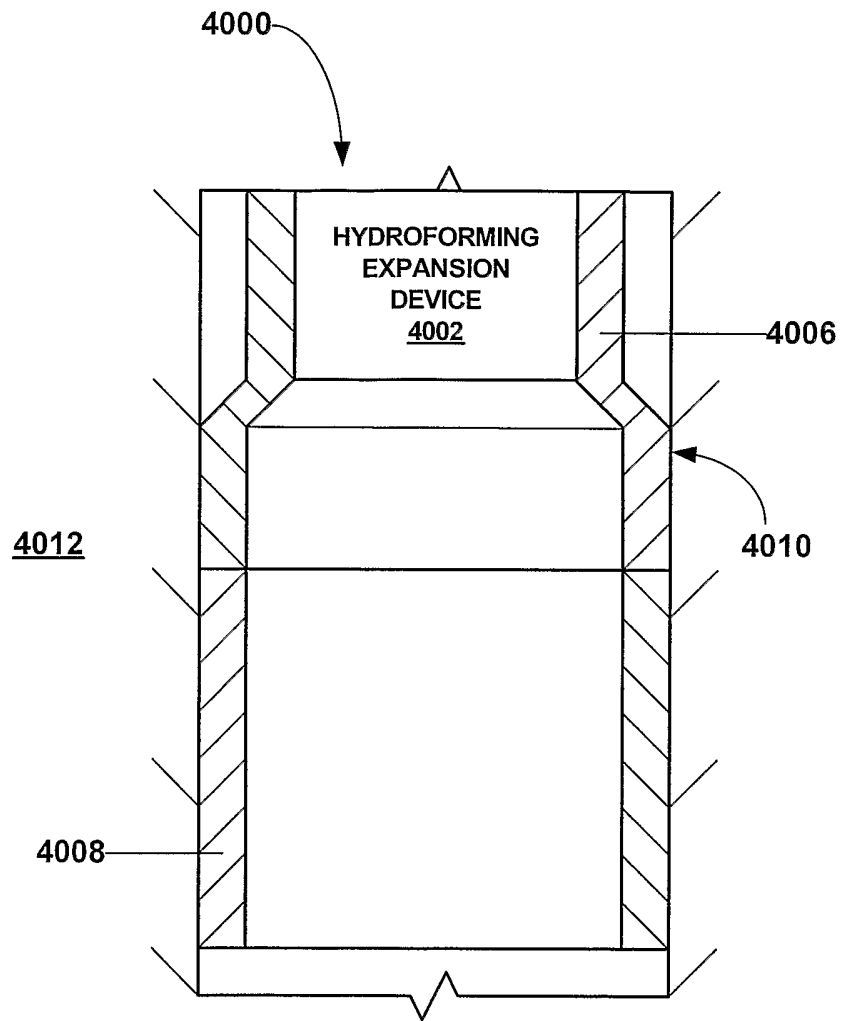

FIG. 40f

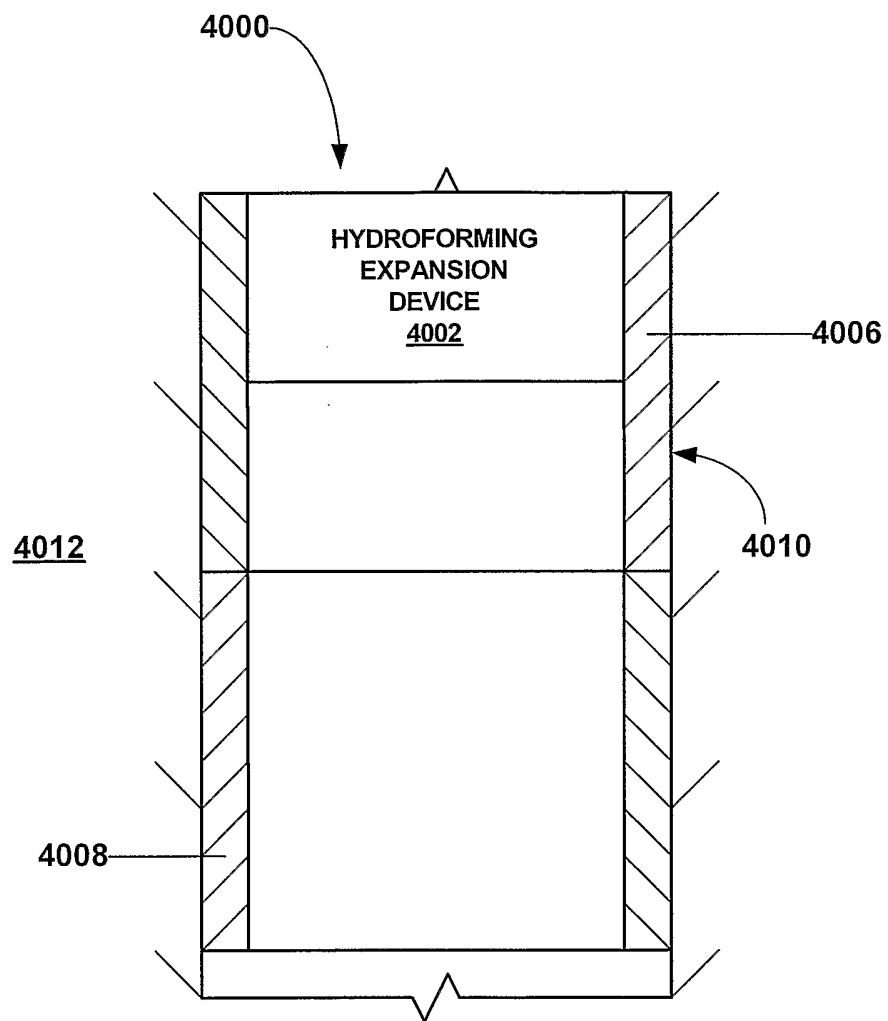

FIG. 40g

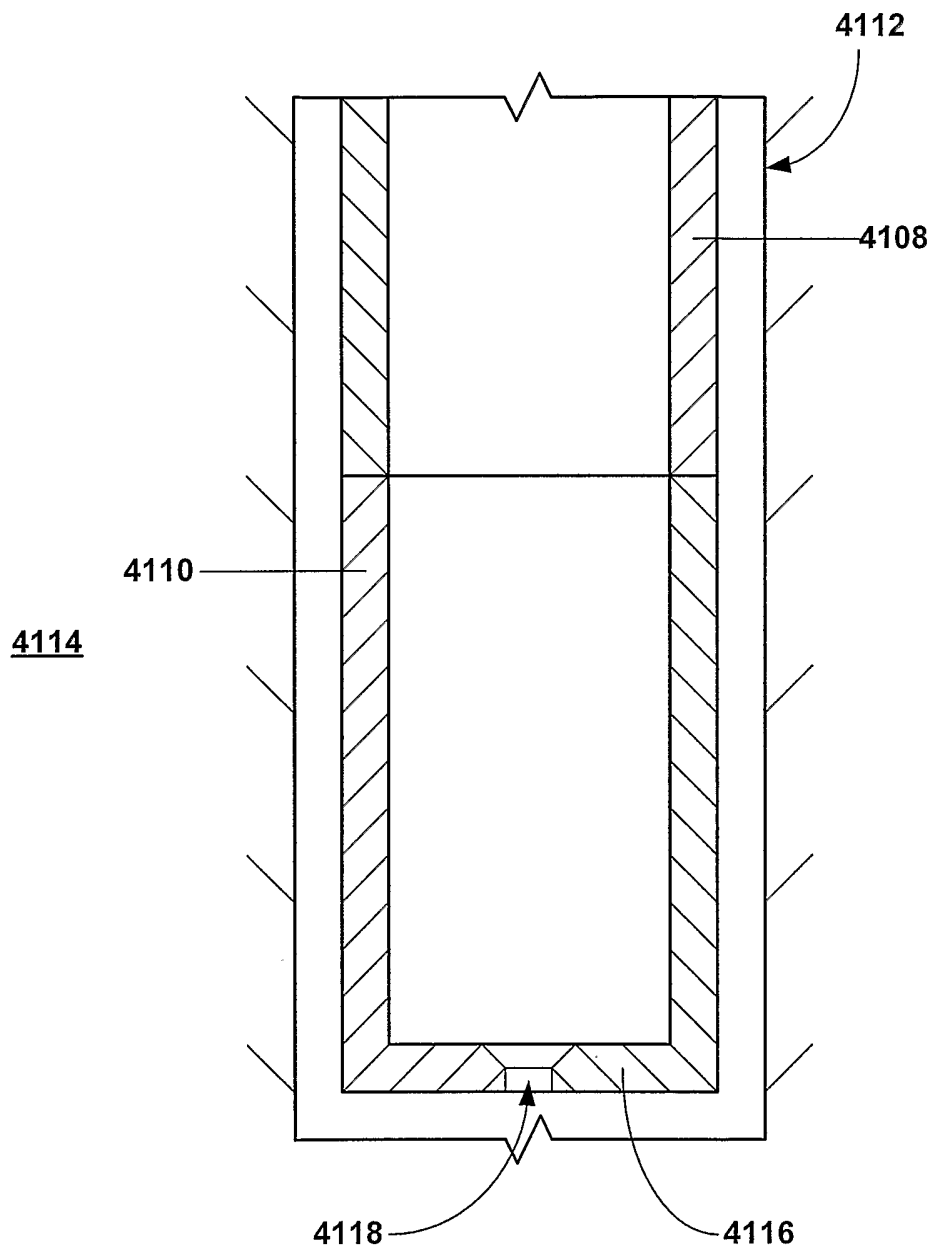

FIG. 41a

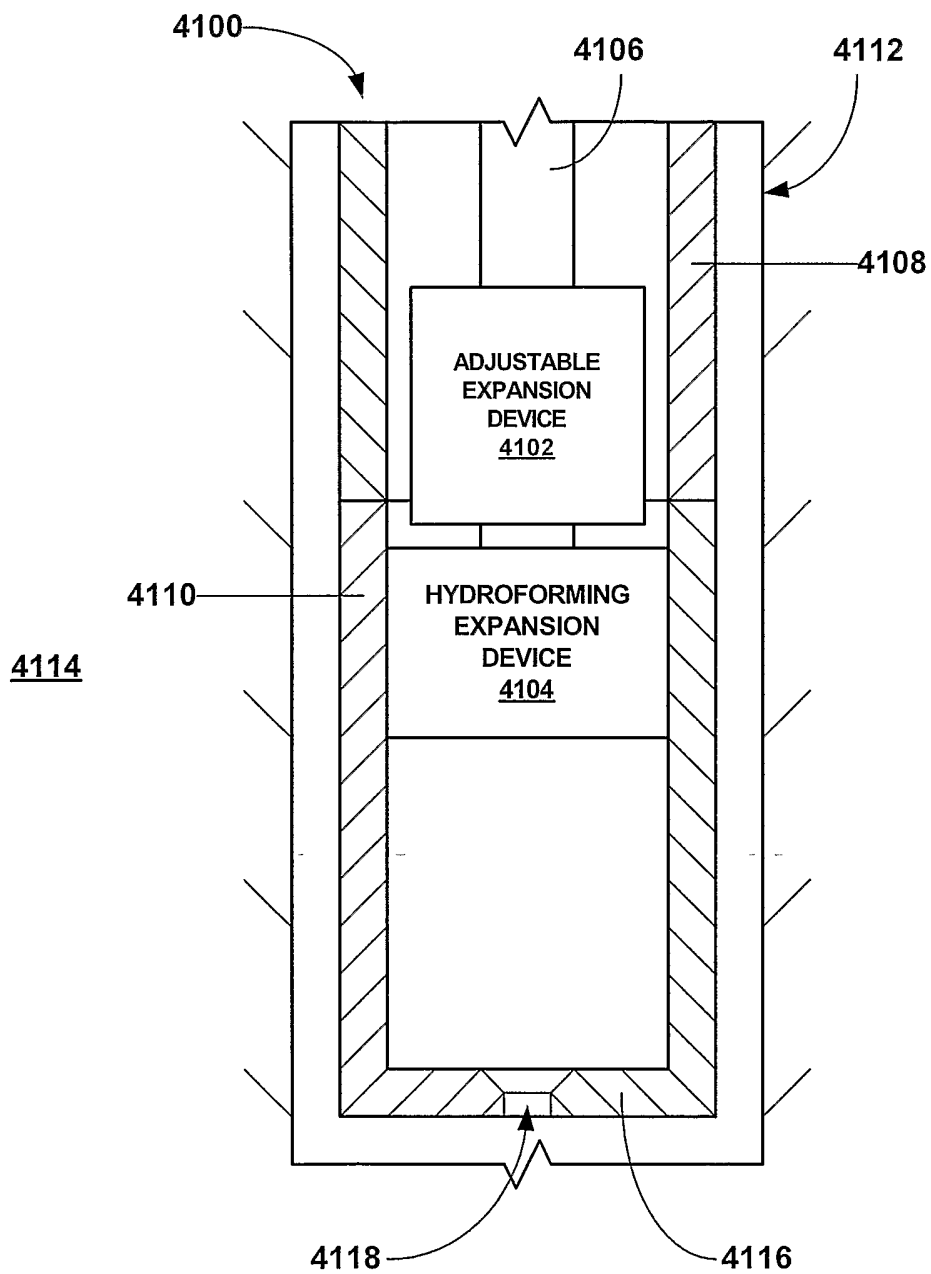

FIG. 41b

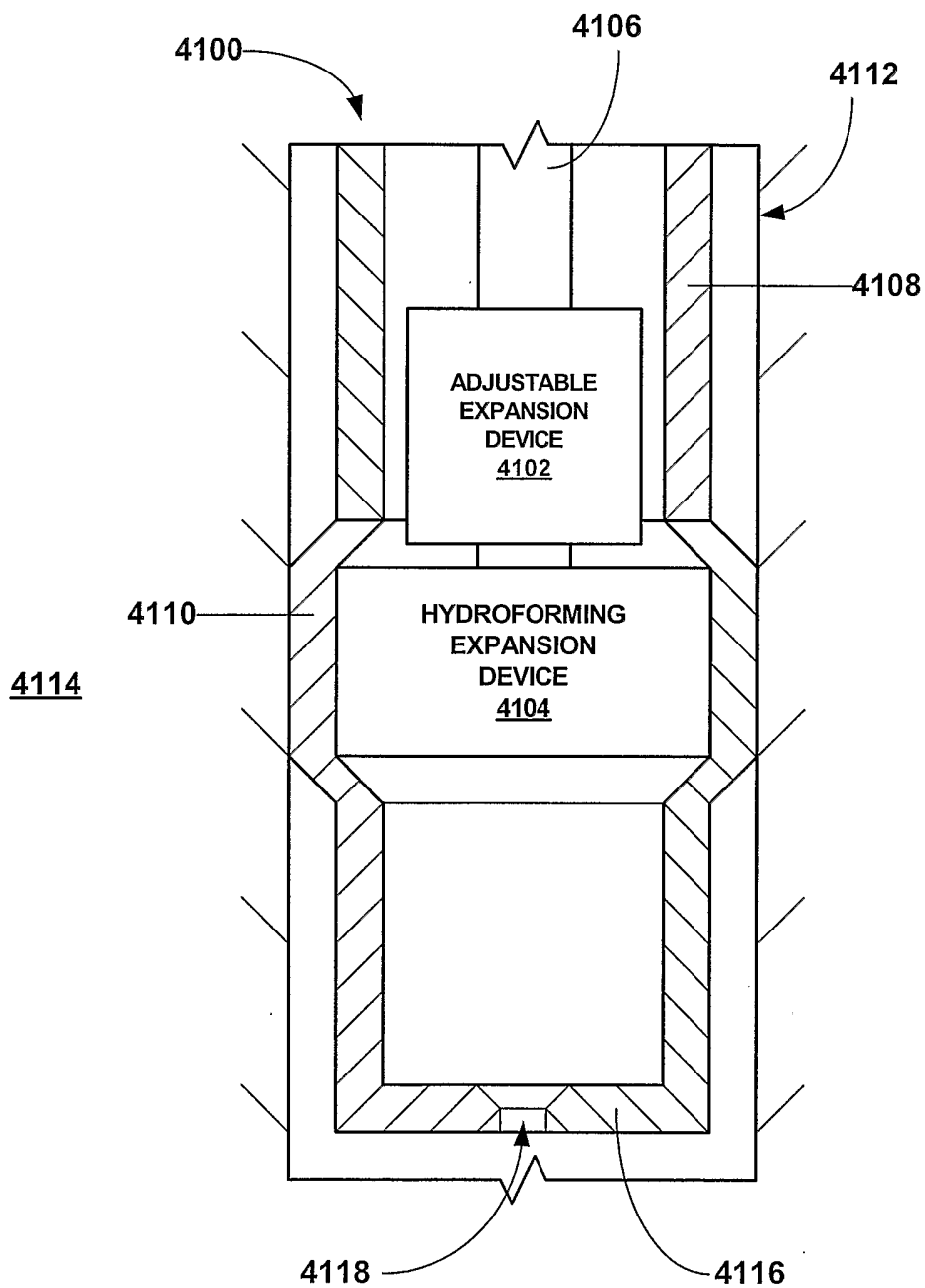

FIG. 41c

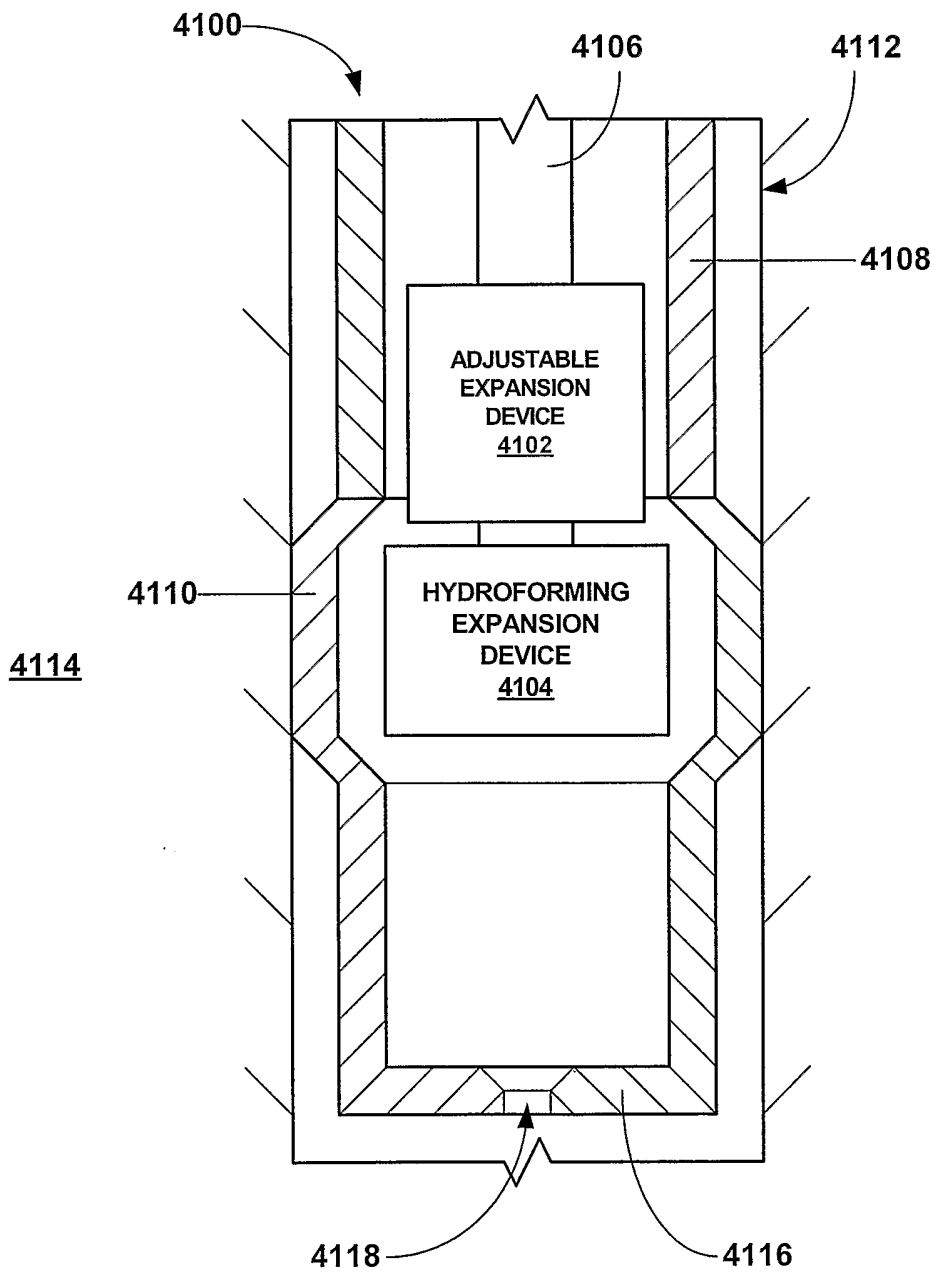

FIG. 41d

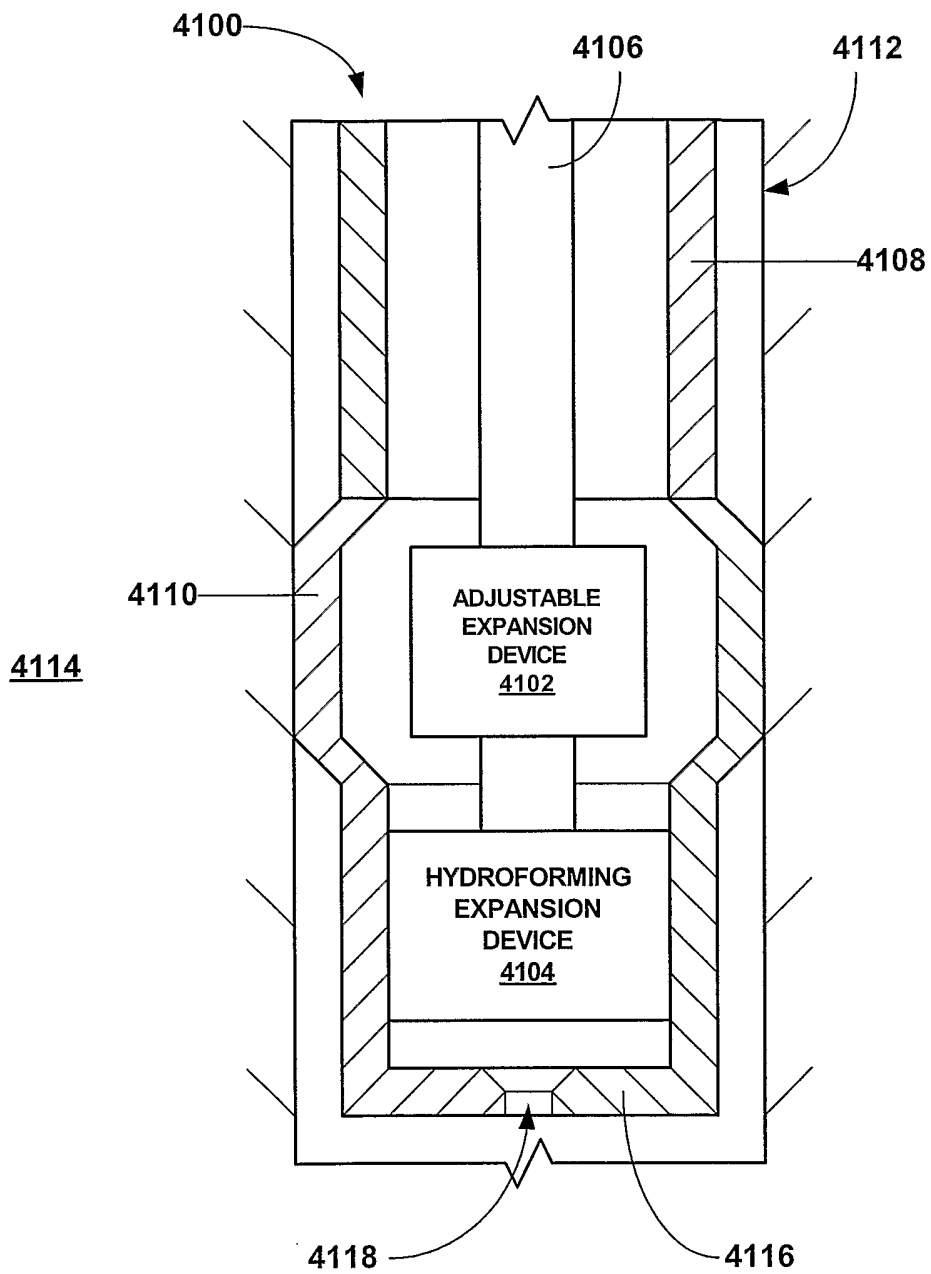

FIG. 41e

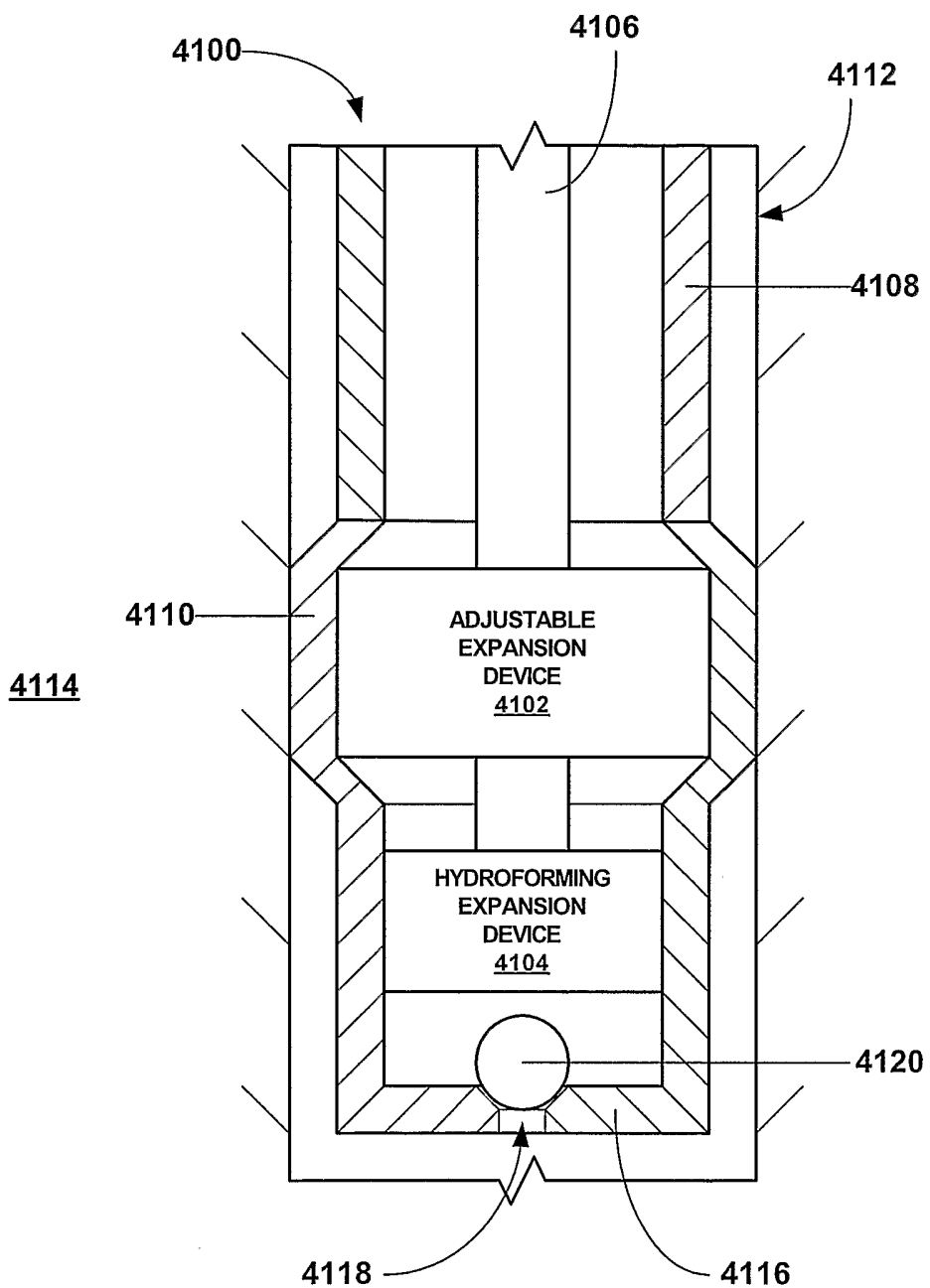

FIG. 41f

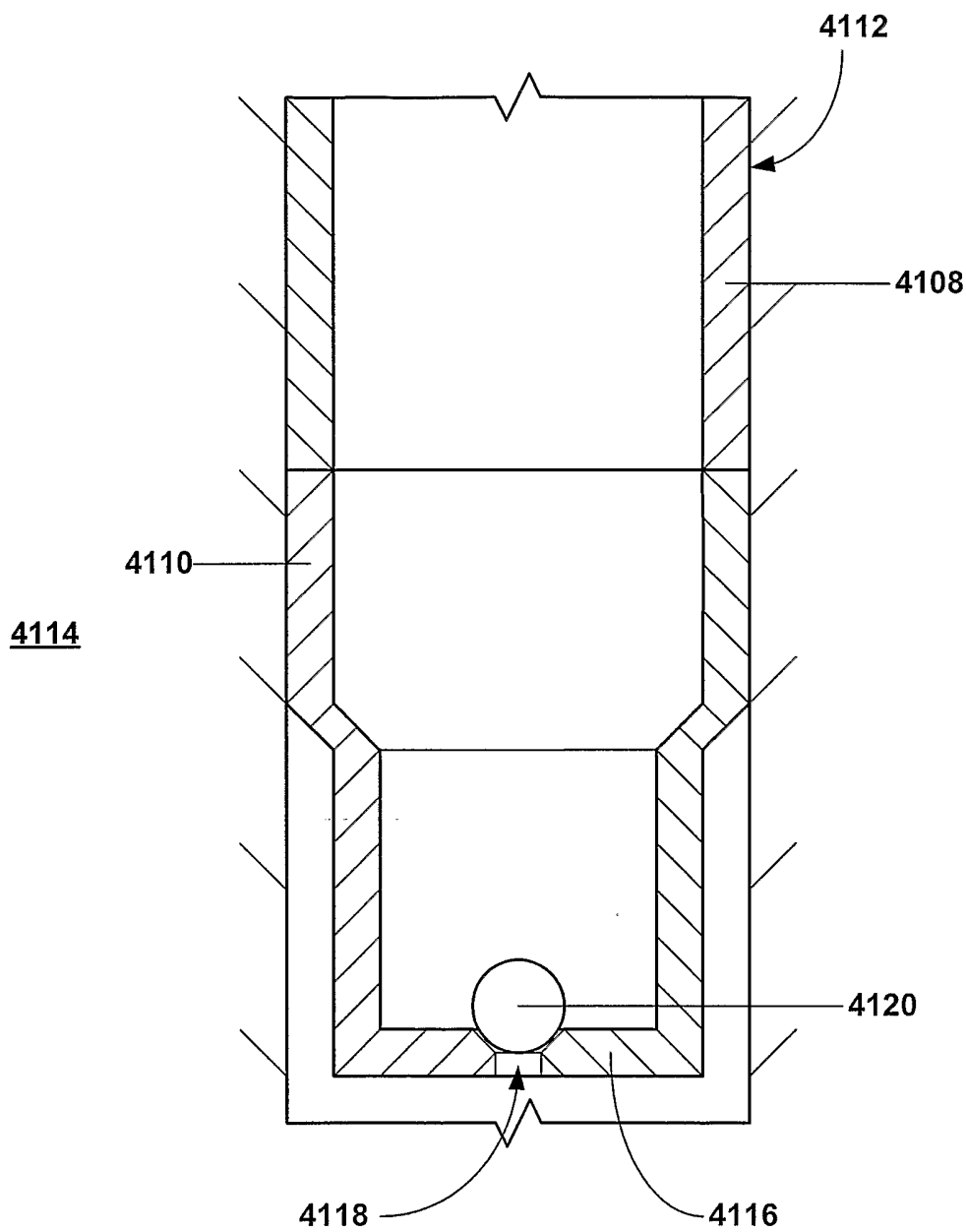

FIG. 41g

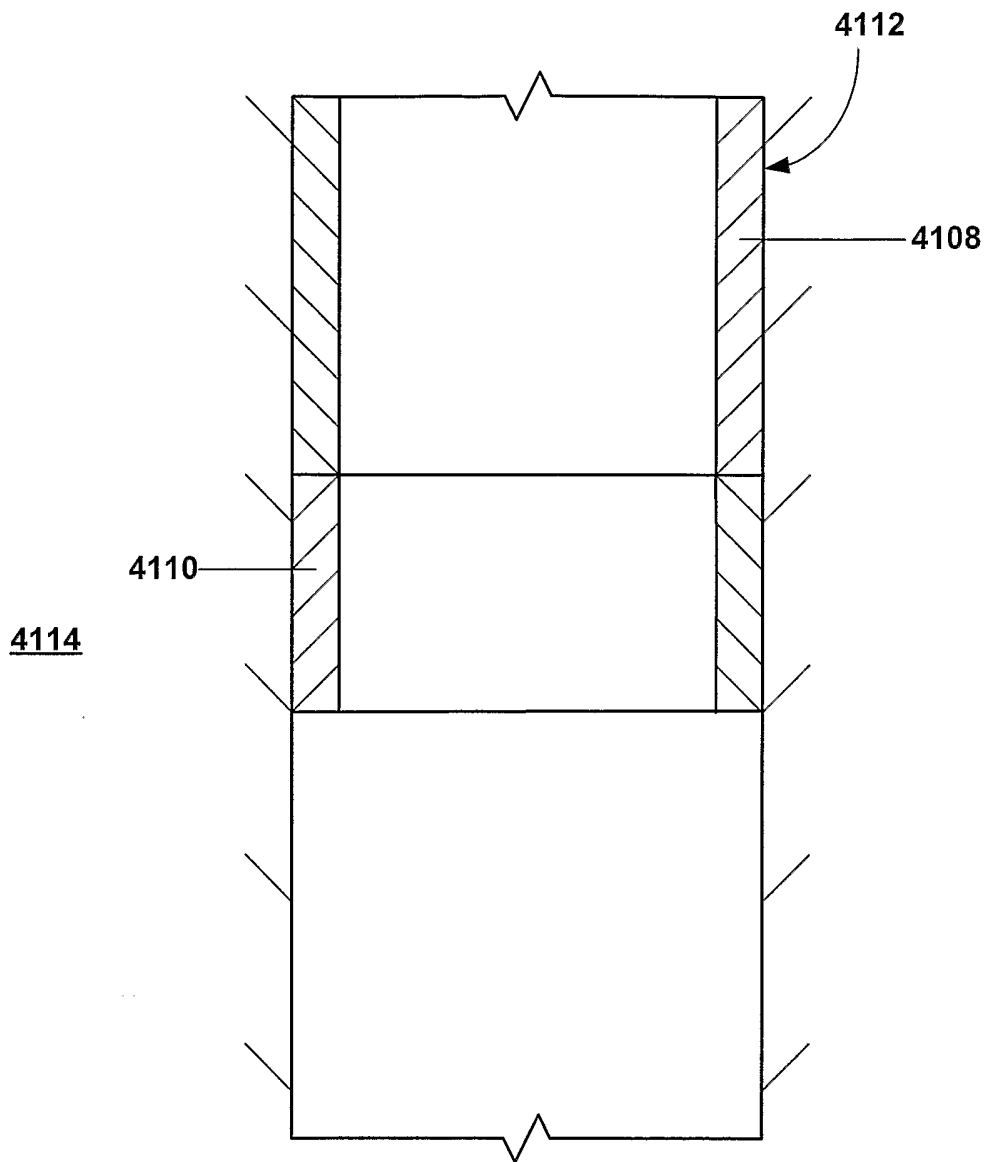

FIG. 41h

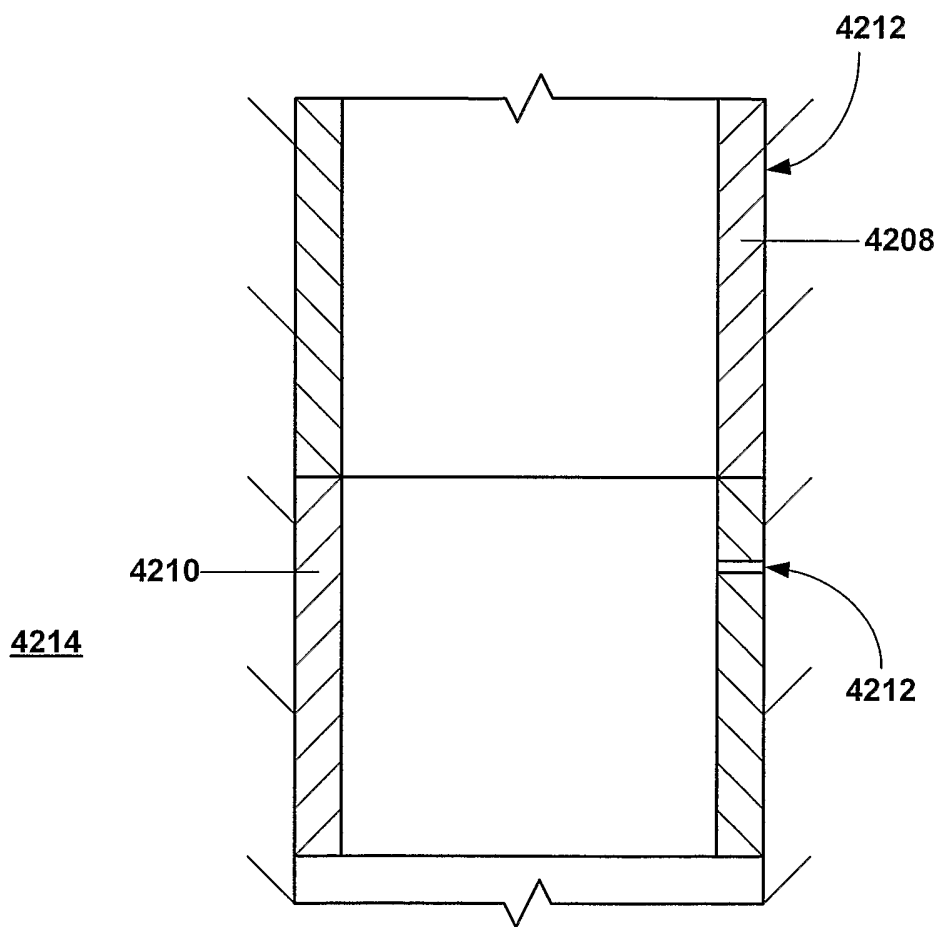

FIG. 42a

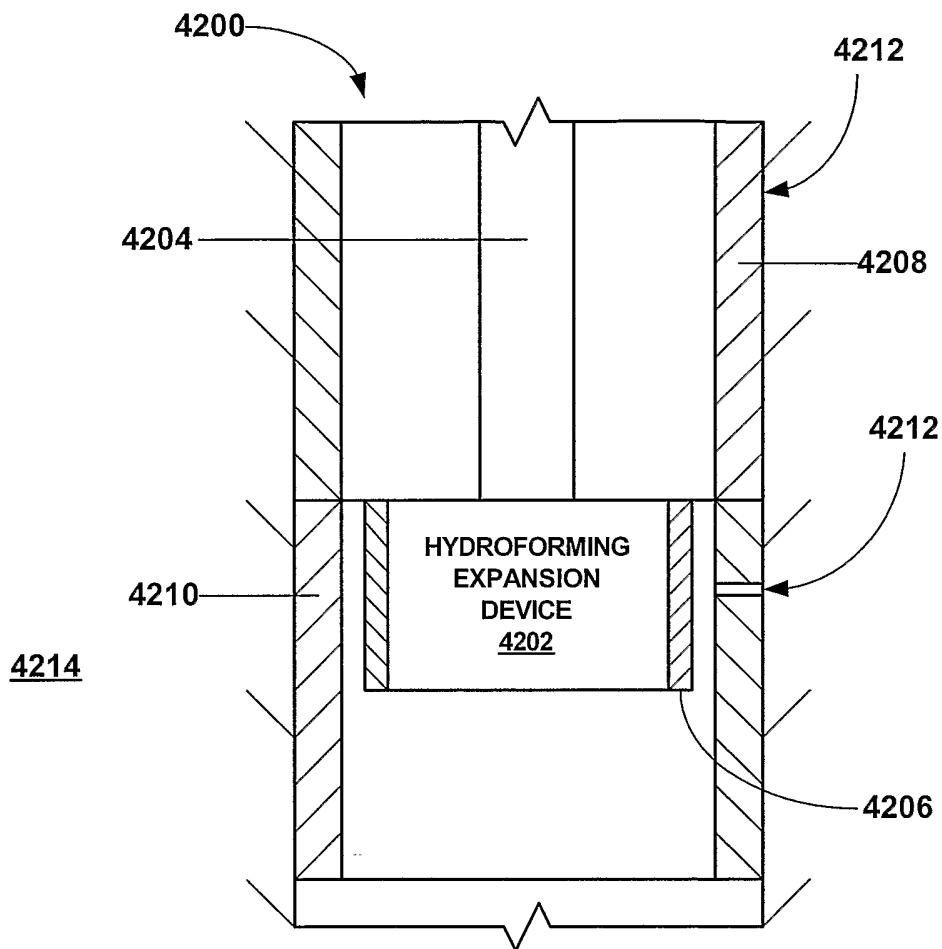

FIG. 42b

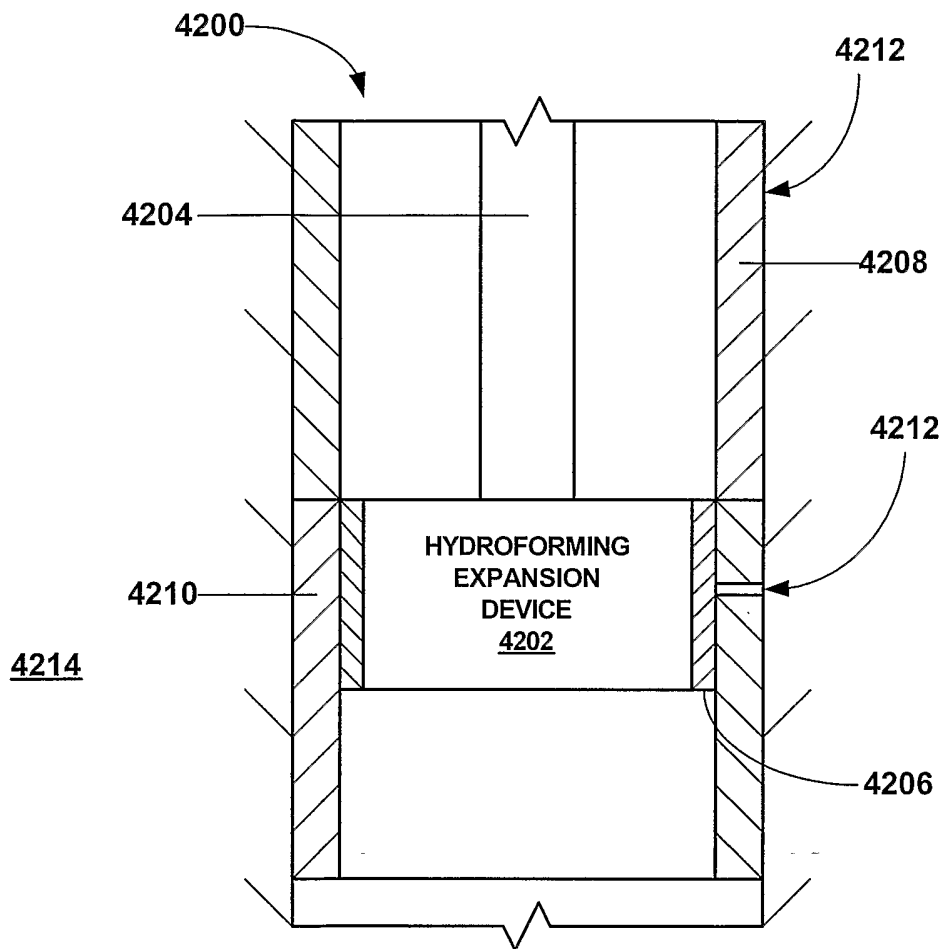

FIG. 42c

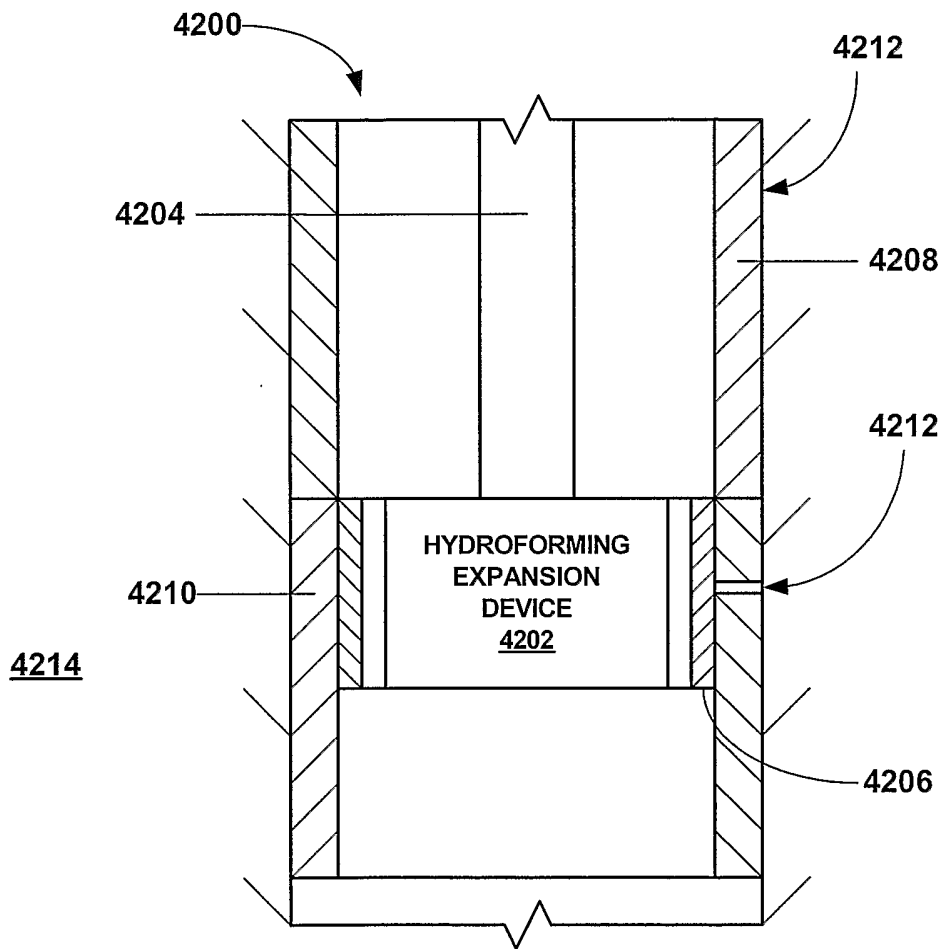

FIG. 42d

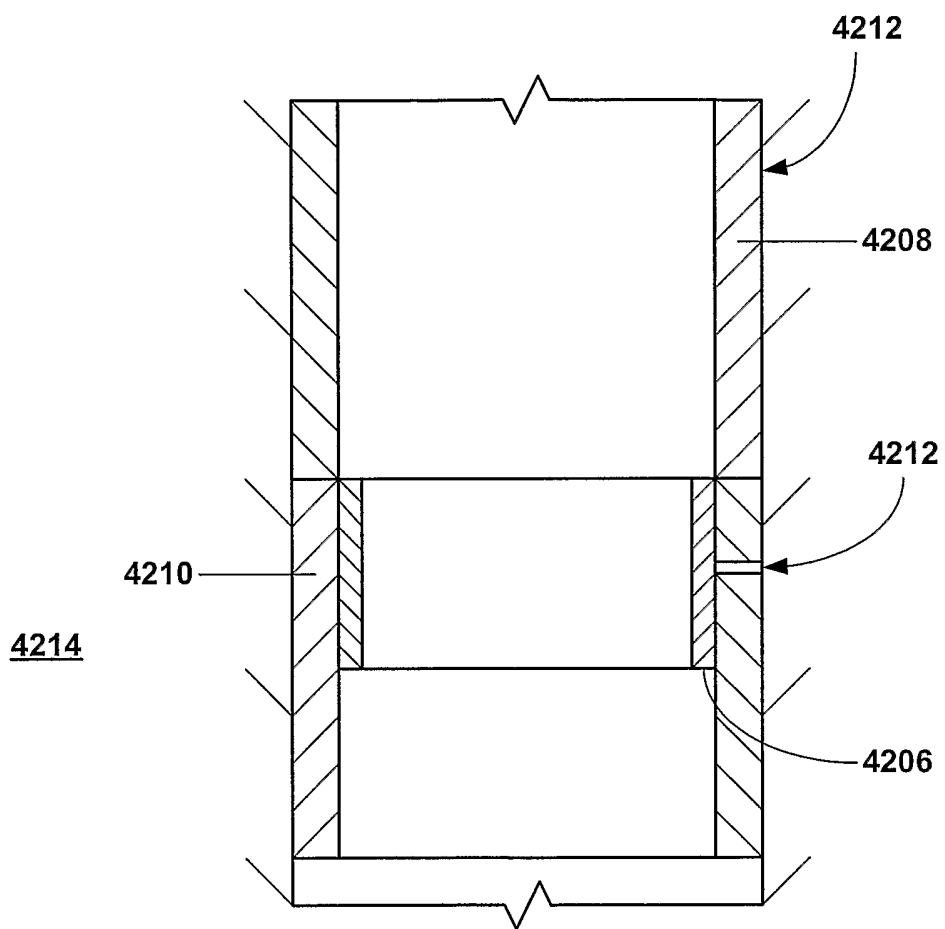

FIG. 42e

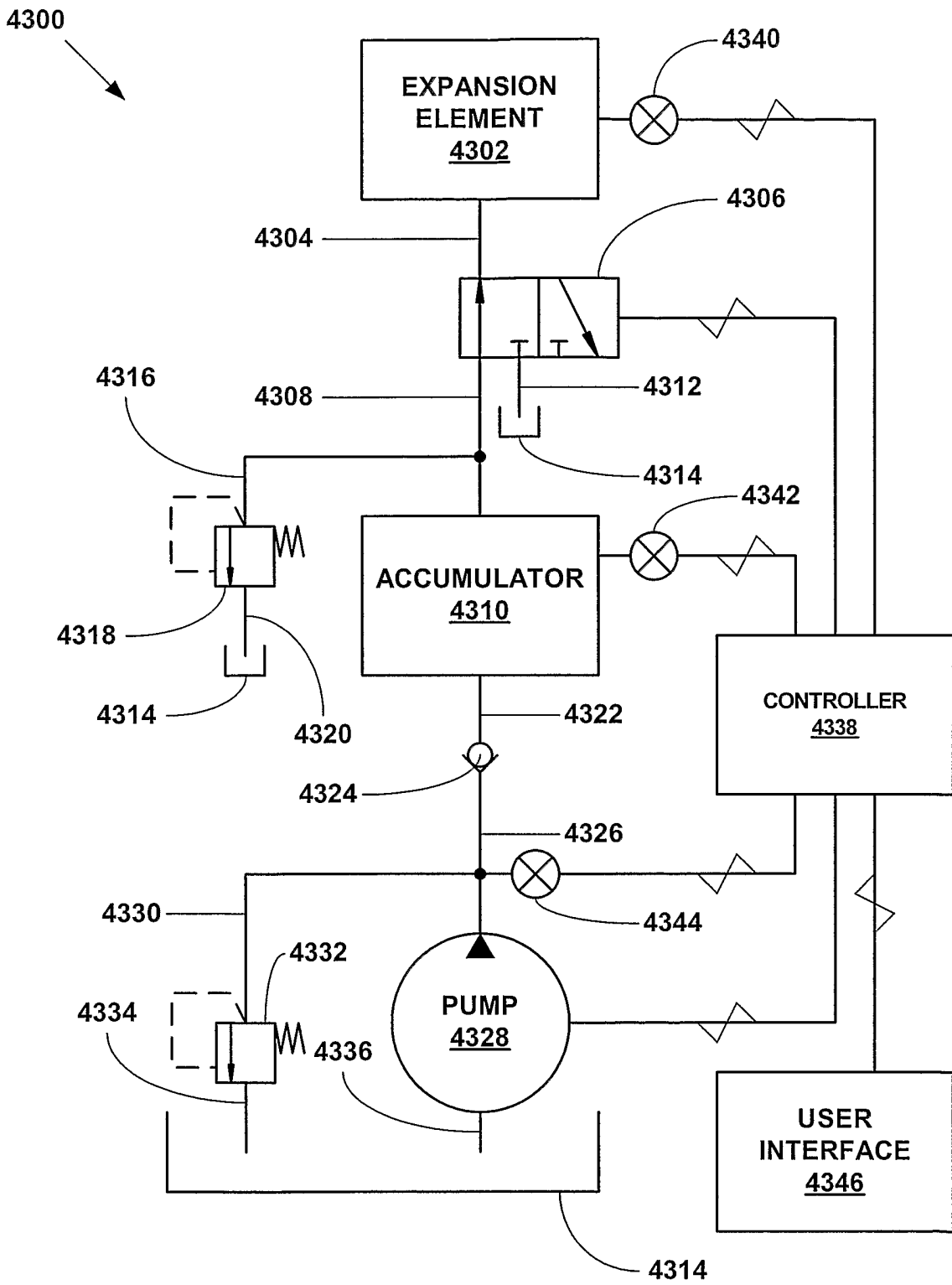

FIG. 43

4400

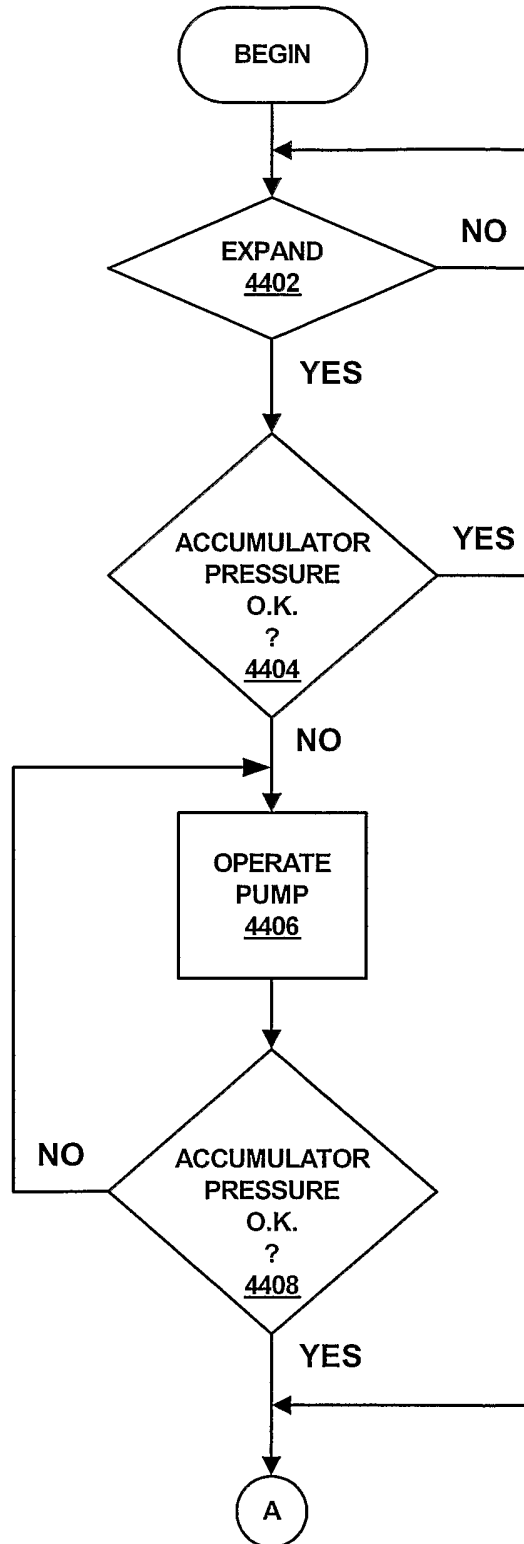



FIG. 44a

4400

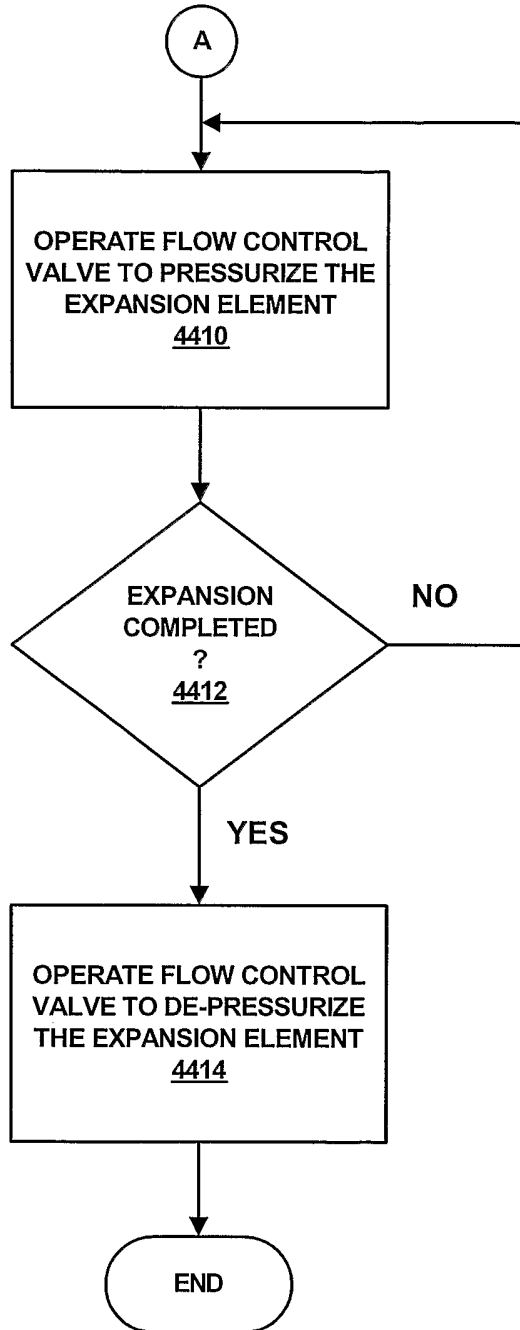
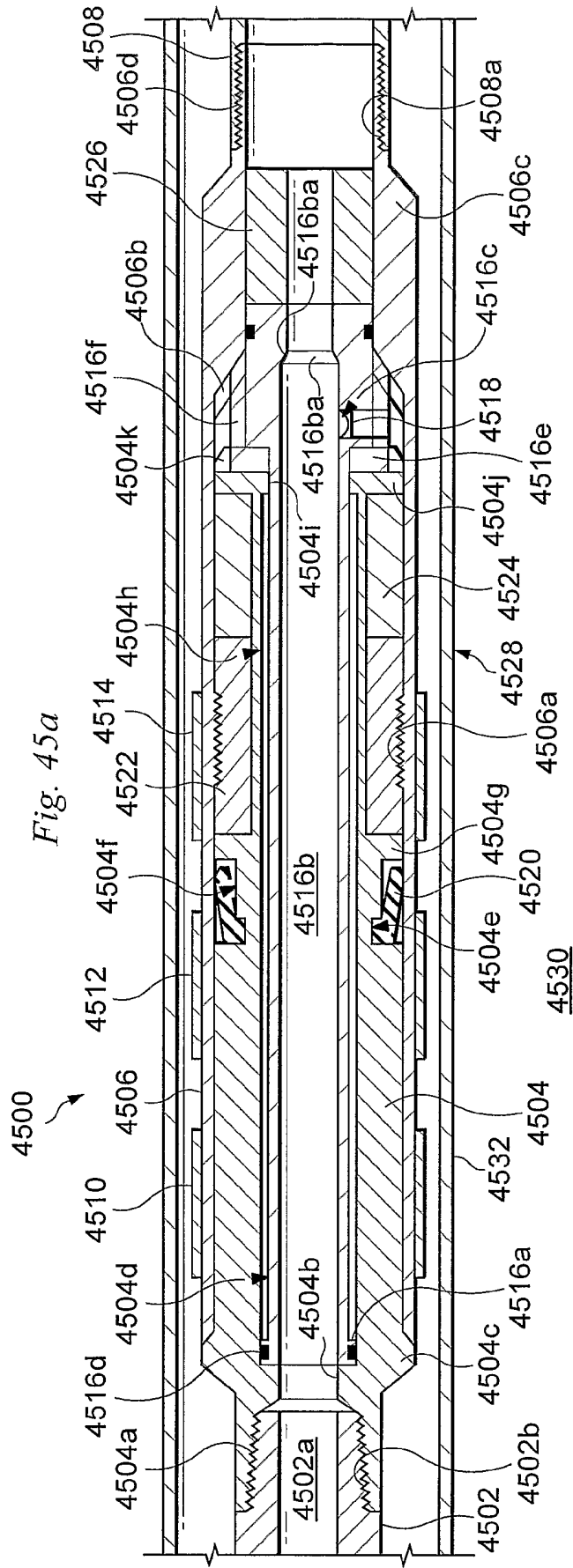
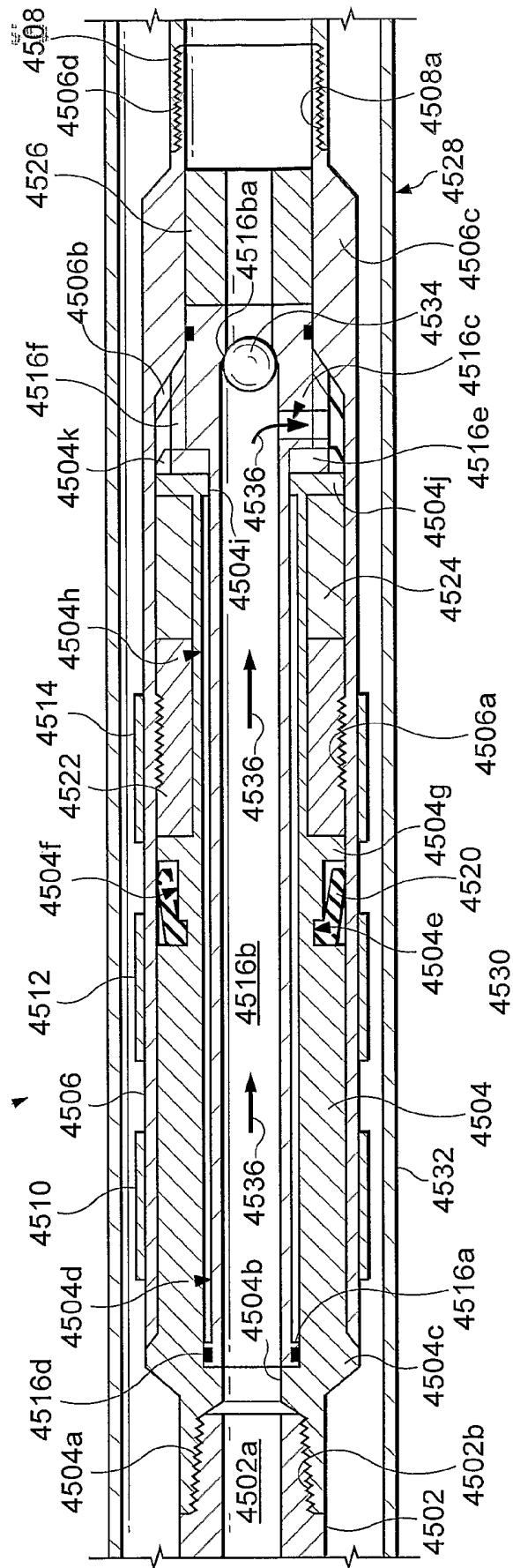
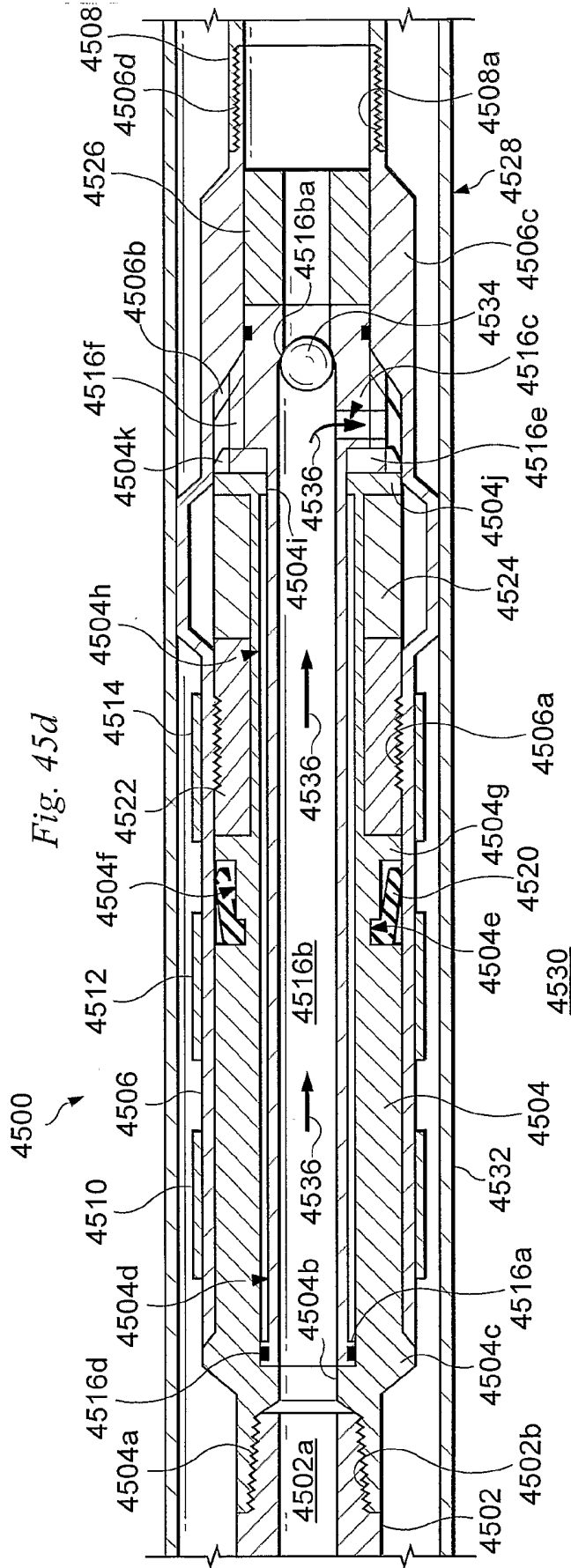
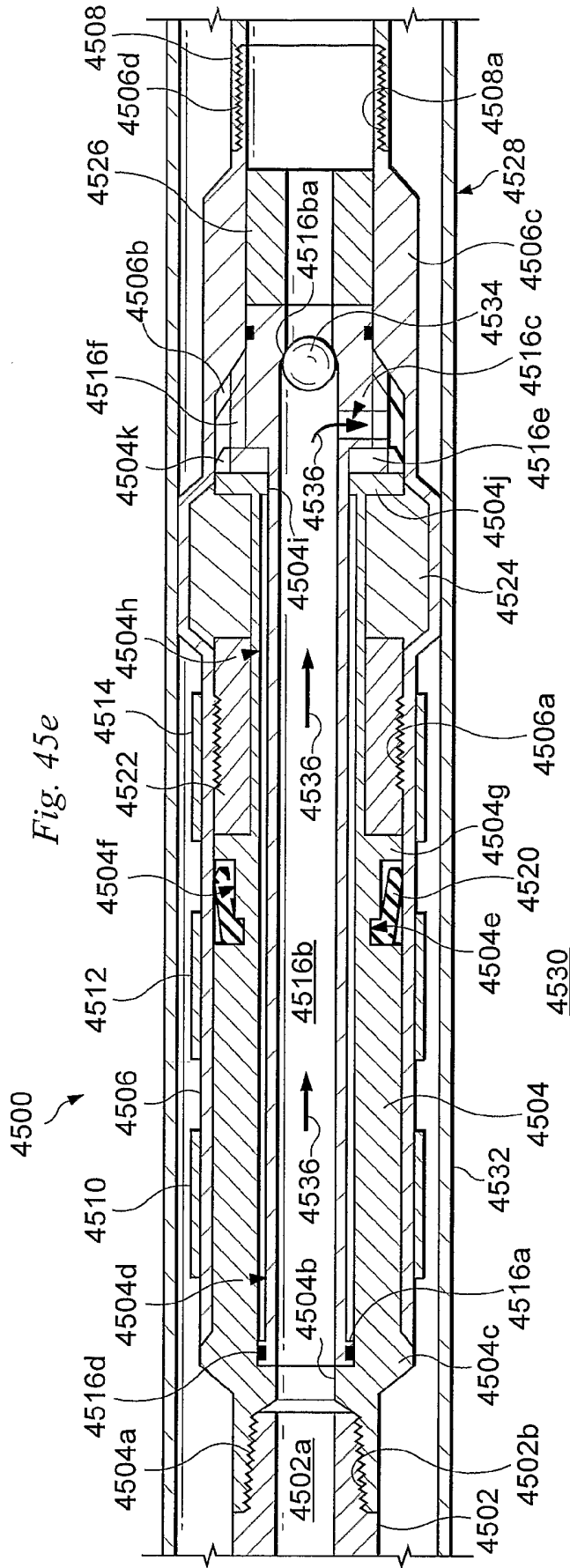

FIG. 44b









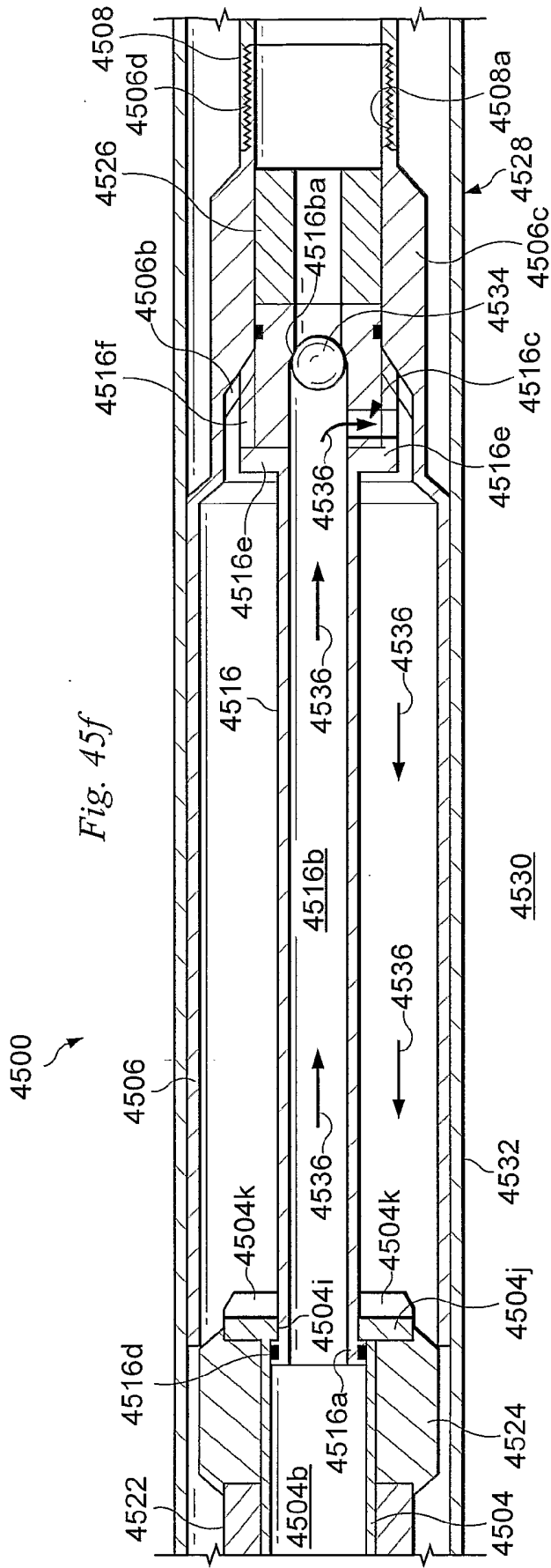
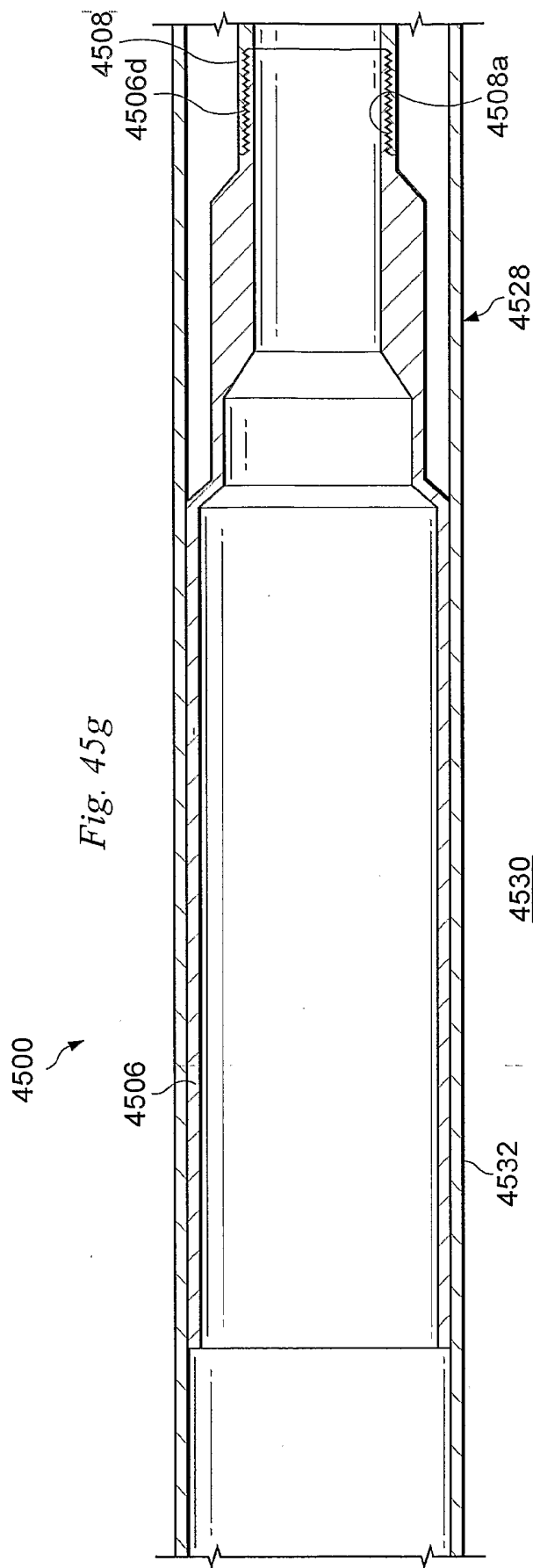

Fig. 45f



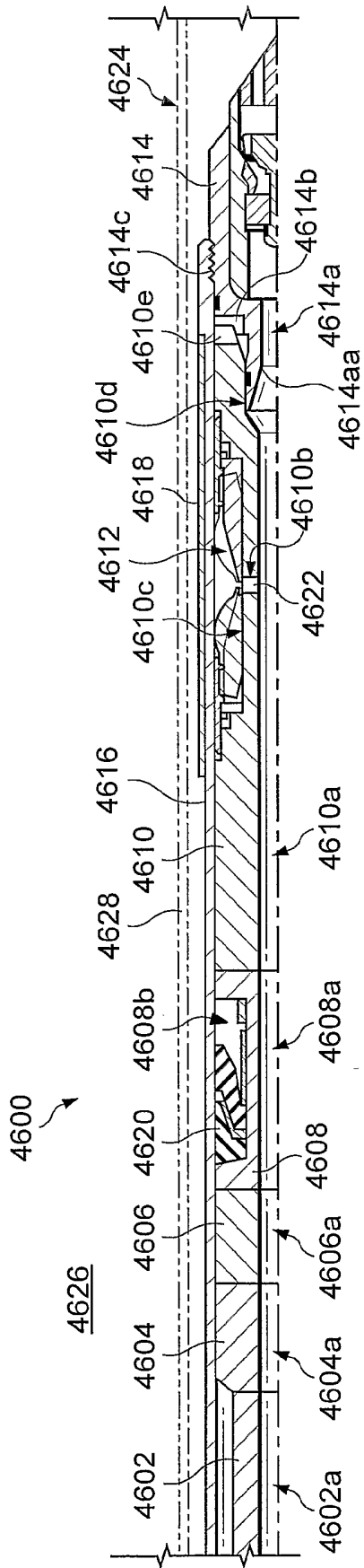

Fig. 46a

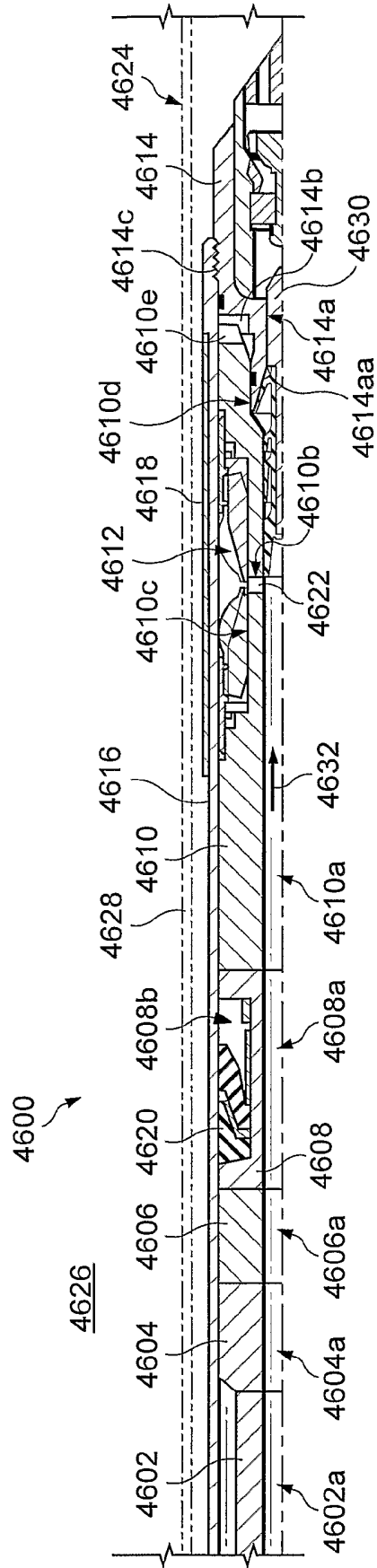

Fig. 46b

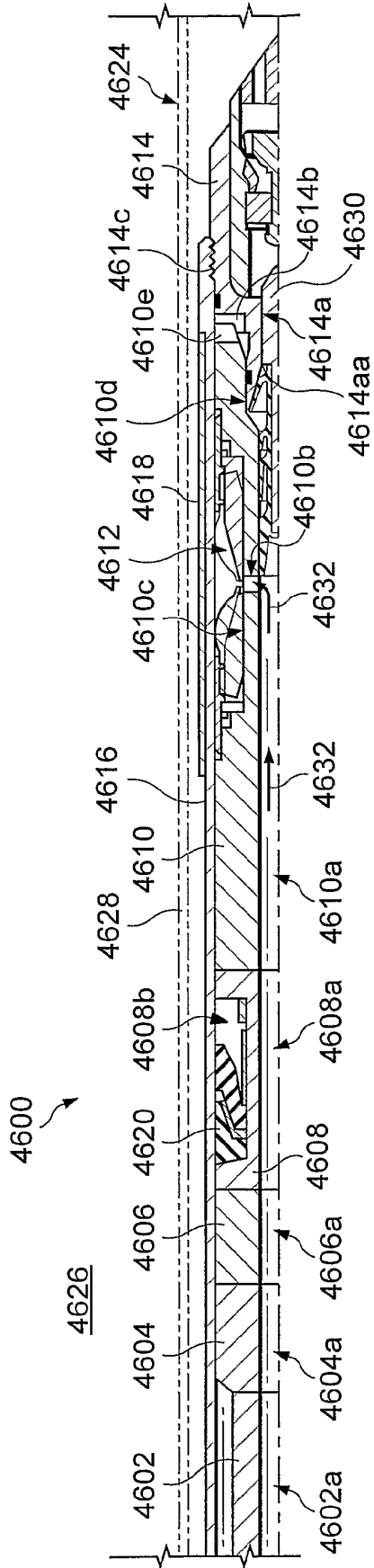

Fig. 46c

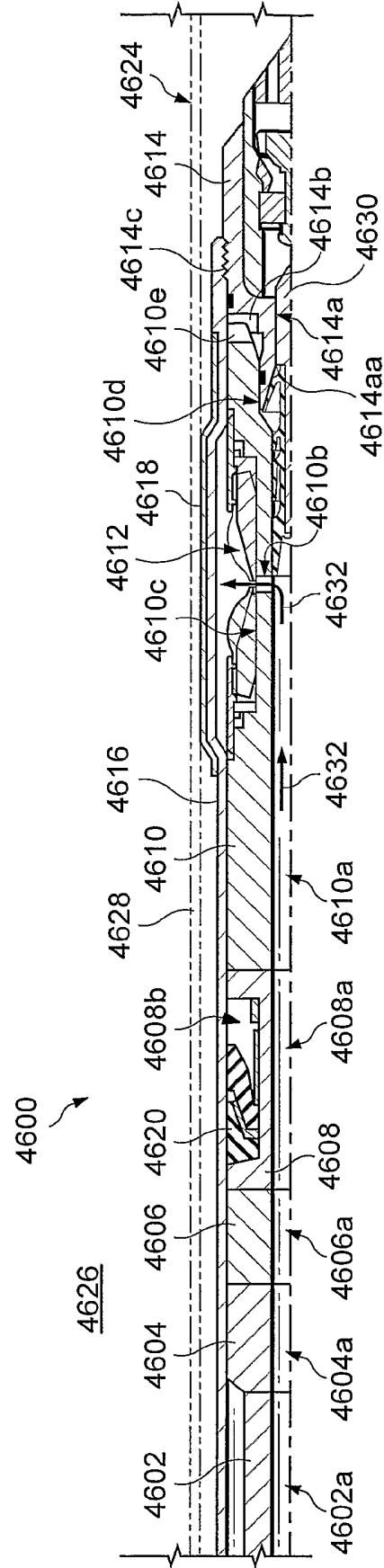

Fig. 46d

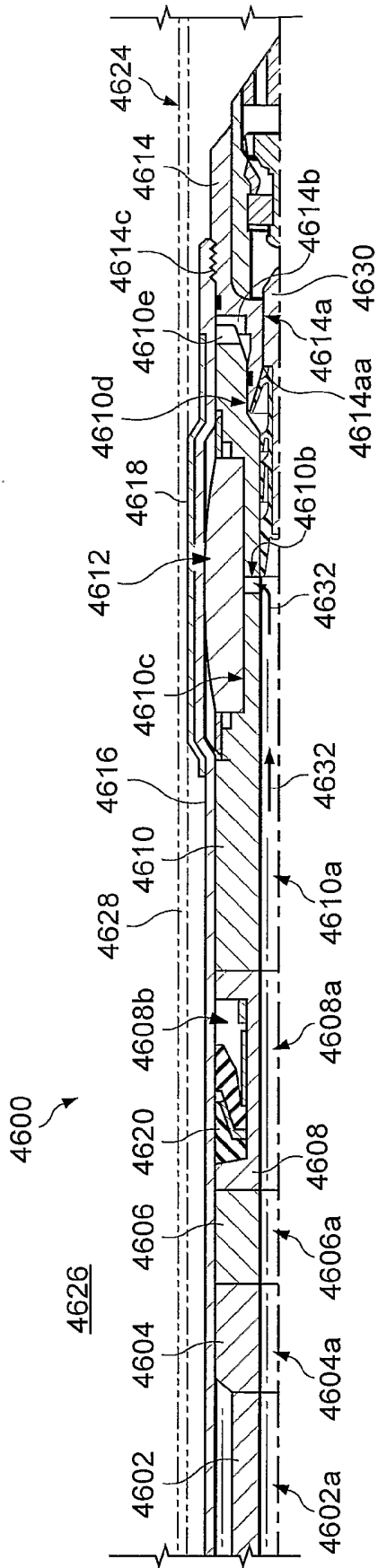

Fig. 46e

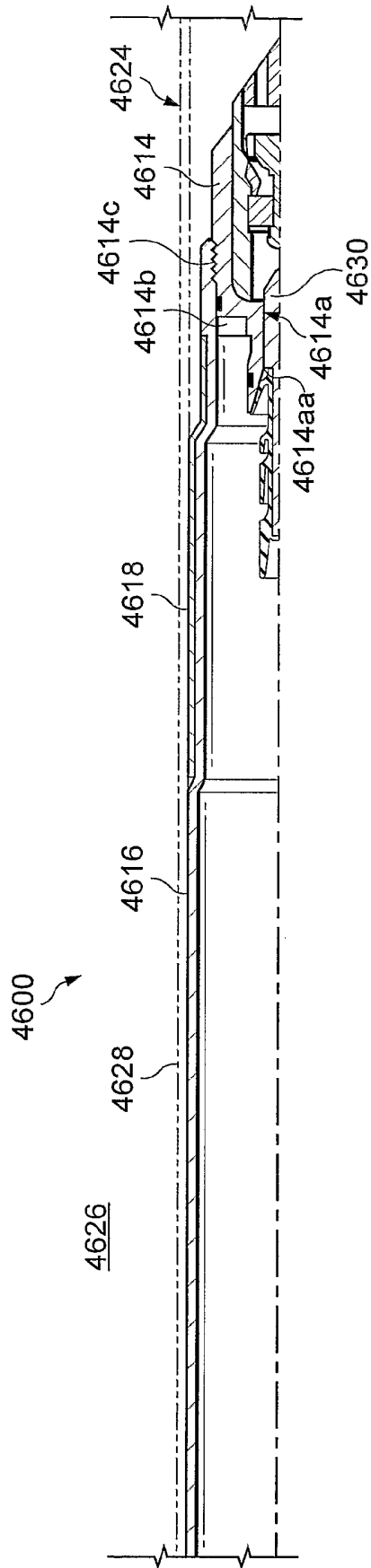

Fig. 46f

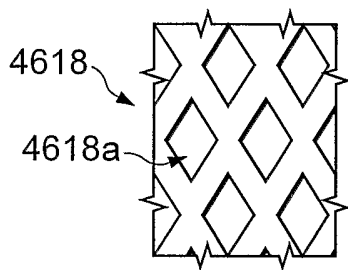

Fig. 46g

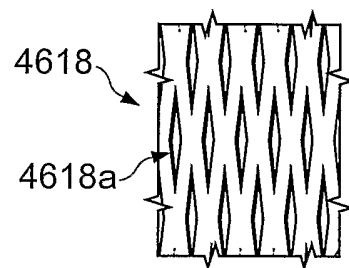

Fig. 46h

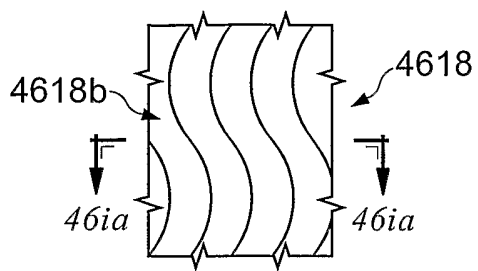

Fig. 46i

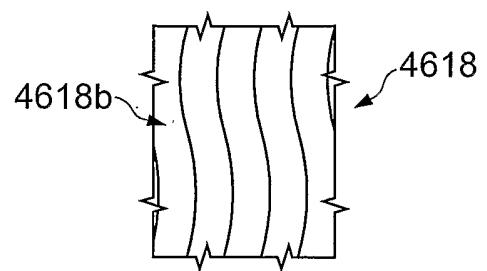

Fig. 46j

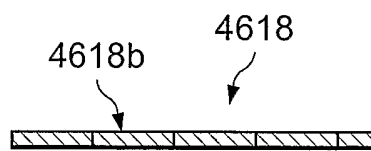

Fig. 46ia