

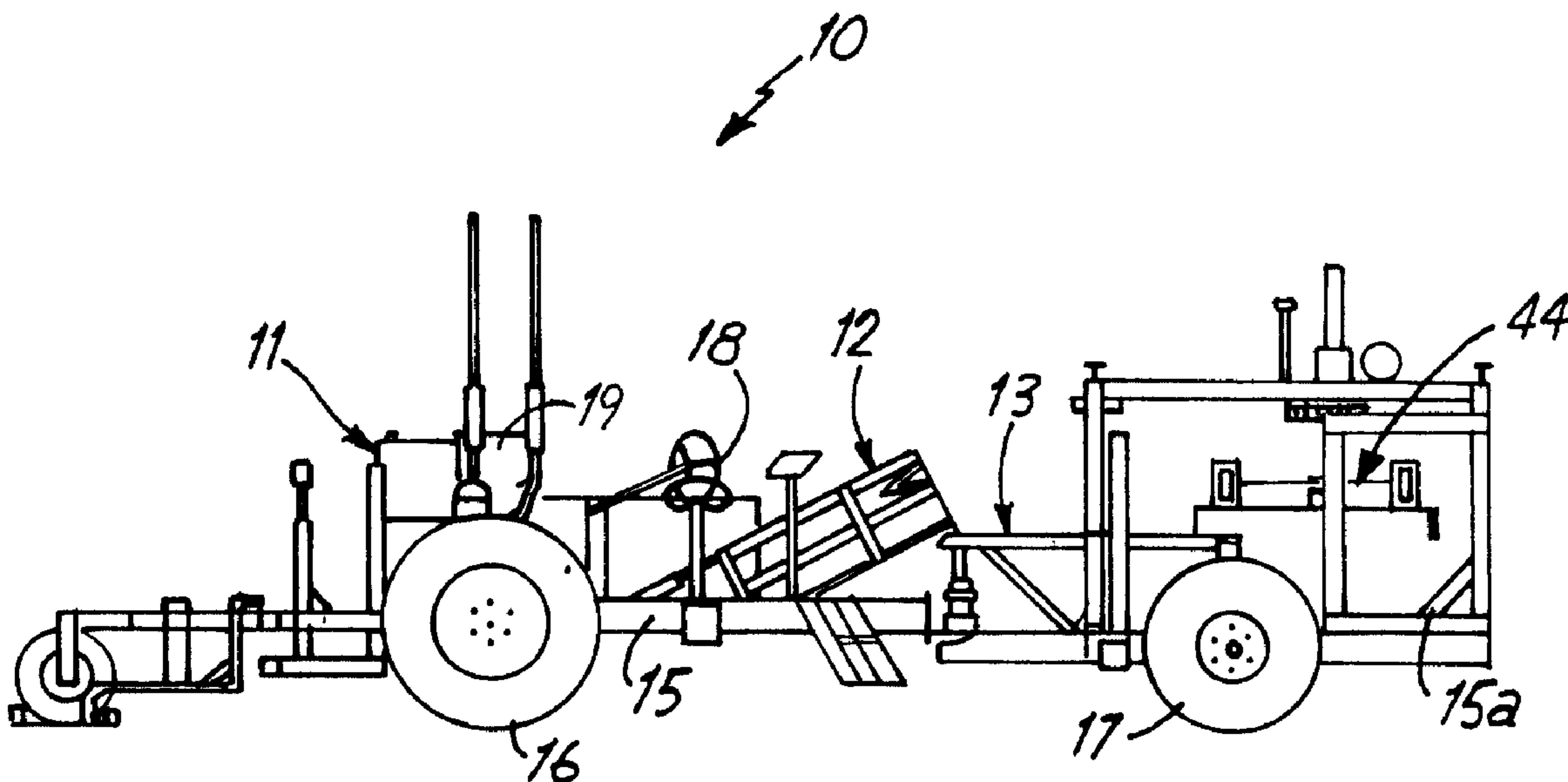

(22) Date de dépôt/Filing Date: 1999/09/27
 (41) Mise à la disp. pub./Open to Public Insp.: 2000/07/25
 (45) Date de délivrance/Issue Date: 2006/07/18
 (30) Priorité/Priority: 1999/01/25 (US09/236,170)

(51) Cl.Int./Int.Cl. *A01B 45/04* (2006.01)
 (72) Inventeurs/Inventors:
 TVETENE, DONALD, US;
 TVETENE, MICHAEL, US;
 TVETENE, GREGG, US
 (73) Propriétaires/Owners:
 TVETENE, DONALD, US;
 TVETENE, MICHAEL, US;
 TVETENE, GREGG, US
 (74) Agent: BATTISON WILLIAMS DUPUIS

(54) Titre : RECOLTEUSE DE GAZON
 (54) Title: SOD HARVESTER



(57) Abrégé/Abstract:

A method and an automatic sod harvester for on-the-go cutting, rolling and storing of sod with the sod harvester including a sod cutter for freeing a section of sod from a sod field, a sod roller for rolling the section of sod into a sod roll, a sod roll accumulator having a sod troughs therein for receiving and holding a plurality of sod rolls therein and a sod roll pickup mechanism for lifting the sod rolls on the sod roll accumulator and transferring the sod rolls to a sod carrier for delivery of the sod rolls to a remote location.

ABSTRACT OF THE DISCLOSURE

A method and an automatic sod harvester for on-the-go cutting, rolling and storing of sod
5 with the sod harvester including a sod cutter for freeing a section of sod from a sod field, a
sod roller for rolling the section of sod into a sod roll, a sod roll accumulator having a sod
troughs therein for receiving and holding a plurality of sod rolls therein and a sod roll
pickup mechanism for lifting the sod rolls on the sod roll accumulator and transferring the
sod rolls to a sod carrier for delivery of the sod rolls to a remote location.

FIELD OF THE INVENTION

This invention relates generally to sod harvesting equipment and more specifically to an on-the-go sod harvester that automatically cuts, rolls and stacks sod for machine pickup of the stacked sod.

BACKGROUND OF THE INVENTION

The concept of sod harvesting is old in the art. Typically, a sod slab is cut free from a sod field. The slab is then rolled up into a cylindrical roll that is transferred to a pallet or a sod pickup mechanism. If the sod rolls are "small rolls", the sod rolls can be manually transferred to a sod delivery truck that delivers the sod to the area where the sod rolls are to be laid. If the sod rolls are "big rolls", it is necessary to use equipment to both lift and transfer the sod rolls. Numerous devices are available for mechanizing portions of the sod harvesting and delivering process. For example, U.S. patent 5,230,602 shows a sod roll stacker for stacking rows of small rolls. Still other devices are available for cutting and rolling both small rolls and big rolls. The present invention comprises an apparatus and method that is suitable for automatic on-the-go cutting, rolling and stacking of small rolls of sod in a ready to transport condition.

SUMMARY OF THE INVENTION

Briefly, the present invention comprises a method of on-the-go cutting, rolling and stacking sod and an on-the-go sod harvester for automatically cutting, rolling and storing sod with the sod harvester including a sod cutter for freeing a section of sod from a sod field, a sod roller for rolling the section of sod into a sod roll, a sod roll accumulator having a set of sod troughs therein for receiving and holding the sod roll therein and a sod roll pickup mechanism for lifting the sod roll on the sod roll accumulator and stacking the sod roll on a sod carrier for later pick-up.

According to first aspect of the invention, there is provided a sod harvester for on-the-go cutting, rolling and storing of sod comprising:

a sod cutter for freeing a section of sod from a sod field;

a sod roller for rolling the section of sod into a sod roll;

5 a sod roll accumulator, said sod roll accumulator having a sod trough therein for receiving and holding the sod roll therein;

a sod roll pickup mechanism for lifting the sod roll on the sod roll accumulator and transferring the sod roll to a sod carrier.

10 According to second aspect of the invention, there is provided a sod harvester for on-the-go cutting, rolling and storing of sod comprising:

a sod cutter for freeing a plurality of sections of sod from a sod field;

a sod roller for rolling each of the plurality of sections of sod into a sod roll;

15 a sod roll accumulator, said sod roll accumulator having a set of sod troughs therein for receiving and holding a plurality of sod rolls therein; and

a sod roll pickup mechanism for lifting the plurality of sod rolls on the sod roll accumulator and transferring the plurality of sod rolls to a sod carrier.

20 According to third aspect of the invention, there is provided the method of on-the-go harvesting of sod comprising the steps of:

cutting a slab of sod;

rolling the cut slab of sod into a sod roll;

placing the sod roll onto a sod accumulator while waiting for at least one more roll of sod to be placed in the sod accumulator to form a plurality of sod rolls; and

25 removing the plurality of sod rolls from the sod accumulator and stacking the plurality of sod rolls.

BRIEF DESCRIPTION OF THE DRAWINGS

Figure 1 is a side elevation of the on-the-go sod harvester for the automatic cutting, rolling and storing of sod;

5

Figure 2 is a partial schematic view showing the cutter and the sod roller for rolling a sod slab into a sod roll;

Figure 3 shows a side view of the sod accumulator for receiving a set of sod rolls taken

1 0 along lines 3-3 of Figure 4;

Figure 4 shows a top view of the sod accumulator of Figure 3;

Figure 5 shows a top view of the sod roll pickup mechanism with the retractable spikes for

1 5 piercing engagement with a set of sod rolls;

Figure 6 is a side view showing the sod roll pickup mechanism with the retractable spikes in the retracted position;

2 0 Figure 7 is a side view showing the sod roll pickup mechanism with the retractable spikes in the extended position;

Figure 8 is an end view of the sod roll pickup mechanism with the retractable spikes in the retracted condition;

2 5

Figure 9 shows an end view of the sod roll pickup mechanism in the extended position;

Figure 10 is the end view of the sod roll pickup mechanism shown in Figure 9 with a plurality of sod rolls suspended thereunder;

Figure 11 shows the sod rolls stacked in alternate layers on the on-the-go sod harvesting machine of Figure 1; and

Figure 12 is a schematic mechanism to indicate the axial rotation of the sod pickup mechanism to enable placement of sod rolls in alternate rows.

1 0 **DESCRIPTION OF THE PREFERRED EMBODIMENT**

Figure 1 is a side view of the on-the-go sod harvester 10 for the automatic cutting, rolling and storing of sod. The sod harvester includes a sod cutting mechanism 11 for freeing a section of sod from a sod field, a sod roller 12 for rolling the section of sod into a sod roll, a sod roll accumulator 13 having sod troughs therein for receiving and holding the sod roll
1 5 therein, a sod roll pickup mechanism 14 for lifting the sod roll onto the sod roll accumulator 13 and transferring the sod roll to a sod carrier 15a for delivery of the sod roll. The sod cutting mechanism 11, the sod roller 12, the sod roll accumulator 13, the sod pickup mechanism 14, and the sod carrier 15a are supported on a frame 15. The frame 15 has a set of front wheels 16 and a set of rear wheels 17 and an operator's console 18
2 0 together with a motor 19 for driving the sod harvesting machine over a sod field. A feature of the present invention is that the operator performs the function of driving the sod harvester over the turf field but the cutting, rolling and storing of sod are accomplished automatically without any required input from the operator. If desired, the operator can interfere with the automatic process and manually override portions of the process using the
2 5 operator's console 18. However, in the preferred embodiment, the automatic operations are preferred since they require an operator with less skill.

Figure 2 is a partial schematic view showing the sod cutting mechanism 11 having a vertical cutoff blade 21 and a horizontal cutting blade 22 for freeing a slab of sod 23 from turf 9. A set of side cutters (not shown) free the edges of sod slab 23. The process and apparatus for cutting and freeing a slab of sod from a turf field is well known in the art

5

Figure 2 is a side view that illustrates the apparatus and process of rolling a sod slab into a sod roll. A sod slab 24 which has a partially rolled end 24a is shown on the lower end of sod roller 12. In operation, the sod slab 24 is elevated by a rotatable belt 26 that is located at an angle and is supported and driven by roller 28 which is powered by sod harvester 10.

1 0 Located above sod belt 26 is a friction member 29 that is held in pressure engagement with the sod on belt 26 by the resilient members 30 and 31. Friction member 31 is free to move laterally toward and away from rotatable belt 26 but is prevented from moving in the direction of belt travel by restraining members (not shown). In operation of the sod roller 12, the underside 29a of member 29 frictionally engages the leading end of sod slab 24 to
1 5 initiate rolling of sod slab into a roll as indicated by numeral 24a. A further sod slab 25, which is located at the top of rotatable belt 26 is shown in a rolled condition. The rolled sod 25 is rotating in a counter clockwise direction, as indicated by the arrow, and will be elevated up and over the sprocket 28 so that the sod rolls can be dropped into the sod accumulator 13.

2 0

Figure 3 shows a side view of the sod accumulator 13 for receiving a set of sod rolls shown in Figure 3 as taken along lines 3-3 of Figure 4, which shows a top view of the sod accumulator 13. The sod roll accumulator 13 includes a plurality of flexible belts 40 that are supported at spaced, lateral intervals by fixed engagement with cross members 42. The
2 5 belts hang down between the cross members 42 to form a set of parallel spaced sod troughs 40a for receiving and holding a plurality of sod rolls in side by side and end to end condition. A first chain 49 engages one end of bars 42 and a second chain 48 engages the

opposite end of bars 42 with one end of bar 42 supported by a track 37a and the other end
of the bars 42 supported by a track 37. A first drive roller 46 and a second drive roller 45
intermittently rotate belts 40 through a power mechanism (not shown). In operation of the
sod roll accumulator 13, the belts 40 are stationary as the sod rolling mechanism 11 drops a
5 roll of sod into the sod trough 40a on the left end of sod accumulator 13. Once sod trough
40a is filled with a row of sod rolls 30, 30a and 30b the drive mechanism rotates the drive
chains 48 and 49 sufficiently to move sod rolls 30, 30a and 30b into the spatial position
occupied by sod rolls 31, 31a, and 31b. Similarly sod rolls 31, 31a, and 31b are moved
into the spatial position occupied by sod rolls 32, 32a and 32b and sod rolls 32, 32a and
1 0 32b are moved into the spatial position to the right of sod roll 32. Thus, each of the sod
rolls advance one position ,thus freeing the sod trough 40a proximate the right end of roller
48 to receive another row of sod rolls. This process continues until all the accumulator sod
troughs 40a are filled with sod rolls. When the sod troughs 40a are filled with sod rolls,
the sod rolls are in a ready condition to be transferred and stacked. In the embodiment
1 5 shown, the flexible belts 40 extend downward in a catenary curve between adjacent bars
42.

It will be envisioned that sod harvesting including the cutting, rolling and accumulation of
sod rolls is accomplished while the sod harvester 10 is on-the-go and without operator
2 0 input. That is, as sod harvester 10 moves forward, the sod slab is cut, rolled and stored
without the necessity of having the operator manually perform any of the steps of the sod
harvesting operation.

While the invention is shown with multiple sod rolls in each of the troughs in the
2 5 accumulator, it is envisioned that a single sod roll could be placed in each trough. In
addition although five troughs are shown, it is further envisioned that one or more sod
troughs could be used in my sod accumulator.

Figure 5 shows a schematic top view of the sod roll pickup mechanism 14 which includes a frame 50 with a first set of retractable spikes comprised of a first row of spikes 60 and a second row of spikes 61 and a second set of retractable spikes comprised of a first row of spikes 70 and a second row of spikes 71. The retractable spikes are slideable laterally along guides (not shown) to form a piercing engagement with a set of sod rolls located on accumulator 13.

The retractable spikes are extended and retracted by a power drive mechanism 51 that is mounted on frame 50. Power drive mechanism 51 rotates a double sprocket wheel 51a which is connected to sprocket wheel 53a through chain 53 and similarly to sprocket wheel 52a through chain 52.

In operation of the sod roll pickup mechanism 14, the sprocket wheel 51a is rotated in a first direction to extend the retractable spikes and in the opposite direction to retract the retractable spikes. Figure 6 is a side view showing the sod roll pickup mechanism 14 with the two sets of retractable spikes in the retracted position and Figure 7 is a side view showing the sod roll pickup mechanism 14 with the retractable spikes in the extended position.

In the operation of the sod roll pickup mechanism, the rotation of sprocket wheel 51a simultaneously rotates chain 53 and chain 52. The rotation of chain 53 in a first direction causes rotation of sprocket wheel 53a which in turn rotates shaft 53b. The rotation of shaft 53b rotates chains 55, 54, 56 and 57. As one set of spikes are mounted to the upper portion of the rotating chains and the other to the lower portions of the rotating chains the rotation of the chains cause the set of spikes to extend and retract in unison. A first bar 59 connected to chains 55 and 56 holds retractable spikes 60 and a second bar 58 connects to

chains 57 and 54 so that rotation of chains 54, 55, 56, and 57 slides spikes 60 and 61 downward to the position shown in Figure 7. The rotation of chain 53 in the opposite direction causes rotation of sprocket wheel 53a in the opposite direction which in turn rotates shaft 53b in the opposite direction. The rotation of shaft 53b in the opposite direction also rotates chains 55, 54, 56 and 57 in the opposite direction. Consequently, the first bar 59 which is connected to chains 55 and 56 slides upwards to retract retractable spikes 60 and the second bar 58 which is connects to chains 57 and 54 also slides upward so that rotation of chains 54, 55, 56, and 57 in the opposite direction moves spikes 60 and 61 upward into the position shown in Figure 7. As the two sets of retractable spikes operate in an identical manner, only one set of retraceable spikes is described herein. Each set of spikes comprises cylindrical members having a pointed end for piercing the sod roll. The spikes are spaced sufficiently close so that multiple spikes will engage a sod roll to hold the sod roll during the pickup and transfer process.

Figure 8 is an end view of the sod roll pickup mechanism 14 with the retractable spikes in the retracted condition. It should be pointed out that the sod roll pickup mechanism is an overhead mechanism for picking up sod rolls from above rather than from below.

Figure 9 shows an end view of the sod roll pickup mechanism 14, while empty.

Figure 10 is the end view of the sod roll pickup mechanism 14 shown in Figure 9 with a plurality of sod rolls 90, 91, 92, 93 and 94 suspended thereunder for movement and placement of the sod rolls on a stack. In operation of sod roll pickup mechanism 14, the sod roll pickup mechanism 14 is normally located in the open condition illustrated in Figure 8. Next, the sod roll pickup mechanism is lowered onto the top of a layer of sod rolls that are located on the sod roll accumulator 13.

Figure 10 shows the sod roll pickup mechanism 14 located on top of sod rolls 90, 91, 92, 93 and 94. Once the sod rolls are in position, the sets of retractable spikes 60, 61, 70 and 71 are extended downward at an angle to pierce the sod rolls in both the horizontal and vertical directions. That is, the spikes extend angularly into the rolls of sod to hold the sod rolls as a unit in the sod roll pickup mechanism so that a lifting head 95 can lift the sod roll pickup mechanism and the sod rolls and place the sod rolls on a carrier. Once placed on a carrier, the sets of retractable spikes are retracted to leave the sod rolls in a neat layer of sod rolls on a pallet or the like.

Figure 11 shows the sod rolls stacked with the central axis of each level of sod rolls is in a perpendicular arrangement with the sod rolls above and below it. That is, layers 96, 97 and 98 are located on sod carrier 15a which is attached to frame 15, but the axis of the rolls of each layer of sod rolls is oriented at a right angle to the layer of sod rolls adjacent thereto. Sod carrier 15a can (if desired) include a pallet so that a stack of sod rolls can be placed on the ground for pallet pickup by another vehicle such as a forklift or the like.

Figure 12 is a schematic mechanism to indicate the axial rotation of the sod pickup mechanism 14, which includes a positioning member for both lifting, moving and rotating the sod roll pickup mechanism to enable placement of sod rolls in a stack with the axis of the sod rolls extending perpendicular to each other as shown in Figure 11.

With the present invention, the cutting and rolling of the sod occurs continuously, while the storing of sod rolls involves the intermittent operation of the sod accumulator to move sod rolls into a temporary storage position. Similarly, the transfer of sod rolls to the stack occurs intermittently since the sod rolls are only transferred to the sod stack when the accumulator is full of sod rolls.

It should be noted that this process of cutting, rolling and storing of sod is entirely automated and requires no special commands from the operator of the vehicle, but, if desired, each and every step can be manually overridden and controlled by an operator through the interface 18.

5

We claim:

1. A sod harvester for on-the-go cutting, rolling and storing of sod comprising:
a sod cutter for freeing a section of sod from a sod field;
5 a sod roller for rolling the section of sod into a sod roll;
a sod roll accumulator, said sod roll accumulator having a sod trough therein for
receiving and holding the sod roll therein;
a sod roll pickup mechanism for lifting the sod roll on the sod roll accumulator and
transferring the sod roll to a sod carrier.
10
2. The sod harvester of claim 1 wherein said sod roll accumulator comprises a set of
flexible belts held in a slack condition to form a set of said sod troughs.
3. The sod harvester of claim 1 wherein the sod roll accumulator includes a drive
15 member for advancing the sod roll accumulator to a position to receive further sod rolls.
4. The sod harvester of claim 1 wherein the sod roll pickup mechanism includes a set
of spikes for impaling and lifting the sod rolls on said sod roll accumulator.
- 20 5. The sod harvester of claim 1 wherein the sod roll pickup mechanism includes at
least two set of spikes.
6. The sod harvester of claim 1 wherein the sod roll pickup mechanism includes a
rotatable member for rotating the sod roll pickup mechanism ninety degrees to enable the
25 sod roll pickup mechanism to stack layers of sod rolls with the axis of the layers of sod
rolls extending at right angles to one another.

7. The sod harvester of claim 1 wherein said sod roller for rolling sod includes an elevating ramp for elevating the sod roll and then dropping the sod roll into said sod trough.

5 8. The sod harvester of claim 1 wherein said sod roller pickup mechanism includes at least two rows of retractable spikes for piercingly engaging through said sod roll.

9. The sod harvester of claim 8 wherein said sod roll pickup mechanism includes at least two rows of retractable spikes are in piercing engagement with said sod roll.

1 0

10. A sod harvester for on-the-go cutting, rolling and storing of sod comprising:
a sod cutter for freeing a plurality of sections of sod from a sod field;
a sod roller for rolling each of the plurality of sections of sod into a sod roll;
a sod roll accumulator, said sod roll accumulator having a set of sod troughs therein

1 5 for receiving and holding a plurality of sod rolls therein; and

a sod roll pickup mechanism for lifting the plurality of sod rolls on the sod roll accumulator and transferring the plurality of sod rolls to a sod carrier.

2 0 11. The sod harvester of claim 10 wherein said sod roll accumulator comprises a set of flexible belts held in a slack condition to form said set of sod troughs.

12. The sod harvester of claim 11 wherein the sod roll accumulator includes a drive member for intermittently advancing the flexible belts in the sod roll accumulator to a position to receive further sod rolls.

2 5

13. The sod harvester of claim 12 wherein the sod roll pickup mechanism includes a set of spikes for horizontally and vertically impaling the sod rolls to enable the sod roll pickup mechanism to lift the plurality of sod rolls from above.

5 14. The sod harvester of claim 13 wherein the sod roll pickup mechanism includes at least two sets of spikes for picking up the plurality of sod rolls on said sod roll accumulator to facilitate the pickup of sod rolls from said sod roll accumulator.

10 15. The sod harvester of claim 14 wherein the sod roll pickup mechanism includes a rotatable member for rotating the sod roll pickup mechanism ninety degrees to enable the plurality of sod rolls to be stacked with their axis in a first orientation and a further plurality of sod rolls to be stacked with their axis in a transverse orientation.

15 16. The method of on-the-go harvesting of sod comprising the steps of:
cutting a slab of sod;
rolling the cut slab of sod into a sod roll;
placing the sod roll onto a sod accumulator while waiting for at least one more roll of sod to be placed in the sod accumulator to form a plurality of sod rolls; and
removing the plurality of sod rolls from the sod accumulator and stacking the
20 plurality of sod rolls.

25 17. The method of claim 16 including the step of removing the plurality of sod rolls from the sod accumulator includes piercing the plurality of sod rolls with a plurality of spikes and then lifting the plurality of sod rolls from a position above the sod accumulator.

18. The method of claim 17 including the step of stacking the plurality of sod rolls in a first layer with the axis of the sod roll located in a first direction and stacking a further

plurality of sod rolls in an adjacent layer with the axis of the plurality of sod rolls in the adjacent layer located at right angle to the axis of sod rolls in the plurality of sod rolls in a first layer.

- 5 19. The method of claim 16 wherein the step of accumulating sod rolls comprises placing sod rolls on a set of slack belts that form catenary shaped troughs for maintaining the sod rolls therein and then periodically moving the slack belts to permit placing a further row of sod rolls on the set of slack belts.

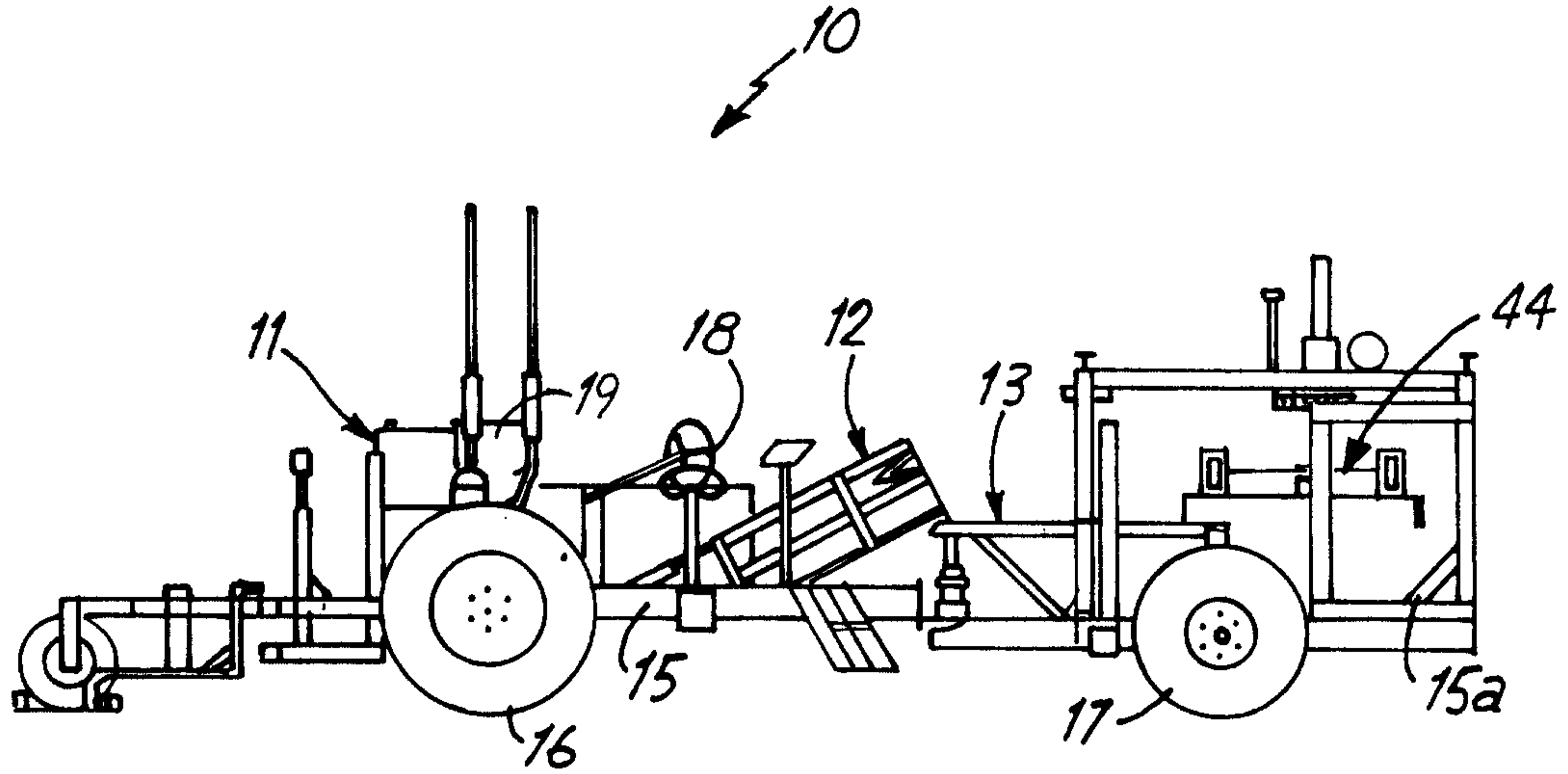

Fig. 1

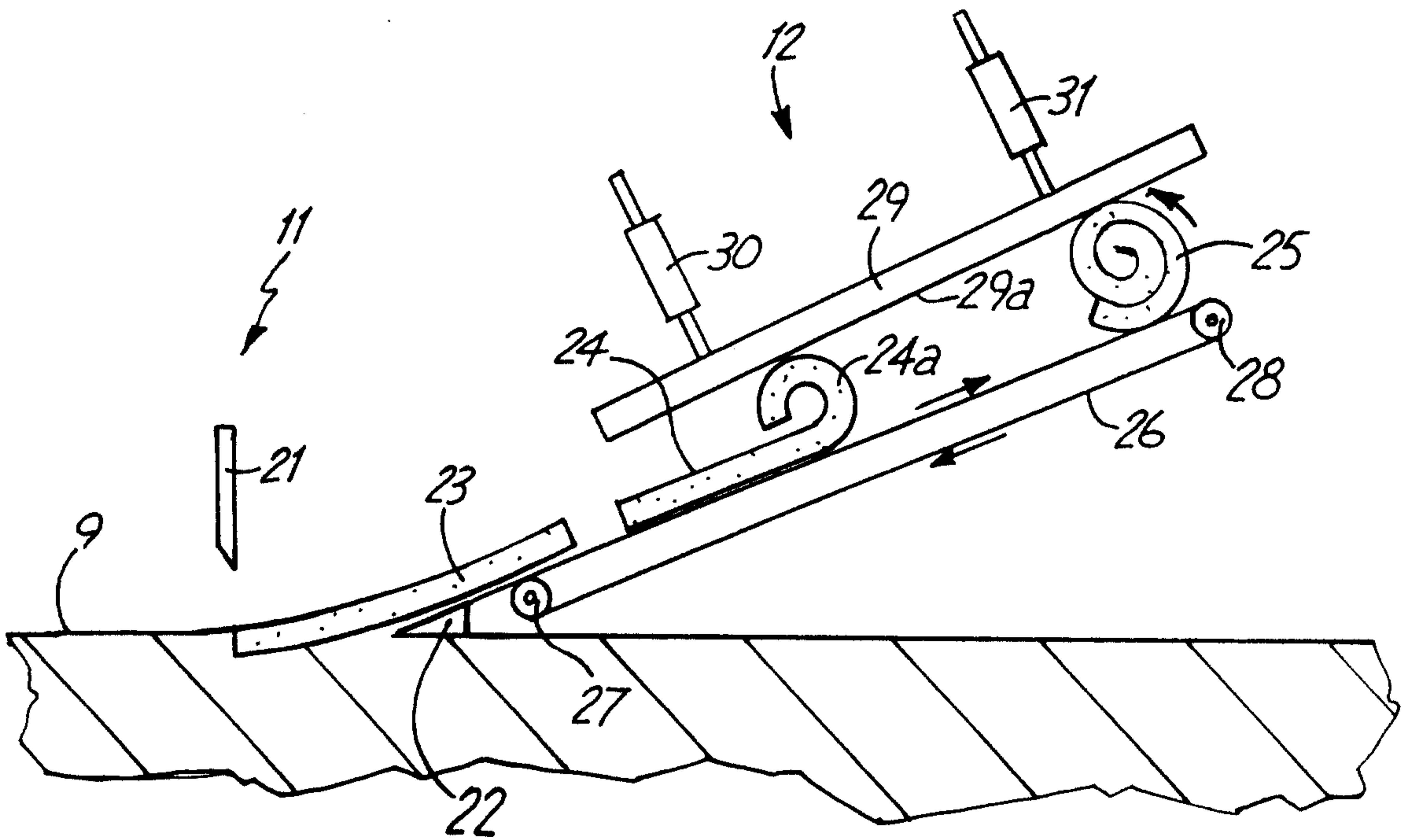

Fig. 2

INVENTOR: DONALD TVETENE ET AL
BY: ADE & COMPANY

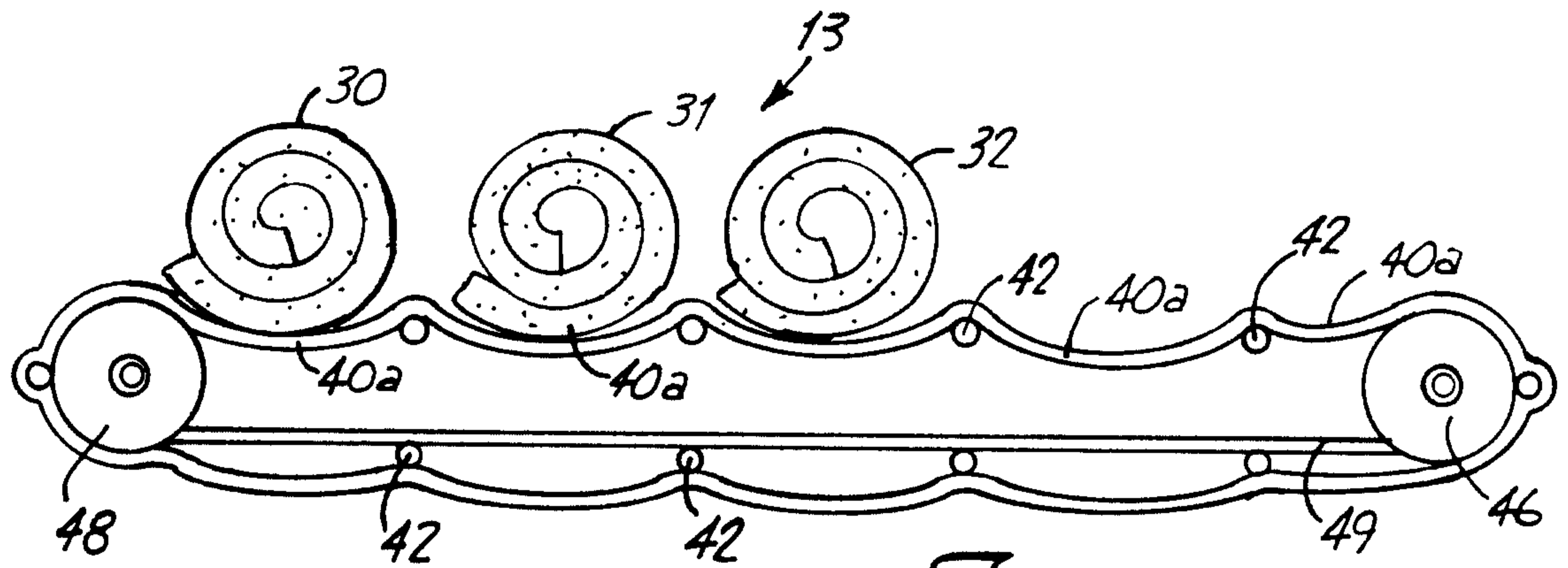

Fig. 3

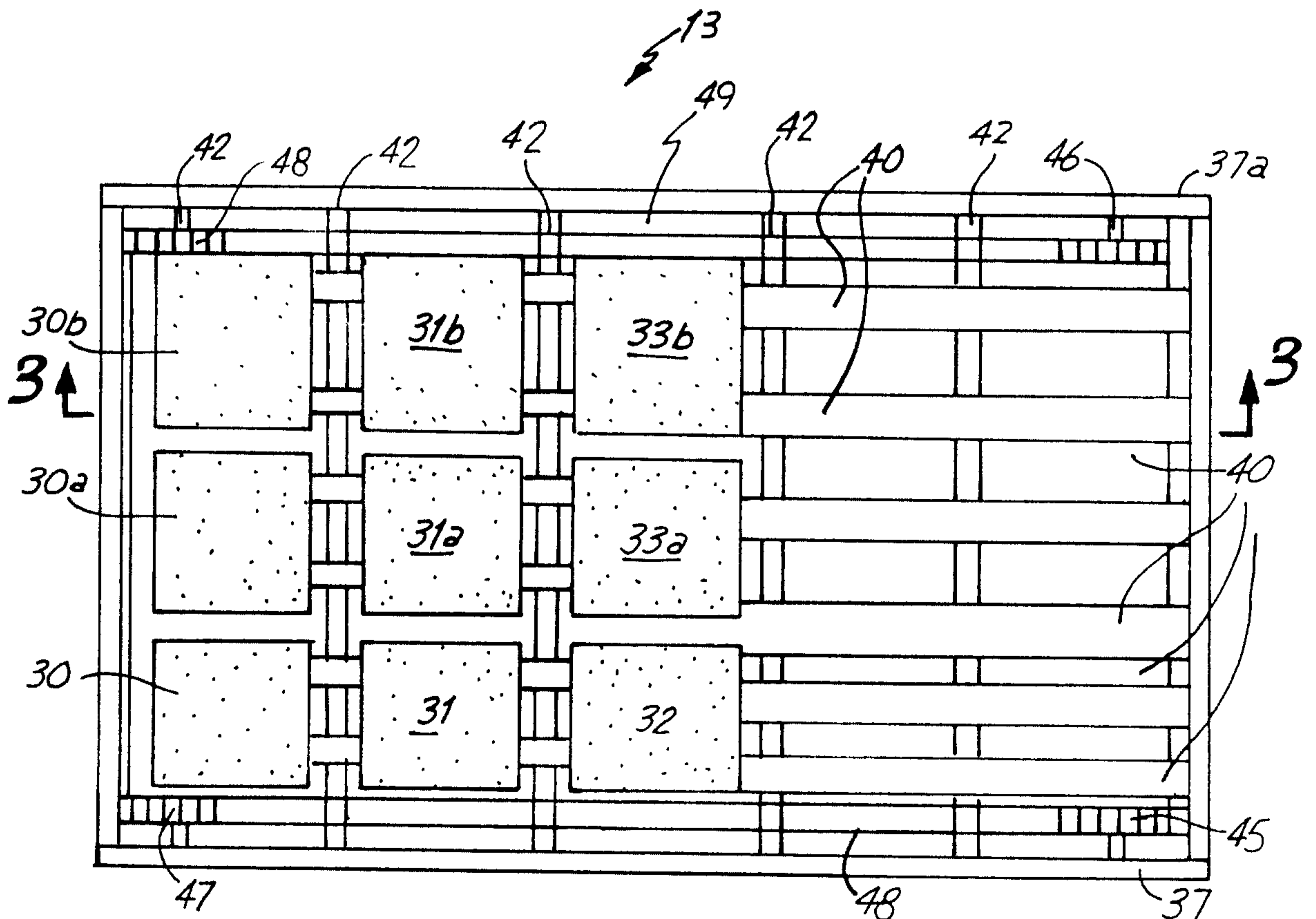

Fig. 4

INVENTOR: DONALD TVETENE ET AL
BY: ADE & COMPANY

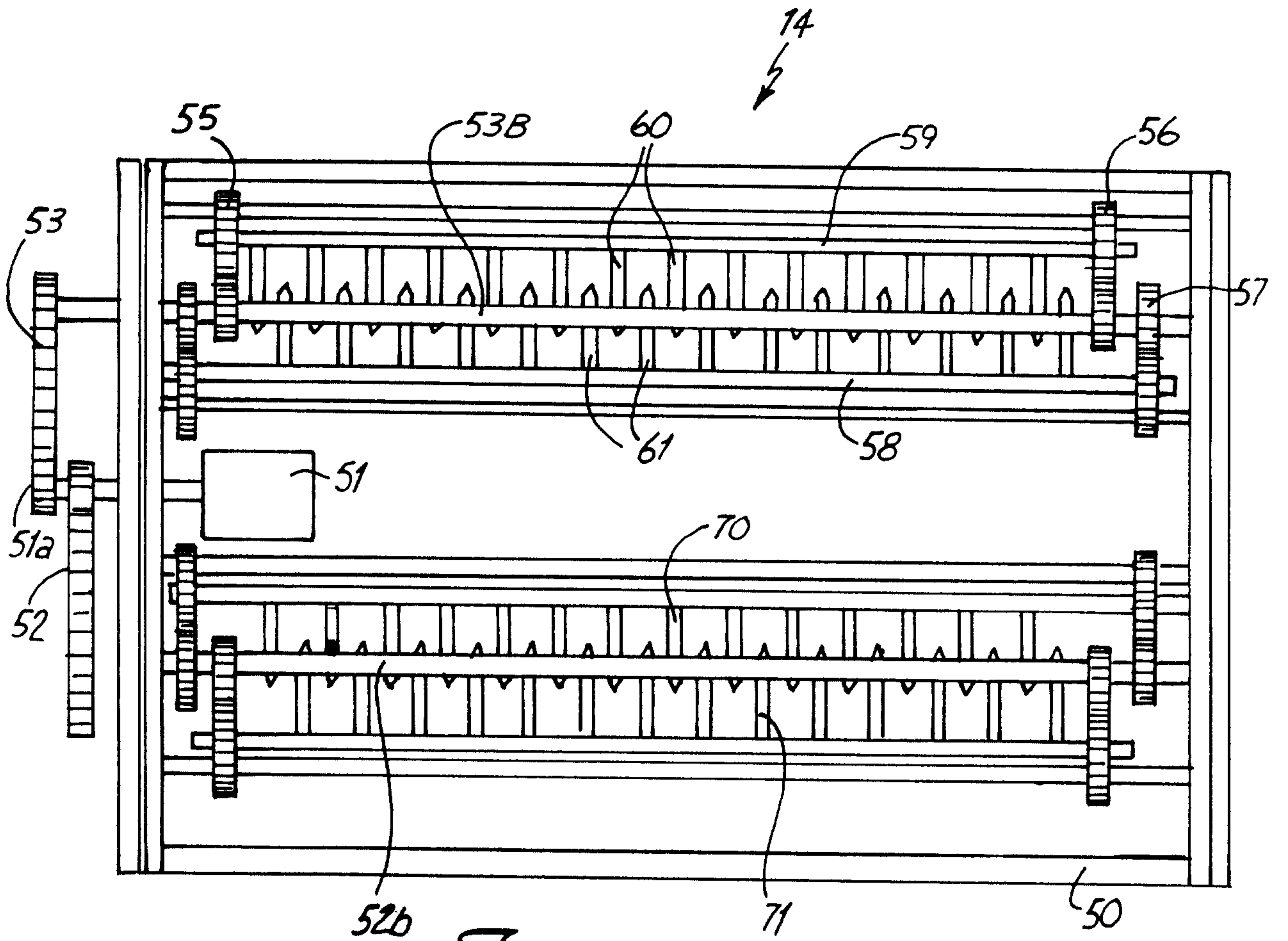

Fig. 5

INVENTOR: DONALD TVETENE ET AL
BY: ADE & COMPANY

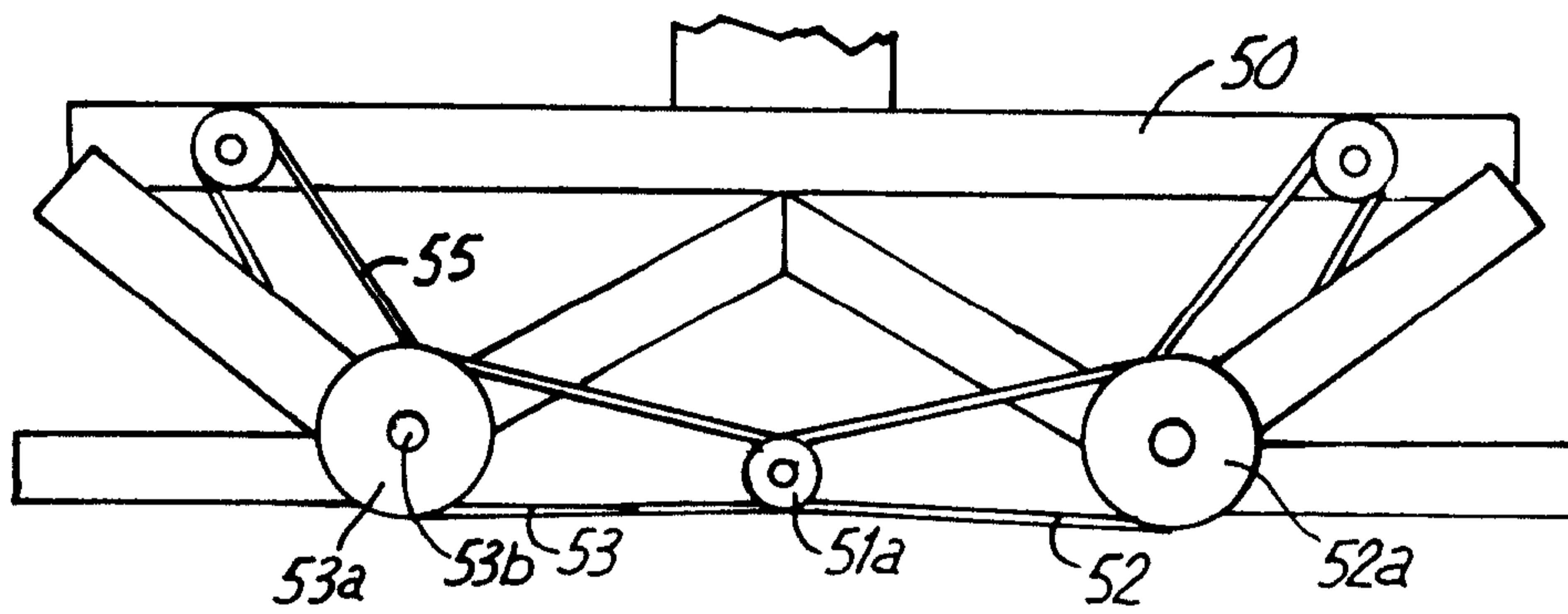

Fig. 6

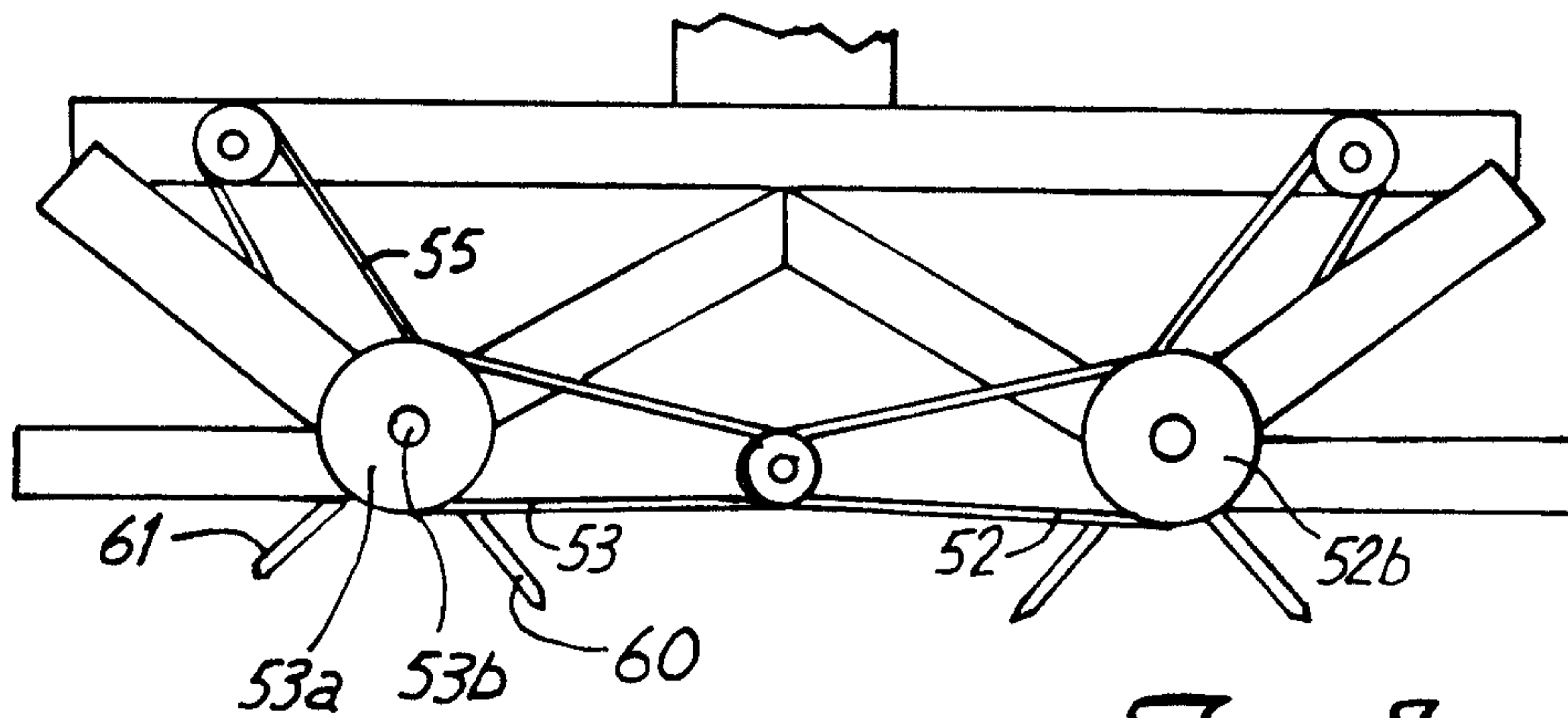

Fig. 7

INVENTOR: DONALD TVETENE ET AL
BY: ADE & COMPANY

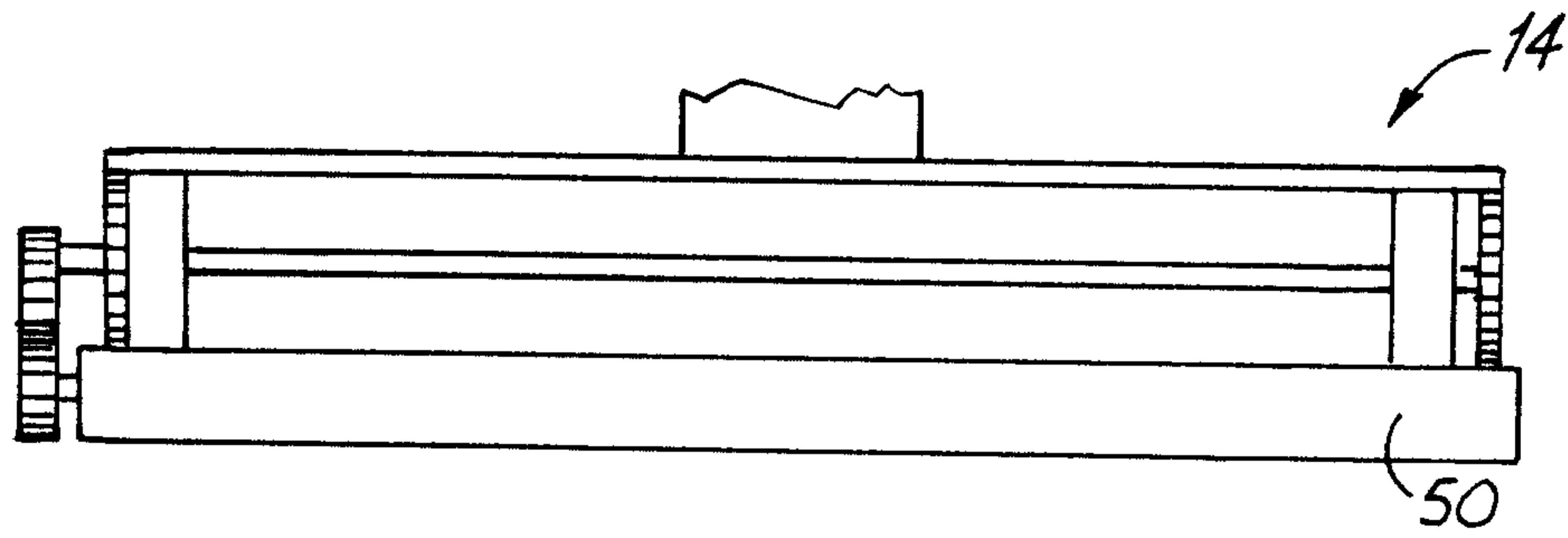

Fig. 8

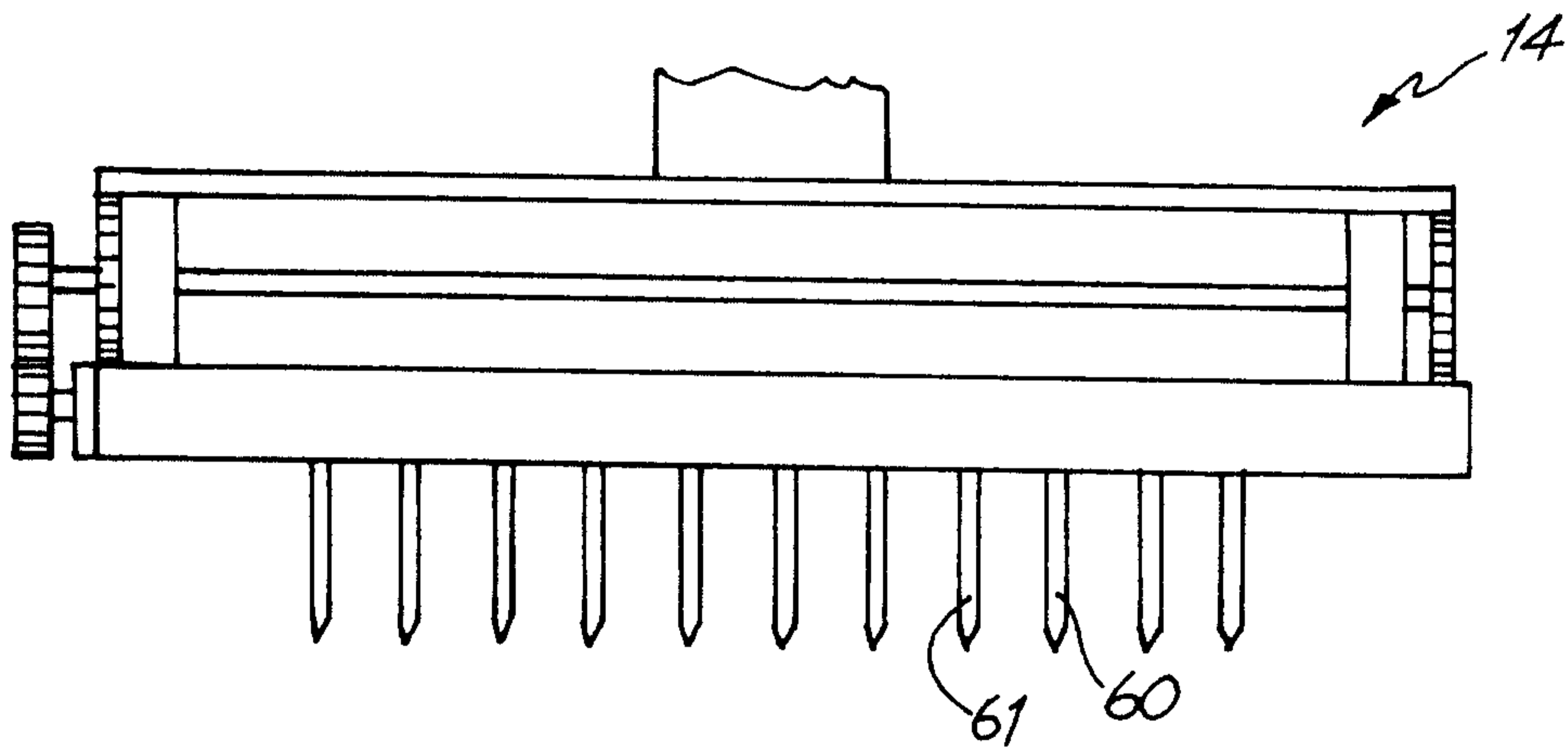

Fig. 9

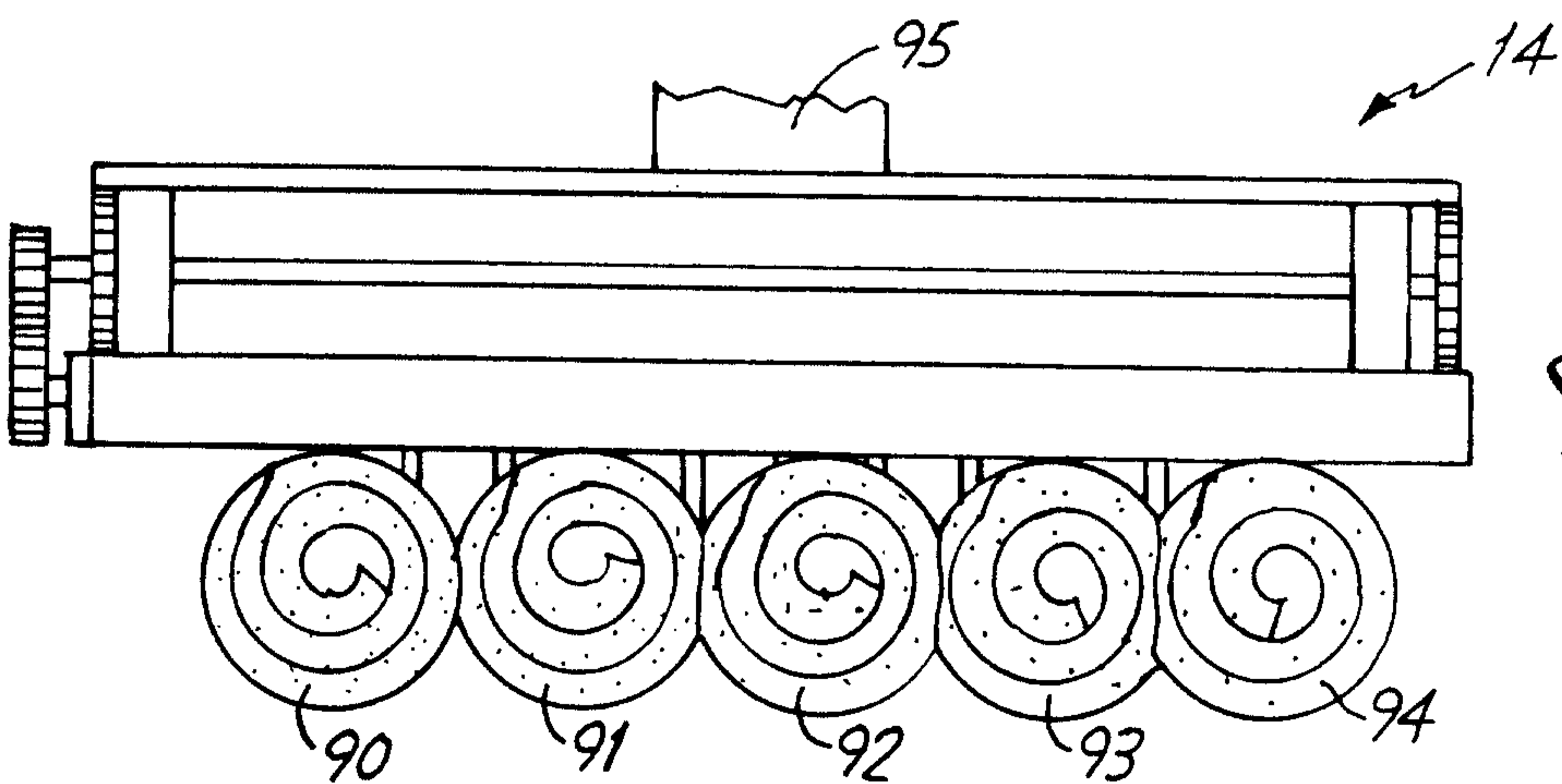
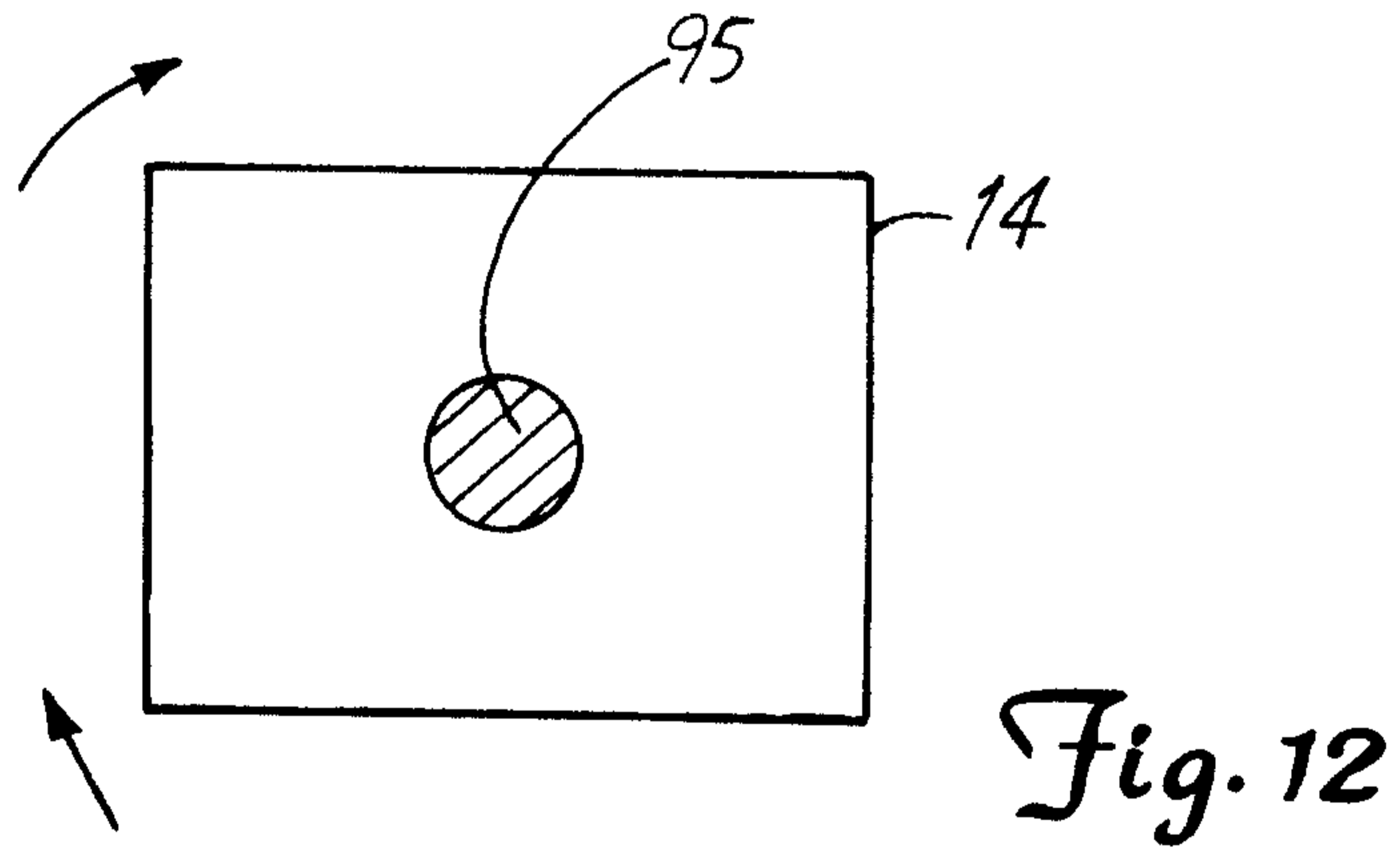
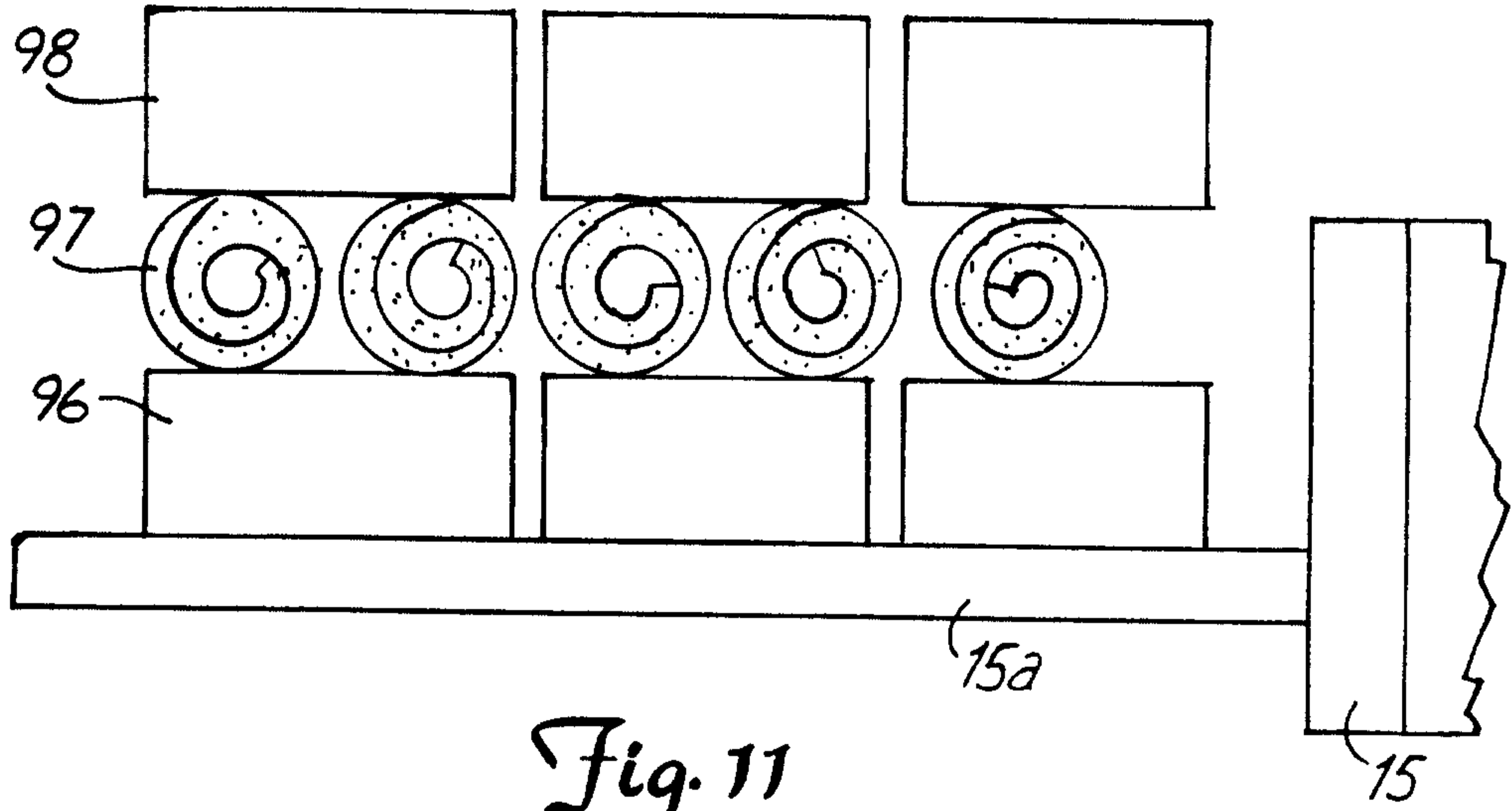

Fig. 10

INVENTOR: DONALD TVETENE ET AL
BY: ADE & COMPANY



INVENTOR: DONALD TVETENE ET AL
BY: ADE & COMPANY

