



Europäisches Patentamt
European Patent Office
Office européen des brevets



(11) **EP 1 320 307 B1**

(12) **EUROPEAN PATENT SPECIFICATION**

(45) Date of publication and mention
of the grant of the patent:

30.06.2004 Bulletin 2004/27

(21) Application number: **01975021.5**

(22) Date of filing: **06.09.2001**

(51) Int Cl.7: **A45B 3/00**

(86) International application number:
PCT/NL2001/000661

(87) International publication number:
WO 2002/024019 (28.03.2002 Gazette 2002/12)

(54) **PARASOL WITH HEATING DEVICE**

SONNENSCHIRM MIT HEIZVORRICHTUNG

PARASOL DE JARDIN POURVU D'UN CHAUFFAGE

(84) Designated Contracting States:
**AT BE CH CY DE DK ES FI FR GB GR IE IT LI LU
MC NL PT SE TR**

(30) Priority: **19.09.2000 NL 1016220**

(43) Date of publication of application:
25.06.2003 Bulletin 2003/26

(73) Proprietor: **Jacobs, Robertus Andreas Anna
Martinus
9721 EE Groningen (NL)**

(72) Inventor: **Jacobs, Robertus Andreas Anna
Martinus
9721 EE Groningen (NL)**

(74) Representative: **Dokter, Hendrik Daniel
Octrooibureau Dokter,
P.O. Box 657
7300 AR Apeldoorn (NL)**

(56) References cited:
**EP-A- 0 851 178 EP-A- 0 887 597
EP-A- 0 976 979 DE-A- 19 535 022
US-A- 5 964 233**

EP 1 320 307 B1

Note: Within nine months from the publication of the mention of the grant of the European patent, any person may give notice to the European Patent Office of opposition to the European patent granted. Notice of opposition shall be filed in a written reasoned statement. It shall not be deemed to have been filed until the opposition fee has been paid. (Art. 99(1) European Patent Convention).

Description

[0001] The invention relates to a parasol comprising a column which is provided with a base and has attached thereto a collapsible canopy, provided with a heating device mounted on the column.

[0002] Known from the American patent specification no. 5964233 is a patio umbrella with a column fixed in a dining table, provided with a radiant heater for patio heating fixed in the column. The radiant heater in the known patio parasol is provided with a chimney on its upper side which extends through an opening in the top of the canopy. The canopy is stiffened by ribs which are pivotally attached to a hood over the heater.

[0003] It is a drawback of the known patio parasol that it is necessary to discharge hot air from beneath the canopy via said opening, so that the canopy does not connect to the wall of the chimney. As a result the known patio parasol offers inadequate protection against rain falling between the canopy and the chimney wall.

[0004] Another drawback is that in collapsed state the canopy falls around the column with heater, wherein the chimney and the hood of the heater protrude freely and are exposed to weather and wind, which is of course detrimental to the lifespan of the heater.

[0005] An inherent drawback of the known patio parasol is formed by the high purchase price, since the canopy is not of the usual types which are commercially available but must be specially constructed for application in combination with a radiant heater.

[0006] It is an object of the invention to provide a patio parasol which is provided with a heating device, which parasol also offers adequate protection against rain, and the heating device of which does not necessarily remain exposed to the environment when not in use.

[0007] It is a further object to provide a patio parasol with heating device, the canopy of which is of a usual commercially available type, and which can also be manufactured at relatively low cost.

[0008] These objects are achieved, and other advantages gained, with a parasol of the type stated in the preamble, wherein according to the invention the heating device is displaceable along the column between a lowest position in state of rest, wherein the canopy is collapsed, and a highest position in operating state, wherein the canopy is opened out.

[0009] In a simple embodiment of a parasol according to the invention the heating device is manually displaceable along the column.

[0010] The parasol is preferably provided with displacing means for displacing the heating device.

[0011] In one embodiment the displacing means comprise a rotatable screw spindle which extends parallel to the column and which is mounted on its underside on the column and screwed into a spindle nut rigidly coupled to the heating device.

[0012] In another embodiment the displacing means comprise telescopic elements extending round the col-

umn.

[0013] In a very advantageous embodiment the displacing means comprise a cable which is trained over a pulley at the top of the column and which is connected on its one end to the heating device and on its other end to a winding device which is connected to the column and which can be locked for instance with a ratchet.

[0014] In an embodiment which is very easy to operate the displacing means comprise a drive motor.

[0015] The heating device in a parasol according to the invention is optionally an electric heating element or a gas or petrol or oil heater, and will therefore be provided with respectively a flexible electricity cable or a flexible gas or liquid conduit. In a favourable embodiment of a parasol according to the invention the column is therefore provided at least partially with a slot in longitudinal direction for receiving a flexible conduit in the column.

[0016] The invention provides particular advantage in an embodiment in which the base comprises a housing for receiving the heating device in the state of rest.

[0017] If the heating device is a gas heater, the base comprises in a favourable embodiment a housing for receiving a gas tank.

[0018] A parasol according to the invention is preferably provided with switching means for switching off the heating device when the parasol is collapsed, so as to prevent unsafe situations in the case of improper use.

[0019] As alternative safety measure against improper use, the parasol is provided with locking means for locking the canopy in the operating state of the heating device.

[0020] The invention will now be elucidated hereinbelow on the basis of embodiments, with reference to the drawings.

[0021] In the drawings:

Fig. 1 shows a perspective view of a first embodiment of a parasol according to the invention, Fig. 2 shows a perspective view of a second embodiment of a parasol according to the invention, Fig. 3 shows a perspective view of a third embodiment of a parasol according to the invention, Fig. 4 shows a schematic cross-section of a gas heater provided with a hood for a parasol according to the invention.

[0022] Corresponding components are designated in the drawings with the same reference numerals.

[0023] Fig. 1 shows a parasol 10 with a canopy 3 of a usual type on a column 2 which is inserted into a base 1. In the upper part of column 2 is suspended a gas heater 4 which is slidable round column 2 and which is provided with gas from a gas tank 9 from which a conduit 14 is carried along column 2 to heater 4. Heater 4 is locked with a pin 12 which protrudes through a transverse bore 13 in column 2. Since a plurality of transverse bores 13 are arranged in column 2, the height of heater

4 is adjustable. Column 2 passes through a central opening in heater 4, wherein the cross-section of this opening is larger than that of column 2, so that a substantially free space is formed between heater 4 and column 2, thus preventing column 2 from becoming overheated. Canopy 3 is manufactured from a strongly water-repellent material, for instance a 100% polyester cloth, which is protected from excessively high temperatures of heater 4 by a hood 11 over heater 4.

[0024] Fig. 2 shows a parasol 20 with a column 2 which is inserted into a base which forms the housing 8 (shown cut-away) for a gas tank 9. Heater 4 is mounted on the top side of a number of telescopic elements 5 which extend round column 2. In the rest state the telescopic elements 5 are telescoped, and heater 9 rests with its concave-shaped underside 15 in a corresponding convex-shaped upper part 16 of housing 8, and the gas conduit (not shown) between tank 9 and heater 4, which in the operating state extends through hollow column 2, is accommodated wholly in housing 8. In order to enable easy displacement of parasol 20 the housing 8 is provided with handles 17.

[0025] Fig. 3 shows a parasol 30 with a column 2 which is inserted into a base which forms the housing 8 (shown cut-away) for a gas tank 9. Heater 4 is displaceable along column 2 by means of a cable (not shown) which is trained over a pulley (not shown) at the top of column 2 and which is connected at its one end to heater 4 and at its other end to a hand winch 6 with ratchet connected to column 2. A longitudinal slot 7 in column 2 enables the gas conduit to be carried between heater 4 and gas tank 9 through the interior of the column at any height of heater 4, wherein housing 8 provides sufficient space to accommodate the gas conduit in the state of rest, wherein heater 4 rests with its convex-shaped underside 15 in the correspondingly formed concave-shaped upper part 16 of housing 8. To allow easy displacement of parasol 30 the housing 8 is provided with wheels 18.

[0026] Fig. 4 shows a part of a column 2 to which respectively a gas heater 4 and a heater hood 11 are mounted using slippers 19. Gas heater 4 takes the form of a flat cylinder with upper surface 21, a lower surface 22 provided with a gas connection 25 and a perforated outer cylinder casing 23, around which a web 24 of a nickel alloy is wrapped by way of glow body. In order to place heater 4 round the column an opening is formed in the centre, this opening being bounded by an inner cylinder casing 26 which extends above and below heater 4 and which has a diameter which is greater than that of column 2 and is provided above and below heater 4 with a reflecting surface on its outside to prevent overheating of the column by the heater. Above heater 4 a hood 11 is fixed on column 2, likewise with slippers 19 on an inner cylinder casing 27 which extends above and below hood 11 and which has a diameter which is greater than that of column 2 and is provided with a reflecting surface above and below hood 11 on its outside, where-

in cylinder casing 27 is bounded on the side directed toward heater 4 by a non-convex, in this case flat central surface 29 and a convex peripheral paraboloid 31. The flat surface 29 protects the parasol (not shown) above hood 11 and particularly the column 2 against overheating, the paraboloid 31 reflects the infrared radiation emitted by the glow covering 24 of gas heater 4 in downward direction in an annular beam, the width of which is determined by the distance between heater 4 and hood 11 and by the height of both relative to the base of the column. Hood 11 further comprises an insulating layer 28, for instance of rockwool, which is enclosed between the lower surface 29, 31 and an upper surface 32.

Claims

1. Parasol (10, 20, 30) comprising a column (2) which is provided with a base (1, 8) and has attached thereto a collapsible canopy (3), provided with a heating device (4) mounted on the column (2), **characterized in that** the heating device (4) is displaceable along the column (2) between a lowest position in state of rest, wherein the canopy (3) is collapsed, and a highest position in operating state, wherein the canopy (3) is opened out.
2. Parasol (10, 20, 30) as claimed in claim 1, **characterized in that** it is provided with displacing means (5, 6) for displacing the heating device (4).
3. Parasol as claimed in claim 2, **characterized in that** the displacing means comprise a rotatable screw spindle which extends parallel to the column and which is mounted on its underside on the column and screwed into a spindle nut rigidly coupled to the heating device.
4. Parasol (20) as claimed in claim 2, **characterized in that** the displacing means comprise telescopic elements (5) extending round the column (2).
5. Parasol (30) as claimed in claim 2, **characterized in that** the displacing means comprise a cable which is trained over a pulley at the top of the column (2) and which is connected on its one end to the heating device (4) and on its other end to a winding device (6) connected to the column (2).
6. Parasol as claimed in any of the claims 3-5, **characterized in that** the displacing means comprise a drive motor.
7. Parasol (30) as claimed in any of the foregoing claims, **characterized in that** the column (2) is provided at least partially with a slot (7) in longitudinal direction for receiving a flexible conduit in the column (2).

8. Parasol (20, 30) as claimed in any of the foregoing claims, **characterized in that** the base comprises a housing (8) for receiving the heating device (4) in the state of rest.
9. Parasol (10, 20, 30) as claimed in any of the foregoing claims, **characterized in that** the heating device is a gas heater (4).
10. Parasol (10, 20, 30) as claimed in claim 9, **characterized in that** the gas heater (4) comprises a central opening for receiving the column (2), wherein the cross-section of the opening is larger than that of the column (2) so as to form a substantially free space between the gas heater (4) and the column (2).
11. Parasol (20, 30) as claimed in either of the claims 9-10, **characterized in that** the base comprises a housing (8) for receiving a gas tank (9).
12. Parasol as claimed in any of the claims 1-11, **characterized in that** it is provided with a reflector (11) between the canopy (3) and the heating device (4).
13. Parasol as claimed in claim 12, **characterized in that** the reflector (11) is provided with a central opening for receiving the column (2), which opening is bounded on the side directed toward the heating device (4) by a non-convex central surface (29) and a convex peripheral paraboloid (31).
14. Parasol as claimed in any of the claims 1-11, **characterized in that** it is provided with switching means for switching off the heating device when the parasol is collapsed.
15. Parasol as claimed in any of the claims 1-11, **characterized in that** it is provided with locking means for locking the canopy in the operating state of the heating device.
- (5, 6) zum Verstellen der Heizvorrichtung (4) versehen ist.
3. Sonnenschirm nach Anspruch 2, **dadurch gekennzeichnet, dass** die Verstellmittel eine drehbare Schraubenspindel umfassen, die sich parallel zu dem Mast erstreckt und die an ihrer Unterseite an dem Mast befestigt und in eine starr mit der Heizvorrichtung gekoppelten Spindelmutter geschraubt ist.
4. Sonnenschirm (20) nach Anspruch 2, **dadurch gekennzeichnet, dass** die Verstellmittel sich um den Mast (2) erstreckende Teleskopelemente (5) umfassen.
5. Sonnenschirm (30) nach Anspruch 2, **dadurch gekennzeichnet, dass** die Verstellmittel ein Seil umfassen, das über eine Seilscheibe an der Oberseite des Mastes (2) geführt wird und das an seinem einen Ende mit der Heizvorrichtung (4) und an seinem anderen Ende mit einer mit dem Mast (2) verbundenen Aufwickelvorrichtung (6) verbunden ist.
6. Sonnenschirm nach einem der Ansprüche 3-5, **dadurch gekennzeichnet, dass** die Verstellmittel einen Antriebsmotor umfassen.
7. Sonnenschirm (30) nach einem der obigen Ansprüche, **dadurch gekennzeichnet, dass** der Mast (2) zumindest teilweise mit einem Spalt (7) in Längsrichtung zur Aufnahme einer flexiblen Leitung in den Mast (2) versehen ist.
8. Sonnenschirm (20, 30) nach einem der obigen Ansprüche, **dadurch gekennzeichnet, dass** der Fuß ein Gehäuse (8) zur Aufnahme der Heizvorrichtung (4) in der Ruhelage umfasst.
9. Sonnenschirm (10, 20, 30) nach einem der obigen Ansprüche, **dadurch gekennzeichnet, dass** die Heizvorrichtung ein Gasbrenner (4) ist.

Patentansprüche

1. Sonnenschirm (10, 20, 30), der einen mit einem Fuß (1, 8) versehenen Mast (2) und ein daran befestigtes faltbares Schirmdach (3) umfasst, und der mit einer an dem Mast (2) befestigten Heizvorrichtung (4) versehen ist, **dadurch gekennzeichnet, dass** die Heizvorrichtung (4) entlang dem Mast (2) zwischen einem niedrigsten Stand in Ruhelage, wobei das Schirmdach (3) zusammengeklappt ist, und einem höchsten Stand in Betriebszustand, wobei das Schirmdach (3) geöffnet ist, verstellbar ist.
2. Sonnenschirm (10, 20, 30) nach Anspruch 1, **dadurch gekennzeichnet, dass** er mit Verstellmitteln
10. Sonnenschirm (10, 20, 30) nach Anspruch 9, **dadurch gekennzeichnet, dass** der Gasbrenner (4) eine zentrale Öffnung zur Aufnahme des Mastes (2) umfasst, wobei der Querschnitt der Öffnung größer als der des Mastes (2) ist, um so einen im Wesentlichen freien Raum zwischen dem Gasbrenner (4) und dem Mast (2) zu bilden.
11. Sonnenschirm (20, 30) nach einem der Ansprüche 9-10, **dadurch gekennzeichnet, dass** der Fuß ein Gehäuse (8) zur Aufnahme des Gastanks (9) umfasst.
12. Sonnenschirm nach einem der Ansprüche 1-11, **dadurch gekennzeichnet, dass** er mit einem Reflek-

tor (11) zwischen dem Schirmdach (3) und der Heizvorrichtung (4) versehen ist.

13. Sonnenschirm nach Anspruch 12, **dadurch gekennzeichnet, dass** der Reflektor (11) mit einer zentralen Öffnung zur Aufnahme des Mastes (2) versehen ist, und diese Öffnung wird an der zur Heizvorrichtung (4) gekehrten Seite von einer nicht-konvexen zentralen Fläche (29) und einem konvexen peripheren Paraboloid (31) begrenzt. 5 10
14. Sonnenschirm nach einem der Ansprüche 1-11, **dadurch gekennzeichnet, dass** er mit Schaltmitteln zum Ausschalten der Heizvorrichtung beim Zusammenfallen des Sonnenschirms versehen ist. 15
15. Sonnenschirm nach einem der Ansprüche 1-11, **dadurch gekennzeichnet, dass** er mit Feststellmitteln zum Feststellen des Schirmdachs im Betriebszustand der Heizvorrichtung versehen ist. 20

Revendications

1. Parasol (10, 20, 30) comprenant une colonne (2) qui est pourvue d'une base (1, 8) et à laquelle un auvent repliable (3) est attaché, équipé d'un dispositif de chauffage (4) monté sur la colonne (2), **caractérisé en ce que** le dispositif de chauffage (4) peut être déplacé le long de la colonne (2) entre une position la plus basse à l'état de repos, dans laquelle l'auvent (3) est replié, et une position la plus haute à l'état opérationnel, dans laquelle l'auvent (3) est déployé. 25 30
2. Parasol (10, 20, 30) suivant la revendication 1, **caractérisé en ce que** celui-ci est pourvu d'un moyen de déplacement (5, 6) pour déplacer le dispositif de chauffage (4). 35
3. Parasol suivant la revendication 2, **caractérisé en ce que** le moyen de déplacement comprend une broche à vis rotative qui s'étend parallèlement à la colonne et qui est montée sur sa face inférieure sur la colonne et qui est vissée dans un écrou de broche couplé d'une façon rigide au dispositif de chauffage. 40 45
4. Parasol (20) suivant la revendication 2, **caractérisé en ce que** le moyen de déplacement comprend des éléments télescopiques (5) qui s'étendent autour de la colonne (2). 50
5. Parasol (30) suivant la revendication 2, **caractérisé en ce que** le moyen de déplacement comprend un câble qui est entraîné sur une poulie au sommet de la colonne (2) et qui est connecté à sa première extrémité au dispositif de chauffage (4), et à son autre extrémité à un dispositif d'enroulement (6) connecté

à la colonne (2).

6. Parasol suivant l'une quelconque des revendications 3 à 5, **caractérisé en ce que** le moyen de déplacement comprend un moteur de commande.
7. Parasol (30) suivant l'une quelconque des revendications précédentes, **caractérisé en ce que** la colonne (2) est pourvue au moins partiellement d'une fente (7) dans la direction longitudinale destinée à accueillir une conduite flexible dans la colonne (2).
8. Parasol (20, 30) suivant l'une quelconque des revendications précédentes, **caractérisé en ce que** la base comprend une enceinte (8) destinée à recevoir le dispositif de chauffage (4) à l'état de repos.
9. Parasol (10, 20, 30) suivant l'une quelconque des revendications précédentes, **caractérisé en ce que** le dispositif de chauffage est un radiateur au gaz (4).
10. Parasol (10, 20, 30) suivant la revendication 9, **caractérisé en ce que** le radiateur au gaz (4) comporte une ouverture centrale destinée à accueillir la colonne (2), dans lequel la section transversale de l'ouverture est plus grande que celle de la colonne (2) de manière à former un espace substantiellement libre entre le radiateur au gaz (4) et la colonne (2).
11. Parasol suivant l'une quelconque des revendications 9 et 10, **caractérisé en ce que** la base comprend une enceinte (8) destinée à loger un réservoir de gaz (9).
12. Parasol suivant l'une quelconque des revendications 1 à 11, **caractérisé en ce que** celui-ci est pourvu d'un réflecteur (11) entre l'auvent (3) et le dispositif de chauffage (4).
13. Parasol suivant la revendication 12, **caractérisé en ce que** le réflecteur (11) est pourvu d'une ouverture centrale destinée à accueillir la colonne (2), ladite ouverture étant délimitée au niveau de la face orientée en direction du dispositif de chauffage (4) par une surface centrale non convexe (29) et par un paraboloïde périphérique convexe (31).
14. Parasol suivant l'une quelconque des revendications 1 à 11, **caractérisé en ce que** celui-ci est pourvu d'un moyen de commutation pour éteindre le dispositif de chauffage lorsque le parasol est replié.
15. Parasol suivant l'une quelconque des revendications 1 à 11, **caractérisé en ce que** celui-ci est pourvu d'un moyen de verrouillage pour verrouiller

l'auvent lorsque le dispositif de chauffage fonctionne.

5

10

15

20

25

30

35

40

45

50

55

6

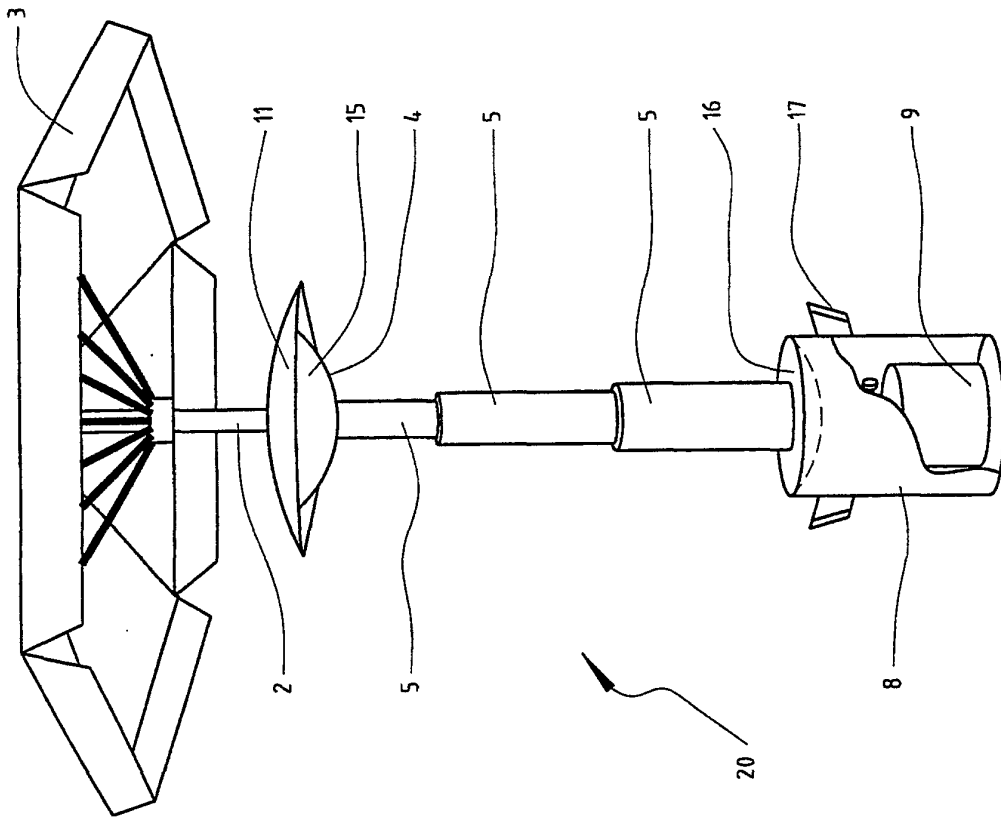

Fig. 2

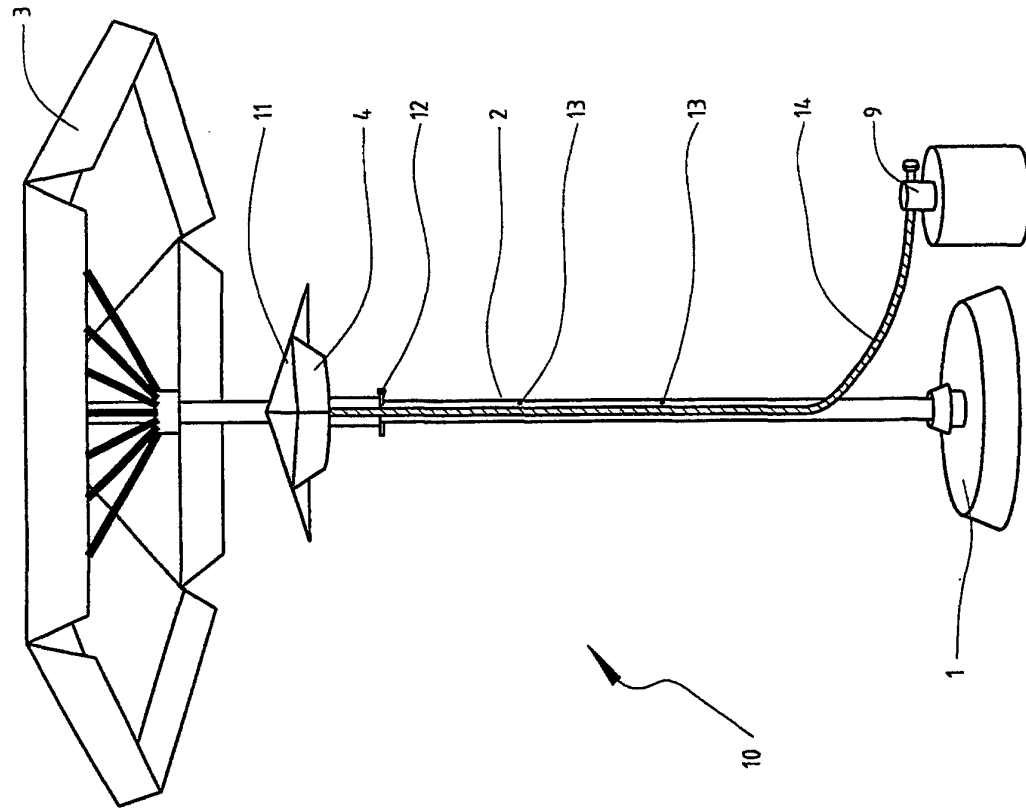

Fig. 1

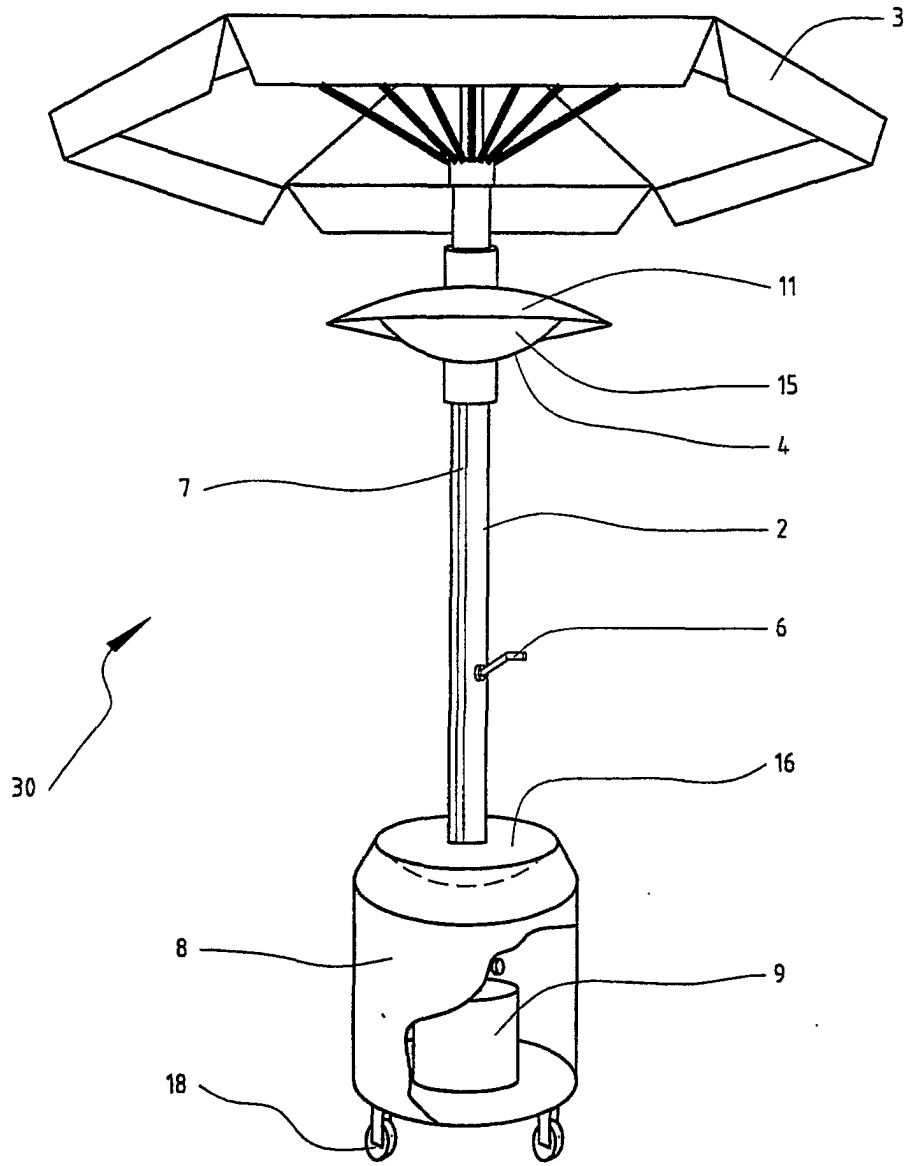

Fig. 3

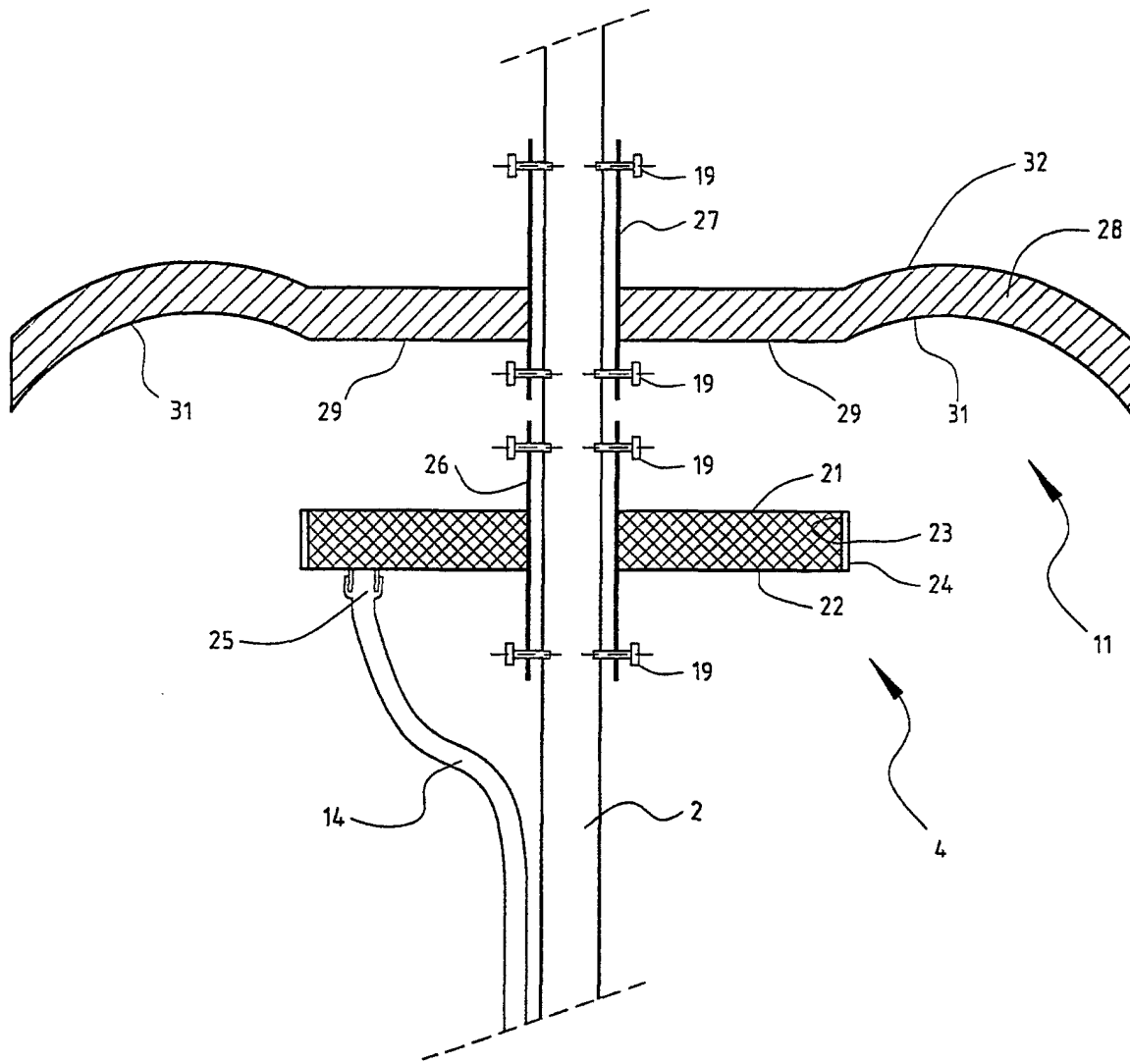

Fig. 4