

C. D. KANOUSE.  
 FLUSH PEDAL DOOR FOR PLAYER PIANOS.  
 APPLICATION FILED AUG. 24, 1910.

997,197.

Patented July 4, 1911.

2 SHEETS—SHEET 1.

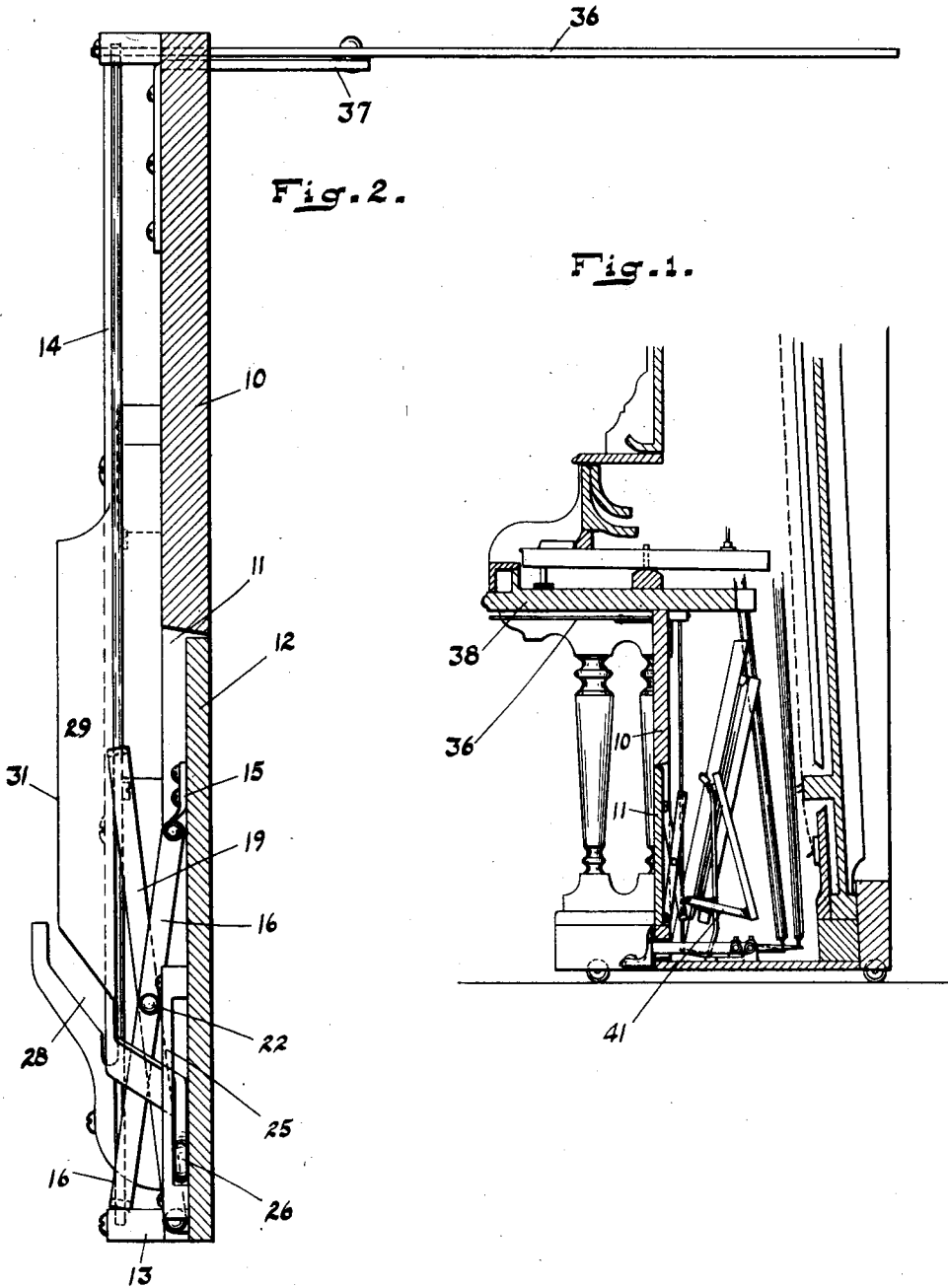

Witnesses  
 Walter Troemel,  
 Thomas W. McMeans

Inventor  
 Clark D. Kanouse.  
 By *Bradford & Hood,*  
 Attorneys.

C. D. KANOUSE.  
 FLUSH PEDAL DOOR FOR PLAYER PIANOS.  
 APPLICATION FILED AUG. 24, 1910.

997,197.

Patented July 4, 1911.

2 SHEETS-SHEET 2.

Fig. 4.

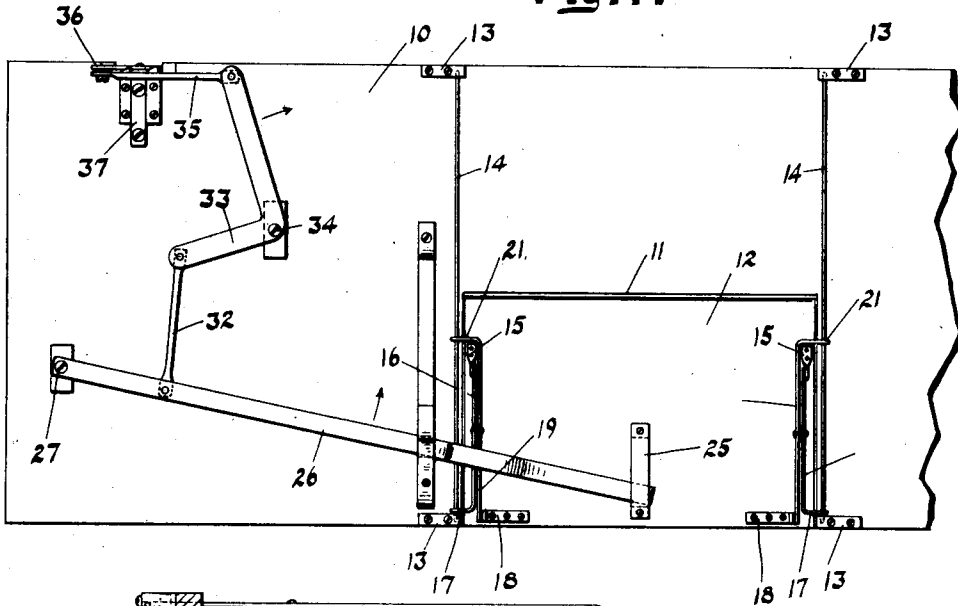
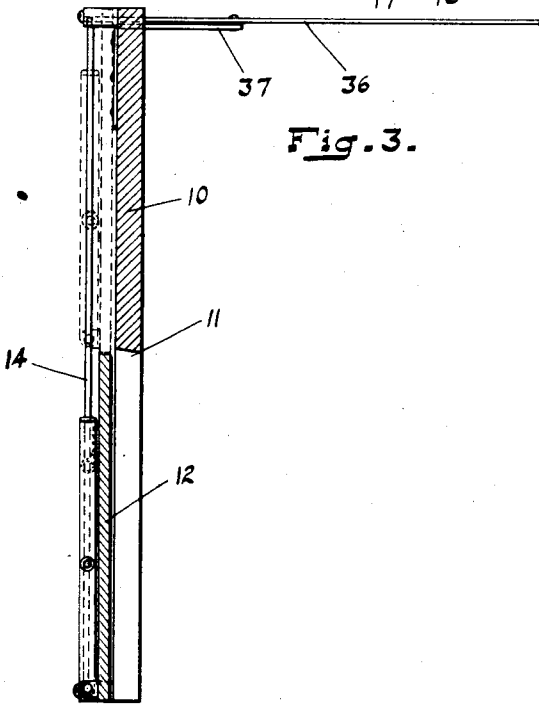

Fig. 3.



Witnesses  
 Walter Troemel,  
 Thomas H. McMeans

Inventor  
 Clark D. Kanouse.

By *Bradford & Hood,*  
 Attorneys.

# UNITED STATES PATENT OFFICE.

CLARK D. KANOUSE, OF RICHMOND, INDIANA, ASSIGNOR TO STARR PIANO COMPANY,  
OF RICHMOND, INDIANA, A CORPORATION OF INDIANA.

FLUSH PEDAL-DOOR FOR PLAYER-PIANOS.

997,197.

Specification of Letters Patent.

Patented July 4, 1911.

Application filed August 24, 1910. Serial No. 578,777.

*To all whom it may concern:*

Be it known that I, CLARK D. KANOUSE, a citizen of the United States, residing at Richmond, in the county of Wayne and State of Indiana, have invented a new and useful Flush Pedal-Door for Player-Pianos, of which the following is a specification.

The object of my invention is to produce a flush closing panel for the pedal opening of player pianos, the construction being such that the closing door or panel may be readily operated by means of an easily accessible lever.

The accompanying drawings illustrate my invention.

Figure 1 is a fragmentary vertical section of a player piano equipped with my invention; Fig. 2 an enlarged vertical section of the removable front board equipped with my improved closing device; Fig. 3 a similar view on a smaller scale showing the door retracted into position to be elevated away from the pedal opening, and Fig. 4 a fragmentary inner elevation.

In the drawings, 10 indicates a usual and ordinary front board of a piano, said board being of any desired form and being readily removable as a whole in any ordinary way. The board 10 is provided at the middle of its lower edge with a pedal opening 11 which is to be closed by a panel or plate 12 which, in the form shown, is formed so that its exposed face will, when in position, come flush with the exposed face of the board 10, as clearly shown in Figs. 1 and 2. Secured in suitable brackets 13 on the inner face of board 10 are two parallel vertical guide rods 14, 14 which lie alongside the vertical sides of opening 11. Secured to the inner face of plate 12 near each upper corner is a bracket 15 to which is pivoted the upper end of a link 16 the lower end of which is turned outwardly to form a foot 17 which is perforated so as to loosely receive and slide upon bar 14. Secured to the inner face of plate 12 near each lower corner is a bracket 18 to which is pivoted the lower end of a link 19 the upper end of which is turned outwardly to form a foot 21 which is perforated to loosely receive and slide upon rod 14. The two links 16 and 19 are pivotally connected together by a medial pivot 22. In its lower position foot 17 of each link 16 rests upon the adjacent bracket 13 and the connection between

the lower end of link 19 and its bracket 18 is capable of a slight longitudinal yield. This slight yield between each link 19 and its bracket 18, longitudinally of the link 19, is necessary in order to permit the slight springing of the toggle 16—19, which is necessary in order to permit the panel to move substantially at right angles out of the plane of the front board.

Secured to the inner face of plate 12 is a yoke 25 which forms a vertical guide and limit for the end of a lever 26 which is pivoted at 27 to the inner face of board 10. Lever 26 is adapted to enter and play within a cam slot 28 formed in a board 29 secured to the inner face of board 10, the slot 28 forming a continuation for a straight cam surface or edge 31 formed by the free edge of board 29. Connected to link 26 is one end of a link 32 the opposite end being connected to one arm of a bell-crank lever 33 pivoted at 34 upon the inner face of board 10. Connected to the opposite arm of bell-crank lever 33 is a link 35 which, in turn, is pivoted to the inner end of a lever 36 pivoted to a bracket 37 secured to the upper edge of board 10, the lever 36 being extended horizontally to a point near the front edge of a key bed 38.

With the parts in position as shown in Figs. 1, 2 and 4, the operation is as follows: Lever 36 is swung so as to drive levers 32, 33 and 35 in the directions indicated by the arrows in Fig. 4. This lifts lever 26 and its first movement causes it to slide vertically freely in yoke 25 but to be itself displaced inwardly by cam slot 28 so as to draw plate 12 inwardly to the position shown in full lines in Fig. 3. Continued upward movement of lever 26 will then raise the plate 12 vertically to the position shown in dotted lines in Fig. 3, thus leaving the opening 11 entirely unobstructed so that the pedal mechanisms 41 may be projected therethrough.

I claim—

1. The combination, with a front board having a pedal opening therethrough, of a panel for closing said opening, supports for said panel for initial movement thereof along a line substantially at right angles to the plane of the board, and also for subsequent movement thereof bodily at an angle to the first movement, and a single operating member for engaging and shifting

said panel successively in both directions, the said several parts being mounted upon and bodily removable with the front board.

2. The combination, with a front board  
5 having a pedal opening therethrough, of a panel for closing said opening, supports for said panel for initial movement thereof along a line substantially at right angles to the plane of the board, and also for subsequent movement thereof bodily at an angle to the first movement, and a single operating member for engaging and shifting said panel successively in both directions.

3. The combination, with a front board  
15 having a pedal opening therethrough, of a panel in the plane of the front board for closing said opening, a vertical guide arranged adjacent said opening to the rear thereof, a pair of pivotally-connected levers connected to and supporting said panel and  
20 slidably mounted on said guide, an operating member engaging said panel, and a controlling member for said operating member whereby the initial movement of said operating member will cause movement of the panel to a position outside of the plane of the front board and subsequent movement of the operating member will shift the panel longitudinally of the guide.

4. The combination, with a front board  
30 having a pedal opening therethrough, of a pair of guide rods mounted upon the inner face of the front board adjacent the pedal opening, a panel for closing said pedal opening, two pairs of pivotally-connected levers mounted upon the inner face of said panel and each pair slidably mounted upon a  
35 guide rod, an operating member engaging said panel mounted upon the inner face of the front board, a cam mounted upon the inner face of the front board and arranged to engage the operating member to move the same laterally during transverse movement, and a horizontally extending lever carried  
40 by the front board and extending forwardly and connected with the operating member.

5. The combination, with a front board having a pedal opening therethrough, of a

pair of guide rods mounted upon the inner  
50 face of the pedal board adjacent the front opening, a panel for closing said pedal opening, two pairs of pivotally-connected levers mounted upon the inner face of said panel and each pair slidably mounted upon a  
55 guide rod, an operating member engaging said panel, a cam arranged to engage the operating member to move the same laterally during transverse movement, and a horizontally extending lever extending forwardly and connected with the operating  
60 member.

6. The combination, with a pedal board having a front opening therethrough, of a pair of guide rods mounted upon the inner  
65 face of the front board adjacent the pedal opening, a panel for closing said pedal opening, two pairs of pivotally-connected levers mounted upon the inner face of said panel and each pair slidably mounted upon the  
70 guide rod, an operating member engaging said panel mounted upon the inner face of the front board, and a cam mounted upon the inner face of the front board and arranged to engage the operating member to move the same laterally during transverse  
75 movement.

7. The combination, with a pedal board having a front opening therethrough, of a pair of guide rods mounted upon the inner  
80 face of the pedal board adjacent the front opening, a panel for closing said pedal opening, two pairs of pivotally-connected levers mounted upon the inner face of said panel and each pair slidably mounted upon the  
85 guide rod, an operating member engaging said panel and a cam arranged to engage the operating member to move the same laterally during transverse movement.

In witness whereof, I, CLARK D. KANOUSE have hereunto set my hand and seal at  
90 Richmond, Indiana, this 13th day of August, A. D. one thousand nine hundred and ten.

CLARK D. KANOUSE. [L. s.]

Witnesses:

FRANCIS W. DRAPER,  
ARNOLD E. PFEIFFER.