



- (51) **International Patent Classification:**  
H04W 74/08 (2009.01) H04L 27/26 (2006.01)
- (21) **International Application Number:**  
PCT/EP2014/062383
- (22) **International Filing Date:**  
13 June 2014 (13.06.2014)
- (25) **Filing Language:** English
- (26) **Publication Language:** English
- (30) **Priority Data:**  
61/969,912 25 March 2014 (25.03.2014) US
- (71) **Applicant:** TELEFONAKTIEBOLAGET L M ERICSSON (PUBL) [SE/SE]; S-164 83 Stockholm (SE).
- (72) **Inventors:** SAHLIN, Henrik; Kalkstensvägen 1, S-43541 Mölnlycke (SE). FRENNE, Mattias; Arkeologvägen 20, S-75443 Uppsala (SE). ANDERSSON, Håkan; Gallstrandsvägen 24, S-58599 Linköping (SE). FURUSKOG, Johan; Igeldammsgatan 28, S-11249 Stockholm (SE). NAUCLÉR, Peter; Högäsvägen 115, S-74141 Knivsta (SE).
- (74) **Agent:** VEJGAARD, Christian; Ericsson, Patent Unit GL, Lindholmospiren 11, S-417 56 Göteborg (SE).

(81) **Designated States** (unless otherwise indicated, for every kind of national protection available): AE, AG, AL, AM, AO, AT, AU, AZ, BA, BB, BG, BH, BN, BR, BW, BY, BZ, CA, CH, CL, CN, CO, CR, CU, CZ, DE, DK, DM, DO, DZ, EC, EE, EG, ES, FI, GB, GD, GE, GH, GM, GT, HN, HR, HU, ID, IL, IN, IR, IS, JP, KE, KG, KN, KP, KR, KZ, LA, LC, LK, LR, LS, LT, LU, LY, MA, MD, ME, MG, MK, MN, MW, MX, MY, MZ, NA, NG, NI, NO, NZ, OM, PA, PE, PG, PH, PL, PT, QA, RO, RS, RU, RW, SA, SC, SD, SE, SG, SK, SL, SM, ST, SV, SY, TH, TJ, TM, TN, TR, TT, TZ, UA, UG, US, UZ, VC, VN, ZA, ZM, ZW.

(84) **Designated States** (unless otherwise indicated, for every kind of regional protection available): ARIPO (BW, GH, GM, KE, LR, LS, MW, MZ, NA, RW, SD, SL, SZ, TZ, UG, ZM, ZW), Eurasian (AM, AZ, BY, KG, KZ, RU, TJ, TM), European (AL, AT, BE, BG, CH, CY, CZ, DE, DK, EE, ES, FI, FR, GB, GR, HR, HU, IE, IS, IT, LT, LU, LV, MC, MK, MT, NL, NO, PL, PT, RO, RS, SE, SI, SK, SM, TR), OAPI (BF, BJ, CF, CG, CI, CM, GA, GN, GQ, GW, KM, ML, MR, NE, SN, TD, TG).

**Published:** — with international search report (Art. 21(3))

(54) **Title:** TRANSMISSION AND RECEPTION OF A RANDOM ACCESS PREAMBLE SIGNAL

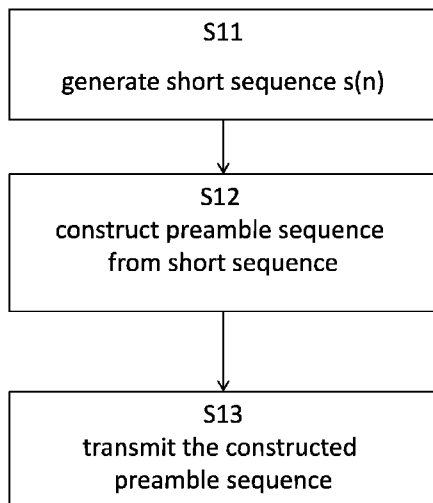

(57) **Abstract:** A method performed in a preamble transmitter for transmitting a preamble sequence, the method comprising the steps of generating S11 a short sequence  $s(n)$ , the short sequence having the same time duration as an OFDM symbol used for carrying data traffic in a radio access network of the preamble transmitter, constructing S12 a preamble sequence by concatenating a plurality of said short sequences in time, and transmitting S13 the constructed preamble sequence as a radio signal to a preamble receiver. transmission and reception of a random access preamble signal

Figure 28

WO 2015/144256 A1

## TRANSMISSION AND RECEPTION OF A RANDOM ACCESS PREAMBLE SIGNAL

## TECHNICAL FIELD

The present disclosure relates to random access in wireless communication systems, and in particular to a transmitter, a receiver, and to methods for transmitting and receiving random access preamble signals.

## BACKGROUND

The fourth generation, 4G, wireless access within the 3rd generation partnership project, 3GPP, long-term evolution, LTE, is based on orthogonal frequency-division multiplexing, OFDM, in downlink and discrete Fourier transform, DFT, spread OFDM, also known as single carrier frequency division multiple access, SC-FDMA, in uplink. Here, the uplink consists of the physical channels PUSCH, PUCCH, and PRACH and of the physical signals DMRS and SRS. According to the 3GPP specification, see, e.g., 3GPP TS 36.211 V11.3.0, the PUSCH, PUCCH, DMRS, and SRS all use an IFFT of size 2048 in the transmitter, with a sampling rate of 30.72 MHz. The same size of 2048 can be used for the FFT in the receiver. Dedicated hardware is commonly used for these FFTs. With another sampling rate than 30.72 MHz, the IFFT and FFT size will change accordingly.

The Physical Random-Access Channel, i.e., the PRACH, is used for initial access for a wireless device into the radio access network and also for timing offset estimation, i.e., estimation of timing offset between wireless device transmissions and reception at a base station. A description of this procedure is given in 3GPP TS 36.213 V11.3.0. An illustration of PRACH, as specified for LTE, see, e.g., 3GPP TS 36.211 V11.3.0, is given in Figure 1. Here five different formats, referred to in Figure 1 as Format 0 –Format 4, are specified where a PRACH preamble consists of one or two sequences, each of length 24 576 samples. The preambles have a cyclic prefix, CP, of length between 3 168 and 21 024 samples for formats 0 to 3.

Several methods have been proposed for how to detect the PRACH preambles transmitted by the UE, see e.g., S. Sesia. I. Toufik. M Baker "LTE, The UMTS Long Term Evolution, From Theory to Practice", Second Edition, John Wiley & Sons Ltd., 2011, where both a full frequency domain and a hybrid time-frequency approach are presented. In the full frequency domain  
5 approach the received signal is processed with an FFT corresponding to the length of the preamble. Hence, as shown in Figure 2, an FFT 203 of length 24 576 is thus required for each antenna. Dedicated hardware is commonly used for this PRACH FFT. After this large FFT, the PRACH bandwidth is extracted, which is a subset of the output from this large FFT.

In the hybrid time-frequency approach, a low-pass filter is first used in the time domain in  
10 order to extract the PRACH bandwidth. This lowpass filter is followed by an FFT of a size much smaller than 24 576. However, one such low-pass filter has to be applied to each antenna signal.

Consequently, as illustrated by Figures 1 and 2, the PRACH preamble as specified in LTE Release 8 covers a time interval which is much longer than the length of OFDM symbols used  
15 for other transmissions such as user data symbols. Current PRACH preamble receivers are thus designed under the assumption that propagation conditions are not varying significantly during the length of the preamble. This may be problematic, since assumptions, or constraints, are placed on the communication system. These constraints include expectations on low UE speed, i.e., Doppler spread, low frequency errors and low Doppler shifts, and also low phase  
20 noise in transmitters and receivers.

Thus, there is a need for an improved PRACH signaling technique, i.e., a preamble transmitter and receiver, which does not place or otherwise imply the above mentioned constraints on the communication system.

With currently emerging technologies, such as 5G communication systems, the use of many  
25 antenna elements is of great interest. As illustrated in Figure 3, the antenna signals can come from several antenna polarizations 304. Here, the antenna signals 305 are first received in a Radio Unit, RU, 306. The signals are then sampled and quantized in an Analog-to-Digital Converter, ADC, 307. A transformation from time to frequency domain is done using an FFT module 308, or, alternatively by a DFT module not shown in Figure 3, after which a PRACH

receiver 309 is applied to detect a preamble comprised in the received radio, i.e., antenna, signals. Here, an FFT is typically calculated for each antenna or for each subset of antennas, such that different users and channels in different sub-bands of the received signal can be extracted before further signal processing.

5 Figure 3 illustrates current PRACH receivers having multiple antennas. Figure 3 visualizes that with a large number of receiver antennas 310, the amount of FFT processing in the receiver is also large, which is generally a drawback. With dedicated antenna-signal processing only used for PRACH, a significant amount of special hardware for PRACH must be included, which hardware causes increased material cost as well as increased energy consumption. Also,  
10 running PRACH-specific antenna-signal processing consumes power and requires cooling capacity. Consequently, there is a need for a PRACH receiver better suited for multiple-antenna operation.

In order to increase received signal strength, a beamforming procedure can be used in which several antenna signals are scaled, phase shifted, and added before the PRACH receiver 309 is  
15 applied. Beamforming aims at combining received signals from several antennas such that more signal energy is received in specific spatial directions. Several beams can be formed in order to beamform towards different spatial directions. With two polarizations, the antenna signals from each polarization are typically beamformed separately. The same, or different, beamforming can be applied to the different polarizations.

20 This beamforming 411 can be done in the frequency domain, i.e., after the FFT 408, as illustrated in Figure 4. After the FFT 408, the individual sub-carriers can be extracted such that different physical channels and signals can be extracted. With digital beamforming 411 in the frequency domain, the antenna signals are first processed with an FFT 408 and then beamformed 411. In this manner, different sub-carriers can be beamformed differently. This  
25 allows for different beamforming for different physical channels and signals. Also, if several UEs are multiplexed in frequency, then these can be processed with individual beamforming.

However, with digital beamforming, a specific PRACH FFT has to be calculated for each receiver antenna, before extracting the PRACH bandwidth and beamforming into a smaller amount of signals. This is potentially a drawback due to the added signal processing required.

Alternatively, the beamforming can be done in the time domain 511b, as shown in Figure 5. Here, the beamforming is done on a digital signal, i.e., after analog-to-digital conversion by the ADC 507. However, since the FFT 508 is calculated after the beamforming 511b, all sub-carriers are beamformed in the same spatial direction, which is a potential drawback in some scenarios, e.g., where UEs are spread out over a large area.

An alternative time-domain beamforming 611c is illustrated in Figure 6, where the beamforming 611c is done before ADC 607. Here, the beamforming is done on an analog signal, i.e., before analog-to-digital conversion by the ADC 607.

Combinations of analog and digital beamforming and time- and frequency-domain beamforming are also possible.

With analog beamforming, such as the beamforming illustrated in Figure 6, the number of spatial directions for PRACH is limited by the number of analog beamformers. In LTE release 8, the PRACH preamble, and thus also the PRACH FFT, spans almost a whole sub-frame. The analog beamforming must therefore be fixed during a whole sub-frame which limits the number of beamforming directions.

Hence, present solutions for receiving PRACH and performing UE initial access and timing offset estimation are costly in terms of extra hardware and design effort, as well as in increased energy consumption and signal processing resources. Furthermore, improvements in the interworking between PRACH reception and beamforming in multiple antenna systems are preferred in order to reduce complexity of implementation.

It is an object of the present disclosure to provide solutions to, or at least mitigate, the above mentioned deficiencies in the art.

## SUMMARY

An object of the present disclosure is to provide at least a transmitter, a receiver, and methods for transmitting and receiving random access preamble signals, which seeks to mitigate, alleviate, or eliminate one or more of the above-identified deficiencies in the art and disadvantages singly or in any combination.

This object is obtained by a preamble transmitter comprising:

- a short sequence generator arranged to generate a short sequence  $s(n)$ , and
- a preamble sequence generator adapted to construct a preamble sequence by concatenating a plurality of said short sequences in time, as well as
- 5 – a transmitter unit arranged to transmit the generated preamble sequence as a radio signal.

The short sequence  $s(n)$  has the same time duration as an OFDM symbol used for carrying data traffic in a radio access network of the preamble transmitter.

Thus, by the present technique, there is no need for a special FFT used for receiving preambles  
10 in an uplink receiver of the transmitted radio signal.

According to an aspect, the preamble transmitter is further arranged to transmit the preamble sequence over a Physical Random Access Channel, PRACH, of a radio access network.

Thus, by the present technique, there is no need for a special PRACH FFT in the uplink receiver of the transmitted radio signal.

15 The object is also obtained by a preamble receiver arranged to receive radio signals comprising a preamble sequence. The preamble receiver comprises:

- at least one antenna element and corresponding radio unit configured to receive a radio signal, and
- at least one analog to digital converter, ADC, configured to perform analog to digital  
20 conversion of the received radio signal, as well as
- at least one FFT module arranged to determine a Fast Fourier Transform of the analog to digital converted signal, and also
- at least one detector adapted to detect the preamble sequence based on the determined FFT.

25 The preamble sequence comprises a concatenation in time of a plurality of short sequences  $s(n)$ , where each such short sequence  $s(n)$  has the same time duration as an OFDM symbol used for carrying data traffic in a radio access network of the preamble receiver. Also, the size of the FFT used for detecting the preamble signal is of the same size as one used for detecting an OFDM symbol carrying data traffic in a radio access network.

Thus, by the present technique, there is no need for a special FFT used for receiving preambles in the uplink receiver. This is especially important if FFT operations are performed for a large number of receiver antennas, as will become apparent from the present disclosure.

According to an aspect, the preamble receiver is further arranged to use one FFT hardware  
5 resource and FFT configuration both for detecting OFDM symbols carrying data, and also for detecting preamble sequences.

Thus, by the present technique, there is no special PRACH FFT in the preamble receiver.

According to one aspect, the preamble receiver comprises a preamble detector arranged to determine a plurality of FFTs from a plurality of FFT windows, and to non-coherently combine  
10 the FFT results into a combined received preamble signal.

According to another aspect, the preamble receiver comprises a preamble detector arranged to determine a plurality of FFTs from a plurality of FFT windows, and to coherently combine the FFT results into a combined received preamble signal.

Thus, by the feature of the preamble detector arranged to determine a plurality of FFTs from a plurality of FFT windows, and to coherently combine FFT results, there is provided a preamble  
15 receiver which is robust to high UE speeds, i.e., large Doppler spreads, and also to large frequency errors and high phase noise.

According to an aspect, the preamble receiver is arranged for beamforming. The beamforming weights are configured to change between FFT windows such that the number of spatial  
20 directions for which preamble detection is done is increased.

According to an aspect, the preamble receiver comprises hardware support for more than one simultaneous analog beamforming configuration, the preamble receiver being adapted for switching at a first switching rate between spatial directions with one beamforming configuration, and for switching at a second switching rate between spatial directions with  
25 another beamforming configuration, the first rate being different from the second rate.

Consequently, there is herein provided support for an increased number of beamforming directions if switching beamforming between FFT windows.

There is also provided herein a combined fast beamforming switching and slow beamforming switching. This means that both UEs with high and low SNR can be detected, albeit the latter with a larger delay.

According to an aspect, a single IFFT is applied per beam direction and polarization.

- 5 According to an aspect, the preamble receiver is arranged to perform simultaneous beamforming and matched filtering by a comprised joint filter.

Thus, the present technique provides for low computational complexity in the receiver, since coherent accumulation of the matched filter outputs from different FFT windows is possible

- 10 There is furthermore provided a technique which enables using only one IFFT per beam direction and polarization in a beamforming system, as well as simultaneous beam-forming and matched filtering.

There is also disclosed a preamble transmitter and receiver system, comprising at least one preamble transmitter and at least one preamble receiver as disclosed herein.

- 15 The object is also obtained by a network node comprising the preamble receiver according to any of the aspects disclosed herein.

The object is further obtained by a method performed in a preamble transmitter for transmitting a preamble sequence. The method comprises the steps of

- 20
- generating a short sequence  $s(n)$ , the short sequence having the same time duration as an OFDM symbol used for carrying data traffic in a radio access network of the preamble transmitter,
  - constructing a preamble sequence by concatenating a plurality of said short sequences in time, and
  - transmitting the constructed preamble sequence as a radio signal to a preamble receiver.

- 25 The object is additionally obtained by a method performed in a preamble receiver for receiving a radio signal and detecting a preamble sequence comprised in the radio signal. The method comprises the steps of

- receiving a radio signal comprising a preamble signal constructed from a plurality of short sequences  $s(n)$  via at least one antenna element and radio unit, the short sequence  $s(n)$  having the same time duration as an OFDM symbol used for carrying data traffic in a radio access network of the preamble transmitter,
- 5 – performing analog to digital conversion of the radio signal by an ADC comprised in the preamble receiver, and
- determining a Fast Fourier Transform, FFT, of the analog to digital converted signal, wherein the size of the FFT used for detecting the preamble signal is of the same size as for detecting an OFDM symbol used for carrying data traffic in a radio access  
10 network, as well as
- detecting the preamble sequence based on the determined FFT.

According to an aspect, the step of determining an FFT further comprises determining an FFT having a single configuration for detecting OFDM symbols carrying data, and also for detecting preamble sequences.

- 15 According to an aspect, the step of detecting comprises determining a plurality of FFTs from a plurality of FFT windows, and also non-coherently combining the FFT results into a combined received preamble signal.

- According to an aspect, the step of detecting comprises determining a plurality of FFTs from a plurality of FFT windows, and also coherently combining the FFT results into a combined  
20 received preamble signal.

There is also provided a computer program comprising computer program code which, when executed in a preamble transmitter, causes the preamble transmitter to execute a method according to aspects disclosed herein.

- There is further provided a computer program comprising computer program code which,  
25 when executed in a preamble receiver, causes the preamble receiver to execute a method according to aspects disclosed herein.

The computer programs and the methods display advantages corresponding to the advantages already described in relation to the preamble transmitter and receiver.

## BRIEF DESCRIPTION OF THE DRAWINGS

Further objects, features, and advantages of the present disclosure will appear from the following detailed description, wherein some aspects of the disclosure will be described in more detail with reference to the accompanying drawings, in which:

5 Figures 1-2 are signaling diagrams illustrating exchange of signals in embodiments of a network according to prior art.

Figures 3-6 are block diagrams illustrating embodiments of a receiver system according to prior art.

Figure 7 is a signaling diagram illustrating exchange of signals in an embodiment of a network.

10 Figure 8 is a flowchart illustrating embodiments of method steps performed in a preamble transmitter.

Figure 9 is a signaling diagram illustrating exchange of signals in an embodiment of a network.

Figure 10 is a flowchart illustrating embodiments of method steps performed in a preamble receiver.

15 Figures 11-13 are signaling diagrams illustrating exchange of signals in embodiments of a network.

Figures 14-25 are block diagrams illustrating embodiments of a receiver system.

Figure 26 is a block diagram illustrating embodiments of a transmitter system.

Figure 27 is a block diagram illustrating embodiments of a receiver system.

20 Figures 28-30 are flowcharts illustrating embodiments of method steps.

## DETAILED DESCRIPTION

Aspects of the present disclosure will be described more fully hereinafter with reference to the accompanying drawings. The apparatus, computer program and methods disclosed herein  
25 can, however, be realized in many different forms and should not be construed as being limited to the aspects set forth herein. Like numbers in the drawings refer to like elements

throughout, except for prefix digits in the number which represent the figure in which the element is to be found.

The terminology used herein is for the purpose of describing particular aspects of the disclosure only, and is not intended to limit the invention. As used herein, the singular forms  
5 "a", "an" and "the" are intended to include the plural forms as well, unless the context clearly indicates otherwise.

### *Abbreviations*

|    |       |  |
|----|-------|--|
|    | 3GPP  | 3rd Generation Partnership Project         |
| 10 | 4G    | Fourth Generation                          |
|    | 5G    | Fifth Generation                           |
|    | ADC   | Analog-to-Digital Converter                |
|    | BF    | Beam forming                               |
|    | DFT   | Discrete Fourier Transform                 |
| 15 | DL    | Downlink                                   |
|    | DM-RS | Demodulation reference signal              |
|    | FDD   | Frequency Division Duplex                  |
|    | FFT   | Fast Fourier Transform                     |
|    | IDFT  | Inverse Discrete Fourier Transform         |
| 20 | IFFT  | Inverse Fast Fourier Transform             |
|    | LTE   | Long Term Evolution                        |
|    | MF    | Matched Filter                             |
|    | OFDM  | Orthogonal frequency-division multiplexing |
|    | PBCH  | Physical broadcast channel                 |
| 25 | PRACH | Physical random access channel             |

|    |         |   |
|----|---------|---|
|    | PRB     | Physical Resource Block                             |
|    | PSS     | Primary Synchronization Signal                      |
|    | PUCCH   | Physical uplink control channel                     |
|    | PUSCH   | Physical uplink shared channel                      |
| 5  | RB      | Resource Block                                      |
|    | RBS     | Radio Base Station                                  |
|    | RU      | Radio Unit  |
|    | SC      | Sub-Carrier   |
|    | SC-FDMA | Single Carrier – Frequency Division Multiple Access |
| 10 | SNR     | Signal to Noise Ratio                               |
|    | SRS     | Sounding Reference Signal                           |
|    | SSS     | Secondary Synchronization Signal                    |
|    | TDD     | Time Division Duplex                                |
|    | UE      | User Equipment                                      |
| 15 | UL      | Uplink  |
|    | ZC      | Zadoff-Chu  |

A preamble receiver, e.g., for receiving signals on the PRACH, is proposed herein in which FFTs of the same size as for other uplink channels and signals are used. The preamble receiver  
20 discussed herein constitutes part of a receiver in a wireless communication system, such as an LTE or 5G RBS.

In other words, the preamble receiver 2741, 1548 disclosed herein is arranged to use one FFT hardware resource and FFT configuration both for detecting OFDM symbols carrying data, and also for detecting preamble sequences.

The preamble sequence discussed herein can be used for a variety of purposes, including but not limited to initial access, handover, scheduling requests, and resynchronization.

The PRACH preamble used is based on several concatenated short sequences, where each short sequence has the same length as the length of the OFDM symbols used for all other  
5 physical channels. The preamble sequence is constructed by repeating the short sequence a number of times to make the preamble sequence. Consequently, the short sequence used to construct the preamble sequence works as a cyclic prefix to its neighbors, as will be further detailed below.

Further, in the preamble detector proposed herein, several received signals from different FFT  
10 windows can be combined. Different combinations of these FFT windows are proposed depending of the amount of phase noise, frequency errors, and UE speed.

The proposed technique is applicable in multi-antenna systems implementing beamforming. For analog beamforming systems, the beamforming weights are, according to an aspect, changed between each FFT window such that the number of spatial directions is increased for  
15 which preamble detection is done. With hardware support from more than one simultaneous analog beamforming resource, then one beamforming resource can be used for fast switching between spatial directions while the other can have a slow switching rate allowing more accumulated preamble energy in each direction.

Thus, by the present technique, no special PRACH FFT is necessary in the uplink receiver. This  
20 is especially important if FFT operations are performed for a large number of receiver antennas, due to the significant savings in, e.g., hardware processing resources.

Furthermore, the present technique facilitates receiver implementations with reduced computational complexity compared to current PRACH receiver systems. For instance,

- Coherent accumulation of matched filter outputs from different FFT windows is  
25 possible,
- There is only one IFFT per beam direction and polarization in a system with beamforming,

- It is possible to perform simultaneous beam-forming and matched filtering by a joint filter structure.

Another potential benefit of the present teaching is that a preamble detector is provided which is robust towards high UE speed, i.e. Doppler spread, large frequency errors, i.e., large  
5 Doppler shifts, and severe phase noise.

Yet another potential advantage of the present technique is an increased number of beamforming directions for analog beamforming if switching beamforming between FFT windows, which is especially beneficial for UEs with high SNR, e.g., those close to the eNodeB.

10 Additionally, there is provided combined fast beamforming switching and slow beamforming switching, wherein both UEs with high and low SNR can be detected, albeit the latter with a larger delay.

Figure 7 shows a signaling diagram 712 illustrating timing in a communication system implementing Time Division Duplex, TDD.

15 In a TDD system, the same frequency is used both for downlink and uplink. Both the UE and the eNodeB must then switch between transmitting and receiving, assuming that full duplex operation is not possible.

The present teaching is focused on a TDD mode of operation. However, the technique disclosed herein also directly applies to FDD (Frequency-Division Duplex) systems. For FDD systems the problem descriptions related to switch time between transmission and receptions  
20 do not apply.

A dynamic TDD system is according to aspects configured with a few sub-frames 713 that are fixed for downlink, i.e., they cannot be used for uplink, see illustration in Figure 7. These sub-frames are used, e.g., for transmitting synchronization signals and broadcasting control messages used for initial downlink synchronization, continuous downlink synchronization, and  
25 call setup. A dynamic TDD system can also be configured with fixed uplink sub-frames 714. Such sub-frames can, e.g., be used for PRACH to support initial access and uplink synchronization. Note that Figure 7 is based on a radio-frame of length 10 ms, which is divided into 50 sub-frames, each of length 0.2 ms. This is in contrast to LTE Release 8 where a radio-frame is split into 10 sub-frames, each of length 1 ms.

Thus, according to an aspect, there is disclosed a method for receiving the type of preamble sequence disclosed herein in connection to the preamble transmitter, which method is not necessarily limited to a specific radio frame length or sub-frame division.

Figure 8a shows a flow chart illustrating a procedure for initial set-up of a UE in a radio access network, where PSS and SSS are transmitted in subframe 0 and 25 in a dynamic TDD system.

Figure 8b shows a flow chart where the steps in Figure 8a have been put into one example context, further discussed in connection to Figure 28 below.

The methods illustrated in Figures 8a and 8b are arranged to be performed by a preamble transmitter 2636 which will be further discussed in connection to Figure 26 below. This preamble transmitter comprises:

- a short sequence generator 2650 arranged to generate a short sequence  $s(n)$ , and
- a preamble sequence generator 2637 adapted to construct a preamble sequence by concatenating a plurality of said short sequences in time, as well as
- a transmitter unit 2639a,b arranged to transmit the generated preamble sequence as a radio signal.

The short sequence  $s(n)$  has the same time duration as an OFDM symbol used for carrying data traffic in a radio access network of the preamble transmitter 2636.

Turning now to Figure 28, which illustrates a method performed in a preamble transmitter 2636 for transmitting a preamble sequence, the method comprising the steps of

- generating S11 a short sequence  $s(n)$ , the short sequence having the same time duration as an OFDM symbol used for carrying data traffic in a radio access network of the preamble transmitter 2636,
- constructing S12 a preamble sequence by concatenating a plurality of said short sequences in time, and
- transmitting S13 the constructed preamble sequence as a radio signal to a preamble receiver.

Thus, at initial setup, a UE starts by receiving and synchronizing to downlink synchronization signals 815. As an example, in LTE, the UE starts by detecting the PSS, or Primary

Synchronization Signal, after which the UE will attain a sub-frame synchronization, OFDM symbol synchronization, and know the cell identity, cell ID, group. Then the UE detects SSS, or Secondary Synchronization Signal, after which the UE is frame synchronized and knows the cell ID.

- 5 The UE, i.e., the preamble or PRACH transmitter, is then according to some aspects configured by receiving and detecting system information 816 carried by a broadcast signal. In LTE, this broadcast information is carried by PBCH, or Physical Broadcast Channel. This broadcast information can relate to time and frequency allocation of PRACH, such that the UE knows when and where it is allowed to transmit PRACH preambles. This is further illustrated in Figure  
10 9, where the UE can transmit PRACH 918 in sub-frame 5, which in this TDD system is a fixed allocation to uplink transmissions. Also, the UE can be configured by broadcast information or preconfigured with timing information of when within a sub-frame it may transmit the preamble.

Based on broadcast information, or preconfigured in the UE according to specification, a  
15 PRACH preamble signal is constructed in the UE and transmitted 817.

A corresponding illustration for an eNodeB, i.e., the preamble or PRACH receiver, is given in Figure 10a.

Figure 10b shows a flowchart where the steps in Figure 10a have been put into one example context, further discussed in connection to Figure 29 below.

- 20 The methods illustrated in Figures 10a and 10b are arranged to be performed by a preamble receiver 2741, 1447 which will be further discussed in connection to Figures 14 and 27 below.

This preamble receiver comprises:

- at least one antenna element 1410 and corresponding radio unit 1406, configured to receive a radio signal, and
- 25 - at least one analog to digital converter, ADC, 1407 configured to perform analog to digital conversion of the received radio signal, as well as
- at least one FFT module 1408 arranged to determine a Fast Fourier Transform, of the analog to digital converted signal, and also

- at least one detector 1428 adapted to detect the preamble sequence based on the determined FFT.

Turning now to Figure 29, which illustrates a method performed in a preamble receiver 2741, 1447 for receiving a radio signal and detecting a preamble sequence comprised in the radio

5 signal, the method comprising the steps of

- receiving S21 a radio signal comprising a preamble signal constructed from a plurality of short sequences  $s(n)$  via at least one antenna element 1410 and radio unit 1406, the short sequence  $s(n)$  having the same time duration as an OFDM symbol used for carrying data traffic in a radio access network of the preamble transmitter 2636,
- 10 - performing S22 analog to digital conversion of the radio signal by an ADC 1407 comprised in the preamble receiver, and
- determining S23 a Fast Fourier Transform, FFT, 1408 of the analog to digital converted signal, wherein the size of the FFT used for detecting the preamble signal is of the same size as for detecting an OFDM symbol used for carrying data traffic in a radio access
- 15 network, as well as
- detecting S24 the preamble sequence based on the determined FFT.

Thus, the received preamble sequence comprises a concatenation in time of a plurality of short sequences  $s(n)$ . Each such short sequence  $s(n)$  has the same time duration as an OFDM symbol used for carrying data traffic in a radio access network of the preamble receiver 2741, 1447. Thus, the size of the FFT used for detecting the preamble signal is preferably of the same

20 size as one used for detecting an OFDM symbol carrying data traffic in a radio access network.

#### *Preamble construction in UE*

Turning now to the details of how a preamble is constructed in the UE, i.e., in the preamble

25 transmitter disclosed herein.

An example embodiment of a preamble transmitter 2636 arranged to perform the steps disclosed below is shown in Figure 26.

The preamble sequence depends on the PRACH frequency allocation, such that the number of sub-carriers,  $N_{seq}$ , allocated for PRACH equals the maximum number of symbols. For example, with LTE nomenclature, 6 resource blocks are allocated to PRACH, which correspond to 72 sub-carriers.

- 5 A short sequence can, e.g., be constructed by using Zadoff-Chu sequences. The  $u$ :th root Zadoff-Chu sequence is defined in 3GPP TS 36.211 V11.3.0 as

$$x_u(n) = e^{-j\frac{\pi un(n+1)}{N_{ZC}}}, \quad 0 \leq n \leq N_{ZC} - 1 \quad (1)$$

where the length  $N_{ZC}$  of the Zadoff-Chu sequence is a prime number. For a PRACH allocation of 72 sub-carriers, the sequence length can, e.g., be set to 71.

- 10 Thus, the short sequence, at times referred to herein as  $s(n)$ , comprises a Zadoff-Chu sequence.

A time-continuous short random-access signal  $s(t)$  is defined by

$$s_{short}(t) = \beta_{PRACH} \sum_{k=0}^{N_{seq}-1} \sum_{n=0}^{N_{seq}-1} x_u(n) \cdot e^{-j\frac{2\pi nk}{N_{seq}}} \cdot e^{j2\pi(k+k_0)\Delta f t} \quad (2)$$

- where  $0 \leq t < T_{short}$ ,  $N_{seq} = 71$ ,  $\beta_{PRACH}$  is an amplitude-scaling factor in order to conform to  
 15 the transmit power of PRACH,  $k_0 = n_{PRB}^{RA} N_{sc}^{RB} - N_{RB}^{UL} N_{sc}^{RB} / 2$ , and  $\Delta f$  is the sub-carrier spacing. The location in the frequency domain is controlled by the parameter  $n_{PRB}^{RA}$ ; the resource block size in the frequency domain, expressed as a number of subcarriers, is denoted by  $N_{sc}^{RB}$ , and the uplink bandwidth configuration, expressed in multiples of  $N_{sc}^{RB}$ , is denoted by  $N_{RB}^{UL}$ . Using a Zadoff-Chu sequences implies that  $N_{seq} = N_{ZC}$ .

- 20 A short sequence of the same length as the OFDM symbol is achieved by  $T_{short} = 1/\Delta f$ . For LTE Release 8, this sub-carrier spacing equals  $\Delta f = 15$  kHz, see Table 6.2.3-1 in 3GPP 36.211 V11.3.0, such that the length of the short sequence equals  $T_{short} = 66.6 \mu s$ . With a change in subcarrier spacing to, e.g.,  $\Delta f = 75$  kHz, then the length of the short symbol equals  $T_{short} = 13.3 \mu s$ .

Thus, the short sequence  $s(n)$  has the same time duration as an OFDM symbol used for carrying data traffic in a radio access network of the preamble transmitter 2636.

The preamble to be transmitted is constructed by

$$s(t) = s_{short}((t - T_{CP}) \bmod(T_{short})) \quad (3)$$

5 where  $0 \leq t < T_{SEQ}$ , and  $T_{CP}$  is the length of a possible cyclic prefix.

Figure 11 provides an illustration 1122 of the short sequences  $s(n)$ . By this repetition of the short sequence, each short sequence will act as a cyclic prefix for the next short sequence. Here, the short sequence is repeated 15 times, and succeeded by a smaller part of the short sequence. This last part of the short sequence is inserted in the end such that the preamble  
10 covers the whole length of the last receiver FFT window.

Consequently, the short sequence used to construct the preamble sequence is arranged as cyclic prefix for neighboring short sequences.

A preamble sequence 1223 suited for a TDD (Time-Division Duplex) system is illustrated in Figure 12, see also Figure 13. Here, the preamble is shortened such that it begins later  
15 compared to the case shown in Figure 11.

#### *Preamble detector in eNodeB*

Turning now to the details of how a preamble is detected in an eNodeB, i.e., in the preamble receiver.

20 A network node 2740 comprising a preamble receiver 2741 arranged to perform the steps disclosed below is shown in Figure 27.

A receiver structure for preamble detection is illustrated in Figure 14. Here, the radio signals 1405 from the antenna elements 1410 are received in radio units 1406, followed by an Analog-to-Digital Conversion, ADC, 1407.

25 Model the radio transmission from mobile to base-station, for receiver antenna number  $a$  by an L tap FIR filter  $h(m,a)$

$$r(n, a) = \sum_{m=0}^{L-1} h(m, a)x(n - m - d) + w(n, a) + \tilde{w}(n, a) \quad (4)$$

Where  $x(n)$  is the transmitted sequence,  $w(n, a)$  is additive white Gaussian noise with variance  $2\sigma_w^2(a)$ ,  $\tilde{w}(n, a)$  is interference, and  $d$  corresponds to a round-trip delay for current mobile.

This round-trip delay is limited by the cell radius, i.e.,

$$5 \quad 0 \leq d \leq D - 1, \quad (5)$$

where

$$D = \left\lfloor \frac{2 \times R_{\text{cell}}}{3 \cdot 10^5} F_s \right\rfloor \quad (6)$$

and  $R_{\text{cell}}$  is the cell radius in kilometers,  $F_s$  is the sampling rate, and  $\lfloor x \rfloor$  denotes rounding towards nearest lower integer.

10 These time-domain signals are inputs to Fast Fourier Transforms, FFT, 1408 as illustrated in Figure 14. See also illustrations in Figures 15 and 16 where the input signals to the FFT processing, i.e., the FFT windows 1530, 1630 are illustrated. The FFT window positions  $n_s(p)$  correspond to the distance in time between the start of the first short sequence and each SC-FDMA or OFDM symbol in uplink, see illustration in Figure 17. In this illustration, the start of  
 15 the first short sequence is placed at the start of the subframe. For example, in LTE Release 8, the first cyclic prefix in each slot is 160 samples, while the remaining cyclic prefixes are 144 samples. Each SC-FDMA or OFDM symbol is 2048 samples such that the values of  $n_s(p)$  as in Table 1 below follow.

| $p$ | $n_s(p)$ [samples]   |
|-----|----------------------|
| 0   | 160                  |
| 1   | 160+144+2048         |
| 2   | 160+2*144+2*2048     |
| 3   | 160+3*144+3*2048     |
| 4   | 160+4*144+4*2048     |
| 5   | 160+5*144+6*2048     |
| 6   | 160+6*144+6*2048     |
| 7   | 2*160+6*144+7*2048   |
| 8   | 2*160+7*144+8*2048   |
| 9   | 2*160+8*144+9*2048   |
| 10  | 2*160+9*144+10*2048  |
| 11  | 2*160+10*144+11*2048 |
| 12  | 2*160+11*144+12*2048 |
| 13  | 2*160+12*144+13*2048 |

Table 1. Time shift in samples between sequential OFDM (or SC-FDMA) symbols.

*Non-coherent antenna accumulation*

For each antenna  $a$  and FFT window  $p$ , calculate a DFT or FFT over  $N_{FFT}$  samples:

$$5 \quad R(k, p, a) = \frac{1}{\sqrt{N_{FFT}}} \sum_{n=0}^{N_{FFT}-1} r(n + n_s(p), a) e^{-j2\pi kn / N_{FFT}} \quad (7)$$

for  $k = 0, \dots, N_{FFT} - 1$  and  $a = 0, \dots, N_a - 1$ .

The PRACH preamble in the frequency domain is obtained by extracting sub-carriers corresponding to those sub-carriers used for PRACH, i.e.  $N_{seq}$  samples, where  $N_{seq} \leq N_{FFT}$

$$R_{PRACH}(k, p, a) = R(k + k_0, p, a), \quad (8)$$

for  $k = 0, \dots, N_{seq} - 1$  and  $k_0 = n_{PRB}^{RA} N_{sc}^{RB} - N_{RB}^{UL} N_{sc}^{RB} / 2$ . Using the same notation as in previous  
5 section, and with the use of Zadoff-Chu sequences, then  $N_{seq} = N_{ZC}$ .

Thus, the preamble transmitter 2636 is according to an aspect, arranged to transmit the preamble sequence over a Physical Random Access Channel, PRACH, of a radio access network.

Multiply with a matched filter (of  $N_{seq}$  coefficients) in the frequency domain

$$10 \quad C_{MF,v}(k, p, a) = \frac{1}{\sqrt{N_{seq}}} P_v^*(k, p) \cdot R_{PRACH}(k, p, a). \quad (9)$$

This matched filter is constructed from the DFT of known short sequence and the cyclic shift of this short sequence. The cyclic shift corresponds to a frequency-domain rotation with the shift  $n_{shift}(p)$ :

$$P_v(k, p) = e^{j2\pi k n_{shift}(p) / N_{FFT}} \frac{1}{\sqrt{N_{seq}}} \sum_{n=0}^{N_{seq}-1} x_u(n) e^{-j2\pi k n / N_{seq}}. \quad (10)$$

15 The output from the matched filters corresponding to the same antenna, but from different FFT windows, can now be coherently added as

$$C_v(k, a) = \sum_{p=p_0}^{p_0+P-1} C_{MF,v}(k, p, a) \quad (11)$$

where  $p_0$  is the index of the first, out of  $P$ , FFT windows included in the PRACH preamble detector. See, e.g., figure 11 and 15 for which  $p_0 = 1$  and  $P = 12$ . For the format in figure 12 and 16, only FFT window 2 to 12 are used such that  $p_0 = 2$  and  $P = 11$ .

20 Thus, according to an aspect, the preamble receiver comprises a preamble detector arranged to determine a plurality of FFTs from a plurality of FFT windows, and to coherently combine the FFT results into a combined received preamble signal.

Now, in order to detect preamble and estimate round-trip time, the output from the IFFT will be transformed to the time domain. Calculate an IDFT, of size  $N_{IFFT}$ , resulting in a correlation vector of length  $N_{IFFT}$ :

$$c_v(m, a) = \frac{1}{\sqrt{N_{IFFT}}} \sum_{k=0}^{N_{seq}-1} C_v(k, a) e^{j2\pi km / N_{IFFT}} \quad (12)$$

for  $m=0, \dots, N_{IFFT}-1$ . Selecting  $N_{IFFT} > N_{seq}$  corresponds to an interpolation, which can be  
5 done in order to increase the resolution of the timing estimation.

A simple estimator of the noise variance  $\hat{\sigma}_w^2(a)$  can be formulated as

$$\hat{\sigma}_w^2(a) = \sum_{p=p_0}^{p_0+P-1} \sum_{k=0}^{N_{seq}-1} |C_{MF,v}(k, p, a)|^2. \quad (13)$$

As decision variables, the absolute square for each value of the cross-correlation vector is used, normalized with the estimated noise variance  $\hat{\sigma}_w^2(i)$ ,

$$10 \quad \lambda_v(m) = \sum_{a=0}^{N_a-1} \frac{|c_v(m, a)|^2}{\hat{\sigma}_w^2(a)} \quad (14)$$

where a summation over antennas, including polarizations, is included. A preamble detector and round-trip time estimator might be formulated as searching for the maximum value in this vector of normalized absolute squared correlations and comparing this maximum value with a threshold.

15 Preamble number  $v$  is detected if the absolute squared value of this autocorrelation exceeds a threshold

$$\lambda_v(m) = \sum_{a=0}^{N_a-1} \frac{|c_v(m, a)|^2}{\hat{\sigma}_w^2(a)} \geq \lambda_{Threshold} \quad (15)$$

for at least one value of  $m$ , within the search window of size  $D$ . In other words, the preamble with index  $v$  is detected if there is an  $m \in [0, D-1]$  such that  $\lambda_v(m) \geq \lambda_{Threshold}$ . This preamble  
20 detector threshold  $\lambda_{Threshold}$  should be selected with care such that the false detection rate is low without causing a too low detection rate.

A timing estimate follows as the value of  $m$  which corresponds to the maximum value of  $\lambda_v(m)$  i.e.

$$\hat{m} = \arg \max_m \left( \sum_{a=0}^{N_a-1} \frac{|c_v(m, a)|^2}{\hat{\sigma}_w^2(a)} \right) \quad (16)$$

such that the timing error in seconds equals

$$5 \quad \hat{T}_{err} = \hat{m} / (\Delta f \cdot N_{IFFT}) . \quad (17)$$

#### *Low-coherence case*

The coherent addition of signals in (11) should not be done when the coherence time is low. This coherence time is depending on the rate of time variation of all distortions between  
10 baseband transmitter and receiver. For example, a high Doppler spread will lead to a fast time-varying channel which decreases the coherence time. Also, large frequency errors or large phase noise leads to a decreased coherence time such that the time should be reduced for which the coherent addition is done.

15 Instead of adding all FFT windows coherently as in (11), a smaller number of FFT windows might be added, i.e.,

$$C_v(k, a, c) = \sum_{p=p_0}^{p_0+P-1} W_{coh}(p, c) \cdot C_{MF,v}(k, p, a) \quad (18)$$

where  $W_{coh}(p, c)$ ,  $c = 0, \dots, N_c - 1$  is used to control the coherence time. See for example figure 18 and 19, where only two FFT windows are coherently added

$$C_v(k, a, c) = \sum_{p=1+2c}^{2+2c} C_{MF,v}(k, p, a) \quad (19)$$

20 before the IFFT

$$c_v(m, a, c) = \frac{1}{\sqrt{N_{IFFT}}} \sum_{k=0}^{N_{seq}-1} C_v(k, a, c) e^{j2\pi km / N_{IFFT}} . \quad (20)$$

Note that figure 18 is an illustration where a few more repetitions of the short sequence are used as compared to figure 19. The decision variable can now be formulated as

$$\lambda_v(m) = \sum_{c=0}^{N_c-1} \sum_{a=0}^{N_a-1} \frac{|c_v(m, a, c)|^2}{\hat{\sigma}_w^2(a)}. \quad (21)$$

Thus, according to an aspect, the preamble receiver comprises a preamble detector arranged to determine a plurality of FFTs from a plurality of FFT windows, and to non-coherently combine the FFT results into a combined received preamble signal.

#### *Frequency-domain beam-forming*

A beamforming gain can be achieved if several antenna signals are coherently added with individual scaling and phase shifts. For frequency-domain beamforming, these scaling and phase shifts are applied after the FFT, see illustration in figure 20. Here, the signals from the antennas are connected to a Radio Unit (RU) followed by an ADC and FFT. Frequency-domain signals from many antennas after the FFT are then combined in a Beamforming (BF). In this way, the beamforming can be different for different sub-carriers. For example, one or several PRACH specific beamformings can be applied to those sub-carriers which are used for PRACH. By these beamformings, the PRACH preamble detector is sensitive in several spatial directions.

Denote the PRACH preamble in the frequency domain after extracting sub-carriers corresponding to those sub-carriers used for PRACH as

$$R_{PRACH}(k, p, a) = R(k + k_0, p, a). \quad (22)$$

The beamformed signal for beam number  $b$ , with the beamforming weights and phase shift factors denoted by  $W_{BF}(a, k, b)$  for sub-carrier  $k$  and antenna  $a$ , can be written as

$$R_{BF,PRACH}(k, p, b) = \sum_{a=0}^{N_a-1} W_{BF}(a, k, b) \cdot R_{PRACH}(k, p, a). \quad (23)$$

This beamformed signal is multiplied with a matched filter (of  $N_{seq}$  coefficients) in the frequency domain

$$C_{MF,v}(k, p, b) = \frac{1}{\sqrt{N_p}} P_v^*(k, p) \cdot R_{BF,PRACH}(k, p, b) \quad (24)$$

Here, the beamforming and the matched filtering can be done simultaneously in a single multiplication, i.e.,

$$C_{BFMF,v}(k, p, b) = \sum_{a=0}^{N_a-1} W_{BFMF}(k, p, a, b) \cdot R_{PRACH}(k, p, a) \quad (25)$$

5 where

$$W_{BFMF,v}(k, p, a, b) = \frac{1}{\sqrt{N_p}} W_{BF}(a, k, b) \cdot P_v^*(k, p) \quad (26)$$

which can be precalculated and stored in memory 2744.

The output from the matched filters corresponding to the same beamforming, but from different FFT windows, can now be coherently added as

$$10 \quad C_{BFMF,v}(k, b) = \sum_{p=p_0}^{p_0+P-1} C_{BFMF,v}(k, p, b) \quad (27)$$

where  $p_0$  is the index of the first FFT window included in the PRACH preamble detector.

Now, in order to detect preamble and estimate round-trip time, the output from the IFFT will be transformed to the time domain. Calculate an IDFT, of size  $N_{IFFT}$ , resulting in an correlation vector of length  $N_{IFFT}$

$$15 \quad c_{BFMF,v}(m, b) = \frac{1}{\sqrt{N_{IFFT}}} \sum_{k=0}^{N_{seq}-1} C_{BFMF,v}(k, b) e^{j2\pi km / N_{IFFT}} \quad (28)$$

Selecting  $N_{IFFT} > N_p$  corresponds to an interpolation which can be done in order to increase the resolution of the timing estimation.

A simple noise variance  $\hat{\sigma}_w^2(b)$  can be estimated as

$$\hat{\sigma}_w^2(b) = \frac{1}{PN_{seq}} \sum_{p=p_0}^{p_0+P-1} \sum_{k=0}^{N_{seq}-1} |C_{MF,v}(k, p, b)|^2. \quad (29)$$

As decision variable, an absolute square of each value of the cross-correlation vector is used, normalized with the estimated noise variance  $\hat{\sigma}_w^2(b)$ ,

$$\lambda_v(m, b) = \frac{|c_v(m, b)|^2}{\hat{\sigma}_w^2(b)}. \quad (30)$$

- 5 Here several polarizations might be added into the decision variable. A preamble detector and round-trip time estimator might be formulated as searching for the maximum value in this vector of normalized absolute squared correlations and comparing this maximum value with a threshold.

Preamble number  $v$  is detected if the absolute squared value of this autocorrelation exceeds a  
10 threshold

$$\lambda_v(m, b) = \frac{|c_v(m, b)|^2}{\hat{\sigma}_w^2(b)} \geq \lambda_{Threshold} \quad (31)$$

for at least one value of  $m$ , within the search window of size  $D$ . In other words, the preamble with index  $v$  is detected if there is an  $m \in [0, D-1]$  such that  $\lambda_v(m, b) \geq \lambda_{Threshold}$ . This preamble detector threshold  $\lambda_{Threshold}$  should be selected with care such that the false  
15 detection rate is low without causing a too low detection rate.

### *Time-domain beam-forming*

For time-domain beamforming, the beamforming scaling and phase shifts are applied 2131 before the FFT 2108, see illustration in Figure 21. Here, the signals 2105 from the antennas are  
20 connected to a Radio Unit, RU, 2106 and an Analog-to-Digital Converter, ADC 2107 followed by a beamforming, BF, 2131, after which the output from the beamforming is processed in an FFT 2108. Time-domain signals from many antennas are thus combined in the beamforming. In this way, the beamforming is the same for all sub-carriers. This beamforming might be done

on a digital signal, i.e., after the analog-to-digital converter, ADC, 2107 as in Figure 21 or on an analog signal, i.e., before ADC 2207, as in Figure 22.

At initial access, the eNodeB has limited knowledge of the position of the UE. The PRACH receiver must therefore evaluate several beamformings in order to be able to detect the PRACH preamble. With time-domain beamforming, this requires one sequence of processing from FFT to preamble detector per beamforming, see Figure 21 or 22. The beamforming and FFT support is costly in terms of hardware support and power consumption.

An illustration 2332 is given in Figure 23 of an approach in which the beamforming is changed between each FFT window. Here the outputs from each beamforming, followed by an FFT, are individually processed in a matched filter, an IFFT, an absolute square calculation, and finally a preamble detector. If the hardware supports several simultaneous beamformings in the same time-window, then several spatial directions can be processed, see figure 21 or 22. Each such beamforming is referred to as one baseband, BB, port.

An alternative configuration is illustrated 2433 in Figure 24. Here, one BB port is used with a fixed time domain beamforming for all time windows of a sub-frame. A second BB port is used to switch beamformings between each window.

Typically, the number of FFT windows for which the analog beamforming is constant equals the number of FFT windows which are included in the same PRACH preamble detection. The number of included FFT windows for a given beam improves the performance of the PRACH preamble detection in terms of improved detection rate.

For UEs with high SNR, i.e., typically located close to the eNodeB, a reliable detection can thus be done with a small number of FFT windows, while UEs with a low SNR, typically located further away from the eNodeB, can in most cases only be done if many, or all, FFT windows are included. By combining detectors with few FFT windows included, i.e., with many different beamforming directions, and detectors with many FFT windows but few beamforming directions, a balance can be achieved between fast preamble detectors with high SNR and slow detection for UEs with low SNR. That is, many PRACH occasions might be needed for UEs with low SNR. This since the baseband ports with many FFT windows included do not search all PRACH directions during each PRACH occasion.

Hence, the present teaching facilitates utilizing the multiple base band ports for different ranges of preamble detection. In Figure 25, an example is shown where port 0 uses a single FFT window but scans all 12 beams in this example, which point in unique directions in elevation and/or azimuth. Port 1 on the other hand scans every other beam while using double FFT windows. Port 2 scans every fourth beam using four FFT window aggregations. If the beams are narrow, there may be a risk that a UE is located between two scanned beams, which lead to a large SNR loss which cannot be recovered by the doubling of FFT windows. So there is a trade off in down selection of the number of used beams in the preamble search procedure and the increased number of FFT windows. To mitigate this in this example, port 3 uses also every fourth beam and four FFT windows but where the beam pointing directions are interlaced with the beams used for port 2. Hence it is part of the present disclosure that different base band ports scan interlaced beams.

Note that it is possible to use a single index to indicate beams, whereas in reality the beam can in general be pointed in both azimuth and elevation directions.

Consequently, according to an aspect, the preamble receiver disclosed herein is arranged for beamforming, wherein the beamforming weights are configured to change between FFT windows such that the number of spatial directions for which preamble detection is done is increased.

Also, the preamble receiver, according to aspects, comprises hardware support for more than one simultaneous analog beamforming configuration, the preamble receiver being adapted for switching at a first switching rate between spatial directions with one beamforming configuration, and for switching at a second switching rate between spatial directions with another beamforming configuration, the first rate being different from the second rate.

Further, according to aspects, a single IFFT is applied per beam direction and polarization, and the preamble receiver can also be arranged to perform simultaneous beam-forming and matched filtering by a comprised joint filter.

There is further disclosed herein a preamble transmitter and receiver system, comprising at least one preamble transmitter according to the present teaching, and at least one preamble receiver according to the present teaching.

Figure 26 shows a preamble transmitter 2636 arranged to construct a preamble signal by a preamble sequence generator 2637 connected to a memory unit 2638, and also to transmit the generated preamble signal via a communications interface 2639a, 2639b of the preamble transmitter 2636. The preamble transmitter 2636 is, according to an aspect, a UE in an LTE network.

Figure 27 shows a network node 2740 comprising a preamble receiver 2741 arranged to receive a radio signal from a preamble transmitter and to detect a preamble signal comprised in the radio signal. The preamble receiver 2741 is connected to a communications interface 2742 comprised in the network node 2740, and to a controller unit 2743 adapted to perform method steps of the present teaching. The network node 2740 further comprises a memory unit 2744.

Also, the present disclosure comprises a network node 2740 comprising the preamble receiver 2741 according to the present teaching.

Figures 28-30 are flowcharts illustrating embodiments of method steps, which method steps will now be further detailed.

Figure 28 illustrates a method performed in a preamble transmitter 2636 for transmitting a preamble sequence, the method comprising the steps of

- generating S11 a short sequence  $s(n)$ , the short sequence having the same time duration as an OFDM symbol used for carrying data traffic in a radio access network of the preamble transmitter 2636,
- constructing S12 a preamble sequence by concatenating a plurality of said short sequences in time, and
- transmitting S13 the constructed preamble sequence as a radio signal to a preamble receiver.

Figure 29 illustrates a method performed in a preamble receiver 2741, 1447 for receiving a radio signal and detecting a preamble sequence comprised in the radio signal, the method comprising the steps of

- receiving S21 a radio signal comprising a preamble signal constructed from a plurality of short sequences  $s(n)$  via at least one antenna element 1410 and radio unit 1406, the short sequence  $s(n)$  having the same time duration as an OFDM symbol used for carrying data traffic in a radio access network of the preamble transmitter 2636,
- 5 – performing S22 analog to digital conversion of the radio signal by an ADC 1407 comprised in the preamble receiver, and
- determining S23 a Fast Fourier Transform, FFT, 1408 of the analog to digital converted signal, wherein the size of the FFT used for detecting the preamble signal is of the same size as for detecting an OFDM symbol used for carrying data traffic in a
- 10 radio access network, as well as
- detecting S24 the preamble sequence based on the determined FFT.

According to an aspect, the step of determining S23 an FFT further comprises determining an FFT having a single configuration for detecting OFDM symbols carrying data, and also for detecting preamble sequences.

- 15 According to another aspect, the step of detecting S24 comprises determining a plurality of FFTs from a plurality of FFT windows, and also non-coherently combining the FFT results into a combined received preamble signal.

According to a further aspect, the step of detecting S24 comprises determining a plurality of FFTs from a plurality of FFT windows, and also coherently combining the FFT results into a

20 combined received preamble signal.

In other words, there is disclosed herein:

A preamble transmitter 2636 comprising:

- a short sequence generator 2650 arranged to generate a short sequence  $s(n)$ , and
- a preamble sequence generator 2637 adapted to construct a preamble sequence by
- 25 concatenating a plurality of said short sequences in time, as well as
- a transmitter unit 2639a,b arranged to transmit the generated preamble sequence as a radio signal,

the short sequence  $s(n)$  having the same time duration as an OFDM symbol used for carrying data traffic in a radio access network of the preamble transmitter 2636.

A preamble transmitter 2636 arranged to transmit the preamble sequence over a Physical Random Access Channel, PRACH, of a radio access network.

- 5 A preamble transmitter 2636, wherein a short sequence used to construct the preamble sequence is arranged as cyclic prefix for neighboring short sequences.

A preamble receiver 2741, 1447, arranged to receive radio signals 1405 comprising a preamble sequence, the preamble receiver 2741, 1447 comprising:

- 10 – at least one antenna element 1410 and corresponding radio unit 1406, configured to receive a radio signal, and
- at least one analog to digital converter, ADC, 1407 configured to perform analog to digital conversion of the received radio signal, as well as
- at least one FFT module 1408 arranged to determine a Fast Fourier Transform, of the analog to digital converted signal, and also
- 15 – at least one detector 1428 adapted to detect the preamble sequence based on the determined FFT,

the preamble sequence comprising a concatenation in time of a plurality of short sequences  $s(n)$ , wherein each such short sequence  $s(n)$  having the same time duration as an OFDM symbol used for carrying data traffic in a radio access network of the preamble receiver 2741, 1447, wherein the size of the FFT used for detecting the preamble signal is of the same size as one used for detecting an OFDM symbol carrying data traffic in a radio access network.

A preamble receiver 2741, 1548, arranged to use one FFT hardware resource and FFT configuration both for detecting OFDM symbols carrying data, and also for detecting preamble sequences.

- 25 A preamble receiver 2741, 1849, wherein the preamble receiver comprises a preamble detector arranged to determine a plurality of FFTs from a plurality of FFT windows, and to non-coherently combine the FFT results into a combined received preamble signal.

A preamble receiver 2741, 1548, wherein the preamble receiver comprises a preamble detector arranged to determine a plurality of FFTs from a plurality of FFT windows, and to coherently combine the FFT results into a combined received preamble signal.

A preamble receiver 2741, 1548, wherein a preamble sequence is used for any of initial access,  
5 handover, scheduling request, and resynchronization.

A preamble receiver arranged for beamforming, wherein the beamforming weights are configured to change between FFT windows such that the number of spatial directions for which preamble detection is done is increased.

A preamble receiver, wherein the preamble receiver comprises hardware support for more  
10 than one simultaneous analog beamforming configuration, the preamble receiver being adapted for switching at a first switching rate between spatial directions with one beamforming configuration, and for switching at a second switching rate between spatial directions with another beamforming configuration, the first rate being different from the second rate.

15 A preamble receiver, wherein a single IFFT is applied per beam direction and polarization.

A preamble receiver, arranged to perform simultaneous beam-forming and matched filtering by a comprised joint filter.

A preamble transmitter and receiver system, comprising at least one preamble transmitter according to the present teaching, and at least one preamble receiver according to the present  
20 teaching.

A network node 2740 comprising the preamble receiver 2741 according to the present teaching.

A method performed in a preamble transmitter 2636 for transmitting a preamble sequence, the method comprising the steps of

- generating S11 a short sequence  $s(n)$ , the short sequence having the same time duration as an OFDM symbol used for carrying data traffic in a radio access network of the preamble transmitter 2636,
- constructing S12 a preamble sequence by concatenating a plurality of said short sequences in time, and
- transmitting S13 the constructed preamble sequence as a radio signal to a preamble receiver.

A method performed in a preamble receiver 2741, 1447 for receiving a radio signal and detecting a preamble sequence comprised in the radio signal, the method comprising the steps of

- receiving S21 a radio signal comprising a preamble signal constructed from a plurality of short sequences  $s(n)$  via at least one antenna element 1410 and radio unit 1406, the short sequence  $s(n)$  having the same time duration as an OFDM symbol used for carrying data traffic in a radio access network of the preamble transmitter 2636,
- performing S22 analog to digital conversion of the radio signal by an ADC 1407 comprised in the preamble receiver, and
- determining S23 a Fast Fourier Transform, FFT, 1408 of the analog to digital converted signal, wherein the size of the FFT used for detecting the preamble signal is of the same size as for detecting an OFDM symbol used for carrying data traffic in a radio access network, as well as
- detecting S24 the preamble sequence based on the determined FFT.

## CLAIMS

1. A preamble transmitter (2636) comprising:
  - a short sequence generator (2650) arranged to generate a short sequence  $s(n)$ ,  
and
  - 5       – a preamble sequence generator (2637) adapted to construct a preamble sequence  
by concatenating a plurality of said short sequences  $s(n)$  in time, as well as
  - a transmitter unit (2639a, 2639b) arranged to transmit the generated preamble  
sequence as a radio signal,  
the short sequence  $s(n)$  having the same time duration as an orthogonal frequency  
10       division multiplexing, OFDM, symbol used for carrying data traffic in a radio access  
network of the preamble transmitter (2636).
2. The preamble transmitter (2636) according to claim 1, further arranged to transmit the  
preamble sequence over a Physical Random Access Channel, PRACH, of a radio access  
network.
- 15   3. The preamble transmitter (2636) according to any of claims 1-2, wherein the short  
sequence  $s(n)$  used to construct the preamble sequence is arranged as cyclic prefix for  
neighboring short sequences.
4. The preamble transmitter (2636) according to any of claims 1-3, the short sequence  $s(n)$   
comprising a Zadoff-Chu sequence.
- 20   5. A preamble receiver (2741, 1447) arranged to receive radio signals 1405 comprising a  
preamble sequence, the preamble receiver (2741, 1447) comprising:
  - at least one antenna element (1410) and corresponding radio unit (1406)  
configured to receive a radio signal, and
  - at least one analog to digital converter, ADC, (1407) configured to perform analog  
25       to digital conversion of the received radio signal, as well as
  - at least one fast Fourier transform, FFT, module (1408) arranged to determine a  
Fast Fourier Transform, of the analog to digital converted signal, and also
  - at least one detector (1428) adapted to detect the preamble sequence based on  
the determined FFT,

the preamble sequence comprising a concatenation in time of a plurality of short sequences  $s(n)$ , wherein each such short sequence  $s(n)$  has the same time duration as an orthogonal frequency-division multiplexing, OFDM, symbol used for carrying data traffic in a radio access network of the preamble receiver (2741, 1447), wherein the size of the FFT used for detecting the preamble signal is of the same size as one used for detecting an OFDM symbol carrying data traffic in a radio access network.

- 5 6. The preamble receiver (2741, 1548) according to claim 5, further arranged to use one FFT hardware resource and FFT configuration both for detecting OFDM symbols carrying data, and also for detecting preamble sequences.
- 10 7. The preamble receiver (2741, 1849) according to any of claims 5-6, wherein the preamble receiver comprises a preamble detector arranged to determine a plurality of FFTs from a plurality of FFT windows, and to non-coherently combine the FFT results into a combined received preamble signal.
- 15 8. The preamble receiver (2741, 1548) according to any of claims 5-6, wherein the preamble receiver comprises a preamble detector arranged to determine a plurality of FFTs from a plurality of FFT windows, and to coherently combine the FFT results into a combined received preamble signal.
- 20 9. The preamble receiver (2741, 1548) according to any of claims 5-8, wherein the preamble sequence is used for any of initial access, handover, request for scheduling, and resynchronization.
10. The preamble receiver (2741, 1548) according to any of claims 5-9 arranged for beamforming, wherein the beamforming weights are configured to change between FFT windows such that the number of spatial directions for which preamble detection is done is increased.
- 25 11. The preamble receiver (2741, 1548) according to claim 10, wherein the preamble receiver comprises hardware support for more than one simultaneous analog beamforming configuration, the preamble receiver being adapted for switching at a first switching rate between spatial directions with one beamforming configuration, and for switching at a second switching rate between spatial directions with another beamforming configuration, the first rate being different from the second rate.
- 30

12. The preamble receiver (2741, 1548) according to any of claims 10-11, wherein a single inverse FFT, IFFT, is applied per beam direction and polarization.
13. The preamble receiver (2741, 1548) according to any of claims 10-12, arranged to perform simultaneous beam-forming and matched filtering by a comprised joint filter.
- 5 14. A preamble transmitter and receiver system, comprising at least one preamble transmitter according to any of claims 1-4, and at least one preamble receiver according to any of claims 5-13.
15. A network node (2740) comprising the preamble receiver (2741) according to any of claims 5-13.
- 10 16. A method performed in a preamble transmitter (2636) for transmitting a preamble sequence, the method comprising the steps of
- generating (S11) a short sequence  $s(n)$ , the short sequence having the same time duration as an orthogonal frequency-division multiplexing, OFDM, symbol used for carrying data traffic in a radio access network of the preamble transmitter (2636),
  - 15 - constructing (S12) a preamble sequence by concatenating a plurality of said short sequences in time, and
  - transmitting (S13) the constructed preamble sequence as a radio signal to a preamble receiver.
17. A method performed in a preamble receiver (2741, 1447) for receiving a radio signal and
- 20 detecting a preamble sequence comprised in the radio signal, the method comprising the steps of
- receiving (S21) a radio signal comprising a preamble signal constructed from a plurality of short sequences  $s(n)$  via at least one antenna element (1410) and radio unit (1406), the short sequence  $s(n)$  having the same time duration as an
  - 25 orthogonal frequency-division multiplexing, OFDM, symbol used for carrying data traffic in a radio access network of the preamble transmitter (2636),
  - performing (S22) analog to digital conversion of the radio signal by an ADC (1407) comprised in the preamble receiver, and
  - determining (S23) a fast Fourier transform, FFT, (1408) of the analog to digital
  - 30 converted signal, wherein the size of the FFT used for detecting the preamble

signal is of the same size as for detecting an OFDM symbol used for carrying data traffic in a radio access network, as well as

- detecting (S24) the preamble sequence based on the determined FFT.

18. The method according to claim 17, wherein the step of determining (S23) an FFT further  
5 comprises determining an FFT having a single configuration for detecting OFDM symbols carrying data, and also for detecting preamble sequences.

19. The method according to any of claims 17-18, wherein the step of detecting (S24) comprises determining a plurality of FFTs from a plurality of FFT windows, and also non-coherently combining the FFT results into a combined received preamble signal.

10 20. The method according to any of claims 17-18, wherein the step of detecting (S24) comprises determining a plurality of FFTs from a plurality of FFT windows, and also coherently combining the FFT results into a combined received preamble signal.

15 21. A computer program comprising computer program code which, when executed in a preamble transmitter, causes the preamble transmitter to execute a method according to claim 16.

22. A computer program comprising computer program code which, when executed in a preamble receiver, causes the preamble receiver to execute a method according to any of claims 17-20.



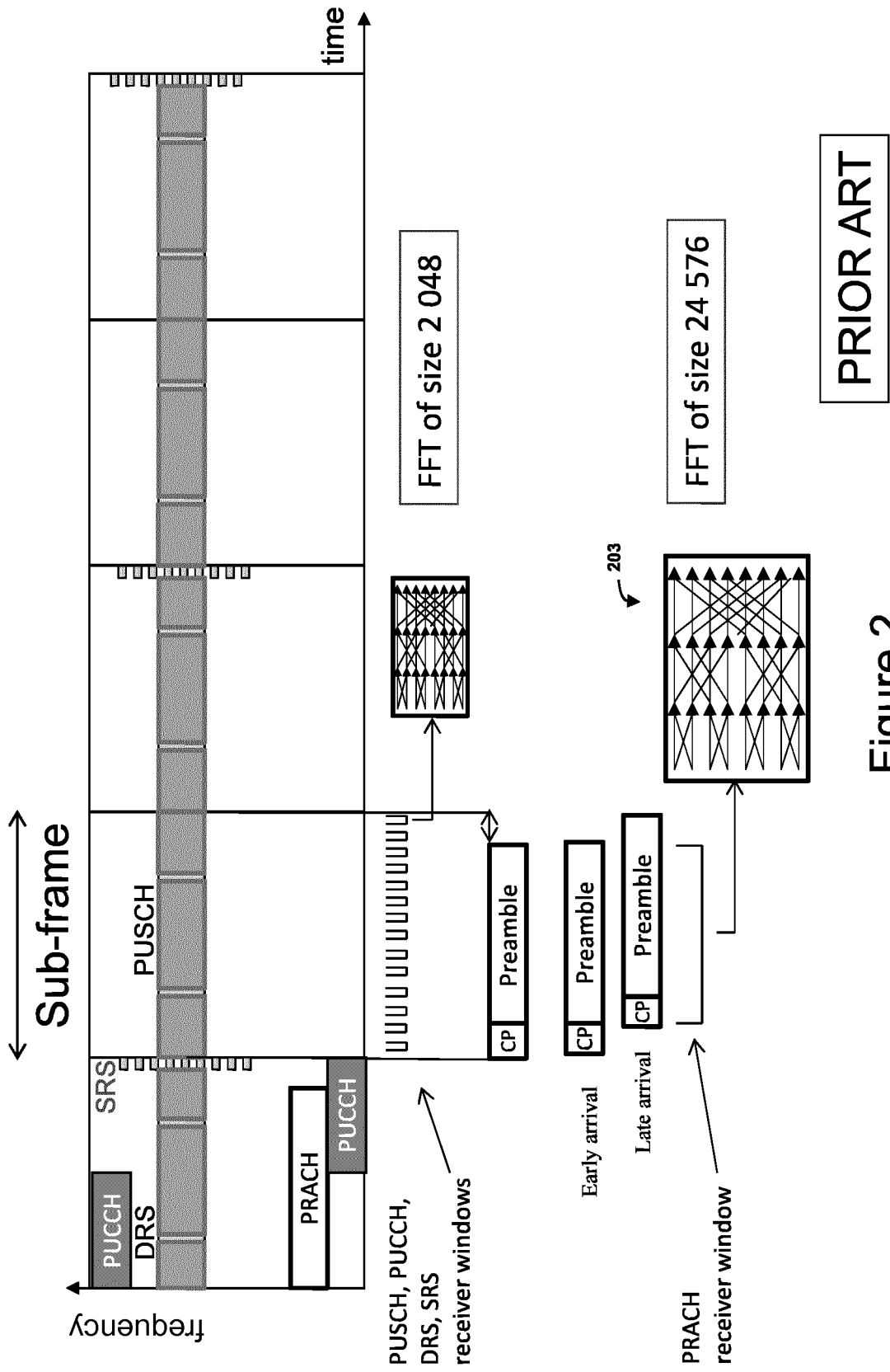

Figure 2

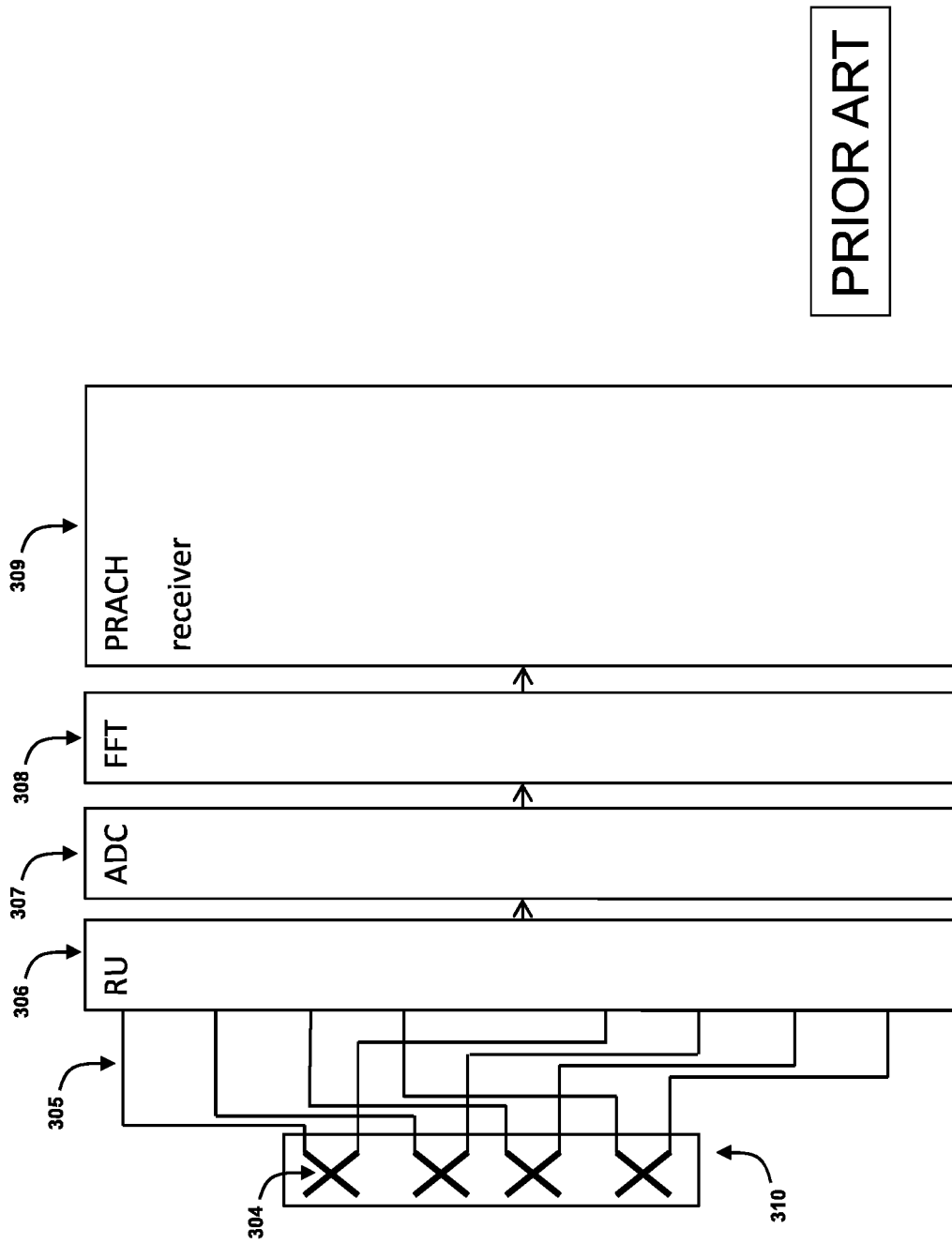
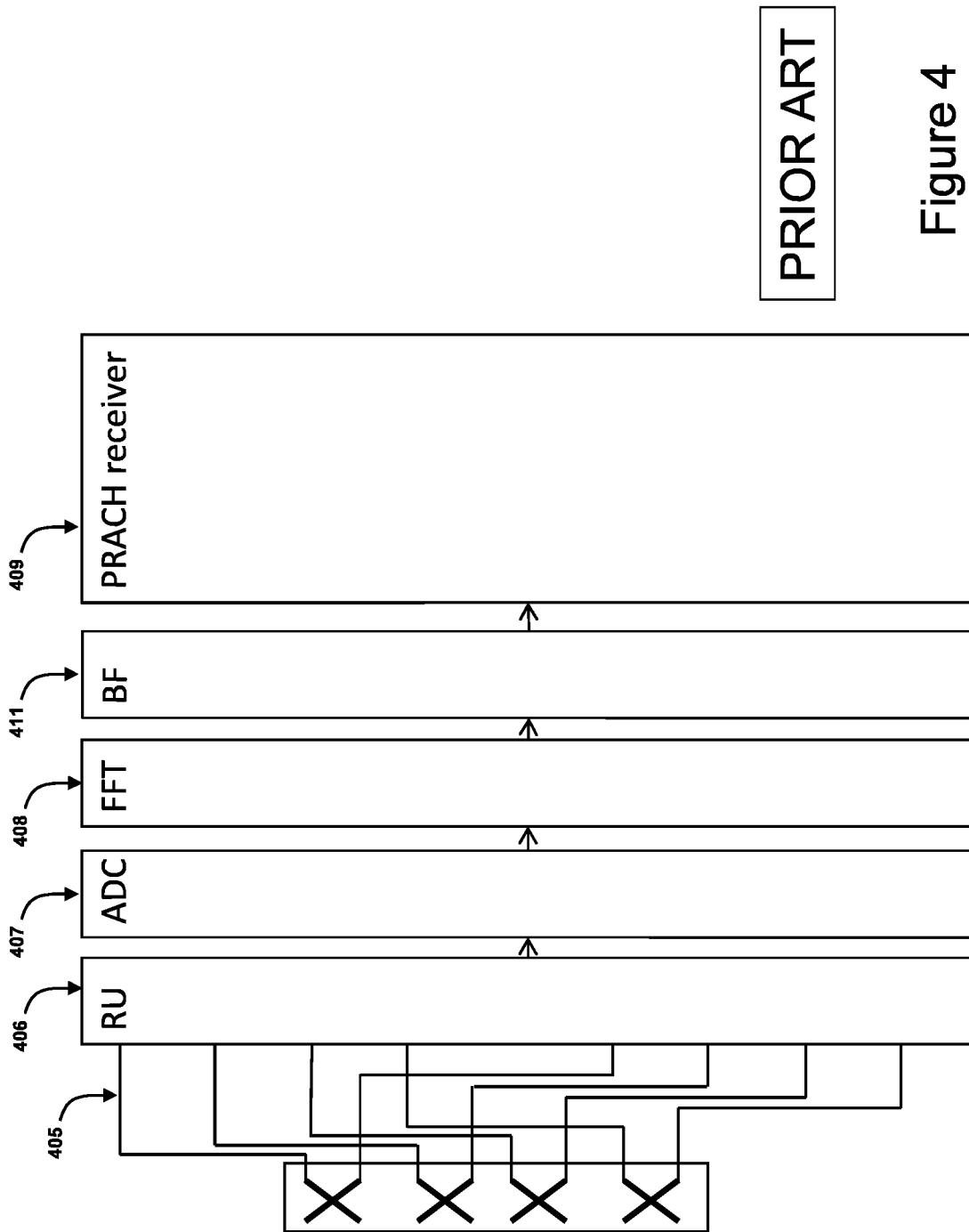
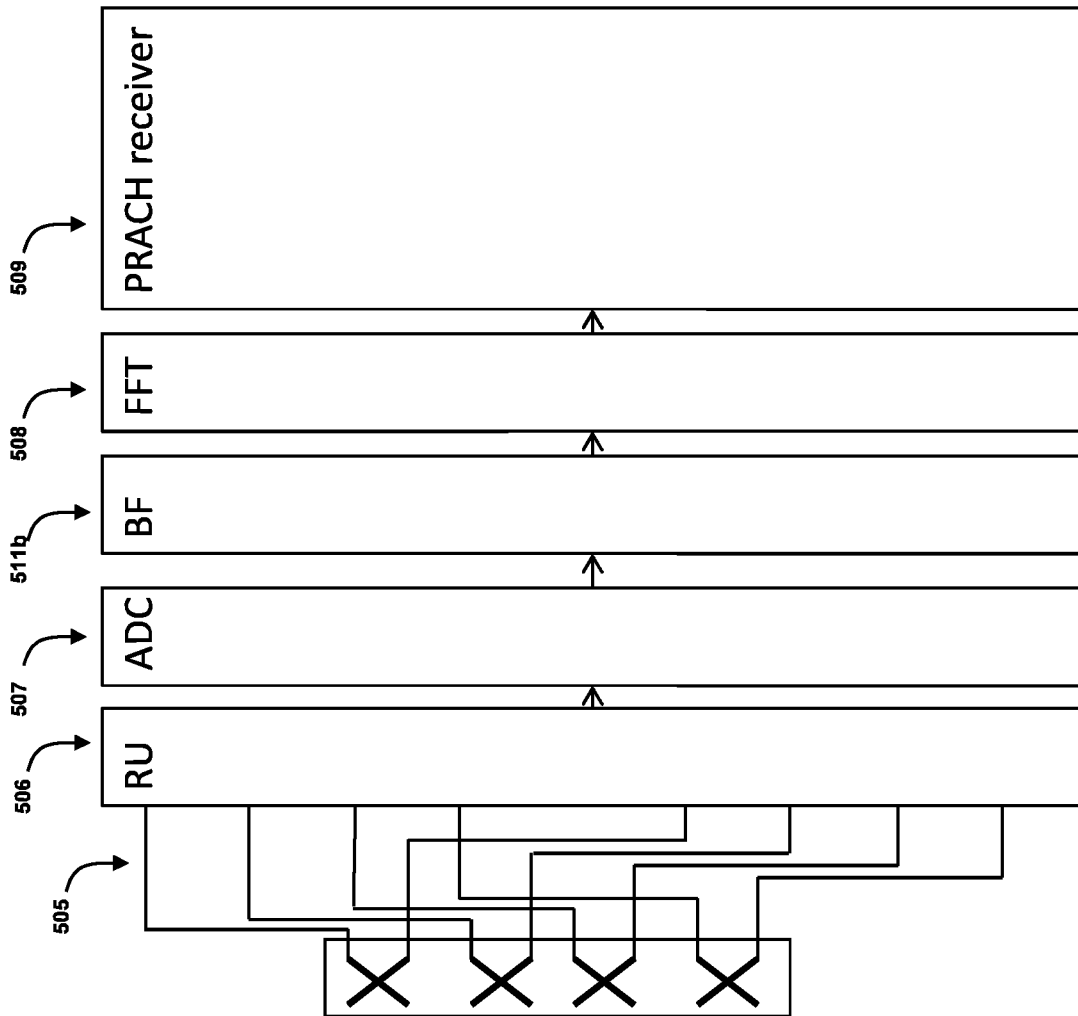

Figure 3





PRIOR ART

Figure 5

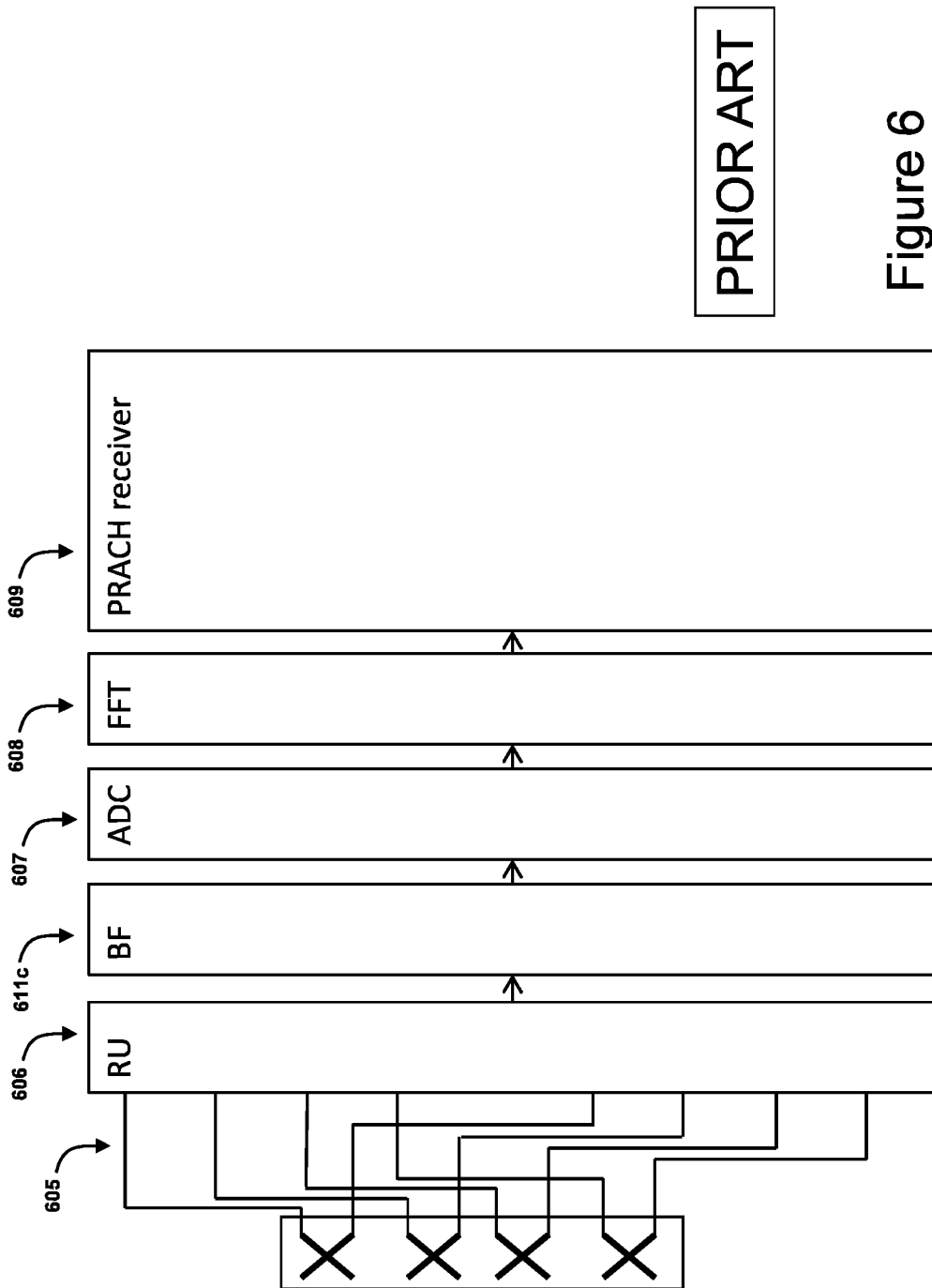

Figure 6



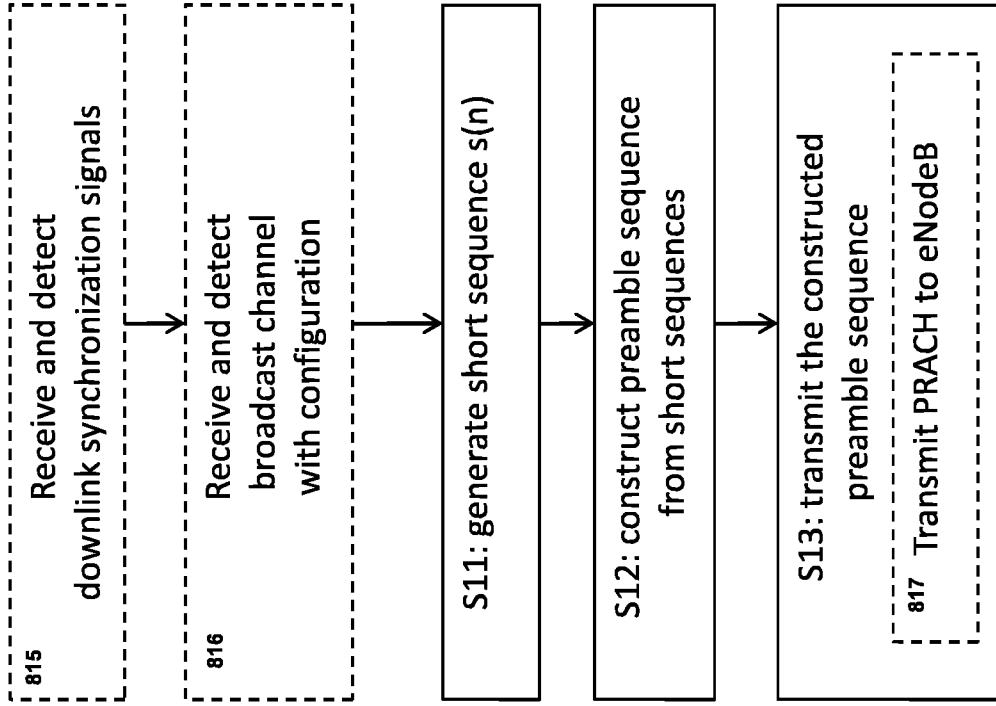

Figure 8b

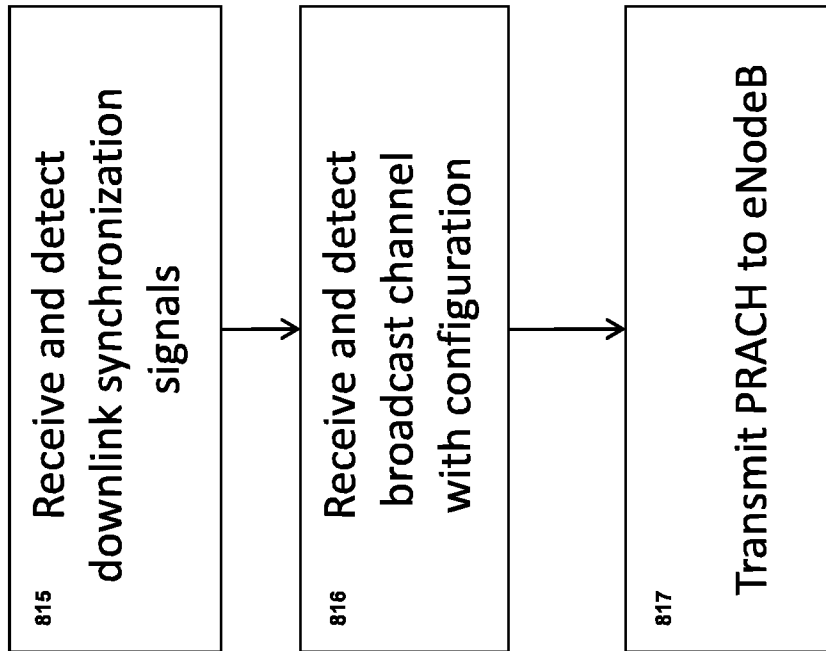

Figure 8a

9/30

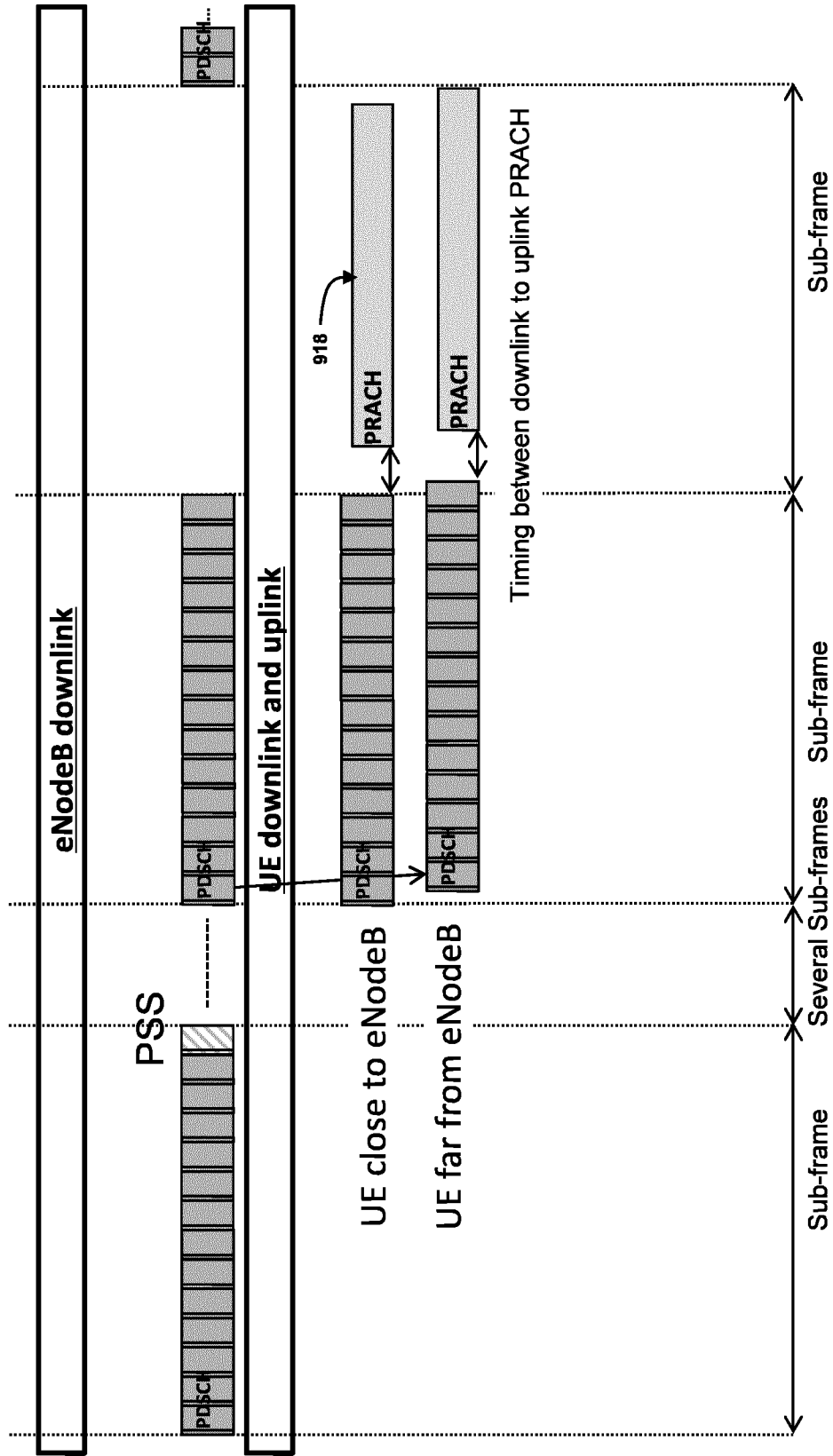

Figure 9

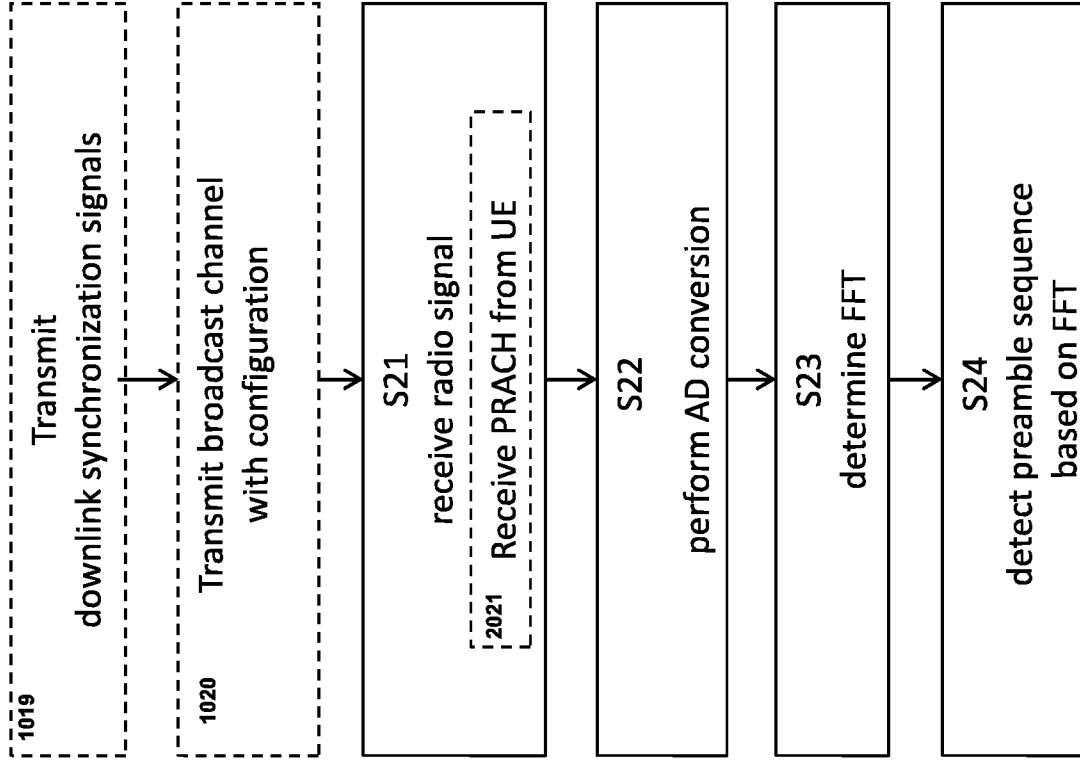

Figure 10b

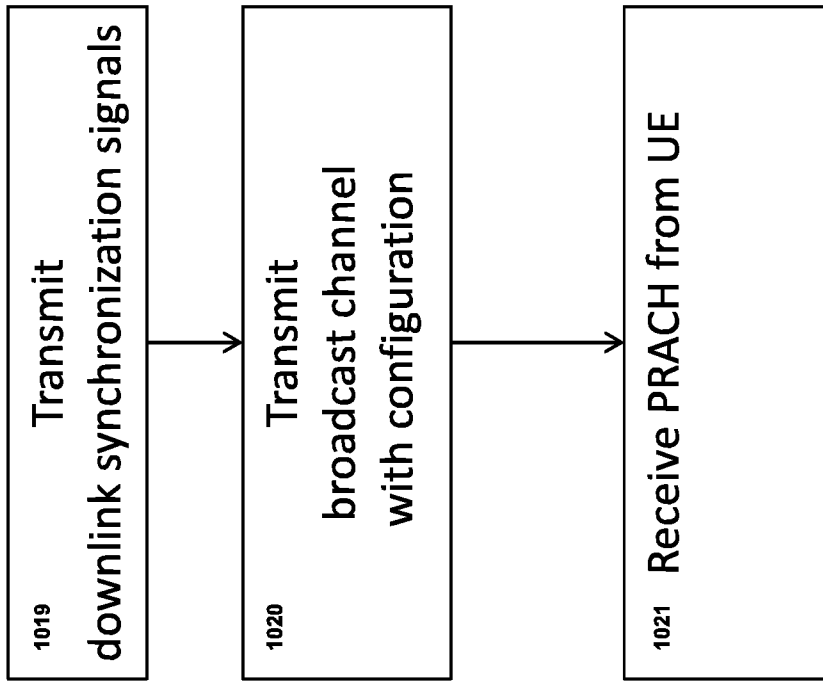
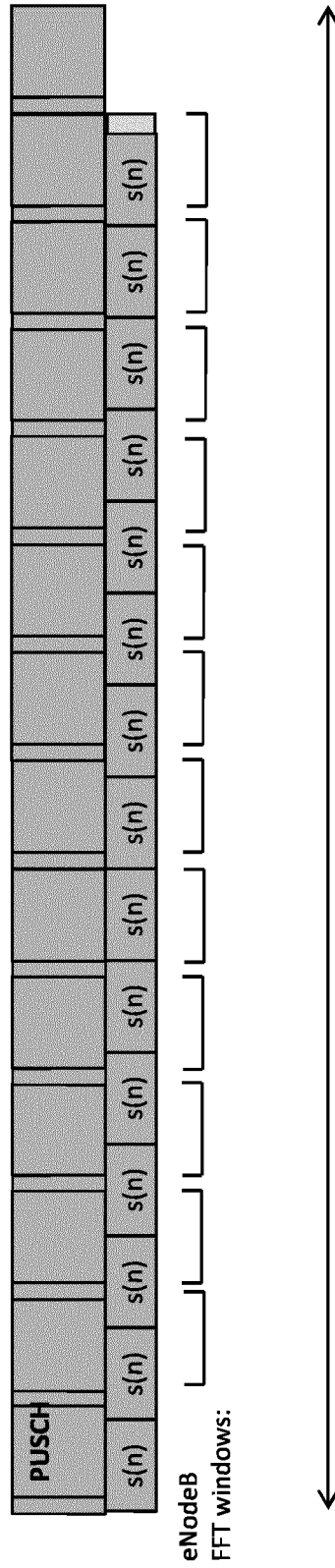

Figure 10a

11/30

1122 ↗



Sub-frame

Figure 11

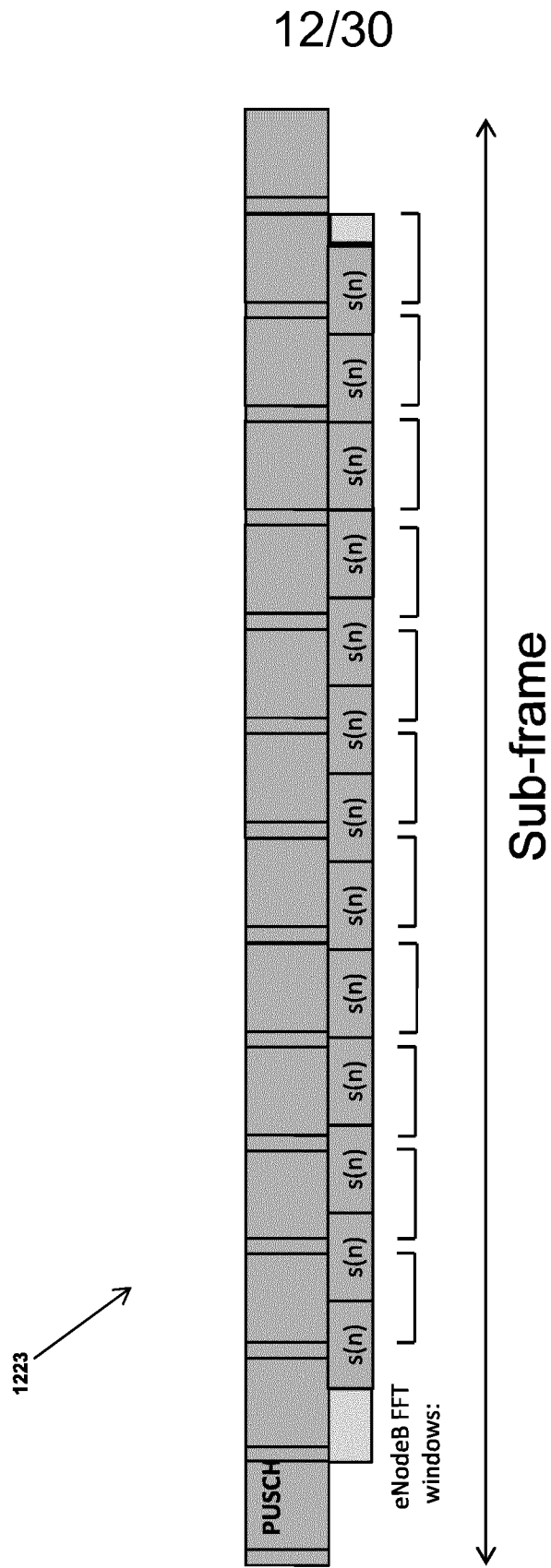
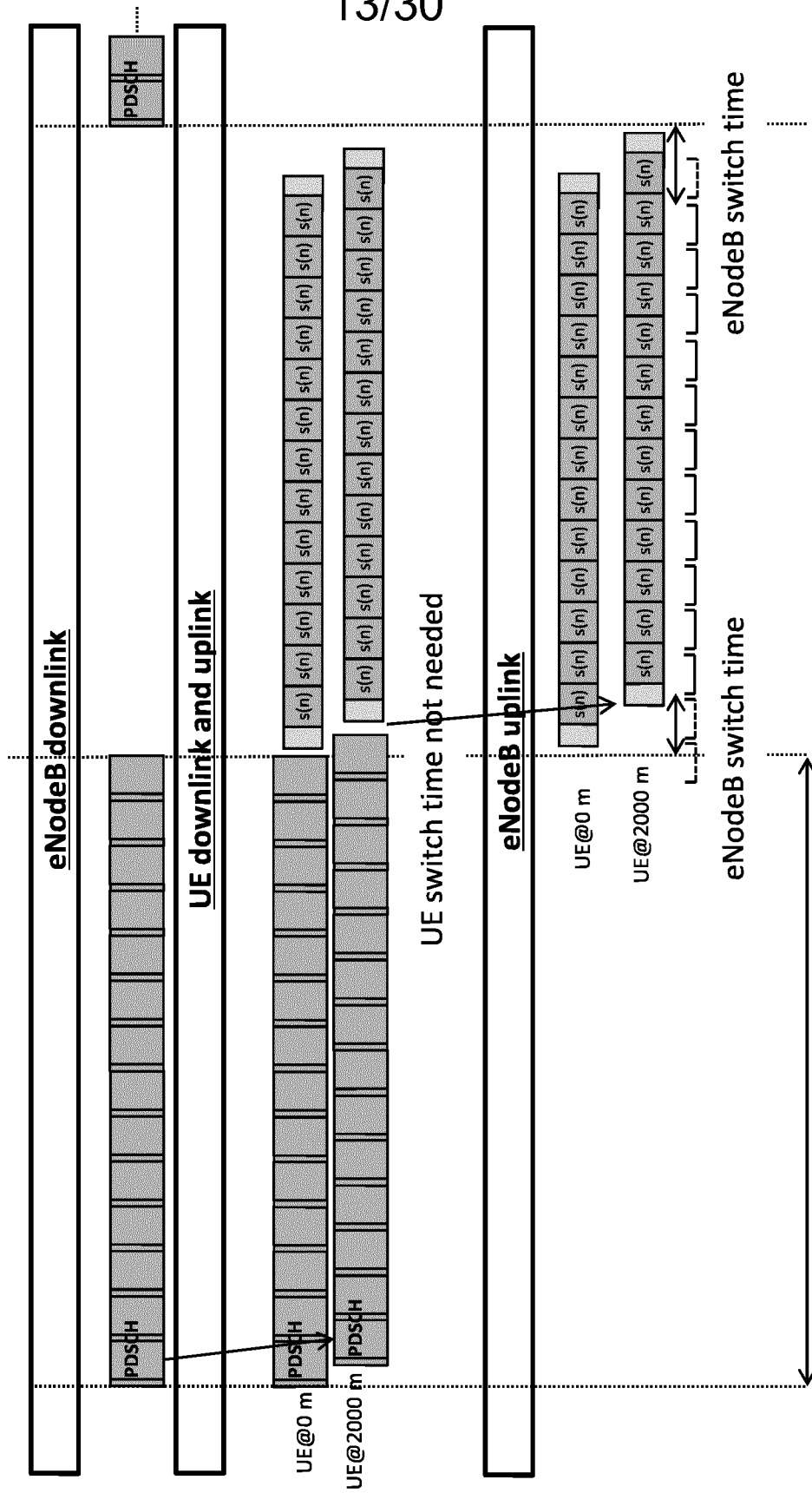

Figure 12



Sub-frame  
Figure 13

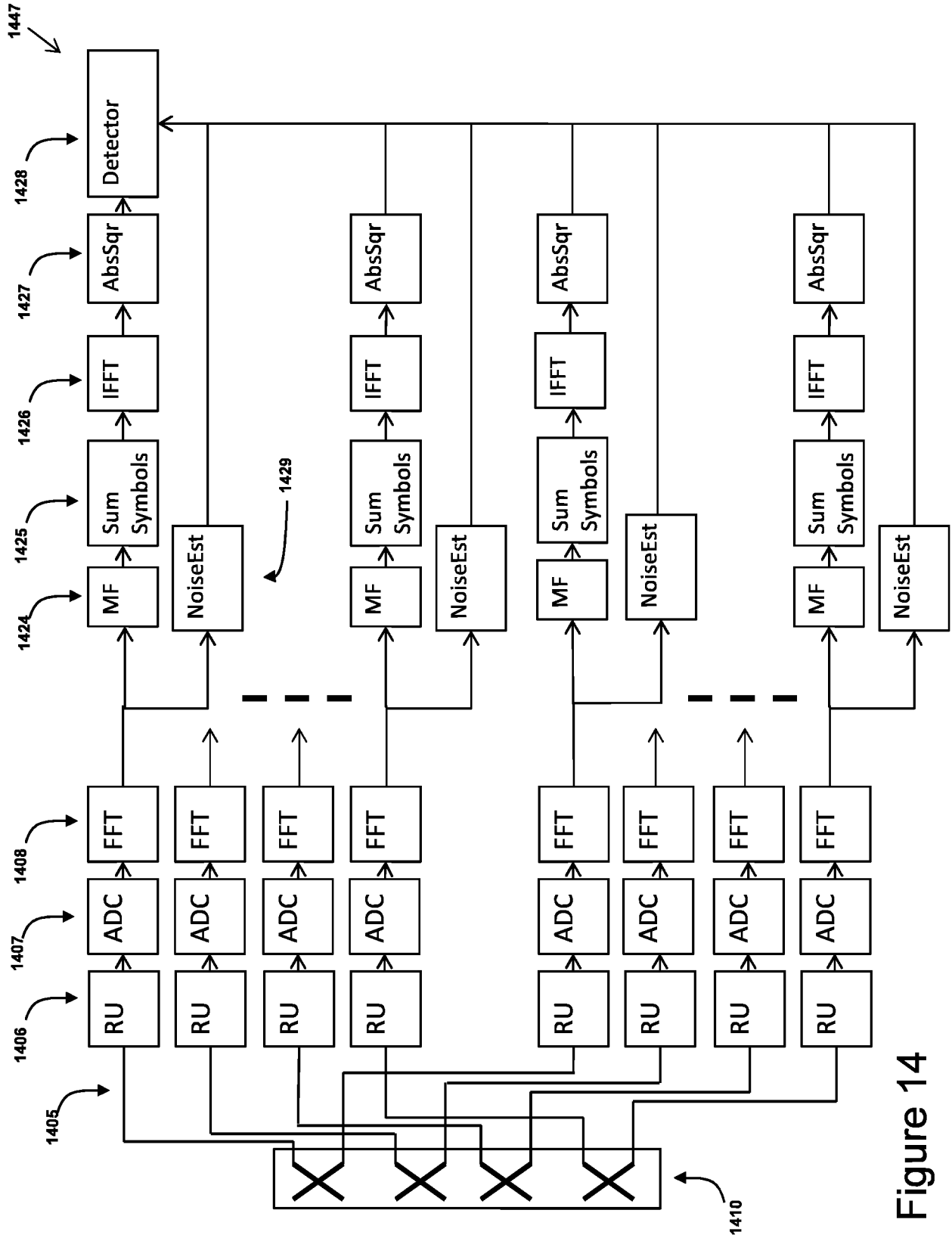

Figure 14



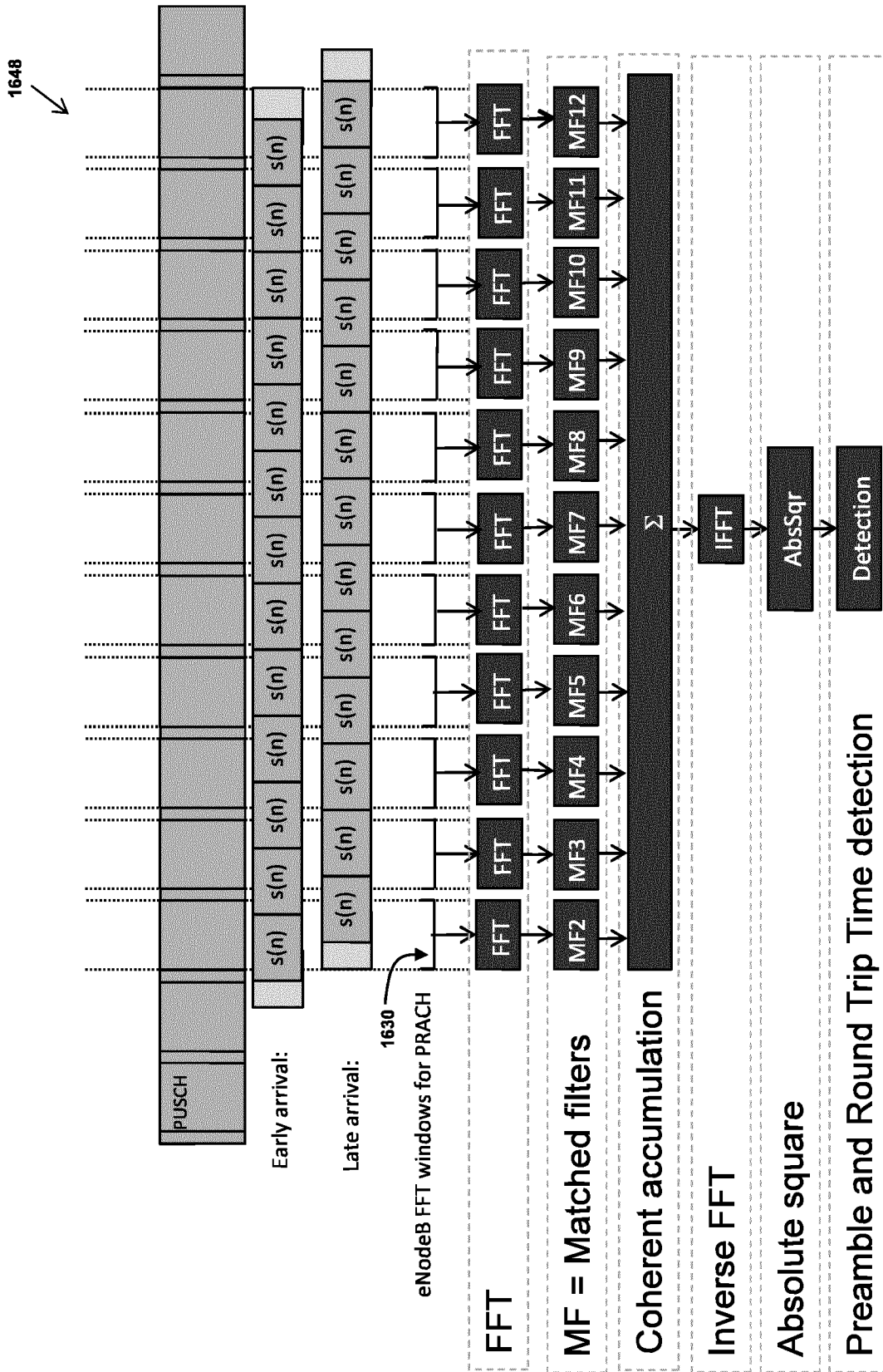

Figure 16

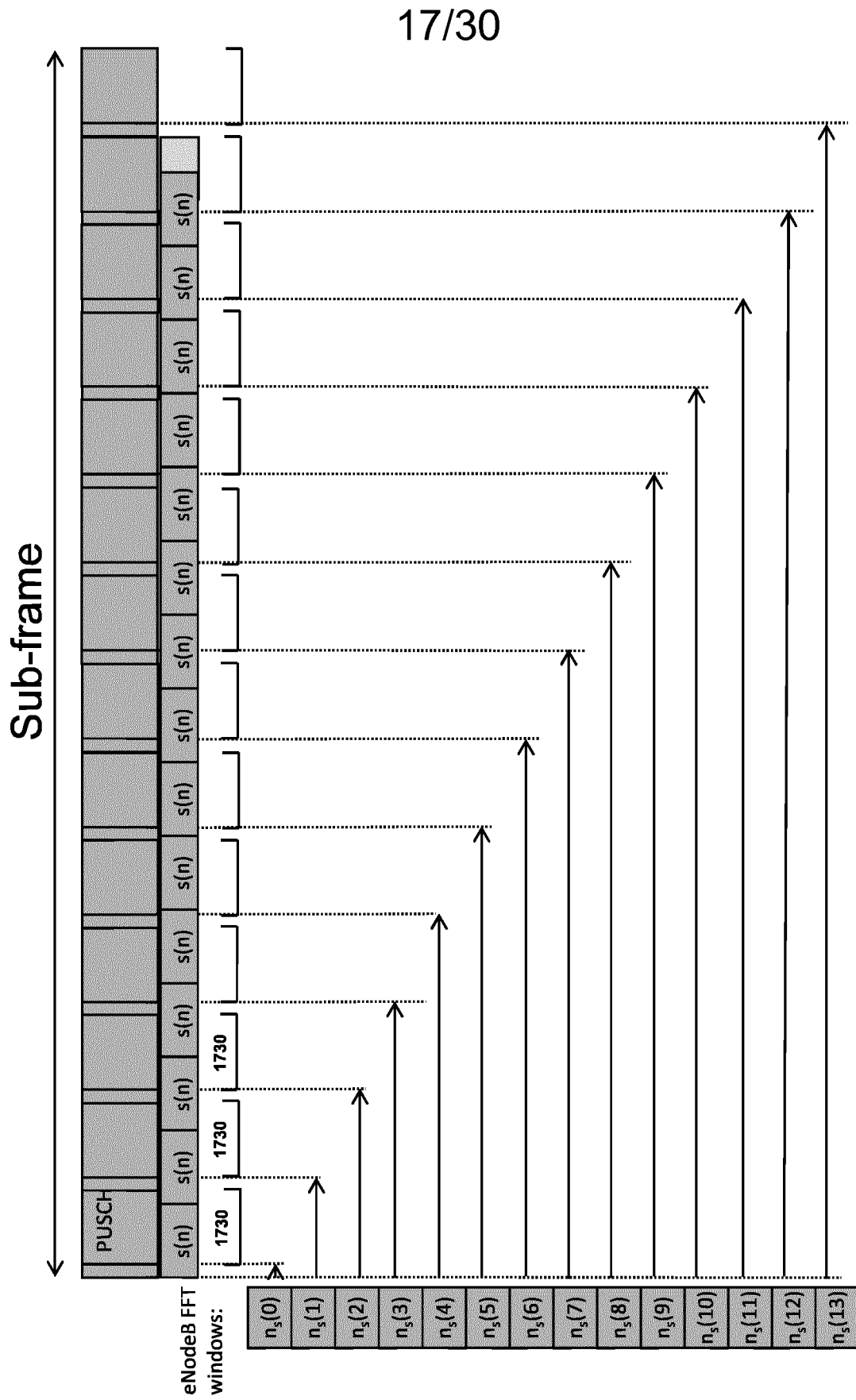

Figure 17

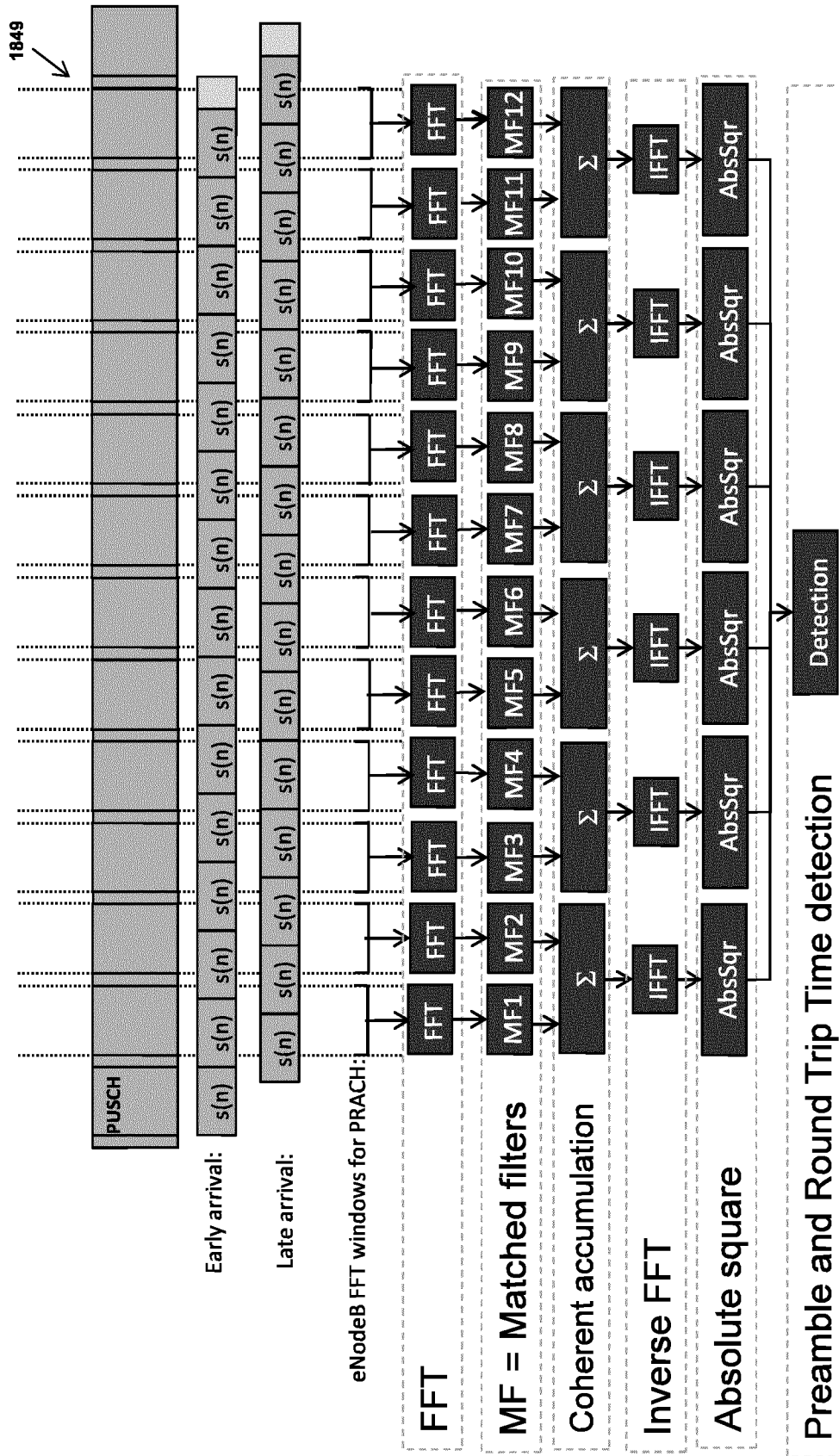

Figure 18

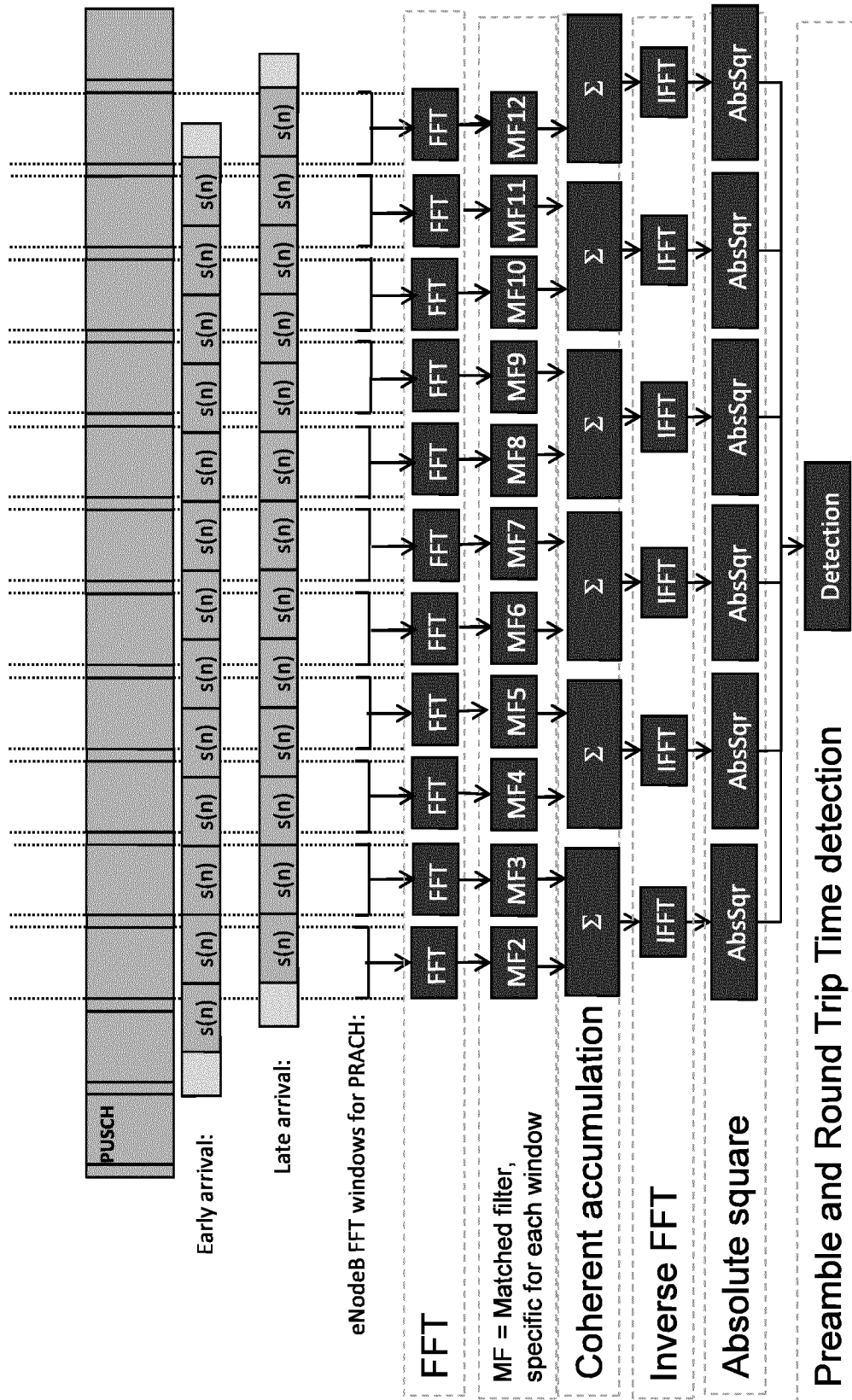

Figure 19

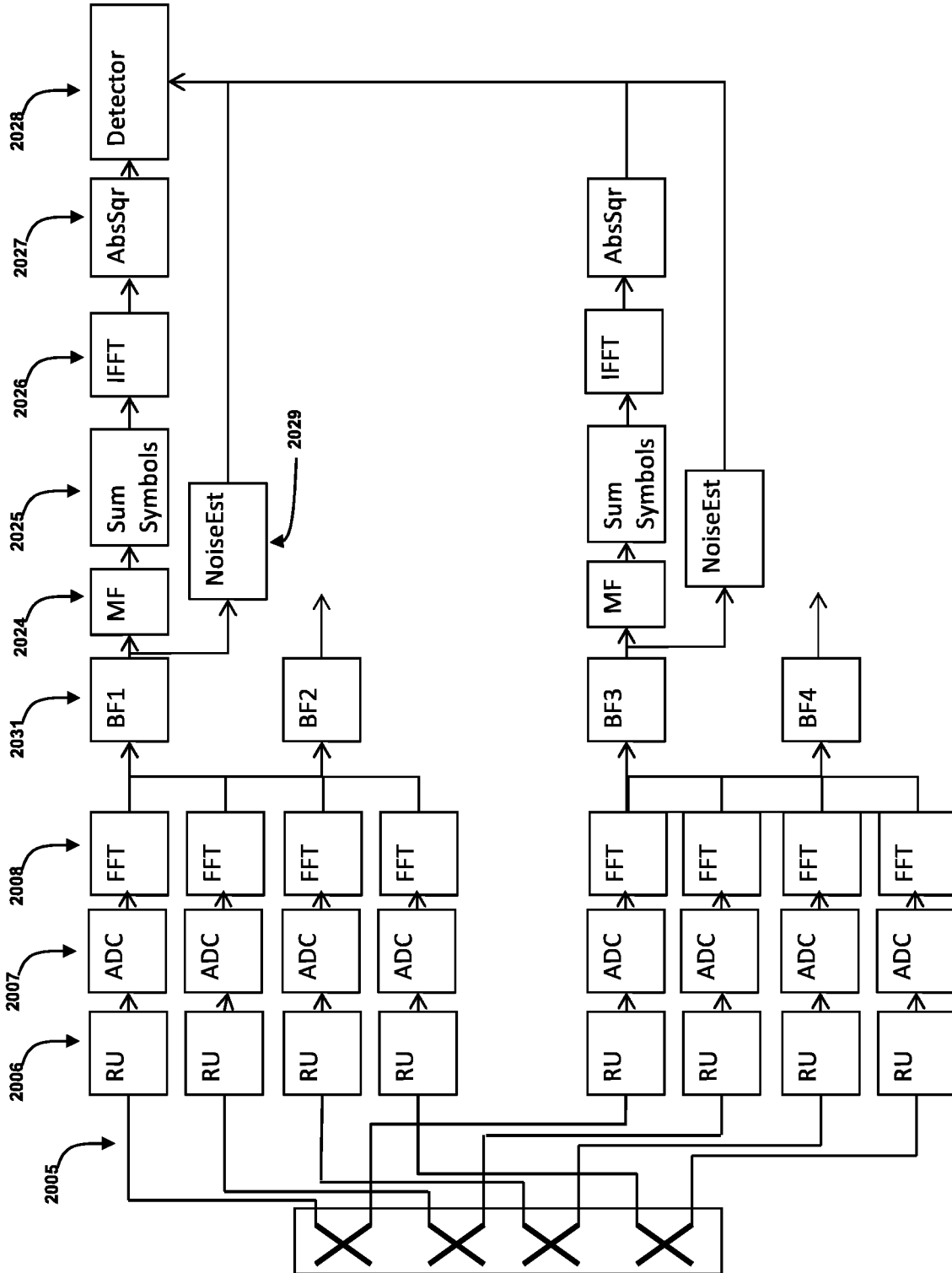

Figure 20

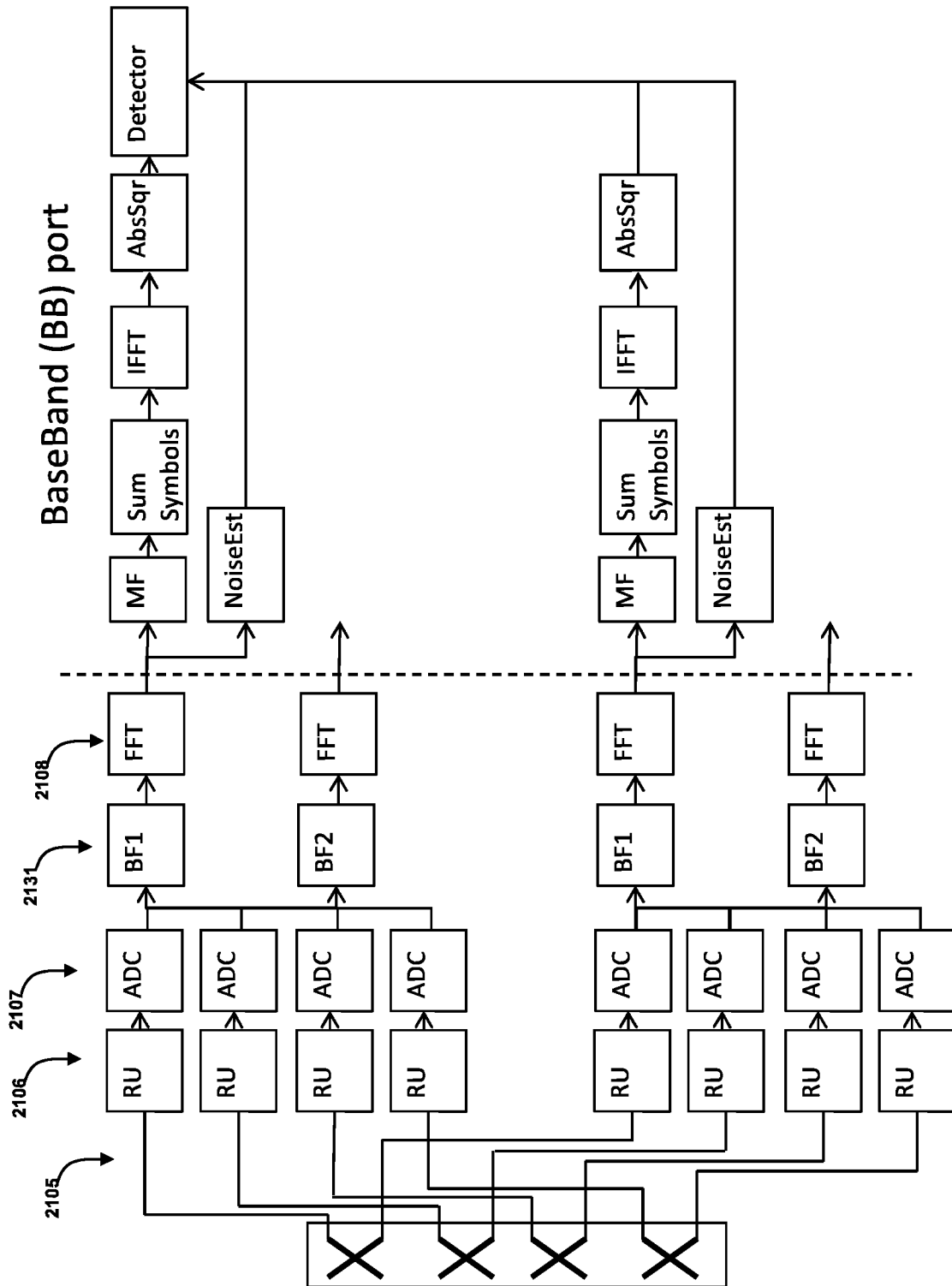

Figure 21

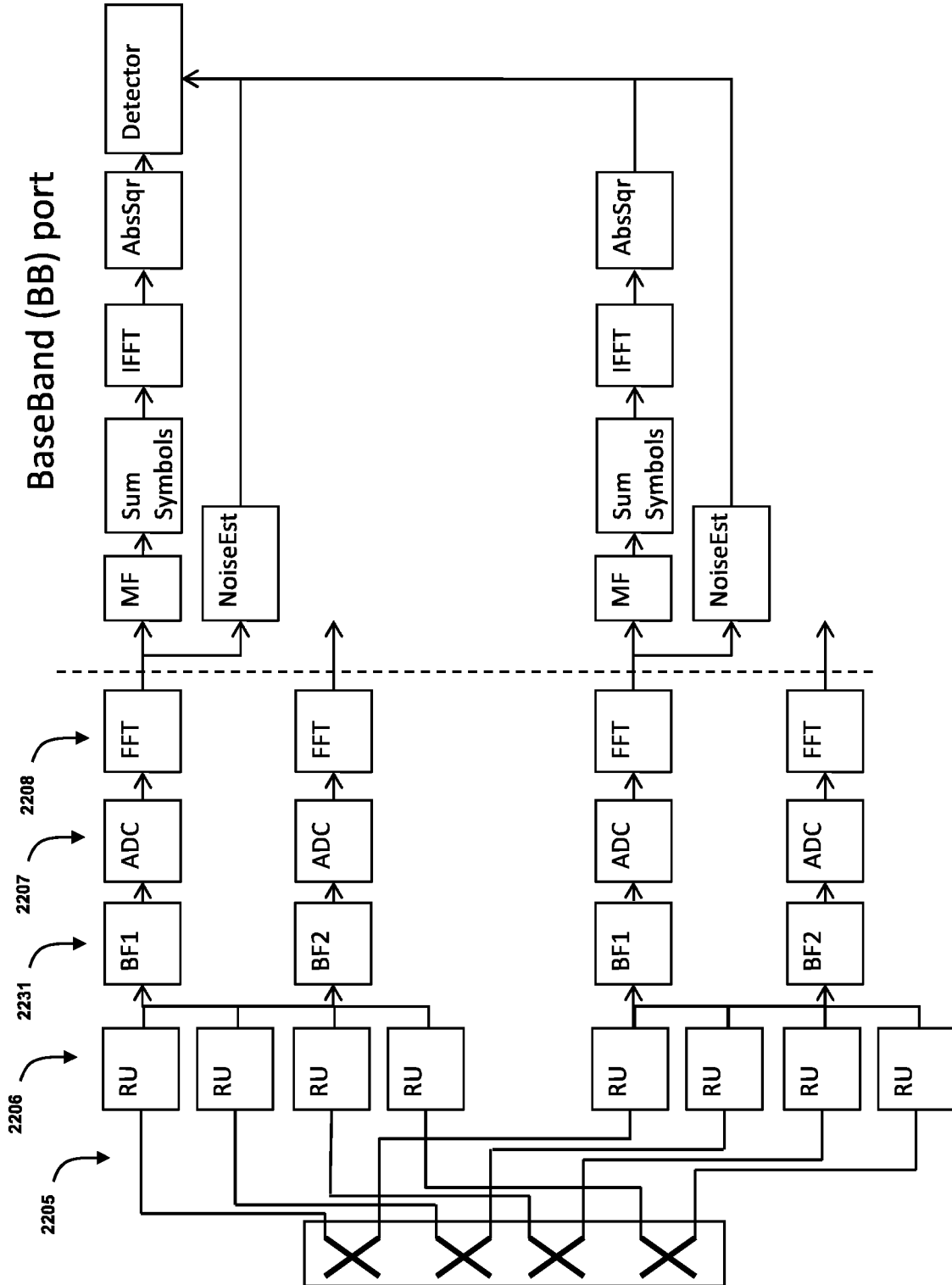

Figure 22

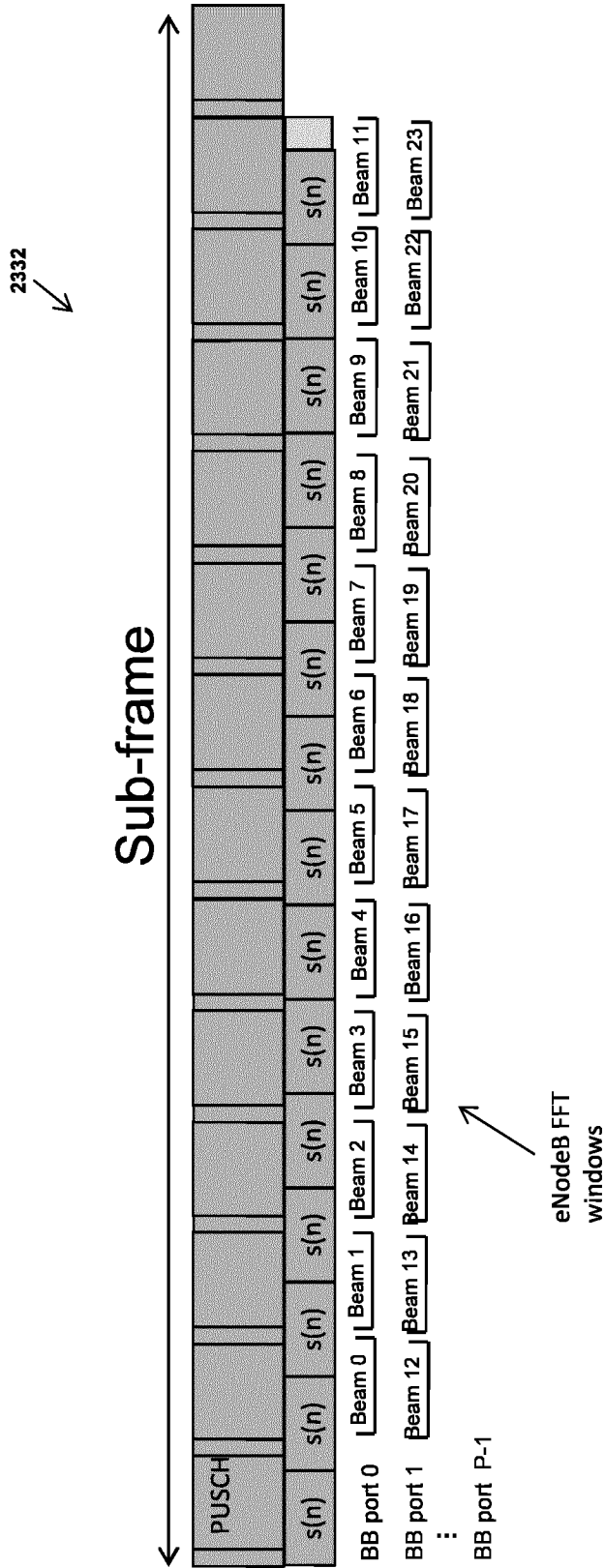

Figure 23

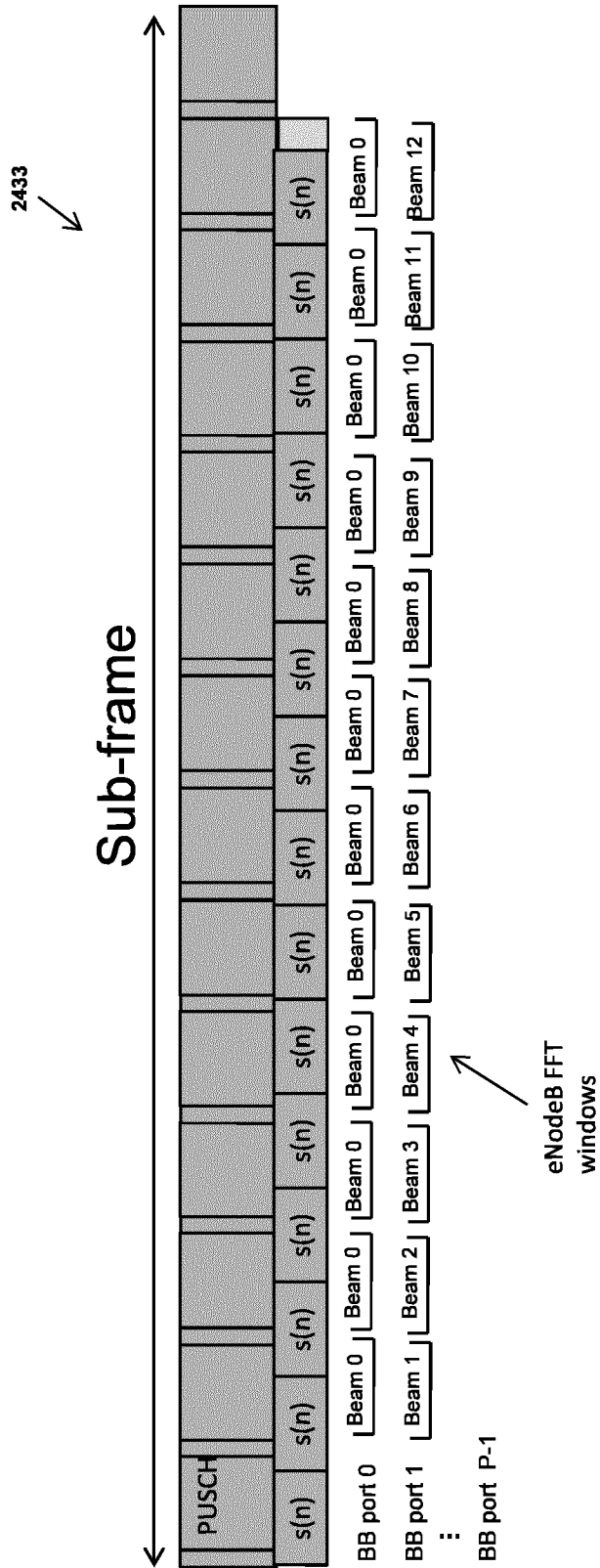

Figure 24

2534

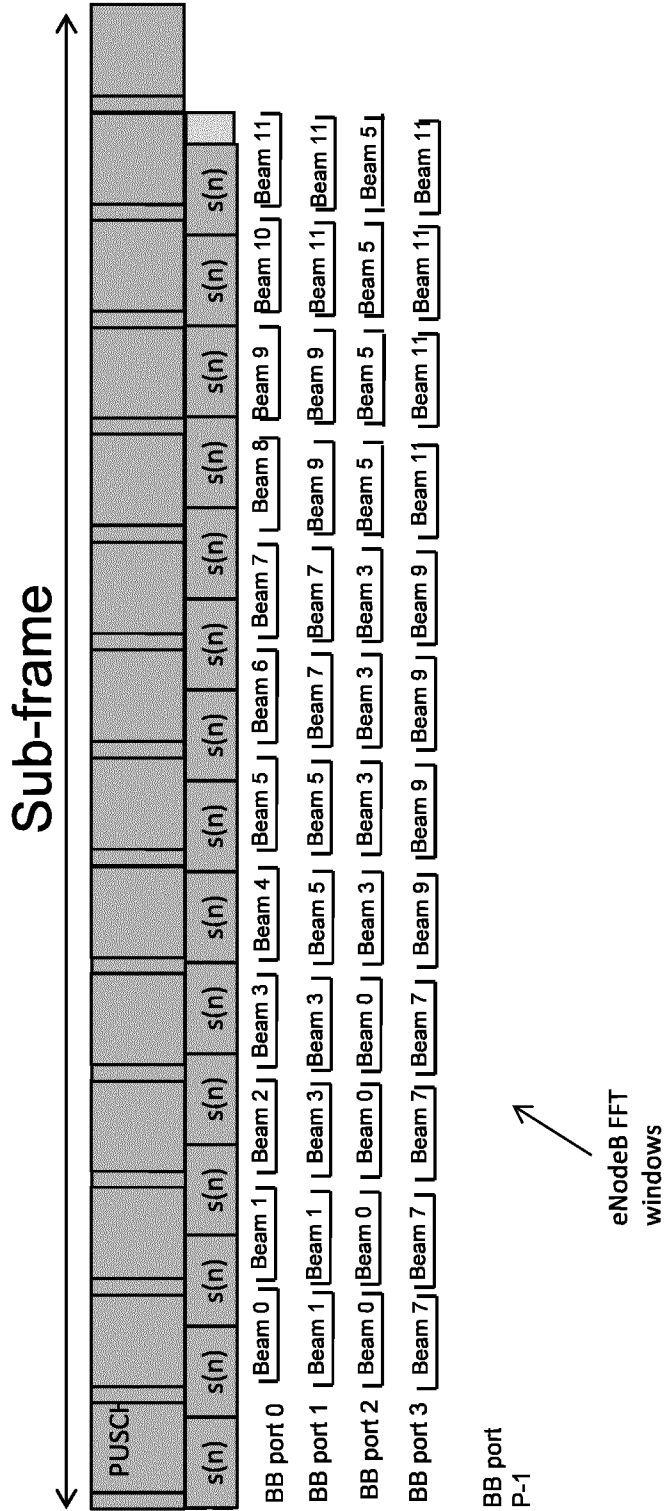

Figure 25

26/30

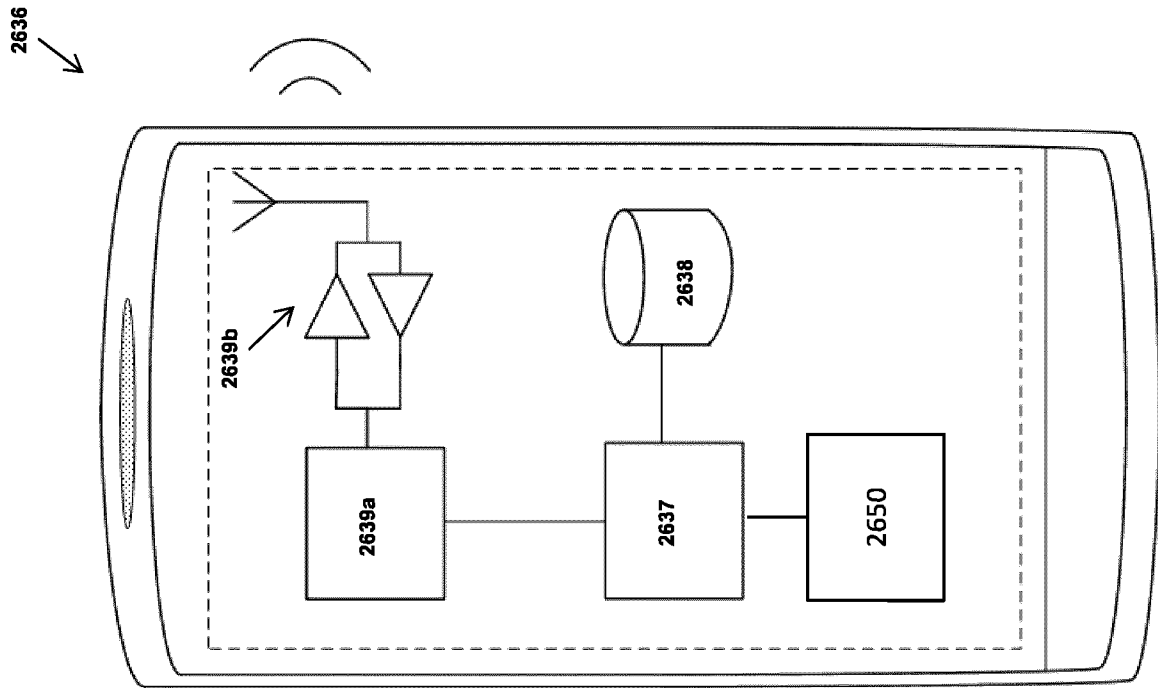

Figure 26

27/30

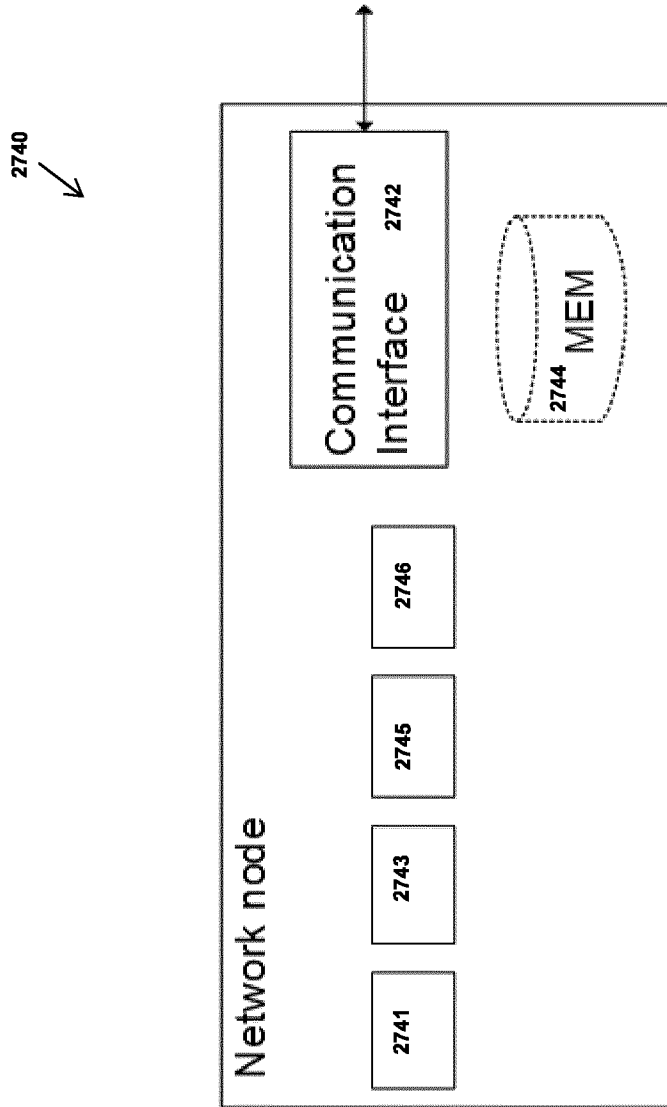

Figure 27

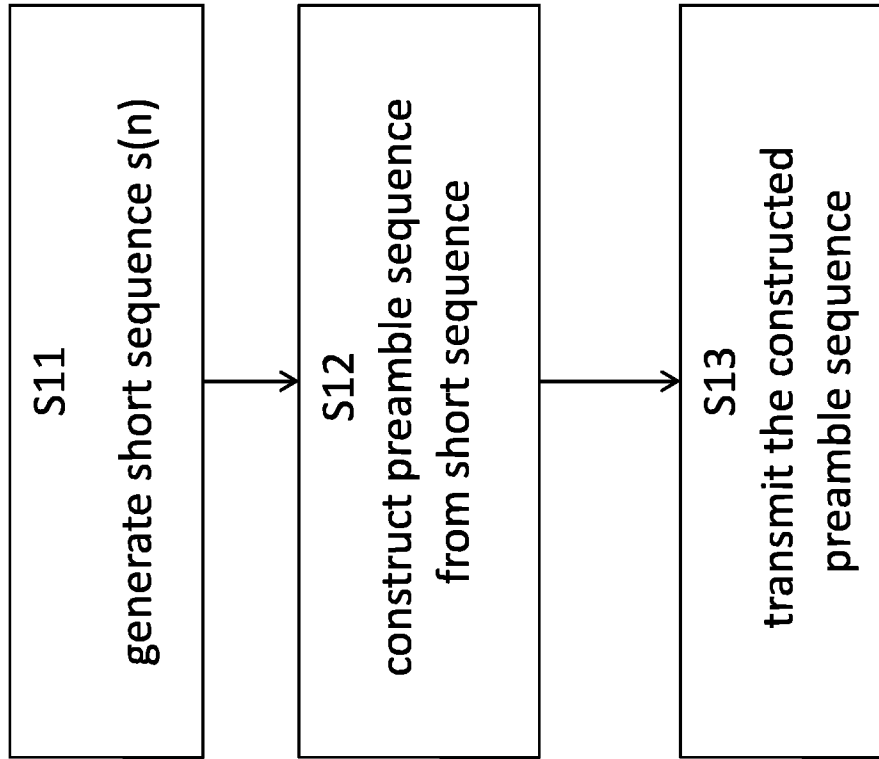

Figure 28

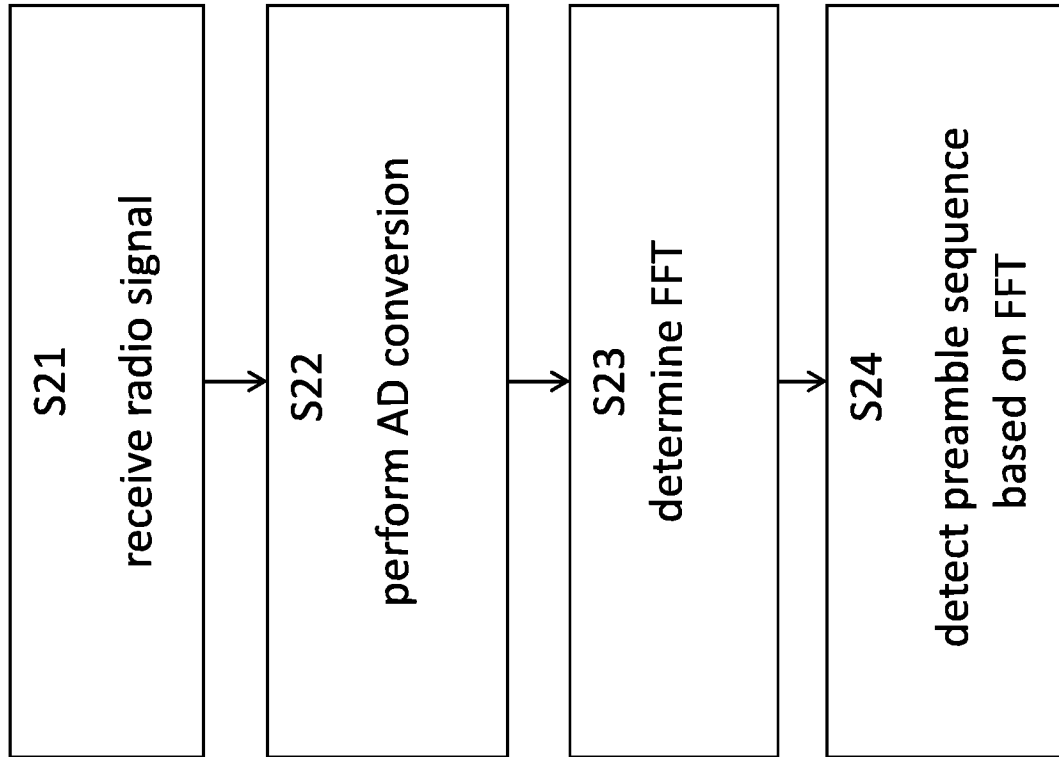

Figure 29

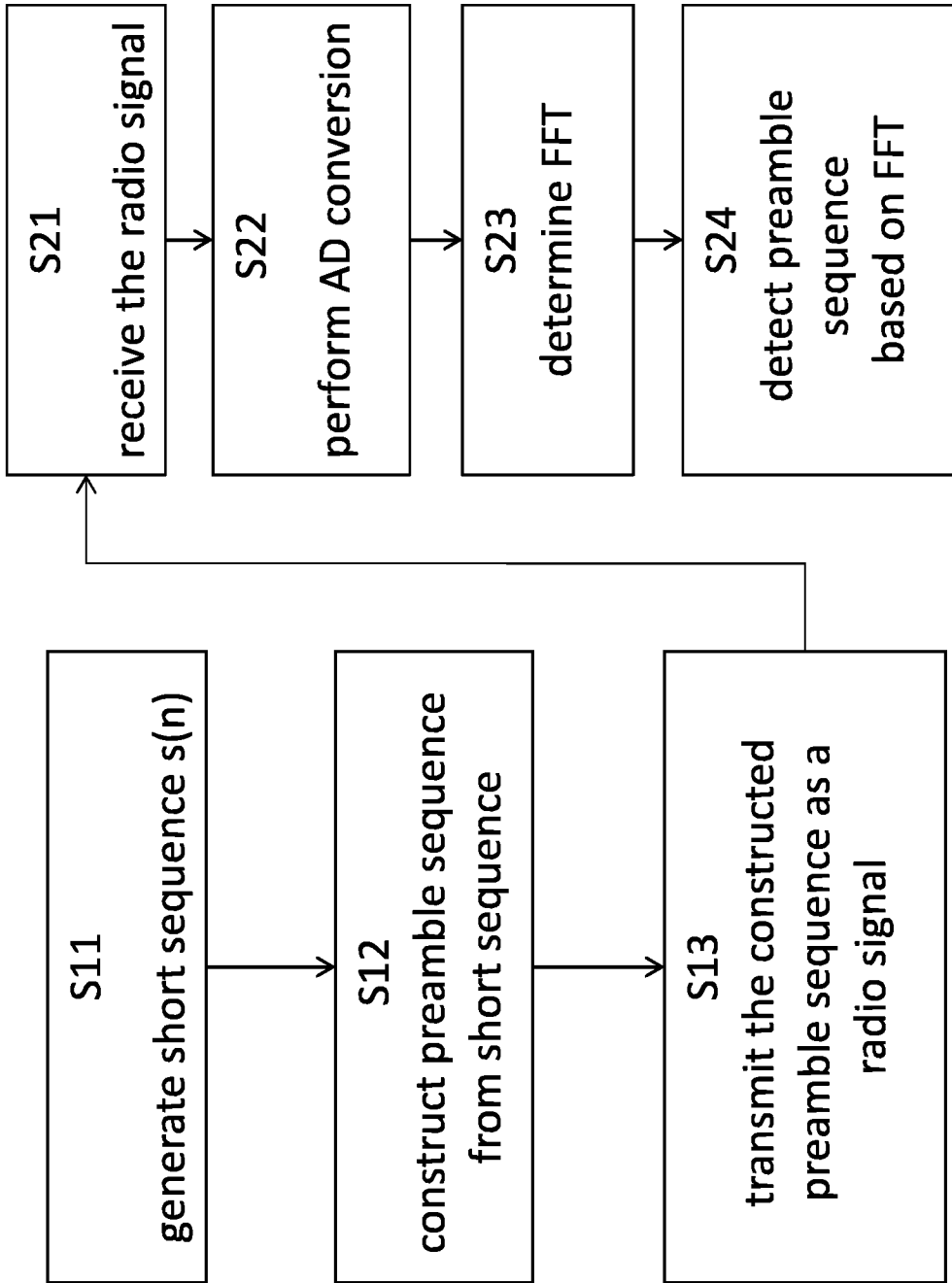

Figure 30

INTERNATIONAL SEARCH REPORT

International application No  
PCT/EP2014/062383

A. CLASSIFICATION OF SUBJECT MATTER  
INV. H04W74/08  
ADD. H04L27/26

According to International Patent Classification (IPC) or to both national classification and IPC

B. FIELDS SEARCHED

Minimum documentation searched (classification system followed by classification symbols)  
H04W H04L

Documentation searched other than minimum documentation to the extent that such documents are included in the fields searched

Electronic data base consulted during the international search (name of data base and, where practicable, search terms used)  
EPO-Internal, WPI Data

C. DOCUMENTS CONSIDERED TO BE RELEVANT

| Category* | Citation of document, with indication, where appropriate, of the relevant passages  | Relevant to claim No.   |
|-----------|---|-------------------------|
| X         | US 2010/172423 A1 (CHRABIEH RABIH [FR])<br>8 July 2010 (2010-07-08)<br>paragraphs [0022] - [0026], [0030];<br>figures 1,2                           | 1-22                    |
| X         | EP 1 274 193 A1 (ERICSSON TELEFON AB L M<br>[SE]) 8 January 2003 (2003-01-08)<br><br>paragraph [0033]   | 1,5,<br>14-17,<br>21,22 |
| X         | WO 2005/088853 A1 (WALTICAL SOLUTIONS INC<br>[US]; LI XIAODONG [US]; LO TITUS [US]; LI<br>KEMIN) 22 September 2005 (2005-09-22)<br>paragraph [0021] | 1,5,<br>14-17,<br>21,22 |
|           | -----<br>-/--   |                         |

Further documents are listed in the continuation of Box C.

See patent family annex.

\* Special categories of cited documents :

- "A" document defining the general state of the art which is not considered to be of particular relevance
- "E" earlier application or patent but published on or after the international filing date
- "L" document which may throw doubts on priority claim(s) or which is cited to establish the publication date of another citation or other special reason (as specified)
- "O" document referring to an oral disclosure, use, exhibition or other means
- "P" document published prior to the international filing date but later than the priority date claimed

"T" later document published after the international filing date or priority date and not in conflict with the application but cited to understand the principle or theory underlying the invention

"X" document of particular relevance; the claimed invention cannot be considered novel or cannot be considered to involve an inventive step when the document is taken alone

"Y" document of particular relevance; the claimed invention cannot be considered to involve an inventive step when the document is combined with one or more other such documents, such combination being obvious to a person skilled in the art

"&" document member of the same patent family

|  |  |
|--|--|
| Date of the actual completion of the international search<br><br>28 October 2014 | Date of mailing of the international search report<br><br>04/11/2014 |
|--|--|

|  |  |
|--|--|
| Name and mailing address of the ISA/<br>European Patent Office, P.B. 5818 Patentlaan 2<br>NL - 2280 HV Rijswijk<br>Tel. (+31-70) 340-2040,<br>Fax: (+31-70) 340-3016 | Authorized officer<br><br>Weinmiller, Jost |
|--|--|

## INTERNATIONAL SEARCH REPORT

International application No  
PCT/EP2014/062383

| C(Continuation). DOCUMENTS CONSIDERED TO BE RELEVANT |  |                       |
|--|--|-----------------------|
| Category*  | Citation of document, with indication, where appropriate, of the relevant passages   | Relevant to claim No. |
| A  | "LTE; Evolved Universal Terrestrial Radio Access (E-UTRA); Physical channels and modulation (3GPP TS 36.211 version 11.3.0 Release 11)",<br>TECHNICAL SPECIFICATION, EUROPEAN TELECOMMUNICATIONS STANDARDS INSTITUTE (ETSI), 650, ROUTE DES LUCIOLES ; F-06921 SOPHIA-ANTIPOLIS ; FRANCE,<br>vol. 3GPP RAN 1, no. V11.3.0,<br>1 July 2013 (2013-07-01), XP014157299,<br>paragraph [5.7.2]<br>----- | 1-22                  |

# INTERNATIONAL SEARCH REPORT

Information on patent family members

International application No

PCT/EP2014/062383

| Patent document cited in search report | Publication date | Patent family member(s) | Publication date |
|--|------------------|-------------------------|------------------|
| US 2010172423                          | A1               | 08-07-2010              | TW 201031138 A   |
|  |                  |                         | US 2010172423 A1 |
|  |                  |                         | WO 2010080856 A1 |
| -----                                  |                  |                         |                  |
| EP 1274193                             | A1               | 08-01-2003              | AT 312444 T      |
|  |                  |                         | AT 377880 T      |
|  |                  |                         | AT 415023 T      |
|  |                  |                         | CN 1522515 A     |
|  |                  |                         | DE 60207860 T2   |
|  |                  |                         | DE 60223422 T2   |
|  |                  |                         | EP 1274193 A1    |
|  |                  |                         | EP 1402677 A1    |
|  |                  |                         | EP 1575207 A2    |
|  |                  |                         | EP 1575208 A2    |
|  |                  |                         | ES 2250682 T3    |
|  |                  |                         | ES 2293423 T3    |
|  |                  |                         | ES 2313153 T3    |
|  |                  |                         | JP 4202912 B2    |
|  |                  |                         | JP 2004534478 A  |
|  |                  |                         | TW 574794 B      |
|  |                  |                         | US 2004180666 A1 |
|  |                  |                         | US 2009034667 A1 |
|  |                  |                         | US 2009052598 A1 |
|  |                  |                         | WO 03005633 A1   |
| -----                                  |                  |                         |                  |
| WO 2005088853                          | A1               | 22-09-2005              | CN 1947348 A     |
|  |                  |                         | KR 20060129004 A |
|  |                  |                         | US 2008305822 A1 |
|  |                  |                         | US 2011292881 A1 |
|  |                  |                         | US 2013250907 A1 |
|  |                  |                         | WO 2005088853 A1 |
| -----                                  |                  |                         |                  |