

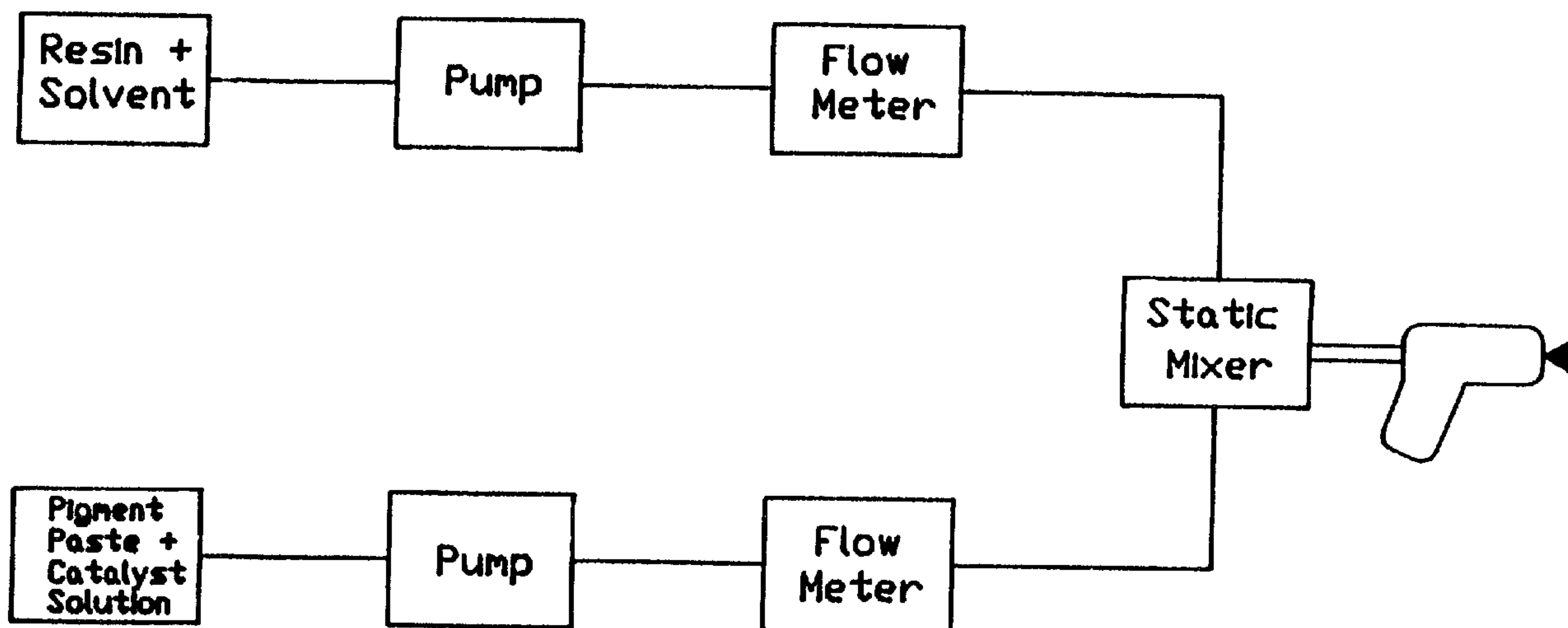

(22) Date de dépôt/Filing Date: 1995/05/04
 (41) Mise à la disp. pub./Open to Public Insp.: 1995/11/26
 (45) Date de délivrance/Issue Date: 2005/02/08
 (30) Priorité/Priority: 1994/05/25 (248,957) US

(51) Cl.Int.⁶/Int.Cl.⁶ B32B 15/08, C23C 14/02
 (72) Inventeurs/Inventors:
 LEIN, MAUREEN M., US;
 EISFELLER, RICHARD C., US;
 POLIQUIN, ALFRED T., US;
 BURNS, MARK, US;
 RUSSELL, JOHN T., US
 (73) Propriétaire/Owner:
 TEXTRON AUTOMOTIVE INTERIORS INC., US
 (74) Agent: MACRAE & CO.

(54) Titre : REVETEMENT CONSTITUE D'UN APPRET ET D'UNE COUCHE DE FOND COMBINES
 (54) Title: COMBINED PRIMER/BASECOAT ISLAND COATING SYSTEM



(57) Abrégé/Abstract:

A process for manufacturing a metallized part comprises the following steps. A part is provided made from a substrate material selected from the group consisting of thermoplastic urethane (TPU), TPU alloys, polyester alloys, nylon, thermoplastic olefins (TPO) and aluminum. A single protective layer (combined primer/basecoat) is spray deposited, flashed and cured over the substrate. Over the combined primer/basecoat layer, a layer of corrosion prone metal is vacuum deposited to form a discontinuous film covering the combined primer/basecoat layer. A layer of clear resinous protective dielectric topcoat is spray deposited and cured to completely cover the layer of vacuum deposited corrosive metal material and fill channels formed in the discontinuous film layer.

COMBINED PRIMER/BASECOAT ISLAND COATING SYSTEM

5

ABSTRACT OF THE DISCLOSURE

A process for manufacturing a metallized part comprises the following steps. A part is provided made from a substrate material selected from the group consisting of thermoplastic urethane (TPU), TPU alloys, polyester alloys, nylon, thermoplastic olefins (TPO) and aluminum. A single protective layer (combined primer/basecoat) is spray deposited, flashed and cured over the substrate. Over the combined primer/basecoat layer, a layer of corrosion prone metal is vacuum deposited to form a discontinuous film covering the combined primer/basecoat layer. A layer of clear resinous protective dielectric topcoat is spray deposited and cured to completely cover the layer of vacuum deposited corrosive metal material and fill channels formed in the discontinuous film layer.

10

15

20

COMBINED PRIMER/BASECOAT ISLAND COATING SYSTEM

TECHNICAL FIELD

This invention pertains to vacuum deposition of amphoteric materials.

BACKGROUND OF THE INVENTION

Vacuum metallizing of plastic and similar dielectric substrates is disclosed in various forms including U.S. Patents:

	2,992,125	Fustier
5	2,993,806	Fisher
	3,118,781	Downing
	3,914,472	Nakanishi
	4,101,698	Dunning
	4,131,530	Blum
10	4,211,822	Kaufman
	4,215,170	Oliva

In addition, two reference books are:

Thin Film Phenomena, Kasturi L. Chopra, Robert E. Kreiger Publishing
15 Company, Huntington, N.Y., 1979. pp. 163-189.

Handbook of Thin Film Technology, Leon I. Maissel and Reinhard Glang,
McGraw-Hill Book Company, New York, N.Y., 1970., pp. 8-32 to 8-43.

U.S. Patents Nos. 4,407,871, 4,431, 711 and 4,713,143, assigned to assignee
of the present invention relate to metallizing of plastic articles and more particularly to the
20 structure and spacing of discrete metal islands used to metallize, rather than a continuous
metal film. The metallizing is performed utilizing the island coating system as detailed in

the aforesaid patents. The system includes generally separate primer and basecoat coating layers, a metallizing layer and a topcoat layer. As disclosed in the above referenced patents, the coating layers contain non-volatile film forming polymers, generally in the range of 10-30%.

The coating layers of the island coating system are spray applied using compressed air to atomize the coatings. All of the coatings have been applied using a high volume, low pressure spray gun with organic solvents, generally at 70-90% by weight, as carriers for the coatings in order to be effectively deposited. If the mixture is not properly sprayed the aesthetic properties of the metallized appearance are not achieved. The material must be even, yet thick enough to cover surface irregularities and yet island formation must occur.

Following deposition, each coating layer is flashed at ambient temperature for twenty minutes to evaporate solvent. The coating layer is then cured for 30 minutes at an elevated temperature.

In addition to proper deposition of the coating layers, the appearance and performance of the commercial product, the conductivity of the metal layer, the corrosion resistance of the metal layer and/or the adhesion of the top coat all relate to the structure and spacing of the islands. The above referenced patents provide further teachings related to nucleation and film growth to the desired island structure and spacing that achieves these ends.

In United States patent 5,290,625, assigned to the assignee of the present invention the above process is applied to aluminum parts. In Canadian Patent No. 2,149,723 assigned to the assignee of the present invention the technology for coating layer deposition is

improved to allow film builds of 1.5 to 2.0 mils eliminating significant coating irregularities.

U.S. Patent No. 4,431,711 shows the significant difference in performance to be obtained with a vacuum metallized flexible plastic product, top coated, where the metal particles are coalesced only to the island state instead of being allowed to coalesce as a thin continuous metallic film across which electrical conductivity is established.

5 The '143 patent adds to the process the step of etching the vacuum deposited material with a solvent which slowly dissolves or removes residual amounts of metal from the channels between the distinct islands. This clears the channels exposing additional bonding surfaces on the substrate for increasing the surface area of adhesion between the substrate and a protective dielectric top coat.

10 Typically, substrate surfaces include surface flaws and molding defects such as blow lines and knit lines. Such flaws can give a "satin" appearance to the product instead of a bright metallic appearance. Such flaws can be covered by the application of a primer layer followed by the basecoat layer as in the present island coating system to provide suitable thickness to correct for such substrate surface flaws. The primer layer provides a smoother
15 surface for the basecoat layer. In general, a coating thickness of

2.0 mils or more for the primer and basecoat layer is usually sufficient to hide the substrate defects. Each individual layer is between 0.5 and 1.2 mils thick, with the combined thickness of at least 2.0 mils and often thicker.

However, having two separately applied layers adds to the cost and weight of the finished product as well as time of production. Two coating layers require two separate spray application steps and two separate flash and curing steps before metallizing. Hence, the cost and time of producing metallized objects is increased. A single thicker layer of either the primer or basecoat layer as formulated in the aforesaid patents did not adequately cover the surface. There was a significant increase of coating defects such as a "satin" appearance and poor appearance quality which can be described as a lack of brightness.

A thicker layer of primer only does not provide the proper surface chemistry upon which to form islands. A thicker layer of basecoat does not provide the necessary black background color such as that provided by the primer which is needed to give good appearance qualities.

An object of the present invention is to eliminate one of the two separate deposition steps of either the primer or basecoat. This would eliminate one set of flash and cure times increasing the efficiency of a production line making the metallized parts by at least 30%. A further object of the present invention is to reduce the cost and weight of a product while retaining the desired bright appearance, i.e. maintaining the aesthetic properties of the metallized appearance. Another object of the

present invention is to reduce waste disposal of organic solvents.

SUMMARY OF THE INVENTION AND ADVANTAGES

5

According to the present invention, a process for manufacturing a metallized part comprises the following steps. A part is provided made from a substrate material selected from the group consisting of thermoplastic urethane (TPU), TPU alloys, polyester alloys, nylon, thermoplastic olefins (TPO) and aluminum. A single protective layer (combined primer/basecoat) is spray deposited, flashed and cured over the substrate. The single protective layer has the following formulation of clear urethane resin 20-40%, black pigment paste 10-30%, solvent blend 40-60%, catalyst solution 0.5-2.0%. Its thickness is from 1.0 to 2.0 mils, with 1.5 mils or more preferred.

20

Over the combined primer/basecoat layer, a layer of corrosion prone metal is vacuum deposited to form a discontinuous film covering the combined primer/basecoat layer. The discontinuous film includes a plurality of discrete islands of the corrosion prone metal material appearing macroscopically as a continuous film of such metal and having a plurality of macroscopically unobservable channels between the islands to maintain the film electrically non-conductive over the combined primer/basecoat layer.

30

A layer of clear resinous protective dielectric topcoat is spray deposited and cured to completely cover the layer of vacuum deposited corrosive metal material and fill the channels. The topcoat bonds the corrosive metal material to the combined primer/basecoat layer throughout the

35

bottom of the channels by an adhesion force greater than two orders of magnitude in strength as compared to the adhesion force between the topcoat and a continuous layer of the corrosion prone metal material.

The process provides metallized parts which have a metallic rather than satin appearance and which are more rapidly and cost-effectively produced by eliminating one application of a layer including flash and cure times as well as reducing wastes.

BRIEF DESCRIPTION OF THE DRAWINGS

Other advantages of the present invention will be readily appreciated as the same becomes better understood by reference to the following detailed description when considered in connection with the accompanying drawings wherein:

FIGURE 1 is a schematic drawing of the two stage metering system for spray deposition of the combined primer/basecoat layer.

DETAILED DESCRIPTION OF THE PREFERRED EMBODIMENT

The present invention provides a process of manufacturing parts that have a metallized appearance and that are faster and more efficient to produce, that is more cost-effective to produce.

The part can be made from a substrate material selected from the group consisting of thermoplastic urethane (TPU), TPU alloys, polyester alloys, nylon, thermoplastic olefins (TPO) and aluminum.

The island coating system is then applied as taught in U.S. Patents Nos. 4,407,871, 4,431,711 and 4,713,143 with the improvements disclosed in the present invention as described hereinbelow.

5 The system includes generally a combined primer/basecoat layer, a metallizing layer and a topcoat layer.

The combined primer/basecoat layer is a suitable polymer with an additional catalyst. In
10 general the combined primer/basecoat layer consists of clear urethane resin 20-40%, black pigment paste 10-30%, solvent blend 40-60%, catalyst solution 0.5-2.0%. It was found that the percent catalyst solution had to be increased in order to provide
15 the proper surface chemistry upon which to form islands. This increase in catalyst overcame the inhibition of the primary chemical reaction of the isocyanate groups and the hydroxyl groups of the urethane resin by the presence of carbon black in
20 the pigment dispersion and the dispersed polymeric material. This is not an issue in the separate primary and basecoat applications since the basecoat does not have pigment.

The catalyst is selected from the metal
25 and amine catalysts such as those known in the art found to be effective in urethane reactions.

The combined primer/basecoat layer has a thickness, as applied, of from 1.0 to 2.0 mils with 1.5 mils being the preferred embodiment. In
30 general it was found using separate primer and basecoat layers that the combined thickness of the two layers had to be equal to or greater than 2.0 mils to provide the proper appearance. By using the combined primer/basecoat layer a weight savings
35 of 30% can be achieved.

The combined primer/basecoat layer is not stable if blended more than one hour prior to spray depositing. If all the ingredients are mixed together they become very viscous and gel. The viscosity of the blend must be stable in order for the spray pumps to provide a constant volume of material, thereby providing consistent film builds. Film builds are critical for both appearance and final physical properties of the part. Therefore, as shown in Figure 1, the mixing is done in two steps. The resin plus solvent mixture is prepared and the pigment paste plus catalyst mixture is prepared. It was found that these two mixtures are stable for more than two days. Immediately before spray depositing, using a two part metering system, the two mixtures are brought together in the proper proportions and spray deposited using a high volume, low pressure application spray technology. Additionally, liquid CO₂ as a supplemental carrier can be used as described in Canadian Patent No. 2,148,723.

The combined primer/basecoat layer is covered by a film layer of vacuum metallized metal material islands having a thickness of 25 to 4,000 angstroms, with 500 to 3,000 as the preferred embodiment, and which are formed in accordance with the process set forth in United States Patent No. 4,431,711 that is owned by the assignee of the present invention. The corrosion prone metal material forms a discontinuous film covering the base layer including a plurality of discrete islands of a corrosion prone metal material appearing macroscopically as a continuous film of such metal and having a plurality of macroscopically unobservable channels between the islands to maintain the film electrically non-conductive over the base layer. The metal can be selected from the group consisting of aluminum, cadmium, cobalt, copper, gallium, indium, iron, nickel, tin and zinc, with indium

being the preferred embodiment.

In the preferred embodiment the present invention includes the steps of etching the valleys of the metal island coating of the '711 patent by the etching steps set forth in United States Patent No. 4,713,143 also owned by the assignee of the present invention. In general a solvent slowly dissolves or removes residual amounts of metal from the channels between the distinct islands. This clears the channels exposing additional bonding surfaces on the substrate for increasing the surface area of adhesion between the substrate and a protective dielectric topcoat. The topcoat layer is formed from a clear resinous protective dielectric plastic material as described in patent 4,431,711 and 4,407,871. The topcoat layer generally comprises a solvent solution of a resin selected from the group consisting of acrylics and urethanes. The topcoat also contains from 0.5 - 3.0% of an UV absorber.

The topcoat layer is spray deposited and cured to completely cover the layer of vacuum deposited corrosive metal material and fill the channels. The topcoat bonds the corrosive metal material to the combined primer/basecoat layer throughout the bottom of the channels by an adhesion force greater than two orders of magnitude in strength as compared to the adhesion force between the topcoat and a continuous layer of the corrosion prone metal material.

In one embodiment, the dielectric topcoat layer can include a dye to provide a colored appearance. In a second embodiment the underlying combined primer/basecoat can include a pigment to provide a colored metallic appearance as disclosed in U.S. Patent No. 5,320,869 assigned to assignee of the present invention.

In another embodiment a further coating consisting of automotive exterior paint can

be applied to the topcoat layer.

The combined primer/basecoat layer and topcoat layer generally have a thickness in the range of 1.0 mil to 2.5 mils and can be the same or different. The combined primer/basecoat layer has a preferred thickness of 1.5 mils or greater which contributes to a non-satin appearance, i.e. an appearance without noticeable surface defects.

5 The process includes a flash step of twenty minutes at ambient temperature followed by curing step after application of each layer. Curing of the combined primer/basecoat layer and topcoat layer is done at 30 minutes at 260°F. By eliminating one layer with its attendant flash and cure times, at least one hour of process time per part is saved, thereby increasing production efficiency by at least 30%.

10 In the preferred embodiment, the step of spray depositing is done while the part is being rotated as described in U.S. Patent No. 5,284,679 assigned to the assignee of the present invention, and at a preferred rotation rate of 2-6 RPM to eliminate satin appearance. In addition a high atomizing air pressure and delivery rate are preferred. Further the step of spray depositing is done while the part is at ambient temperature.

15 Certain parts may require the step of spray depositing to include spot sanding, or a full sanding, prior to application. The step of etching is done while the part is also rotating.

The invention will now be described by way of the following examples with it being understood that other advantages and a more complete understanding of the invention will be apparent to those skilled in the art from the detailed description of the invention hereto.

20

EXAMPLES

Tables 1-3 provide examples of parts that were prepared with the present invention

and tested to meet performance standards. These results are compared to separate primer and basecoat layers as shown in Table 4 and in column 5 of Table 2.

Table 1 presents the results of parts tested to meet General Motors specification 4388. The substrate that was coated is indicated. Table 2 presents the results of parts tested to meet Ford Motor Company specification ESB-M5P10-A while Table 3 lists the results of tests to meet Chrysler Company specification MS-PP11-5.

5

Where parts are the same type they are referred to with the same letter. In Tables 3 and 4, the failures for acid resistance are generally accepted by Chrysler as typical results for this severe test. The abbreviation WIP refers to work in progress.

As the data shows, the combined primer/basecoat performed as well or better than the separate primer and basecoat layers.

5 The invention has been described in an illustrative manner, and it is to be understood that the terminology which has been used is intended to be in the nature of words of description rather than of limitation.

10 Obviously, many modifications and variations of the present invention are possible in light of the above teachings. It is, therefore, to be understood that within the scope of the appended claims, the invention may be practiced otherwise than as specifically described.

TABLE 1

CUSTOMER SPEC GM 4388

<u>TEST METHOD</u>	A POLYESTER ALLOY	B POLYESTER ALLOY	C TPU	D POLYESTER ALLOY
1. ADEQUACY OF CURE GM 9509-P	PASS	PASS	PASS	PASS
2. TAPE ADHESION GM 9071-P MET. A	PASS	PASS	PASS	PASS
3. CROSS CUT TAPE GM 9071-P MET. B	PASS	PASS	PASS	PASS
4. DIME SCRAPE GM 9506-P	N/A	N/A	PASS	PASS
5. KNIFE CROSS HATCH GM 9502-P	PASS-10	PASS-10	PASS-10	PASS-10
6. CHIP RESISTANCE GM 9508-P	PASS-9	PASS-9	PASS-9	PASS-9
7. MOISTURE RESIST. GM 4465-P MET. A	PASS	PASS	PASS	PASS
8. CROSS HATCH TAPE ADHESION GM 9071-P MET. A	PASS	PASS	PASS	PASS
9. CROSS CUT TAPE ADHESION GM 9071-P MET. B	PASS	PASS	PASS	PASS
10. DIME SCRAPE GM 9506-P	N/A	N/A	PASS	PASS
11. KNIFE CROSS HATCH GM 9502-P	PASS-10	PASS-10	PASS-10	PASS-10
12. HEAT RESIST 7 DAYS @ 158°F	PASS	PASS	PASS	PASS
13. +CROSS HATCH ADHESION GM 9071-P	PASS	PASS	PASS	PASS
14. +CROSS CUT ADHESION GM 9071-P	PASS	PASS	PASS	PASS
15. DIME SCRAPE GM 9506-P	N/A	N/A	PASS	PASS
16. KNIFE CROSS GM 9502-P	PASS-10	PASS-10	PASS-10	PASS-10
17. CHIP RESIST GM 9508-P	PASS-9	PASS-9	PASS-9	PASS-9
18. MOISTURE & COLD CYCLE GM 9505-P	PASS	PASS	PASS	PASS
19. +CROSS HATCH ADH GM 9071-P MET. A	PASS	PASS	PASS	PASS
20. +CROSS CUT ADH GM 9071-P MET. B	PASS	PASS	PASS	PASS
21. +DIME SCRAPE GM 9506-P	N/A	N/A	PASS	PASS
22. +KNIFE CROSS HATCH GM 9502-P	PASS-10	PASS-10	PASS-10	PASS-10
23. FUEL RUB DIP GM 9501-P	PASS	FAIL	PASS	PASS
24. FUEL RESIST PUDDLE GM 9500-P	PASS	FAIL	PASS	PASS
25. FLEXIBILITY @ 71.6°F GM 9503-P	PASS-10	PASS-10	PASS-10	PASS-10
26. FLEXIBILITY @ 4.9°F GM 9503 P	PASS-10	PASS-10	PASS-10	PASS-10
27. FLEXIBILITY @ 22°F GM 9503-P	PASS-10	PASS-10	PASS-10	PASS-10
29. WEATHER RESIST SAE J1976	WIP	WIP	WIP	WIP

TABLE 2

CUSTOMER SPEC FORD ESB-M5P10-A

<u>TEST METHOD</u>	<u>A</u>	<u>B</u>	<u>E</u>	<u>D</u>	<u>F</u>
	POLYESTER ALLOY	POLYESTER ALLOY	POLYESTER ALLOY	POLYESTER ALLOY	TPU
3. INITIAL ADH BI 106-01 MET.B	PASS	PASS	PASS	PASS	PASS
4. FLEXIBILITY @73.4°F 13 MM MANDREL	PASS	N/A	N/A	PASS	PASS
5. FLEXIBILITY @ 73.4°F 25 MM MANDREL	N/A	PASS	PASS	N/A	PASS
6. COLD FLEX @ -4.0°F 1/2 X 6 MIN	PASS	PASS	PASS	PASS	PASS
7. TOPCOAT STABILITY 24 H/100°F	PASS	PASS	PASS	PASS	PASS
8. CHIP RESIST SAE J400	PASS-7	PASS-10	PASS-7	PASS-8	PASS
9. WATER RESIST BI 104-01	PASS	PASS	PASS	PASS	PASS
10. HUMIDITY ASTM D2247	PASS	PASS	PASS	PASS	PASS
11. WAX RESIST B4A-19534AA WAX	PASS	PASS	PASS	PASS	PASS
13. ADHESION AFT WAX RESIST BI 106-01	PASS	PASS	PASS	PASS	PASS
14. TAR & ROAD OIL REM. B7A-19520AA	PASS	PASS	PASS	PASS	PASS
16. ADHESION AFT TAR & OIL BI 106-01	PASS	PASS	PASS	PASS	PASS
17. CLEANER WAX & POLISH B8A-19523AA	PASS	PASS	PASS	PASS	PASS
19. ADHESION AFT CLEAN.WAX&POLISH BI 106-01	PASS	PASS	PASS	PASS	PASS
20. LIQUID DETERGENT UNDILUTED	PASS	PASS	PASS	PASS	PASS
22. ADH.AFT LIQ. DETERGENT REST.BI 106-01	PASS	PASS	PASS	PASS	PASS
23. WATER & SPOT SOAP BI 113-01	PASS	PASS	PASS	PASS	PASS
24. GASOLINE REST. 2 TO 5 ML M14J507	PASS	PASS	PASS	PASS	PASS
25. OIL REST. 2 TO 5 ML ROTUNDA MOTOR OIL	PASS	PASS	PASS	PASS	PASS
26. SCUFFING RESIST BN 108-04 HEAD "A"	PASS	PASS	PASS	PASS	PASS
27. WEATHERING RES. FLA. 5° SO. FLA.12 MOS.	WIP	WIP	WIP	WIP	PASS
30. WEATHERING RES. FLA 5° SO. FLA.24 MOS.	WIP	WIP	WIP	WIP	PASS
33. XENON WEO. 1000 HRS. BO 101-01	PASS	PASS	PASS	PASS	WIP
35. FLEXIBILITY @ 73.4°F 25 MM MANDREL	N/A	PASS	PASS	N/A	PASS
36. INITIAL HARDNESS WITHSTAND NORMAL S & H	PASS	PASS	PASS	PASS	N/A

P-641 (DRD)

2148669

TABLE 3

CUSTOMER SPEC CHRYSLER MS-PP11-5

TEST METHOD	F TPU	K POLYESTER ALLOY	C TPU	D POLYESTER ALLOY	E POLYESTER ALLOY
1. INITIAL ADHESION 463PB-15-01 X SCRIBE	PASS	PASS	PASS	PASS	PASS
2. INITIAL ADHESION 463PB-15-01 GRID	PASS	PASS	PASS	PASS	PASS
3. INITIAL ADHESION 463PB-15-01 30 DEGREE	PASS	PASS	PASS	PASS	PASS
4. INITIAL ADHESION 463PB-15-01 90 DEGREE	PASS	PASS	PASS	PASS	PASS
5. ADHESION BEFORE HUMIDITY 463PB-9-01	PASS	PASS	PASS	PASS	PASS
6. HUMIDITY 463PB-9-01	PASS	PASS	PASS	PASS	PASS
7. ADHESION AFTER HUMIDITY 463-PB-9-01	PASS	PASS	PASS	PASS	PASS
8. SALT SPRAY 463-PB-10-01 240 HRS.	N/A	N/A	N/A	PASS	PASS
9. FADEOMETER 463-PB-17-01 240 HRS.FAD-R	PASS	PASS	PASS	PASS	PASS
10. WEATHEROMETER 463-PB-16-02 240 HRS XW	PASS	N/A	PASS	PASS	PASS
11. QUV ASTM G53-84 1000 HRS.	PASS	N/A	N/A	PASS	PASS
12. FLORIDA 12 MO. 463-PB-34-01 5' SO	WIP	FAIL	N/A	FAIL	FAIL
13. FLORIDA 24 MO. 463-PB-34-01 5' SO	WIP	N/A	N/A	WIP	WIP
14. FLORIDA 36 MO. 463-PB-34-01 5' SO	WIP	N/A	N/A	WIP	WIP
15. CYCLING 15 CYCLES 463-PB-22-01 MET.IV	PASS	PASS	PASS	PASS	PASS
16. MAR RESISTANCE 463-PB-43-01	PASS	PASS	PASS	PASS	PASS
17. SOAP & WATER RESISTANCE 463-PB-8-01	PASS	FAIL	FAIL	PASS	FAIL
18. SOLVENT WIPE 463-PB-7-01 NAPHTHA MS 1316	PASS	PASS	PASS	PASS	PASS
19. ACID RESIST 463-PB-6-01 0.5% HCL	FAIL	FAIL	FAIL	FAIL	FAIL
20. ACID RESIST 463-PB-6-01 1.0% HCL	FAIL	FAIL	FAIL	FAIL	FAIL
21. ACID RESIST 463-PB-6-01 2.0% HCL	FAIL	FAIL	FAIL	FAIL	FAIL
22. ACID RESIST 463-PB-6-01 4.0% HCL	FAIL	FAIL	FAIL	FAIL	FAIL
23. ACID RESIST 463-PB-6-01 10% HCL 90 MIN.	PASS	PASS	PASS	PASS	PASS
24. ACID RESIST 463-PB-6-01 10% HCL 30 MIN.	PASS	PASS	PASS	PASS	PASS
25. ACID RESIST 463-PB-6-01 1.0% SULFURIC 16HRS	PASS	PASS	PASS	PASS	PASS
26. ACID RESIST 463 PB-6-01 1.0% NAOH 60MIN	PASS	PASS	PASS	PASS	PASS
27. CHIPPING @ RT 463 PB 19 01 1 PT	PASS-7	PASS 10	PASS-10	PASS-7	PASS-9
28. CHIPPING @ RT 463 PB 19 01 1 PT	FAIL 5	PASS 10	PASS-9	FAIL-0	PASS-8
29. TABLER WEAR ASTM D4060 81 300 CYCLES	N/A	PASS	PASS-9	PASS	PASS
30. IMPACT RESISTANCE 463-PB 19 01 80 IN/LBS	PASS	PASS	PASS	PASS	PASS

TABLE 3 (Continued)

CUSTOMER SPEC CHRYSLER MS-PP11-5

TEST METHOD	G		H	
	TPO	TPO	TPO	TPO
1. INITIAL ADH. 463PB-15-01 X-SCRIBE	PASS	PASS	PASS	PASS
2. INITIAL ADH. 463PB-15-01 GRID	PASS	PASS	PASS	PASS
3. INITIAL ADH. 463PB-15-01 30 DEGREE	PASS	PASS	PASS	PASS
4. INITIAL ADH. 463PB-15-01 90 DEGREE	PASS	PASS	PASS	PASS
5. ADH. BEFORE HUMIDITY 463-PB-9-01	PASS	PASS	PASS	PASS
6. HUMIDITY 463-PB-9-01 240 HRS.	PASS	PASS	PASS	PASS
7. ADH. AFTER HUMIDITY 463-PB-9-01 IMMED.	PASS	PASS	PASS	PASS
9. FADEOMETER 463-PB-17-01 240 HOURS	PASS	PASS	PASS	PASS
10. WEATHEROMETER 463-PB-16-01 240 HOURS	PASS	PASS	PASS	PASS
11. QUV ASTM G53-84 1000 HOURS	PASS	PASS ADH:HAZY	PASS	PASS
12. FLORIDA 12 MO EXP. 463-PB-34-01 5'SO	WIP	WIP	WIP	WIP
13. FLORIDA 24 MO EXP. 463-PB-34-01 5'SO	WIP	WIP	WIP	WIP
14. FLORIDA 36 MO EXP. 463-PB-34-01 5'SO	WIP	WIP	WIP	WIP
15. CYCLING 15 CYCLES 463-PB-22-01 METH.IV	PASS	PASS	PASS	PASS
16. MAR RESISTANCE 463-PB-43-01	PASS	PASS	PASS	PASS
17. SOAP & WATER RESIST. 463-PB-8-01	PASS	PASS	PASS	PASS
18. SOLVENT WIPE 463-PB-7-01 NAPHTHA	PASS	PASS	PASS	PASS
19. ACID RESIST 463-PB-6-01 0.5% HCL	FAIL	FAIL	FAIL	FAIL
20. ACID RESIST 463-PB-6-01 1.0% HCL	FAIL	FAIL	FAIL	FAIL
21. ACID RESIST 463-PB-6-01 2.0% HCL	FAIL	FAIL	FAIL	FAIL
22. ACID RESIST 463-PB-6-01 4.0% HCL	FAIL	FAIL	FAIL	FAIL
23. ACID RESIST 463-PB-6-01 10% HCL 90 MIN.	PASS	PASS	PASS	PASS
24. ACID RESIST 463-PB-6-01 10% NIT. 30 MIN.	PASS	PASS	PASS	PASS
25. ACID RESIST 463-PB-6-01 1.0% SUL. 16 HRS.	PASS	PASS	PASS	PASS
26. ACID RESIST 463-PB-6-01 1.0% SOD.HY.60 MIN.	PASS	PASS	PASS	PASS
27. CHIPPING @RT. 463-PB-39-01 1 PT.	PASS-8	FAIL-6	PASS-8	PASS-8
28. CHIPPING @0°F 463-PB-39-01 1 PT.	PASS-8	FAIL-6	FAIL-6	PASS-7
29. TABER WEAR ASTM D4060-81 200 CYCLES	PASS	PASS	PASS	PASS
30. IMPACT RESIST. 463-PB-19-01 80 IN/LBS	PASS	PASS	PASS	PASS

TABLE 3 (Continued)

CUSTOMER SPEC CHRYSLER MS-PP11-5

TEST METHOD	I	J	K
	TPO	TPO	TPO
1. INITIAL ADH. 463PB-15-01 X-SCRIBE	PASS	PASS	PASS
2. INITIAL ADH. 463PB-15-01 GRID	PASS	PASS	PASS
3. INITIAL ADH. 463PB-15-01 30 DEGREE	PASS	PASS	PASS
4. INITIAL ADH. 463PB-15-01 90 DEGREE	PASS	PASS	PASS
5. ADH. BEFORE HUMIDITY 463-PB-9-01	PASS	PASS	PASS
6. HUMIDITY 463-PB-9-01 240 HRS.	PASS	PASS	PASS
7. ADH. AFTER HUMIDITY 463-PB-9-01 IMMED.	PASS	PASS	PASS
9. FADEOMETER 463-PB-17-01 240 HOURS	PASS	PASS	PASS
10. WEATHEROMETER 463-PB-16-01 240 HOURS	PASS	PASS	PASS
11. QUV ASTM G53-84 1000 HOURS	PASS	PASS	PASS
12. FLORIDA 12 MO EXP. 463-PB-34-01 5'SO	WIP	WIP	WIP
13. FLORIDA 24 MO EXP. 463-PB-34-01 5'SO	WIP	WIP	WIP
14. FLORIDA 36 MO EXP. 463-PB-34-01 5'SO	WIP	WIP	WIP
15. CYCLING 15 CYCLES 463-PB-22-01 METHYLIV	PASS	PASS	PASS
16. MAR RESISTANCE 463-PB-43-01	PASS	PASS	PASS
17. SOAP & WATER RESIST. 463-PB-8-01	PASS	PASS	PASS
18. SOLVENT WIPE 463-PB-7-01 NAPHTHA	PASS	PASS	PASS
19. ACID RESIST 463-PB-6-01 0.5% HCL	FAIL	FAIL	FAIL
20. ACID RESIST 463-PB-6-01 1.0% HCL	FAIL	FAIL	FAIL
21. ACID RESIST 463-PB-6-01 2.0% HCL	FAIL	FAIL	FAIL
22. ACID RESIST 463-PB-6-01 4.0% HCL	FAIL	FAIL	FAIL
23. ACID RESIST 463-PB-6-01 10% HCL 90 MIN.	PASS	PASS	PASS
24. ACID RESIST 463-PB-6-01 10% NIT. 30 MIN.	PASS	PASS	PASS
25. ACID RESIST 463-PB-6-01 1.0% SUL. 16 HRS.	PASS	PASS	PASS
26. ACID RESIST 463-PB-6-01 1.0% NAOH 60 MIN.	PASS	PASS	PASS
27. CHIPPING @RT. 463-PB-39-01 1 PT.	PASS-8	PASS-8	PASS-8
28. CHIPPING @0°F 463-PB-39-01 1 PT.	PASS-6	FAIL-6	FAIL-6
29. TABER WEAR ASTM D4060-81 200 CYCLES	PASS	PASS	PASS
30. IMPACT RESIST. 463-PB-19-01 80 IN/LBS	PASS	PASS	PASS

CLAIMS

1. A process for manufacturing a metallized part comprising the steps of:
providing a part, as a substrate, made from a material selected from the group consisting of thermoplastic urethanes, thermoplastic urethane alloys, polyester alloys, thermoplastic olefins and
5 aluminum;
spray depositing directly on the substrate a combined primer/basecoat layer consisting of, by weight, a polymer material clear urethane resin 20-40%, black pigment paste 10-30%, solvent blend 40-60% including a catalyst 0.5-2.0% selected from the group consisting of metal and amine catalysts, covering the substrate, flashing and curing the combined primer/basecoat layer;
10 vacuum depositing directly on the combined primer/basecoat layer a layer of a corrosion prone metal material to form a discontinuous film covering the combined primer/basecoat layer including a plurality of discrete islands of the corrosion prone metal material appearing macroscopically as a continuous film of such metal and having a plurality of macroscopically unobservable channels between the islands to maintain the film electrically non-conductive over the
15 combined primer/basecoat layer; and
spray depositing a layer of clear resinous protective dielectric topcoat to completely cover the layer of vacuum deposited corrosion prone metal material and filling the channels for bonding the corrosion prone metal material to the combined primer/basecoat layer throughout the bottom of the channels by an adhesion force greater than two orders of magnitude in strength as compared to
20 the adhesion force between the topcoat and a continuous layer of the corrosion prone metal material, flashing and curing the topcoat layer.

2. A metallized part including a substrate material;

a combined primer/basecoat layer of a polymer material clear urethane resin 20-40%, black pigment paste 10-30%, solvent blend 40-60% including a catalyst 0.5-2.0% selected from the group consisting of metal and amine catalysts covering said substrate having a thickness of 1.0 to 2.0 mils;

a layer of vacuum deposited corrosion prone metal material covering said combined primer/basecoat layer with a plurality of discrete islands, the corrosion prone metal islands appearing macroscopically as a continuous film of such metal and having a plurality of macroscopically unobservable channels between the islands to maintain the film electrically non-conductive over the combined primer/basecoat layer; and

a clear resinous protective dielectric topcoat layer completely covering said layer of vacuum deposited corrosion prone metal material filling said channels for bonding said corrosion prone metal material to said combined primer/basecoat layer throughout the bottom of said channels by an adhesion force greater than two orders of magnitude in strength as compared to the adhesion force between said topcoat layer and a continuous layer of said corrosive metal material.

3. The metallized part of claim 2 further characterized by said substrate being selected from the group consisting of thermoplastic urethane (TPU), TPU alloys, polyester alloys, nylon, thermoplastic olefins (TPO) and aluminum.

4. The metallized part of claim 2 further characterized by said topcoat layer comprising a solvent solution of a resin selected from the group consisting of acrylics and urethanes.

5. The metallized part of claim 2 further characterized by said metal being selected from the group consisting of aluminum, cadmium, cobalt, copper, gallium, indium, iron, nickel, tin and zinc.

6. The metallized part of claim 5 further characterized by said metal being indium.

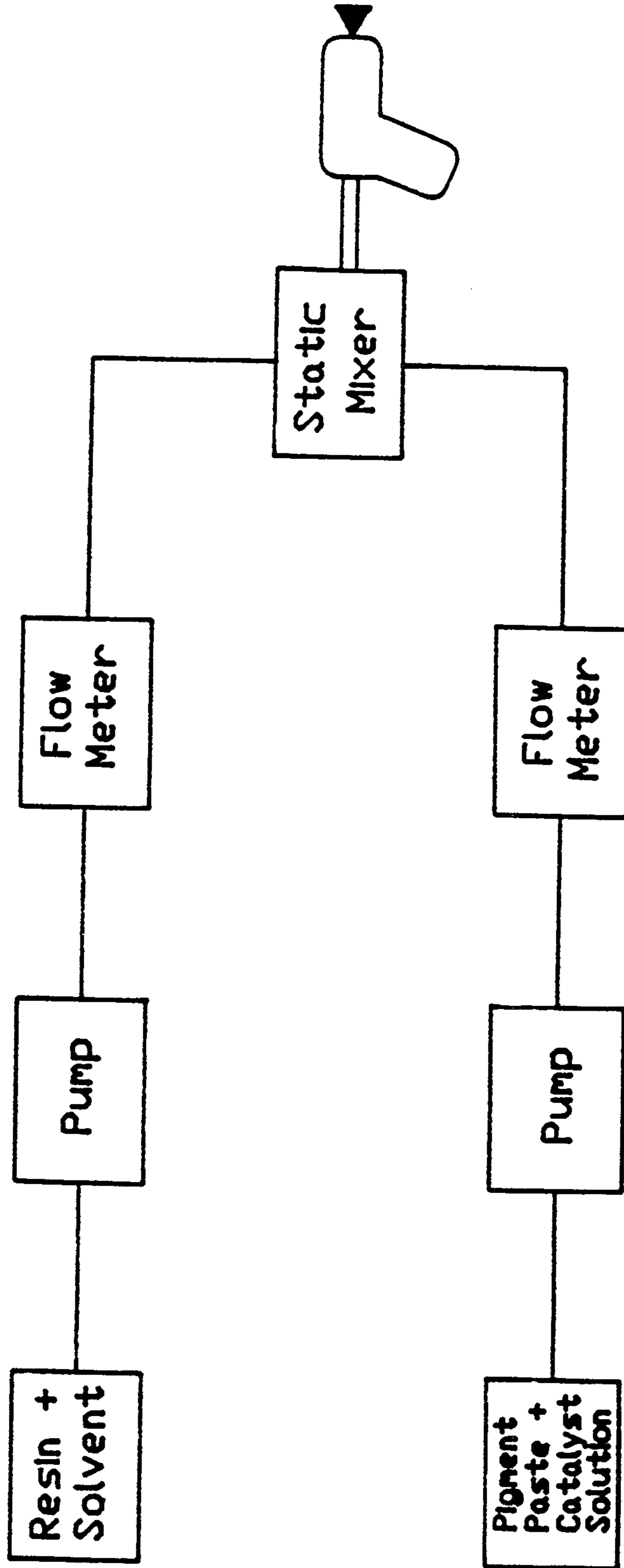

FIG 1

