

(19) World Intellectual Property
Organization
International Bureau



(43) International Publication Date
20 January 2005 (20.01.2005)

PCT

(10) International Publication Number
WO 2005/004927 A2

- (51) International Patent Classification⁷: **A61L** CO, CR, CU, CZ, DE, DK, DM, DZ, EC, EE, EG, ES, FI, GB, GD, GE, GH, GM, HR, HU, ID, IL, IN, IS, JP, KE, KG, KP, KZ, LC, LK, LR, LS, LT, LU, LV, MA, MD, MG, MK, MN, MW, MX, MZ, NA, NI, NO, NZ, OM, PG, PH, PL, PT, RO, RU, SC, SD, SE, SG, SK, SL, SY, TJ, TM, TN, TR, TT, TZ, UA, UG, US, UZ, VC, VN, YU, ZA, ZM, ZW.
- (21) International Application Number: PCT/KR2004/001706
- (22) International Filing Date: 12 July 2004 (12.07.2004)
- (25) Filing Language: Korean
- (26) Publication Language: English
- (30) Priority Data:
10-2003-0047642 12 July 2003 (12.07.2003) KR
- (84) Designated States (unless otherwise indicated, for every kind of regional protection available): ARIPO (BW, GH, GM, KE, LS, MW, MZ, NA, SD, SL, SZ, TZ, UG, ZM, ZW), Eurasian (AM, AZ, BY, KG, KZ, MD, RU, TJ, TM), European (AT, BE, BG, CH, CY, CZ, DE, DK, EE, ES, FI, FR, GB, GR, HU, IE, IT, LU, MC, NL, PL, PT, RO, SE, SI, SK, TR), OAPI (BF, BJ, CF, CG, CI, CM, GA, GN, GQ, GW, ML, MR, NE, SN, TD, TG).

- (71) Applicant and
(72) Inventor: **HAN, Jong-Hun** [KR/KR]; 4F, 63-1, Yeog Chon-dong, Eun Pyeong-gu, Seoul, 122-072 (KR).
- Published:
— without international search report and to be republished upon receipt of that report
- (81) Designated States (unless otherwise indicated, for every kind of national protection available): AE, AG, AL, AM, AT, AU, AZ, BA, BB, BG, BR, BW, BY, BZ, CA, CH, CN,
- For two-letter codes and other abbreviations, refer to the "Guidance Notes on Codes and Abbreviations" appearing at the beginning of each regular issue of the PCT Gazette.

(54) Title: AN AROMATIC EMITTING APPARATUS FOR USING CIGARJACK

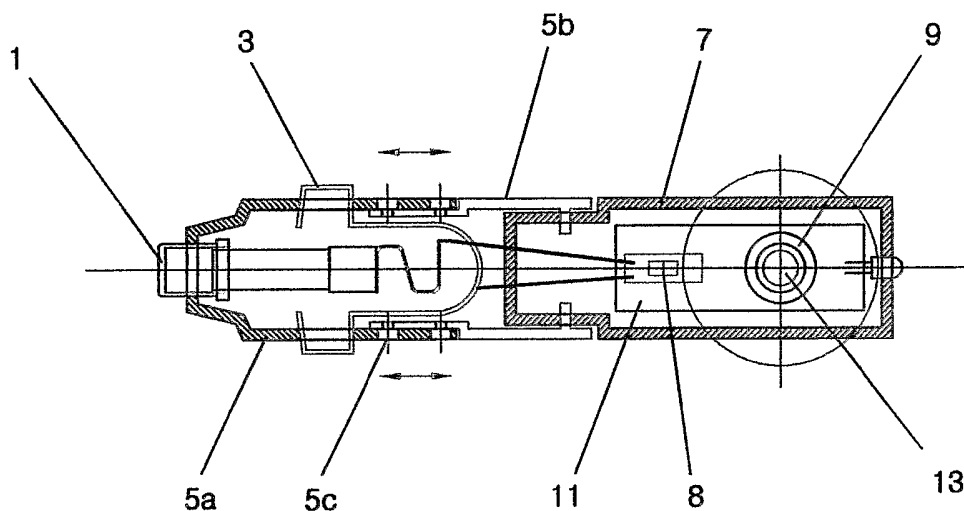

(57) Abstract: An aroma emitting apparatus for using a cigar-jack installed with a cartridge and, simultaneously, equipped with a plug whose angle and length are adjustable, which is widely used free from a mounted position of the cigar-jack of various kinds of cars to stably emit fragrance from the cartridge. In case of no use under the state that the cartridge is installed to the plug, an air-vent hole is tightly closed for minimizing consumption of liquid and alteration of fragrance. An auxiliary cigar-jack unit allows for another use for a cigar-jack item as well as an air refreshing effect.

WO 2005/004927 A2

AN AROMATIC EMITTING APPARATUS FOR USING CIGARJACK

5 [Technical Field]

The present invention relates to an aromatic emitting apparatus for evaporating liquid to diffuse fragrance by an electric power supplied from a cigar-jack, and simultaneously having an auxiliary cigar-jack unit for using another cigar-jack item, and more particularly to an aromatic emitting apparatus
10 for using a cigar-jack designed to have adjustable angle and a length for stably emitting fragrance from a cartridge, when a plug installed with the cartridge is inserted into the cigar-jack that is differently mounted for individual cars of diverse kinds.

15 [Background Art]

In association with cars, an air freshener is generally disposed within a car for refreshing the indoor air or deodorizing an unpleasant smell such as cigarette smoke. Such an air freshener for a car includes a filter in a container having a fragrant liquid therein and an air-venting lid. Thus, the fragrance is naturally
20 diffused for a prescribed period, thereby making an indoor space favorable.

However, the air freshener furnished to a car for naturally diffusing the fragrance has drawbacks. In more detail, the diffusion of fragrance is so slow that the air-venting lid should be open for a long time so as to obtain a sufficient air refreshing effect. Furthermore, an actual driving time is 2~3 hours or so and the car is left empty during the other time. Accordingly, unless a driver closes the
25 container every time, the air freshener is wasted due to unnecessary diffusion, and thus has to be replaced within 1~2 month(s).

Moreover, an initially selected fragrance of the air freshener cannot be replaced until consuming thoroughly. Additionally, no fragrance is emitted after
30 elapsing a certain period. Therefore, overall air freshener should be newly replaced.

Almost all air fresheners are attached to the cars, using a both-sided tape on a bottom surface of the container. Accordingly, it is difficult to detach the container once being attached. Otherwise, when the container once detached is

to be attached to another place, a bonding force of the both-sided tape is lowered to be apt to have the container fell while driving, thereby spilling liquid in the container.

5 Meantime, an air freshening device equipped with a motor and a fan using a power source of a car is also suggested for quickly diffusing fragrance throughout the indoor air as compared with the naturally diffusing system. However, a plug connected with a power supply cable should be connected to a cigar-jack and a container, which is inconvenient and complicates peripheral units.

10 Recently, cigar-jacks are mounted differently per cars for contriving convenience of drivers. That is, typically, most plugs were horizontally inserted. Currently, many kinds of cars on the market have a structure with a slanted cigar-jack. Therefore, if a plug equipped with an air freshener container is inserted into a car having the slanted cigar-jack, a cartridge loaded on the
15 freshener plug is slanted. As the result, the liquid is liable to leak out of the cartridge, so that the plug loaded with the air freshener container cannot be widely used. A cigar-jack installed together with an ashtray generally has a deep and slanted structure. In this case, when the cartridge is horizontally installed, the cartridge may interfere one portion of the car such as a lid of the ashtray.

20 Moreover, when the cigar-jack is used for an air freshener, another use thereof for, e.g., a handsfree mobile phone is not available. Although a multi socket may be used, it should be connected to a bothersome power supply cable that spoils an inside view and is inconvenient.

25 [Disclosure of Invention]

In order to solve the above-enumerated problems, the present invention provides an aroma emitting apparatus for using a cigar-jack installed with a cartridge and, simultaneously, equipped with a plug whose angle and length are
30 adjustable, for being widely used free from a mounted position of the cigar-jack of various kinds of cars, thereby stably emitting fragrance from the cartridge. If the apparatus is not used under the state that the cartridge is installed to the plug, an air-vent hole is tightly closed for minimizing consumption of liquid and alteration of fragrance.

The present invention also provides an aroma emitting apparatus for using a cigar-jack having an auxiliary cigar-jack unit allowing for another use for a cigar-jack item as well as the air refreshing effect.

5 The present invention still provides an aroma emitting apparatus for using a cigar-jack permitting to refill a cartridge and to replace liquid filled in the cartridge at a user's desire, thereby providing various kinds of fragrance.

The present invention yet provides an aroma emitting apparatus clipped to a grille of an air-conditioner using a clip or a rotating member, thereby diffusing fragrance by means of ventilated air without using a cigar-jack.

10 To achieve the above objects, there is provided an aroma emitting apparatus for using a cigar-jack including a main plug body that has one end formed with a road portion inserted to the cigar-jack for electrical connection, and a plurality of plates oppositely installed to an outer circumference of the main plug body for being fixed to the cigar-jack. Also, an auxiliary plug body can adjust
15 a length of the main plug body by using a length control bolt. A rotating member is connected to an end of the auxiliary plug body, and is rotated in accordance with an angle of inserting the main plug body into the cigar-jack to maintain a horizontal state. A cartridge installed to a lower portion of the main plug body has a filter externally protruding from the inside the cartridge. An angle adjusting unit
20 for connecting the main plug body to the rotating member controls a rotating angle. An open/close unit is mounted within the rotating member for controlling opening/closing of a fragrance exhaust. A switching unit is mounted within the rotating member for performing an ON/OFF operation to electrically connect to the road portion. A heating unit is internally formed within the rotating member
25 and is selectively supplied with a power source in accordance with the ON/OFF operation of the switching unit for thereby being heated to evaporate liquid within the cartridge. A holding unit has one end with a fixing portion coupled to the rotating member or the cartridge, and the other end with a gripping portion for firmly holding a predetermined frame. Furthermore, a rotatably formed auxiliary
30 cigar-jack has one end coupled with a connector of a PCB for being supplied with the power source, and the other end capable of receiving a cigar-jack item.

[Brief Description of Drawings]

The above and other features and advantages of the present invention will become more apparent by describing in detail exemplary embodiments thereof with reference to the attached drawings in which:

5 FIG. 1 is a front sectional view showing one embodiment of an aromatic emitting apparatus for using a cigar-jack according to the present invention;

FIG. 2 is a plan sectional view of FIG. 1;

FIGS. 3a and 3b are a front view and a plan view showing another embodiment of a heating unit according to the present invention;

10 FIGS. 4 and 5 are front sectional views showing another embodiment of an angle adjusting unit according to the present invention;

FIG. 6 is a plan sectional view showing another embodiment of an open/close unit for a fragrance exhaust according to the present invention;

FIG. 7 shows an operational state the aroma emitting apparatus for using a cigar-jack according to the present invention;

15 FIG. 8 is a front sectional view showing a state of moving a tension rib that is the angle control device;

FIG. 9 is a plan sectional view showing one embodiment of a length control unit according to the present invention; and

20 FIG. 10 is a plan sectional view showing one embodiment of the length control unit and an auxiliary cigar-jack according to the present invention.

[Best Mode for Carrying Out the Invention]

The present invention will now be described more fully with reference to the accompanying drawings. The invention may, however, be embodied in many
25 different forms and should not be construed as being limited to the embodiments set forth herein; rather these embodiments are provided so that this disclosure will be thorough and complete, and will fully convey the concept of the invention to those skilled in the art.

Referring to FIGS. 1, 7, 9 and 10, a preferred embodiment of the present
30 invention will be described.

An aroma emitting apparatus for using a cigar-jack according to the present invention can be widely used for cigar-jacks provided to respectively different places of various kinds of cars. Using a power source via a cigar-jack, liquid is evaporated for diffusing fragrance. Also, an auxiliary cigar-jack unit is

installed. Referring to FIGS. 1, 2, 9 and 10, the aroma emitting apparatus has one end with a road portion 1 inserted to a cigar-jack (not shown) for electrical connection. A main plug body 5a installed to oppose to an outer periphery includes a plurality of plates 3 for being fixed to the cigar-jack. An auxiliary plug body 5b is coupled to the main plug body 5a by means of length control bolts 5c, so that the length can be adjusted. A fuse 2 is connected to the road portion 1 of the main plug body 5a. A bent-form plate spring 4 is connected to the fuse 2 for being supplied with a cigar-jack power source via the road portion 1 to thereby apply it to a heating unit that will be described later. A rotating member 7 rotatably connected to an end of the main plug body 5a or the auxiliary plug body 5b has a coupling hole 7a for receiving a cartridge 14 by coupling. Additionally, a fragrance exhaust 7a for externally diffusing fragrance emitted from liquid within the cartridge 14 is formed in an upper portion of the rotating member 7. A hinge 6 is installed by penetrating through a coupling portion of the plug body 5/auxiliary plug body 5b and the rotating member 7, thereby acting as a swinging center of the rotating member 7. The cartridge 14 is loaded to a lower portion of the rotating member 7, and has an externally projecting filter 13 and a lid 12 fitted into the coupling hole 7a of the rotating member 7. An angle adjusting unit connects the main plug body 5a/auxiliary plug body 5b to the rotating member 7 while controlling a rotating angle. An open/close unit for a fragrance exhaust is installed to a lower portion of the rotating member 7, in which an open/close member 15 with a rack structure 17 is connected to a pinion 16. Thus, the fragrance exhaust is adjusted to be open/closed using a knob 18 coupled to a central shaft of the pinion 16. A slide switch 8 installed within the rotating member 7 is on/off for electrical connection to the plate spring 4. The heating unit disposed within the rotating member 7 is selectively supplied with a power source in accordance with the ON/OFF operation of the slide switch 8, thereby being heated for evaporating the liquid within the cartridge 14. A light emitting diode (LED) 10 is installed to a rear end of the rotating member 7 for displaying the power supply under the ON operation of the slide switch 8. A holding unit having one end equipped with a fixing portion coupled to the rotating member 7 or the cartridge 14 and the other end equipped with a gripping portion to be held to a predetermined frame. An auxiliary cigar-jack has one end rotatably coupled to a

connector of a printed circuit board (PCB) board to be supplied with the power source and the other end shaped to be installed with a cigar-jack item.

Here, the coupling hole 7a of the rotating member 7 is formed with a female screw, and the lid 12 of the cartridge 14 is formed with a male screw, thereby
5 being mutually engaged with each other. The coupling hole may be shaped as a hook, and any structure capable of being coupled with the cartridge is acceptable.

The angle adjusting unit includes a tension rib 22 formed along an end surface of the plug body 5, and an indent portion 21 formed along the end
10 surface of the rotating member 7 corresponding to the tension rib 22. Therefore, when the rotating member 7 is bent to secure a horizontal state in accordance with an angle of putting a plug body 5 into the cigar-jack, a projecting portion of the tension rib 22 is brought into meshing engagement with the indent portion 21, thereby adjusting the rotating angle.

The indent portion 21 and the tension rib 22 form the angle adjusting unit in
15 this preferred embodiment, which however is not limited thereto. The indent portion 21 may be shaped as the projecting portion of the tension rib 22. In another embodiment shown in FIG. 4, it may be formed as a bendable folding shape 31. The angle adjusting unit has an indent portion 21 and a ridge portion 23
20 as shown in FIG. 5, which is not limited thereto but the indent portion and the ridge portion may have a meshed or a boss-like form. That is, any structure may be applied as the angle adjusting unit only when the folded position of the rotating member 7 can be maintained.

The heating unit is installed within the rotating member 7, and has one end
25 with a hole for receiving the filter 13 of the cartridge 14 therein. The PCB 11 for supplying the power source in accordance with the ON/OFF operation of the switch 8 is formed at the other end of the heating unit, in which a connector capable of supplying the power source to the auxiliary cigar-jack is provided. Also, a doughnut-shaped PTC device 9 for evaporating the liquid permeating in
30 the filter 13 of the cartridge 14 contacts the PCB 11 in a form of, e.g., a plate spring.

Another embodiment of the PTC device 9 illustrated in FIGS. 3a and 3b. Here, the doughnut-shaped PTC device 9 may be replaced with a stripe resistor 41. In this case, manufacturing cost of the heating unit can be minimized.

The holding unit includes a clip 61 that has a ring fixing portion inserted and fixed to one side of the rotating member or the cartridge, and a gripping portion with a plurality of bosses throughout the facing inner surfaces thereof for firmly gripping a grille of a ventilator.

5 The auxiliary cigar-jack unit is supplied with the power source from the connector of the PCB 11 provided at one end for simultaneously using a cigar-jack item of another usage, which is rotatably designed for controlling the direction (up and down) in view of a user's convenience.

10 An operational state of the present invention constructed as above will be described with reference to FIGS. 1, 2 and 9.

First, the container and the lid 12 of the cartridge 14 are screw-coupled to the coupling hole 7a of the rotating member 7, thereby simply installing the cartridge 14. At this time, the filter 13 of the cartridge penetrates through a hole formed in the PCB board 11.

15 Then, the plug body 5 is inserted in the cigar-jack of a car. At this time, when the cigar-jack is at a level with the horizontal line, the angle adjusting unit is manipulated to make the plug body 5 and the rotating member 7 be at a level with each other. Upon manipulating the switch 8 to the ON state, the power source of the car is supplied to the heating unit 9 of the PCB 11 via the road portion 1 and the plate spring 4 to thus generate heat. In turn, the heat generated from the heating unit 9 evaporates the liquid permeating in the filter 13, and evaporated
20 fragrance is externally diffused via the fragrance exhaust 7b of the rotating member 7.

If it is intended to stop the diffusion of fragrance within the car, the switch
25 8 is manipulated to OFF. Then, the liquid within the cartridge 14 is just naturally emitted to minimize uneconomical consumption. On the other hand, if it is not used, the fragrance exhaust 7b is tightly closed by manipulating the knob 18 so as to operate the open/close member 15 by the action of the pinion 16 and the rack 17. By doing so, not only the natural consumption of the liquid but also alteration
30 of the fragrance resulting from a lapse of time can be prevented.

Another embodiment of the open/close member 15 is shown in FIG. 6, in which an eccentric cam 51 may substitute for the pinion and the rack. In this case, an operating distance can be adjusted by a combination of at least one rib 15a as

a stopper formed to an outer circumference of the eccentric cam 51 and one side of the open/close member 15.

More simply, the fragrance exhaust 7b is interrelated with the slide switch 8 to be open/closed, which is more economical and efficient method.

5 When the liquid within the cartridge 14 is exchanged, the cartridge 14 is removed from the rotating member 7 for being replaced with another cartridge. Otherwise, another liquid is refilled just by opening the lid 12 of the cartridge 14. Therefore, a driver can easily change the liquid as desired.

10 Meantime, when the cigar-jack is slanted, the rotating member 7 is folded centering about the hinge 6 before or after putting the plug body 5 in the cigar-jack to adjust the inserting angle. At this time, the projecting portion of the tension rib 21 formed to the plug body 5 is brought into meshing engagement with the indent portion 21 of the rotating member 7, thereby controlling the angle of the rotating member 7. By an engaging force between the indent portion 21 and the
15 projecting portion of the tension rib 21, the rotating member 7 maintains the horizontal state. Furthermore, the cartridge 14 also maintains the horizontal state involving no inclination, so that the liquid is not leaked but is stably emitted.

20 If the cigar-jack is deeply formed or the cartridge partially interferes within the car, the main plug body 5a and the auxiliary plug body 5b are elongated when coupling by means of the length control bolt 6c. By doing so, the cartridge can maintain the horizontal state for stably emitting the liquid.

25 While the present invention has been particularly shown and described with reference to exemplary embodiments thereof, it will be understood by those of ordinary skill in the art that various changes in form and details may be made therein without departing from the spirit and scope of the present invention as defined by the following claims.

[Industrial Applicability]

30 According to the present invention constructed as above, liquid within a cartridge is evaporated to externally diffuse quickly using a power source of a cigar-jack supplied in accordance with ON/OFF operation of a switch. The cartridge can maintain a position at a level with the horizontal line regardless of the cigar-jack position diversely installed for each car, thereby stably emitting fragrance.

Since the cartridge can be installed to and separated from a plug that is inserted to the cigar-jack, the cartridge can be selectively loaded by containing liquid suitable for a user's taste. In case of no use, a fragrance exhaust is tightly closed by means of an open/close unit, thereby preventing unnecessary
5 consumption of liquid and alteration of fragrance resulting from a lapse of time.

Also, an auxiliary cigar-jack unit allows for both an air refreshing function and another use for a cigar-jack item such as a handsfree mobile phone, thereby eliminating a driver's inconvenience.

10

[CLAIMS]

1. An aroma emitting apparatus for using a cigar-jack characterized by:

5 a main plug body having one end formed with a road portion inserted to the cigar-jack for electrical connection, and a plurality of plates oppositely installed to an outer circumference of the main plug body for being fixed to the cigar-jack;

an auxiliary plug body capable of adjusting a length of the main plug body by using a length control bolt;

10 a rotating member connected to an end of the auxiliary plug body, and rotated in accordance with an angle of inserting the main plug body into the cigar-jack to maintain a horizontal state;

a cartridge installed to a lower portion of the main plug body, and having a filter externally protruding from the inside the cartridge;

15 angle adjusting means for connecting the main plug body to the rotating member and controlling a rotating angle;

open/close means mounted within the rotating member for controlling opening/closing of a fragrance exhaust;

20 switching means mounted within the rotating member for performing an ON/OFF operation to electrically connect to the road portion;

heating means internally formed within the rotating member and selectively supplied with a power source in accordance with the ON/OFF operation of the switching means for thereby being heated to evaporate liquid within the cartridge; and

25 holding means having one end with a fixing portion coupled to the rotating member or the cartridge, and the other end with a gripping portion for firmly holding a predetermined frame.

2. An aroma emitting apparatus for using a cigar-jack characterized by:

30 a main plug body having one end formed with a road portion inserted to the cigar-jack for electrical connection, and a plurality of plates oppositely installed to an outer circumference of the main plug body for being fixed to the cigar-jack;

an auxiliary plug body capable of adjusting a length of the main plug body by using a length control bolt;

a rotating member connected to an end of the auxiliary plug body, and rotated in accordance with an angle of inserting the main plug body into the cigar-jack to maintain a horizontal state;

a cartridge installed to a lower portion of the main plug body, and having a filter externally protruding from the inside the cartridge;

angle adjusting means for connecting the main plug body to the rotating member and controlling a rotating angle;

open/close means mounted within the rotating member for controlling opening/closing of a fragrance exhaust;

switching means mounted within the rotating member for performing an ON/OFF operation to electrically connect to the road portion;

heating means internally formed within the rotating member and selectively supplied with a power source in accordance with the ON/OFF operation of the switching means for thereby being heated to evaporate liquid within the cartridge;

holding means having one end with a fixing portion coupled to the rotating member or the cartridge, and the other end with a gripping portion for firmly holding a predetermined frame; and

a rotatably formed auxiliary cigar-jack having one end coupled with a connector of a PCB for being supplied with the power source, and the other end capable of receiving an cigar-jack item.

3. The apparatus of either one of claims 1 and 2, wherein the rotating member is characterized by a coupling portion formed to a lower portion thereof capable of being loaded with the cartridge, the fragrance exhaust formed in an upper portion thereof, and one end formed with a knob mounted for manipulating the opening/closing of the fragrance exhaust, a rear end installed with a display window of a light emitting diode, and the connector formed to a side plane coupled with the auxiliary cigar-jack; and

the cartridge including a container screw-coupled to the coupling portion, a lid, and a filter.

4. The apparatus of either one of claims 1 and 2, wherein the angle adjusting means is characterized by a tension rib formed along an end surface of the main plug body, and an indent portion formed along an end surface of the rotating member corresponding to a projecting portion of the tension rib.

5

5. The apparatus of either one of claims 1 and 2, wherein the angle adjusting means is characterized by a bendable folding shape.

10

6. The apparatus of either one of claims 1 and 2, wherein the angle adjusting means is characterized by at least one indent portion formed along the end surface of the main plug body, and a ridge portion formed along an end surface of the rotating member corresponding to the indent portion.

15

7. The apparatus of either one of claims 1 and 2, wherein the heating means is characterized by:

20

a printed circuit board installed within the rotating member for supplying the power source in accordance with the ON/OFF operation of the switching means, and having a light emitting diode for displaying the supply of the power source and having the connector for supplying the power source to the auxiliary cigar-jack; and

a PTC device installed on the printed circuit board for evaporating liquid permeating in the filter of the cartridge.

25

8. The apparatus of either one of claims 1 and 2, wherein the heating means is characterized by:

30

a printed circuit board installed within the rotating member for supplying the power source in accordance with the ON/OFF operation of the switching means, and having a light emitting diode for displaying the supply of the power source and having the connector for supplying the power source to the auxiliary cigar-jack; and

a plurality of stripe resistors installed on the printed circuit board for evaporating liquid permeating in the filter of the cartridge.

9. The apparatus of either one of claims 1 and 2, wherein the open/close means is characterized by:

an open/close member of the fragrance exhaust installed within the rotating member and having one side with a rack structure;

5 a pinion coupled to the rack of the open/close member; and

an operative knob connected to a central shaft of the pinion for operating the open/close member.

10. The apparatus of either one of claims 1 and 2, wherein the open/close means of the fragrance exhaust is characterized by:

an open/close member installed within the rotating member and having at least one rib as a stopper at one side surface;

an eccentric cam with an operating distance adjustable by a combination with the rib as a stopper of the open/close member; and

15 an operative knob connected to a rotating shaft of the eccentric cam for operating the open/close member.

11. The apparatus of either one of claims 1 and 2, wherein the open/close means of the fragrance exhaust is characterized by:

20 an operative knob for operating the open/close member by interrelating with a slide switch on the PCB installed within the rotating member.

12. The apparatus of either one of claims 1 and 2, wherein the length control means is characterized by a plurality of screw coupling portions where the main plug body is coupled with the auxiliary plug body, and a length control bolt.

25

13. The apparatus of claim 2, wherein the auxiliary cigar-jack unit is characterized by:

a connector of the PCB at one end; and

30 a structure movable up and down and capable of receiving a cigar-jack item.

[Drawings]

[FIG. 1]

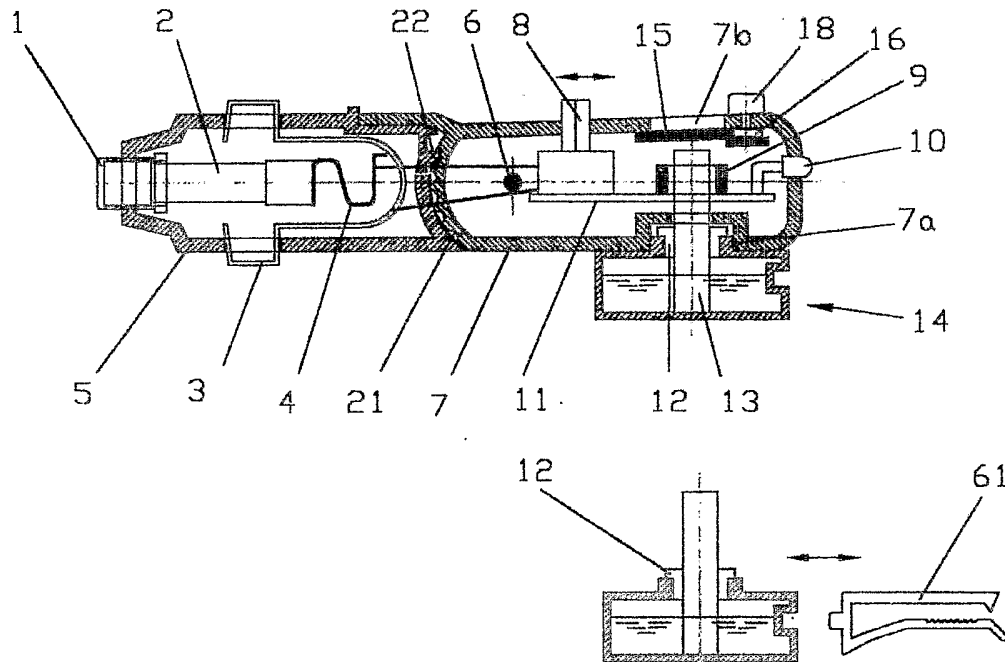

[FIG. 2]

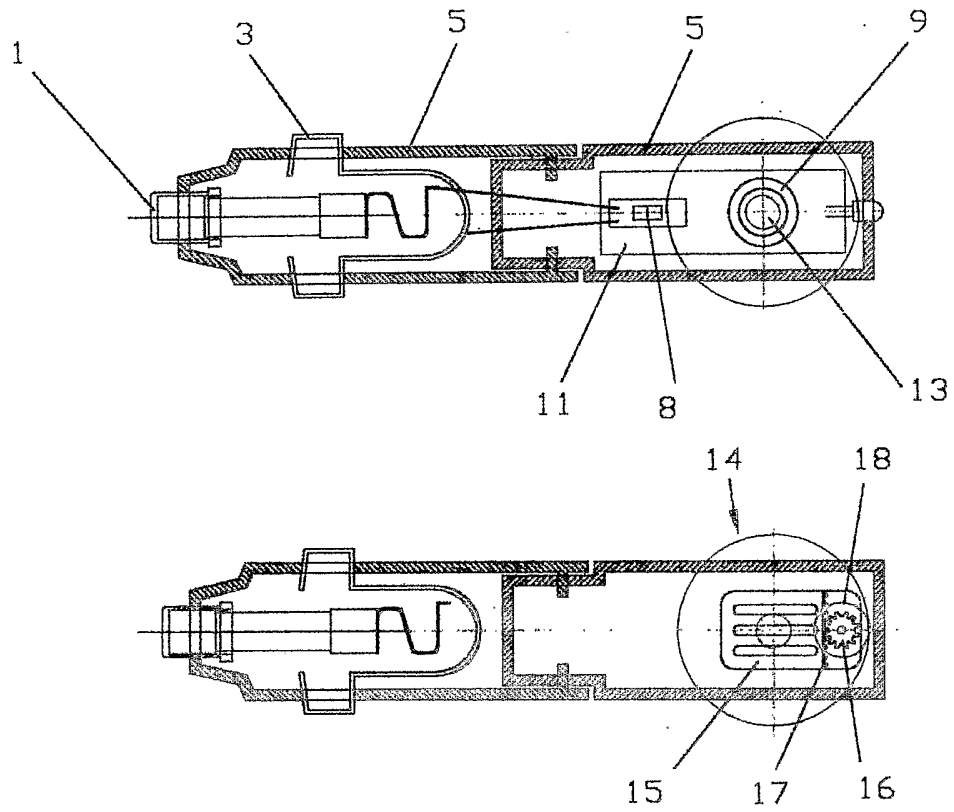

[FIG. 3]

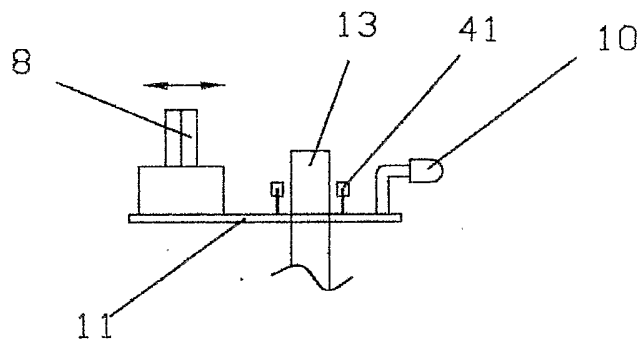

[FIG. 3a]

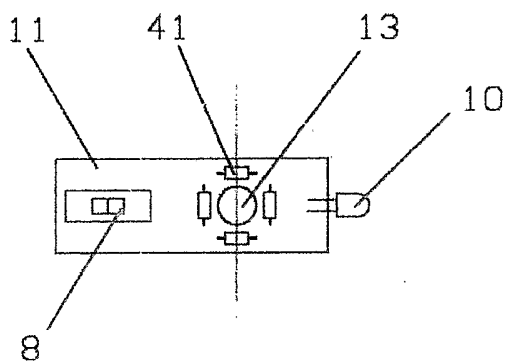

[FIG. 3b]

[FIG. 4]

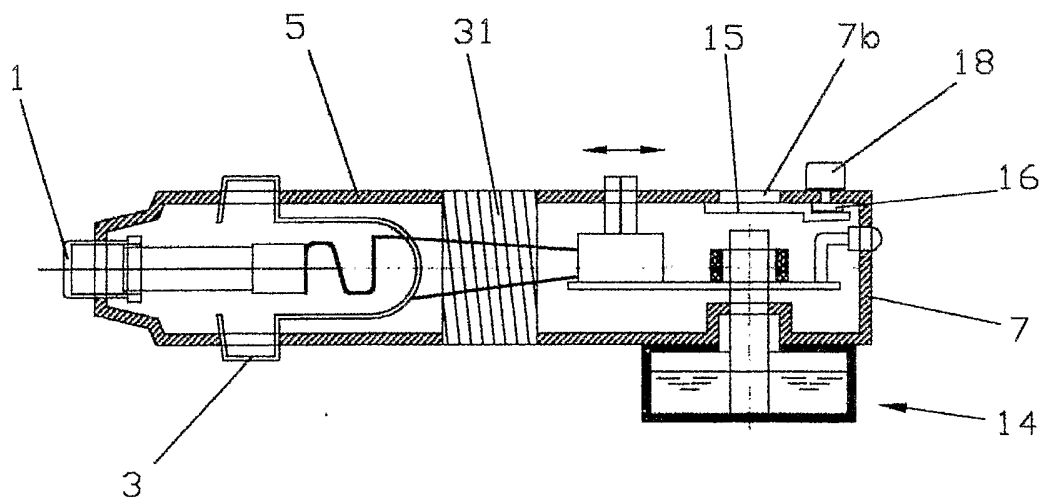

[FIG. 5]

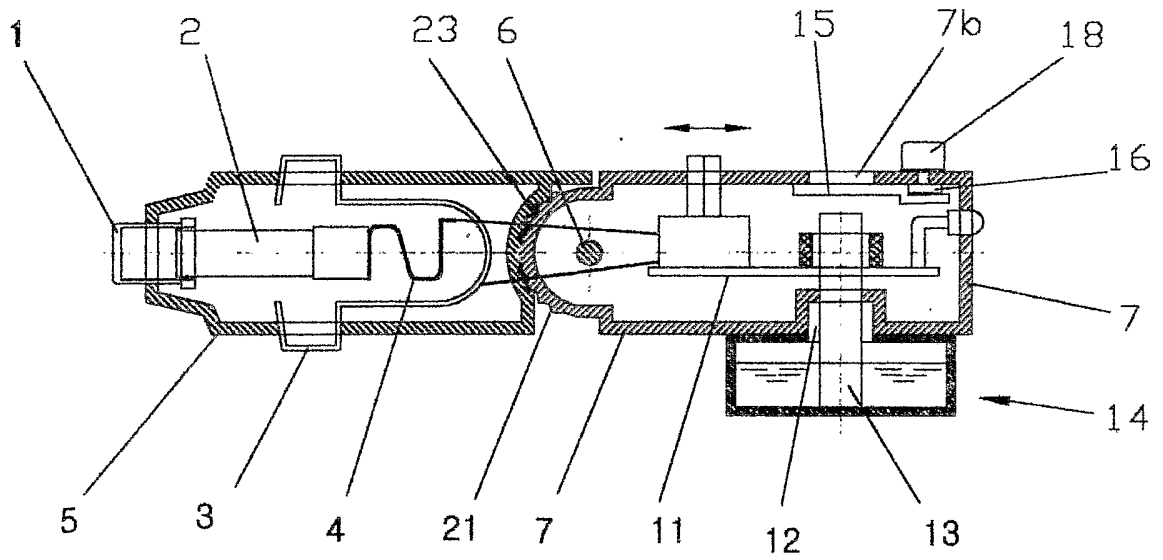

[FIG. 6]

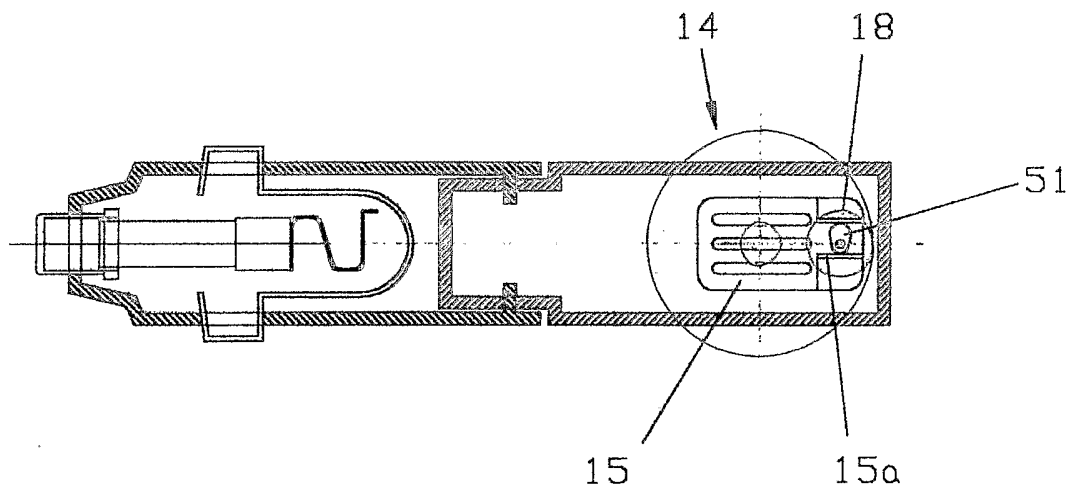

[FIG. 7]

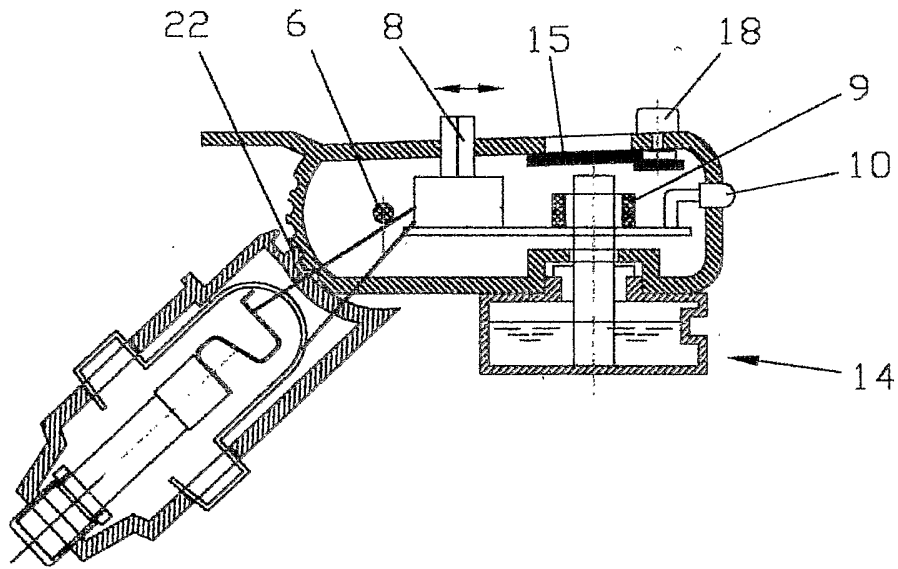

[FIG. 8]

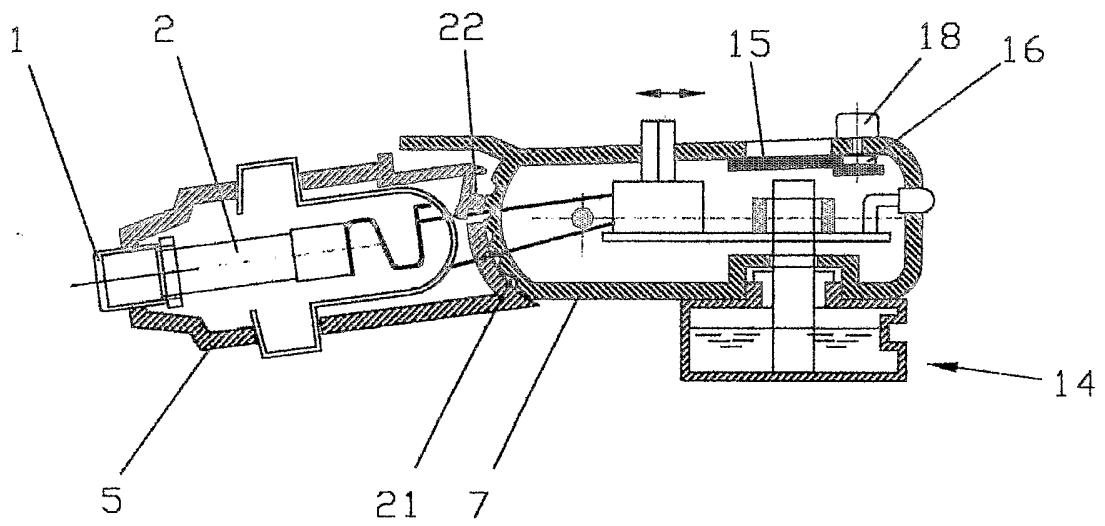

[FIG. 9]

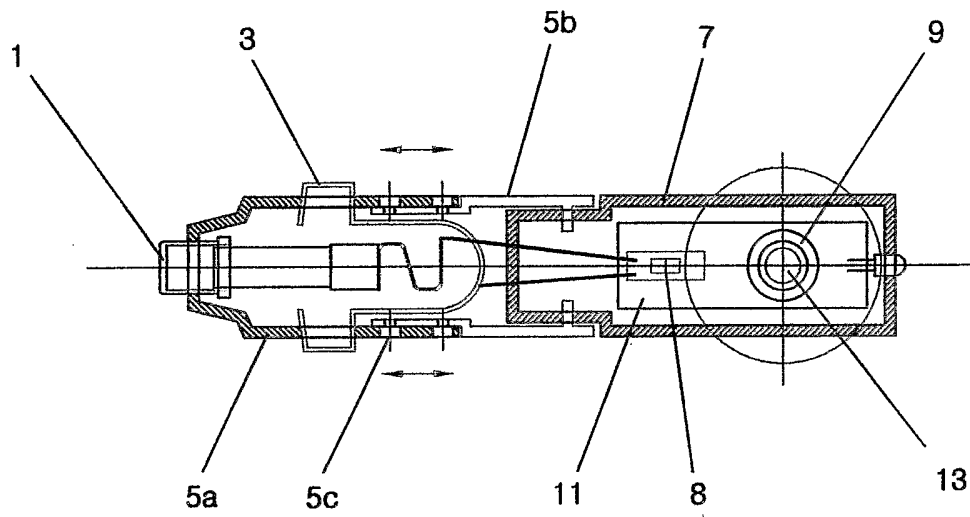

[FIG. 10]

