



(12) **EUROPEAN PATENT APPLICATION**

(43) Date of publication:
10.01.2018 Bulletin 2018/02

(51) Int Cl.:
A45B 19/02 (2006.01)

(21) Application number: **17382426.9**

(22) Date of filing: **30.06.2017**

(84) Designated Contracting States:
AL AT BE BG CH CY CZ DE DK EE ES FI FR GB GR HR HU IE IS IT LI LT LU LV MC MK MT NL NO PL PT RO RS SE SI SK SM TR
 Designated Extension States:
BA ME
 Designated Validation States:
MA MD

• **Martínez Saugart, José Antonio**
28034 Madrid (ES)

(72) Inventors:
 • **MARTÍNEZ DEL RÍO, José**
28034 Madrid (ES)
 • **VALLEJO HIDALGO, Juan Alfonso**
28029 Madrid (ES)
 • **RODRÍGUEZ GARCÍA, Juan Carlos**
28034 Madrid (ES)

(30) Priority: **08.07.2016 ES 201600473**

(71) Applicants:
 • **Martínez del Río, José**
28034 Madrid (ES)
 • **Vallejo Hidalgo, Juan Alfonso**
28029 Madrid (ES)

(74) Representative: **Elzaburu S.L.P.**
C/ Miguel Angel, 21
28010 Madrid (ES)

(54) **INFLATABLE UMBRELLA**

(57) Inflatable umbrella that includes the following elements:

- Nozzle (5) with a cap attached to the valve itself for blowing air into the inside.
- Structure formed by at least six elastic compartments, circular in section and with a variable length, which hold the air previously blown in through the nozzle (5).
- Panels. Each surface acts as protection against the water of the rain.
- Handle. Positioned at the centre of the umbrella, under the inflation nozzle.
- Loops formed by rectangular pieces and arranged such that an elastic cord (11), adjustable so as to fit the concave shape of the umbrella, may be passed through each one.
- Elastic cord (11) with a cord tension adjustment device (12).
- Bag. A small spherical bag with an opening to hold the inflatable umbrella, wherein the folded umbrella occupies the space of a sphere.

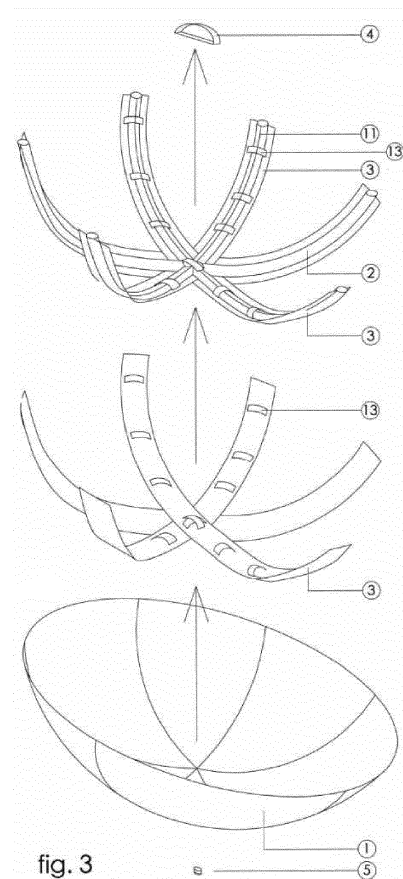

fig. 3

Description

Field of the invention

[0001] This invention relates to a balloon capable of converting into an umbrella that is light-weight and very small in size.

Background of invention

[0002]

1. Title: COLLAPSIBLE UMBRELLA THAT LIES FLAT WHEN CLOSED.
International Classification: A45B25/02 (2006.01) A45B25/06 (2006.01)
Publication Number: ES0151845 U (1970.01.01)
Other Publications: ES0151845 Y (1970.07.01)
Priorities: DE1967K062574 (1967.06.16)
First Applicant's Name: KORTEMBACH & RAUH K.G.
Application Number: U0151845 (1968.06.11)

2. Title: COLLAPSIBLE UMBRELLA
International Classification: A45B19/06 (2006.01) A45B19/10 (2006.01)
Publication Number: ES0168316 U (1971.09.01)
Other Publications: ES0168316 Y (1972.02.16)
Priorities: DE19702022515 (1970.05.08)
First Applicant's Name: KORTENBACH & RAUH K.G.
Application Number: U0168316 (1971.04.25)

3. Title: IMPROVEMENTS IN OR TO COLLAPSIBLE UMBRELLAS
International Classification: A45B19/06 (2006.01) A45B25/06 (2006.01)
Publication Number: ES0371584A1 (1971.11.01)
Priorities: DE19681782611 (1968.09.24)
First Applicant's Name: BREMSHEY & CO.
Application Number: P0371584 (1969.09.16)

4. Title: COLLAPSIBLE UMBRELLA
Publication Number: ES0008589 U (1944.04.01)
First Applicant's Name: Cano y de Aspe, Francisco
Application Number: U0008589 (1943.05.18)

5. Title: COLLAPSIBLE UMBRELLA
International Classification: A45B19/06
Publication Number: ES0357093 A1 (1970.02.16)
Priorities: DE19671632514 (1967.08.12)
First Applicant's Name: ROSENKAIMER, G.M.B.H.
Application Number: P0357093 (1968.08.09)

6. Title: ILLUMINATED AIR BALLOON
International Classification: A63H27/10 (2006.01)
Inventors: HALLIBURTON, JAMES
Publication Number: ES2532718 T3 (2015.03.31)

Date of Filing: (2012.03.15)

Other Publications: EP2686080 A1 (2014.01.22)
EP2686080 B1 (2014.12.17) WO2012123747
Priorities: GB20110004442 (2011.03.16)

First Applicant's Name: Seatriever International Holdings Limited (100.0%)
Application Number: PCT/GB2012/050568 (2012.03.15)

7. Title: COLLAPSIBLE UMBRELLA
International Classification: A45B19/10 (2006.01)
Publication Number: ES0337738 A1 (1968.03.01)
Priorities: DE1966B086863 (1966.04.28)
First Applicant's Name: BREMSHEY & CO.
Application Number: P0337738 (1967.03.08)

8. Title: COLLAPSIBLE UMBRELLA
International Classification: A45B19/00 (2006.01) A45B19/10 (2006.01) A45B25/22 (2006.01)
Publication Number: ES0181364 U (1973.03.16)
Other Publications: ES0181364 Y (1975.05.16)
Priorities: DE19712129265 (1971.06.12)
First Applicant's Name: KORTENBACH & RAUH, K.G.
Application Number: U0181364 (1972.06.09)

9. Title: IMPROVEMENTS IN RIBS FOR COLLAPSIBLE UMBRELLAS
International Classification: A45
Publication Number: ES0289626A1 (1963.11.01)
Priorities: DEX289626 (1962.10.06)
First Applicant's Name: KORTENBACH & RAUH K.G.

10. Title: IMPROVEMENTS IN AUTOMATICALLY OPENING COLLAPSIBLE UMBRELLAS
Publication Number: ES0307222 A1 (1965.03.01)
Priorities: DEX307222 (1964.02.20)
First Applicant's Name: KORTENBACH & RAUH K.G.
Application Number: P0307222 (1964.12.17)

11. Title: IMPROVEMENTS IN THE MANUFACTURE OF COLLAPSIBLE UMBRELLAS
International Classification: A45B
Publication Number: ES0296545 A1 (1964.09.16)
First Applicant's Name: BREMSHEY & CO.
Application Number: P0296545 (1964.02.1964)

Explanation of the invention

[0003] This invention has developed an item that provides protection from the rain in the form of an umbrella on opening, together with the elastic structure of latex, with a balloon as an opening and structural support mechanism. Its main advantage is the extremely small space that it takes up and its rapid system of inflation and deflation for opening and closing, with two embodiments

according to the materials.

Embodiment 1:

An elastomeric material such as isobutylene and nylon.

[0004] This umbrella is formed from eight parts:

1. Nozzle. Air is blown into the interior in order to open and give shape to the structure of the umbrella by means of an opening or nozzle made of polyvinyl chloride (PVC) with a cap attached to the valve itself.

2. Structure. Formed by elastic compartments (at least six) made of isobutylene (the same material used to make bicycle tire inner tubes), circular in section and variable in length for holding the air previously pumped in through the PVC nozzle, such that the umbrella opens and in this way is able to support the panels, acting as the umbrella's ribs.

3. Panels. Each of the surfaces that act as protection against the water of the rain. The panels are supported by each of the air-filled isobutylene structural compartments. The panel material is nylon fabric, selected for its properties of impermeability, strength, light weight, and suitability for allowing the printing of slogans, logos, and advertising with direct visual impact.

4. Intrados. Each of the rectangular surfaces that cover the isobutylene structure. They are formed by nylon fabric and run from one side of the umbrella to the opposite side, giving rise to interior spans having a shared centre under the surfaces of the panels, and are joined to these by nylon seams, holding and protecting the elastic inflatable isobutylene structure within.

5. Handle. Located in the centre of the umbrella, under the inflation nozzle. The material is nylon fabric with a seam stitched with thread on both sides for strength and attachment to the body of the umbrella.

6. Loops. Formed by rectangular pieces of nylon fabric measuring 5 x 1 cm arranged along the intrados, such that an elastic cord, adjustable so as to fit the concave shape of the umbrella, may be passed through each one, thereby supplying additional support, holding power, and stability to keep the shape against the wind.

7. Elastic cord with a cord tension adjustment device.

8. Bag. A small spherical nylon bag with an opening to hold the inflatable umbrella.

Embodiment 2:

[0005] An elastomeric material such as latex and polyvinyl chloride (PVC).

[0006] This umbrella is formed from seven parts.

1. Nozzle. Air is blown into the interior in order to open and give shape to the structure of the umbrella by means of an opening or nozzle made of polyvinyl chloride (PVC) with a cap attached to the valve itself.

2. Structure. Formed by elastic compartments (at least six) made of polyvinyl chloride (PVC), circular in section and variable in length for holding the air previously pumped in through the PVC nozzle, such that the umbrella opens and in this way is able to support the panels, acting as the umbrella's ribs.

3. Panels. Each of the surfaces that act as protection against the water of the rain. The panels support each other and are joined to each of the air-filled PVC structural compartments by heat or heat welding. The panel material is PVC (like that used in pool air mattresses), selected for its properties of impermeability, strength, light weight, and suitability for allowing the printing of slogans, logos, and advertising with direct visual impact.

4. Handle. Located in the centre of the umbrella, under the inflation nozzle. The material is PVC attached to the body of the umbrella by heat welding of both surfaces or members.

5. Loops. Formed by rectangular pieces of PVC measuring 5 x 1 cm arranged along the intrados, such that an elastic cord, adjustable so as to fit the concave shape of the umbrella, may be passed through each one, thereby supplying additional support, holding power, and stability to keep the shape against the wind.

6. Elastic cord with a cord tension adjustment device.

7. Bag. A small spherical PVC bag with an opening to hold the inflatable umbrella.

Purpose of the invention

[0007] To be able to keep dry from the rain using this invention. Its great advantage is the extremely small space that it takes up and its rapid system for inflation and deflation for opening and closing.

Brief description of the drawings

[0008]

Fig. 1. sets out the set of all views of the inflatable

umbrella made of isobutylene and nylon.

Fig. 1 a. depicts an elevation view of the inflatable umbrella.

Fig. 1 b. depicts a top view of the inflatable umbrella.

Fig. 1c. depicts a bottom view of the inflatable umbrella.

Fig. 1d. depicts the inflatable umbrella folded up and stored in its bag.

Fig. 1e. depicts an expanded detail view of the tube for blowing air into the inflatable umbrella.

Fig. 2. sets out the set of all views of the inflatable umbrella made of an elastomeric material such as latex and polyvinyl chloride (PVC).

Fig. 2a. depicts an elevation view of the inflatable umbrella.

Fig. 2b. depicts a top view of the inflatable umbrella.

Fig. 2c. depicts a bottom view of the inflatable umbrella.

Fig. 2d. depicts the inflatable umbrella folded up and stored in its bag.

Fig. 2e. depicts an expanded detail view of the tube for blowing air into the inflatable umbrella.

Fig. 3. depicts assembly of the inflatable umbrella made of isobutylene and nylon.

Fig. 4. depicts assembly of the inflatable umbrella made of an elastomeric material such as latex and polyvinyl chloride (PVC).

Preferred embodiment of the invention

[0009] There follows a description of a specific instance of the umbrella according to this invention in reference to the attached drawings.

- Polyvinyl chloride (PVC) nozzle (5) or opening with a cap attached to the valve itself for blowing air into the inside.
- Structure (2) formed by at least six elastic compartments made of polyvinyl chloride (PVC) or isobutylene, being circular in section with an approximate resting diameter of 1 cm (empty of air) and a variable length of approximately 52 cm for holding the air previously pumped in through the PVC nozzle (5).
- Panels (1). Each surface acts as protection against the water of the rain. The panels are supported by

each of the air-filled isobutylene structural compartments (2) or the PVC compartments (10). The panel material is nylon fabric (1) or polyvinyl chloride (PVC) (6), selected for their properties of impermeability, strength, and light weight.

- Intrados (3). Each of the rectangular surfaces that cover the isobutylene structure (2). They are employed when nylon has been used to make the panels (1). They are made of nylon fabric and run from one side of the umbrella to the opposite side, giving rise to interior spans having a shared centre under the surfaces of the panels (1), and are joined to these by nylon seams, holding and protecting the inflatable elastic isobutylene structure (2) within.
- Handle (4). Located in the centre of the umbrella, under the inflation nozzle. The material is nylon fabric if nylon has been used to make the panels (1), with a seam stitched with thread on both sides for strength and attachment to the body of the umbrella, or of polyvinyl chloride (PVC) if PVC has been used for the panels (1).
- Loops (13) formed by rectangular pieces of nylon fabric or PVC, according to the material chosen to make the panels, measuring 5 x 1 cm arranged along the intrados, such that an elastic cord (11), adjustable so as to fit the concave shape of the umbrella, may be passed through each one, thereby supplying additional support, holding power, and stability to keep the shape against the wind.
- Elastic cord (11) with a cord tension adjustment device (12).
- Bag (8). A small spherical PVC or nylon bag, according to the material used to make the panels (1), with an opening to hold the inflatable umbrella, wherein the folded umbrella occupies the space of a sphere 7 cm in diameter.

Embodiment 1. Materials: isobutylene and nylon.

[0010] An inflatable umbrella optionally made of isobutylene and nylon. Characterised in that it includes the following elements:

The inflatable umbrella, deflated inside its nylon bag (8), occupies a spherical space approximately 7 cm in diameter. It is operated by removing it from the bag and blowing air in through the PVC nozzle (5) located at the top, whereby the said air expands through the entire length of each of the isobutylene tubes (2) measuring between 1 and 3 cm in diameter (empty and filled with air, respectively) and approximately 52 cm in length, thereby giving rise to concentric spokes from a single point, the inflation nozzle (5), and acting as ribs for the umbrella, in this way holding its structure erect and supporting the nylon panels (1) to protect against the water of the rain, mounted along the inflatable elastic structure (2).

[0011] Each tube is covered by the nylon panels (1) above and by a fabric (3) of the same material and quality as the panels below, i.e., nylon, 52 cm in length by 6 cm in width, approximately, by way of an intrados, to protect the elastic material. The panels (1) above and the fabric or intrados (3) below are joined together by a seam stitched with thread so as to leave a hollow to house and protect the air tubes.

[0012] Each intrados (3) is provided with a series of loops (13) made of rectangular pieces of nylon measuring 5 x 1 cm arranged along the intrados, such that an elastic cord (11), adjustable so as to fit the concave shape of the umbrella, may be passed through each one, thereby supplying additional support, holding power, and stability to keep the shape against the wind. The said cord is provided with a cord tension adjustment device (12).

[0013] Lastly, a handle (4) made of nylon fabric measuring 10 cm in length by 2 cm in width is positioned in the centre, under the umbrella, attached by a seam stitched with thread, by which the umbrella may be held.

Embodiment 2. Materials: polyvinyl chloride (PVC).

[0014] An inflatable umbrella optionally made of polyvinyl chloride. Characterised in that it includes the following elements:

The inflatable umbrella, deflated inside its PVC bag (8), occupies a spherical space approximately 7 cm in diameter. It is operated by removing it from the bag and blowing air in through the PVC nozzle (5) located at the top, whereby the said air expands through the entire length of each of the seven PVC tubes (10) measuring 1 cm in diameter (deflated) and approximately 52 cm in length, thereby giving rise to concentric spokes from a single point, the inflation nozzle (5), and acting as ribs for the umbrella, in this way holding its structure erect and supporting the PVC panels (6) to protect against the water of the rain, mounted along the inflatable elastic structure (2).

[0015] Each tube is covered by the PVC panels (1) above. The panels (1) and the air tubes are joined together by heat welding of the two members, the panels and the tubes.

[0016] In parallel, each PVC tube is provided with a series of loops (13) made of rectangular pieces of PVC measuring 5 x 1 cm and arranged along the length of each tube, such that an elastic cord (11), adjustable so as to fit the concave shape of the umbrella, may be passed through each one, thereby supplying additional support, holding power, and stability to keep the shape against the wind. The said cord is provided with a cord tension adjustment device (12).

[0017] Lastly, a handle (4) made of PVC fabric measuring 10 cm in length by 2 cm in width is positioned in the centre, under the umbrella, attached by a seam

stitched with thread, making it possible to hold the umbrella.

Industrial applicability

[0018] The subject matter of this utility model, namely, this inflatable umbrella, will be manufactured using materials that are suitable for its elements and components, i.e., polyvinyl chloride (PVC), isobutylene, and nylon.

Claims

1. Inflatable umbrella **characterised in that** it includes the following elements:

- Nozzle (5) or opening with a cap attached to the valve itself for blowing air into the inside.
- Structure formed by at least six elastic compartments, circular in section and with a variable length, which hold the air previously blown in through the nozzle (5).
- Panels. Each surface acts as protection against the water of the rain. The panels are supported by each of the air-filled structural compartments.
- Handle. Positioned at the centre of the umbrella, under the inflation nozzle.
- Loops formed by rectangular pieces and arranged such that an elastic cord (11), adjustable so as to fit the concave shape of the umbrella, may be passed through each one, thereby supplying additional support, holding power, and stability to keep the shape against the wind.
- Elastic cord (11) with a cord tension adjustment device (12).
- Bag. A small spherical bag with an opening to hold the inflatable umbrella, wherein the folded umbrella occupies the space of a sphere.

2. Inflatable umbrella according to claim 1, **characterised in that** it has a structure made of isobutylene, nylon panels, intradoses, namely, each of the rectangular surfaces covering the isobutylene structure, being made of nylon fabric and running from one side of the umbrella to the opposite side, giving rise to interior spans having a shared centre under the inflatable elastic isobutylene surface within; a nylon handle with a seam stitched in thread on either side for strength and attachment to the body of the umbrella; nylon loops arranged along the intrados; and a nylon bag.

3. Inflatable umbrella according to claim 1, **characterised in that** it has a structure made of polyvinyl chloride (PVC), PVC panels, PVC loops arranged along the structure, and a PVC bag.

4. Inflatable umbrella according to any preceding claim **characterised in that** the nozzle is made of PVC.
5. Inflatable umbrella according to any preceding claim **characterised in that** the resting diameter (empty of air) of the structure formed by at least six elastic compartments is 1 cm. 5
6. Inflatable umbrella according to any preceding claim **characterised in that** the length of the structure formed by at least six elastic compartments is approximately 52 cm. 10
7. Inflatable umbrella according to any preceding claim **characterised in that** the loops formed by rectangular pieces measure 5 cm x 1 cm. 15
8. Inflatable umbrella according to any preceding claim **characterised in that** the folded umbrella occupies the space of a sphere 7 cm in diameter in the small spherical bag. 20

25

30

35

40

45

50

55

fig 2

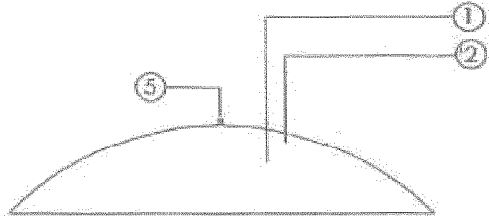
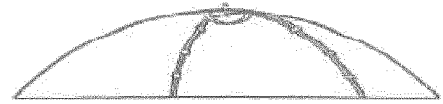

fig. 2a



SECTION A-A'

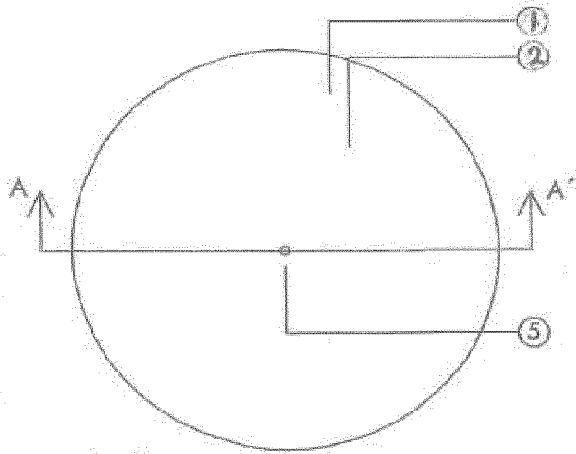

fig. 2b



fig. 2d

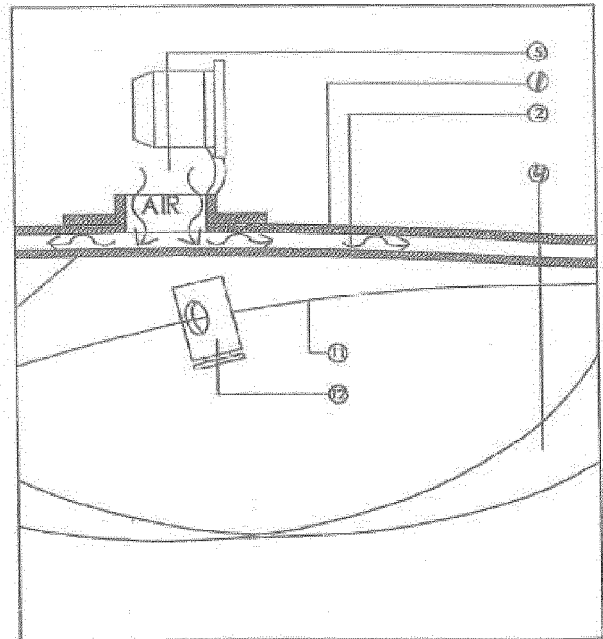

fig.2e

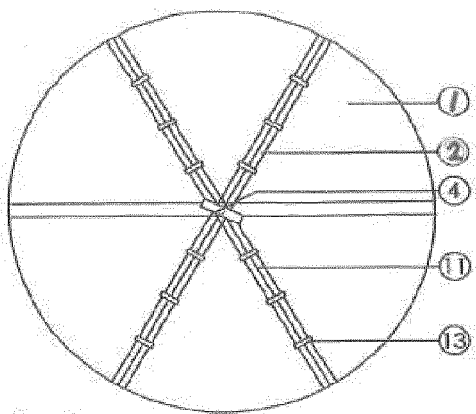
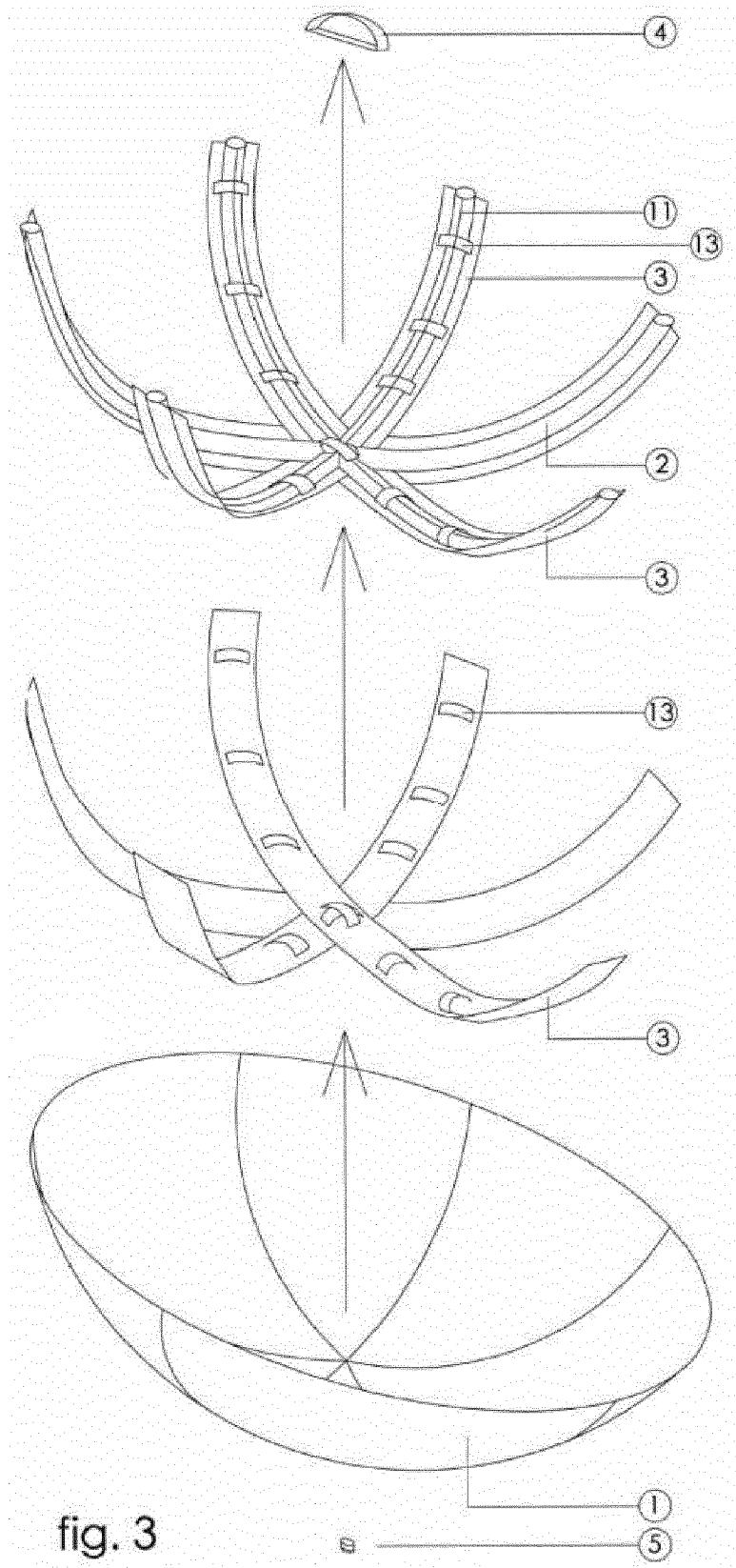
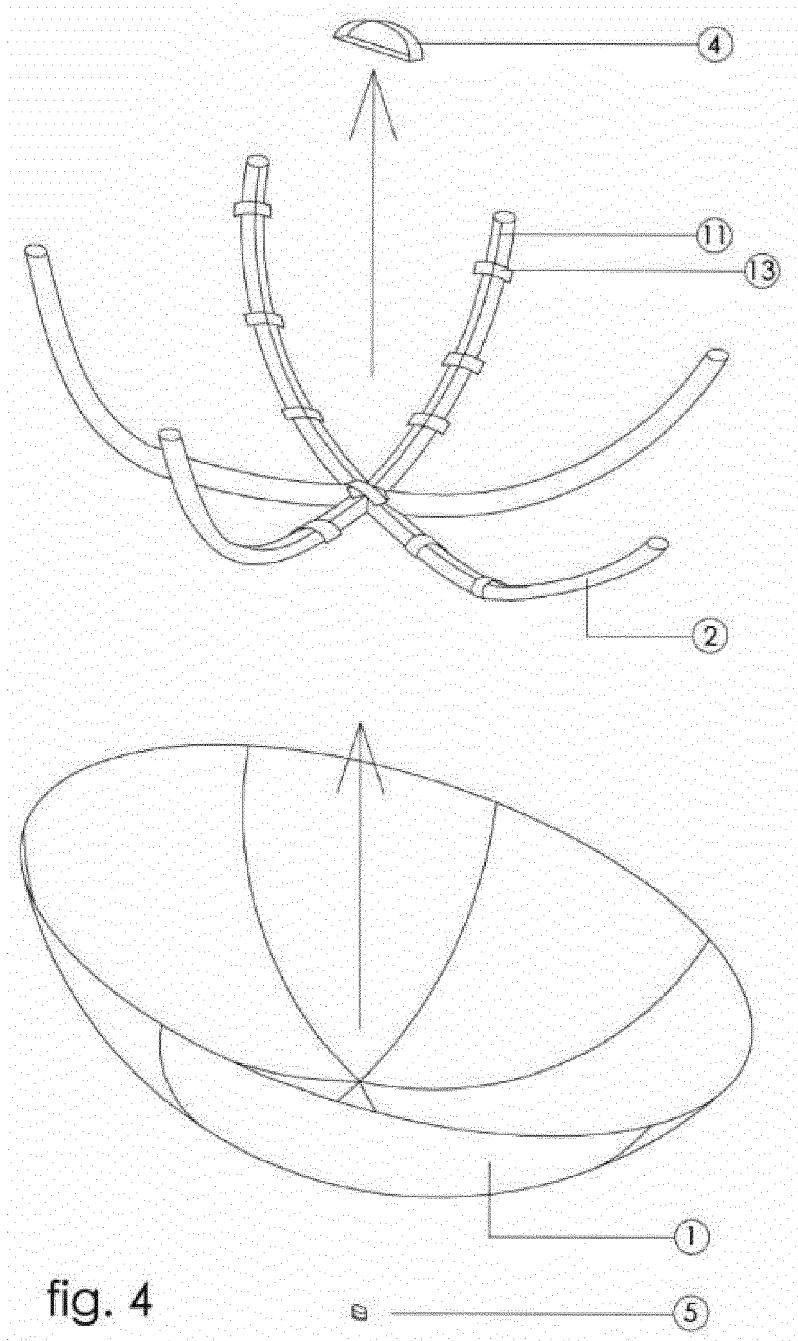

fig. 2c







EUROPEAN SEARCH REPORT

Application Number
EP 17 38 2426

5

10

15

20

25

30

35

40

45

50

55

DOCUMENTS CONSIDERED TO BE RELEVANT			
Category	Citation of document with indication, where appropriate, of relevant passages	Relevant to claim	CLASSIFICATION OF THE APPLICATION (IPC)
X	US 4 370 994 A (PITTMAN BENNY R [US]) 1 February 1983 (1983-02-01)	1,3-8	INV. A45B19/02
A	* column 3, line 1 - column 5, line 21 * * figures *	2	
A	----- JP S51 13961 U (-) 31 January 1976 (1976-01-31) * figures *	1-8	
A	----- WO 99/38412 A2 (U M B TECH LTD [IL]; KELNER MOSHE [IL]) 5 August 1999 (1999-08-05) * the whole document *	1-8	
A	----- CN 205 082 826 U (FAN JIAMING) 16 March 2016 (2016-03-16) * the whole document *	1-8	
The present search report has been drawn up for all claims			TECHNICAL FIELDS SEARCHED (IPC)
			A45B
Place of search		Date of completion of the search	Examiner
The Hague		23 October 2017	Frank, Lucia
CATEGORY OF CITED DOCUMENTS			
X : particularly relevant if taken alone		T : theory or principle underlying the invention	
Y : particularly relevant if combined with another document of the same category		E : earlier patent document, but published on, or after the filing date	
A : technological background		D : document cited in the application	
O : non-written disclosure		L : document cited for other reasons	
P : intermediate document		& : member of the same patent family, corresponding document	

EPO FORM 1503 03.02 (P04C01)

**ANNEX TO THE EUROPEAN SEARCH REPORT
ON EUROPEAN PATENT APPLICATION NO.**

EP 17 38 2426

5 This annex lists the patent family members relating to the patent documents cited in the above-mentioned European search report.
The members are as contained in the European Patent Office EDP file on
The European Patent Office is in no way liable for these particulars which are merely given for the purpose of information.

23-10-2017

Patent document cited in search report	Publication date	Patent family member(s)	Publication date
US 4370994 A	01-02-1983	NONE	
JP S5113961 U	31-01-1976	NONE	
WO 9938412 A2	05-08-1999	AU 2297199 A WO 9938412 A2	16-08-1999 05-08-1999
CN 205082826 U	16-03-2016	NONE	

EPO FORM P0459

For more details about this annex : see Official Journal of the European Patent Office, No. 12/82

REFERENCES CITED IN THE DESCRIPTION

This list of references cited by the applicant is for the reader's convenience only. It does not form part of the European patent document. Even though great care has been taken in compiling the references, errors or omissions cannot be excluded and the EPO disclaims all liability in this regard.

Patent documents cited in the description

- ES 0151845 U [0002]
- ES 0151845 Y [0002]
- DE 1967K062574 [0002]
- ES 0168316 U [0002]
- ES 0168316 Y [0002]
- DE 19702022515 [0002]
- ES 0371584 A1 [0002]
- DE 19681782611 [0002]
- ES 0008589 U [0002]
- ES 0357093 A1 [0002]
- DE 19671632514 [0002]
- ES 2532718 T3 [0002]
- EP 2686080 A1 [0002]
- EP 2686080 B1 [0002]
- WO 2012123747 A [0002]
- GB 20110004442 A [0002]
- GB 2012050568 W [0002]
- ES 0337738 A1 [0002]
- DE 1966086863 B [0002]
- ES 0181364 U [0002]
- ES 0181364 Y [0002]
- DE 19712129265 [0002]
- ES 0289626 A1 [0002]
- DE X289626 [0002]
- ES 0307222 A1 [0002]
- DE X307222 [0002]
- ES 0296545 A1 [0002]