

May 16, 1967

C. J. DARGENE

3,319,934

HINGE ADJUSTING TOOL

Filed April 6, 1965

2 Sheets-Sheet 1

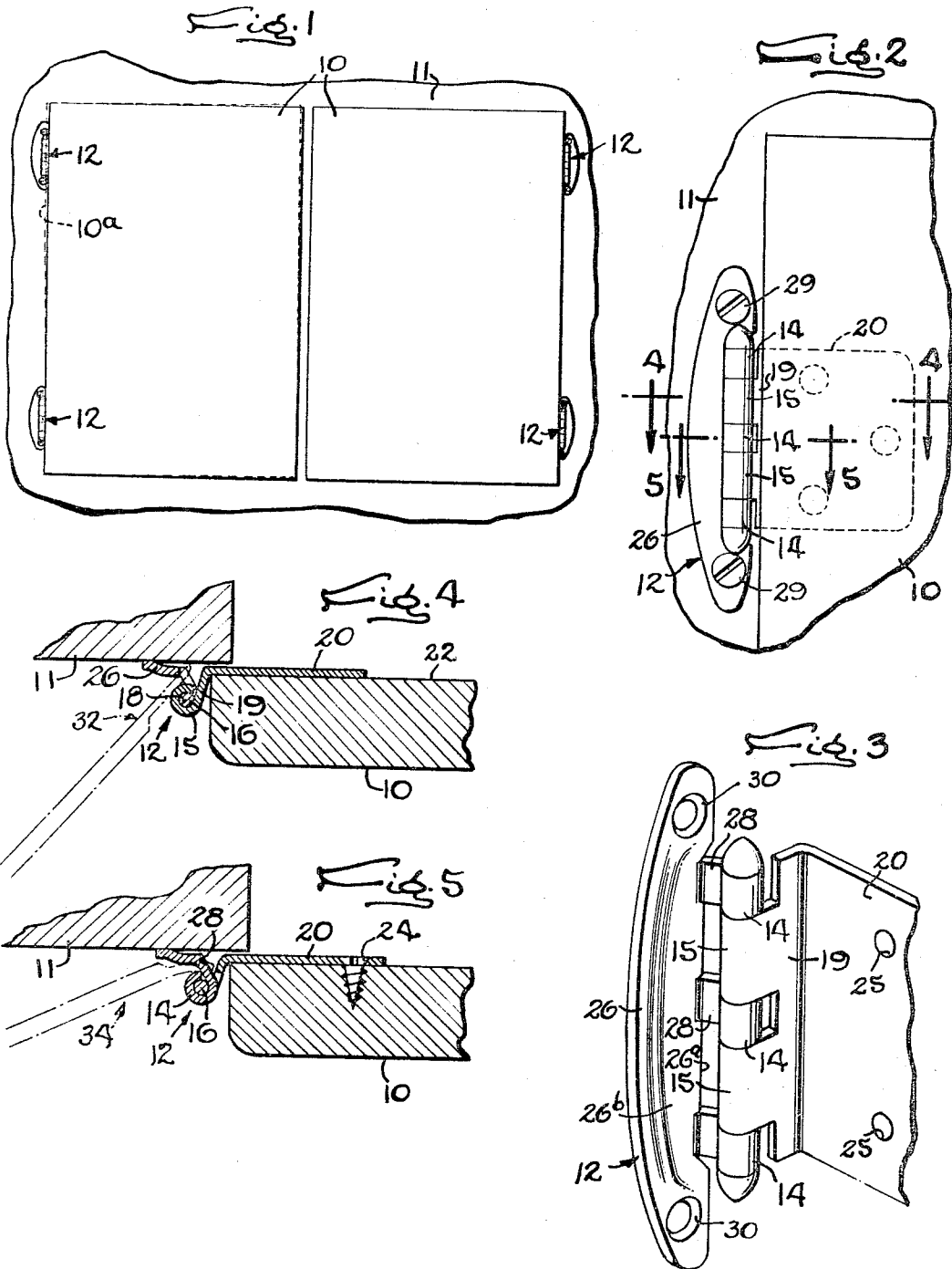

INVENTOR
Carl J. Dargene
by Wolfe, Hubbard, Vest & Osborn
ATTORNEY

May 16, 1967

C. J. DARGENE

3,319,934

HINGE ADJUSTING TOOL

Filed April 6, 1965

2 Sheets-Sheet 2

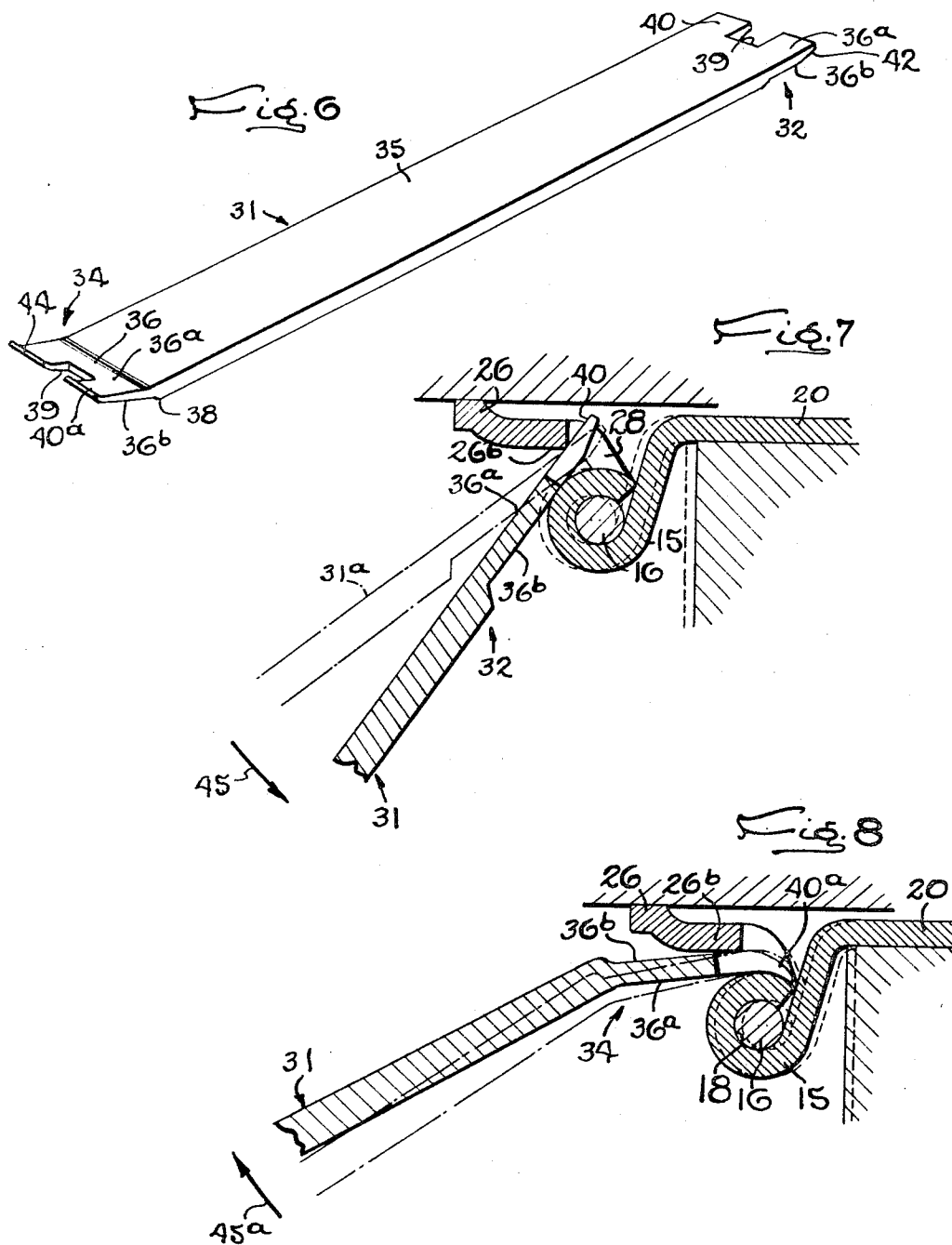

INVENTOR
Carl J. Dargene
by Wolfe, Hubbard, Vait & Osann
ATTORNEY

1

3,319,934

HINGE ADJUSTING TOOL

Carl J. Dargene, Rockford, Ill., assignor to Amerock Corporation, Rockford, Ill., a corporation of Illinois
 Filed Apr. 6, 1965, Ser. No. 445,955
 2 Claims. (Cl. 254-131)

This invention relates to a hinge adjusting tool, and more particularly to a tool for bending a hinge which is pivotally supporting a door, to aline the door with the supporting frame.

An object of this invention is to make possible the accurate alinement of the door by providing a tool for impressing a force on the hinge sufficient to bend the hinge flanges and move the door laterally with respect to the frame.

Other objects and advantages of the invention will become apparent from the following detailed description taken in connection with the accompanying drawings, in which

FIGURE 1 is a fragmentary front view of a pair of doors pivotally supported on a frame by hinges.

FIG. 2 is an enlarged fragmentary view of the upper corner of the left hand door of FIG. 1 showing the hinge and a portion of the supporting frame.

FIG. 3 is a fragmentary enlarged view of a commonly used cabinet hinge.

FIG. 4 is a fragmentary cross-sectional view taken along the line 4-4 of FIG. 2 showing the tool in broken lines inserted to correct the door positioning to the right.

FIG. 5 is a fragmentary cross-sectional view taken along the line 5-5 of FIG. 2 showing the tool in broken lines inserted to correct the door positioning to the left.

FIG. 6 is an enlarged perspective view of an implement having a tool at each end for adjusting a hinge.

FIG. 7 is a fragmentary enlarged view of a hinge similar to that of FIG. 3 showing the tool and hinge movement to correct the door positioning to the right.

FIG. 8 is a fragmentary enlarged view of a hinge similar to that of FIG. 3 showing the tool and hinge movement to correct the door positioning to the left.

To illustrate the invention, a pair of doors 10 are shown in FIG. 1 pivotally supported from a frame 11 by hinges 12. The hinges are made of sheet metal and include interfitting curls 14 and 15 (FIGS. 2 through 5) pivotally attached by a pivot pin 16 extending through aligned openings 18 (see FIGS. 4, 5) in the curls and centered on the hinge pivot axis. The hinge is made of a ductile material, such as sheet metal, and the door supporting curls 15 are formed by bending the free ends of door flanges 19 back on themselves. These door flanges are formed integrally with a door leaf 20 which is bent at an angle to extend around the door edge and lie flat against the back face 22 of the door. The door leaf is attached to the door by flat head screws 24 passing through countersunk holes 25 in the door leaf and driven into the back face of the door. The frame supported curls 14 are formed by the bent ends of frame flanges 28 extending from an edge 26a, adjacent the door, of frame leaf 26. The flanges are bent to extend outwardly from the frame leaf with a center portion 26b on the frame leaf raised to space the edge 26a from the frame. The frame leaf is fastened to the frame by flat head screws 29 passing through countersunk holes 30 in the leaf and driven into the frame.

After the door is mounted on the frame by attaching the hinges in the manner just described, it frequently does not aline exactly with the frame or with other adjacent doors. The problem stems from the difficulty of holding and alining the door while positioning the hinges, where even a slight variance in the hinge position makes a much

2

larger difference in the position of the extended end of the door. Since most hinges are made of bendable sheet metal, the most frequent method of alining the door, where the misalinement is slight, is to bend one or both hinges to reposition the door with respect to the frame. Where hinges of the general type just described are used, this is difficult since the sheet material of the hinge is substantially same thickness throughout and may bend in any of a number of places. It is also desirable not to change the spacing between the door and curls as would occur if the door flanges are bent, since this is quite noticeable when the door is closed.

In accordance with the present invention, a tool is provided for accurately alining a door on a frame by impressing a force only between the frame leaf and the hinge curls sufficient to bend the frame flanges and reposition the door on the frame. The tool may take the form of one to force the hinge curls laterally towards the frame leaf to bend the frame flange in the same direction or one to force the hinge curls laterally away from the frame leaf for bending the frame flange in that direction, for a like change in the door position. In either form, the tool includes a member which may be inserted between the frame leaf and curls of a mounted hinge with a first abutment for contacting the frame leaf and a second abutment for contacting the hinge curls such that, by moving an attached handle to pivot this member either towards or away from the hinge curls, the frame supported flange can be bent to reposition the door laterally on the frame.

In FIG. 6 is shown an elongated implement 31 having a tool 32 and a tool 34 attached to a handle 35 at opposite ends, with either tool suitable for adjusting a hinge of the type described but one tool specifically formed to bend the frame flanges in one direction, and the other specifically formed to bend the hinge flanges in the other. The tools each include a rigid flat wedge member 36 having flat surfaces 36a and 36b and being sufficiently thin to fit flatwise between the curls and frame leaf of the hinge to be adjusted. The wedge member is preferably rectangular and attaches to the handle along one edge. In the embodiment shown the handle and wedge member are formed of one elongated piece with the wedge member machined to a lesser thickness than the handle forming an offset 38 at the juncture therebetween. A notch 39 is cut in the edge of the wedge member opposite to the handle forming a pair of parallel spaced fingers 40. The notch is wide enough to span a frame flange 28. The fingers include a beveled surface 42 adjacent to and forming a tip 44 of lesser thickness on the extending end of each finger making it easier to insert the tool into the hinge. The unbeveled flat surface 40a on the fingers form a first abutment while the flat surface 36b on the opposite side of the wedge member and spaced laterally from the surface 40a forms a second abutment for contacting the hinge.

To describe the tool 32 for bending the hinge flanges away from the frame leaf, assume the door on the left in FIG. 1, after being hung, is out of alinement as shown by the dotted lines 10a and must be shifted to the solid line position. To shift the door from this position the upper left hand hinge must be adjusted to the right. As shown in FIGS. 4 and 7, the tool 32 of the implement 31 is inserted into the hinge with the surface 36a towards the frame leaf and the tool in the position 31a (see FIG. 7) with the fingers 40 extending to either side of the center flange 28 and the edge 36b of the wedge member adjacent this flange. The handle is then pivoted in the direction of arrow 45 to force the surface 36a on the fingers against the raised edge 26b of frame leaf adjacent the door and from which the frame supported flanges extend, and force

3

the surface 36b on the wedge member against the hinge. The wedge member and handle serves as a lever to multiply the force exerted on the handle and move the curls to the right as the handle is pivoted further in the direction of arrow 45. The force is exerted against the frame leaf and distributed across the curls to bend the frame flanges and reposition the curls and supported door to the right in FIG. 7. This bending of the flanges preferably takes place while the door is closed, permitting observation of the alinement of the door with the frame and other door.

Assume now the left hand door in FIG. 1 needs to be shifted to the left. The tool 34 is used for this purpose to exert a force between the curls and frame leaf for bending the frame flange in a direction to shift the curls and supported door to the left. As so far described, tool 34 is substantially like tool 32 with the addition that the first abutment or curl surface 40a may be shaped to conform slightly to the outer surface of the curls (see FIGS. 5 and 8) and the handle 35 is offset slightly from the plane of the wedge member 36 to prevent it from contacting the frame as the tool is pivoted. For bending the flanges 28 to shift the door towards the frame leaf, the tool 34 is inserted with the fingers straddling the center flange 28 but with the face 36a of the wedge member facing the curls. In this instance the tool is pivoted in the direction of arrow 45a (see FIG. 8) to bring the face 36a on the fingers against the underneath side of the curls and the face 36b on the wedge member against the raised portion 26b of the frame leaf. Further pivoting of the handle in this direction forces the curls to the left to bend the flanges 28 in the same direction about the frame leaf. The door is thus moved from the broken line position shown in FIG. 8. While the tool 34 functions the same as tool 32, the handle being offset from the plane of the wedge member prevents contact between the frame and handle as the tool is pivoted in the direction of arrow 45a. Also the cupped or ached surface 40a on the fingers assists in establishing a firm engagement with the curls for moving them to the left as the handle is pivoted.

Sometimes the hinge 12 is positioned close to a wall where it might be difficult to insert the tool as shown in FIG. 8. It has been found satisfactory in these instances, to open the door 10 and then insert the tool between the flange and curls from the direction of the door, i.e., from the right in FIG. 8 if the door were open. By pivoting the tool clockwise, i.e., towards the door, the curls and door can be moved to the left in the same manner as heretofore described.

I claim as my invention:

1. A hinge tool for adjusting a hinge pivotally supporting a door on a frame and including a frame leaf attached to the frame and supporting a plurality of spaced frame flanges extending to and supporting cylindrical shaped hinge curls, said tool comprising, a flat rigid wedge member having first and second flat surfaces facing opposite

4

and having a thickness therebetween less than the spacing between the frame leaf and curls, said wedge member including a plurality of parallel extending spaced fingers supported from one edge, said fingers being spaced apart a distance greater than the width of the frame flanges and positioned to extend therebetween, a first abutment including the first flat surface of said wedge member, a second abutment on the side of said fingers adjacent the second flat surface of said wedge member and shaped to fit the curved surface of the curls, a handle attached to the edge of said wedge member opposite said fingers and extending in the direction said first flat surface faces and at an acute angle with the plane of the wedge member, whereby said tool can be inserted in the hinge with the wedge member between the frame leaf and curls and the fingers extending between the frame flanges and a force applied on said handle to bring said first abutment into contact with the frame leaf and said second abutment into contact with said curls to bend the frame flanges and reposition the curls and door in a lateral direction towards the frame leaf.

2. A hinge tool for adjusting a hinge pivotally supporting a door on a frame and including a frame leaf attached to the frame and supporting on the edge adjacent the door a plurality of spaced frame flanges extending to and supporting hinge curls, said tool comprising a flat rigid wedge member having opposite facing flat surfaces and a thickness therebetween less than the spacing between the frame leaf and curls, said wedge member including a plurality of parallel spaced fingers supported from one edge and extending in the plane of said wedge member, said fingers being positioned to align with the spaces between the frame flanges when the wedge member is inserted between the frame leaf and curls, a first abutment on a first flat surface of said wedge member and laterally spaced from said fingers, a second abutment on said fingers adjacent the second flat surface of said wedge member, a handle attached to said wedge member, whereby by inserting said wedge member between the frame leaf and curls with said fingers straddling said frame flanges and moving said handle to bring said first and second abutments in contact with the curls and frame leaf edge respectively a force can be exerted therebetween to bend the frame flanges and adjust the position of the door away from the frame leaf.

References Cited by the Examiner

UNITED STATES PATENTS

1,309,734	7/1919	Hemfling	254—131
1,459,635	6/1923	Miller	29—219
1,559,976	1/1925	Ness	254—131
2,379,387	6/1945	Tessier	254—131
2,470,309	5/1949	Hepp	29—270

55 OTHELL M. SIMPSON, *Primary Examiner.*