



(11) **EP 1 795 665 A2**

(12) **EUROPEAN PATENT APPLICATION**

(43) Date of publication:
13.06.2007 Bulletin 2007/24

(51) Int Cl.:
E04B 2/96 (2006.01) E04D 3/08 (2006.01)

(21) Application number: **06025430.7**

(22) Date of filing: **08.12.2006**

(84) Designated Contracting States:
AT BE BG CH CY CZ DE DK EE ES FI FR GB GR HU IE IS IT LI LT LU LV MC NL PL PT RO SE SI SK TR
Designated Extension States:
AL BA HR MK YU

(71) Applicant: **Reynaers Aluminium, naamloze vennootschap**
2570 Duffel (BE)

(72) Inventor: **Martine Reynaers**
2570 Duffel (BE)

(30) Priority: **12.12.2005 BE 200500599**

(74) Representative: **Donné, Eddy**
Bureau M.F.J. Bockstael nv
Arenbergstraat 13
2000 Antwerpen (BE)

(54) **Improved T-joint**

(57) Improved T-joint to connect two struts (23 and 24) at right angles, which T-joint (1) is provided with a body (2) which can be provided in a strut (23) and with a pen (13) which can work in conjunction with an opening (27) in the other strut (24), which pen (13) can move in the body (2) between a rest position whereby the above-mentioned pen (13) is pushed out of a guide (9) and a pushed-in position whereby the pen (13) is provided with springy elements (20, 43) which can be provided through the above-mentioned opening (27) of a strut (24) to be mounted, and which can hook behind the walls (28) thereof.

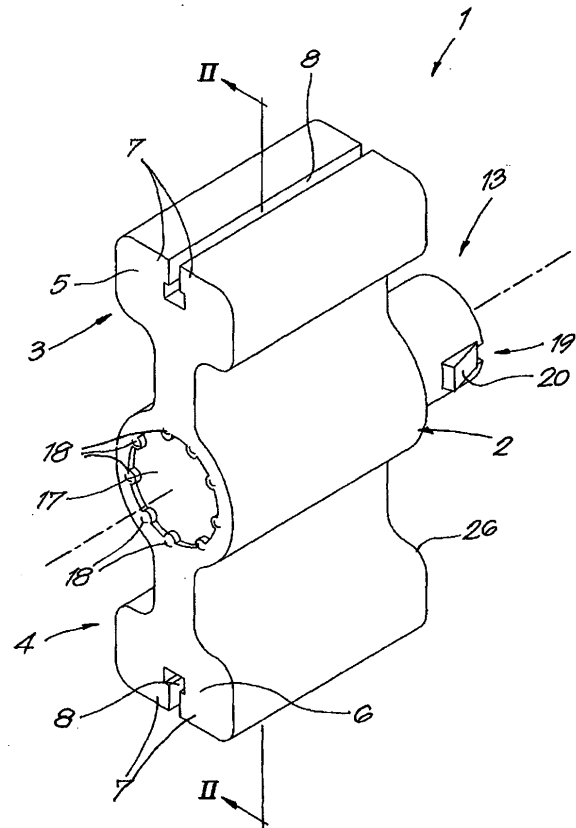

Fig. 1

EP 1 795 665 A2

Description

[0001] The present invention concerns an improved T-joint.

[0002] In particular, the invention concerns a T-joint of the type which is designed to connect two struts at right angles, which T-joint is mainly provided with a profiled body which can be axially provided in one of the above-mentioned struts, and with a pen which can work in conjunction with an opening in the other strut to be connected, which pen can axially move in a guide in the above-mentioned profiled body between an extreme rest position whereby the above-mentioned pen is pushed at least partly out of the guide by means of a spring and a pushed-in position.

[0003] From EP 1,020,575 is already known a T-joint whose pen is provided with two recesses near its free end, situated in two opposite sides of the pen respectively, and which provide for an anchorage in relation to the above-mentioned second strut.

[0004] Further, the pen of such a known T-joint is provided with fins which mesh in axially directed grooves which are provided in the wall of the above-mentioned guide of the profiled body, so as to prevent the pen from rotating round its longitudinal axis during an axial movement, since an incorrect assembly would otherwise be possible.

[0005] A major disadvantage of such a known T-joint is that its construction is relatively complex due to the presence of the different recesses, grooves and fins, which makes the construction of the parts very time-consuming and expensive.

[0006] Another disadvantage of such a known T-joint is that also the assembly is very time-consuming since, while the pen is being mounted in the body, the pen must be positioned correctly in relation to this body.

[0007] The present invention aims to remedy one or several of the above-mentioned and other disadvantages.

[0008] To this end, the present invention concerns a T-joint of the above-mentioned type, whereby the above-mentioned pen is provided with one or several springy elements on its free crosscut end which can be provided through the above-mentioned opening of a strut to be mounted and which can hook behind the walls of said strut.

[0009] An advantage of such an improved T-joint is that its construction is considerably simpler and thus cheaper than is the case with the existing T-joints.

[0010] Another advantage of such an improved T-joint according to the invention is that the orientation of the pen in relation to the body does not matter for the assembly, as a result of which the assembly can be carried out very quickly.

[0011] In order to better explain the characteristics of the present invention, the following preferred embodiments of an improved T-joint according to the invention are given as an example only, without being limitative in

any way, with reference to the accompanying drawings, in which:

figure 1 schematically represents an improved T-joint according to the invention;

figure 2 represents a section according to line II-II in figure 1;

figures 3 and 4 represent the method of construction of a part of a T-joint according to figure 1;

figure 5 schematically represents an assembly of two struts standing on each other by means of a T-joint according to figure 1, seen in perspective;

figure 6 represents a disassembled view of a part according to figure 5;

figure 7 represents a section according to line VII-VII in figure 6;

figure 8 represents a variant according to figure 1;

figure 9 represents a section according to line IX-IX in figure 8;

figure 10 represents the variant from figure 8 when assembled according to figure 2;

figure 11 represents another variant of a T-joint according to figure 1;

figure 12 represents a section according to line XII-XII in figure 11;

figures 13 and 14 represent the assembly of a part of a T-joint according to figure 11.

[0012] Figures 1 and 2 represent an improved T-joint 1 according to the invention which is provided with a profiled body 2 which is made for example but not necessarily of aluminium and which, in this case, is provided with two wings 3 and 4 on its outside which are provided, on their respective far ends 5 and 6, with two ribs 7 bent towards each other on their far ends so as to form longitudinal grooves 8.

[0013] In the above-mentioned body 2 is also provided a guide 9 in the form of a hole which extends through this body 2, in the axial direction X-X' of the profiled body 2.

[0014] The above-mentioned guide 9 has a step-like course in the axial direction, in other words it has a first part 10 with a diameter D1 and a second part 11 with a diameter D2 which is smaller than the above-mentioned first diameter D1, such that at the transition between these parts 10 and 11 a stop 12 is formed.

[0015] In the guide 9 is provided a pen 13 whose diameter is somewhat smaller than the above-mentioned diameter D2 and which is pushed along the first part 10 into the second part 11 of the guide 9 and which is provided with an outward directed collar 14 on one far end whose diameter is larger than the diameter D2 and which can be pushed up against the above-mentioned stop 12, such that, in this position, the pen 13 protrudes from the body 2 with a certain part having a length L on one far end of the guide 9.

[0016] The pen 13 is maintained in its extreme rest position by means of a spring 15 which is provided in a recess 16 in the pen 13 with one far end and which is

clamped by means of a cover plate 17 which covers the other far end of the guide 9 and which is fixed to the body 2.

[0017] In the given example, the cover plate 17 is fixed to the body 2 as the above-mentioned far end of the guide 9 is made with a somewhat larger diameter so as to form a shoulder on which the cover plate 17 rests and whereby the cover plate 17 is being kept in place by providing mechanical deformations 18 in the material of the body 2 round the cover plate 17.

[0018] Finally, according to the invention, the above-mentioned pen 13 is provided with one or several, in this case two springy elements 20 at its crosscut free end 19 which, in this case, but not necessarily, are part of an accessory 21 provided on said crosscut far end 19, which accessory 21 is made in the shape of a strip 22, preferably of a resilient material, such as for example stainless steel, and whereby the above-mentioned springy elements 20 are formed of the free ends of the strip 22 which are bent slantingly towards the body 2, as if it were to form a sort of barbs.

[0019] It is clear that, according to the invention, the above-mentioned springy elements 20 can also be made in the form of separate elements provided on the free ends of the above-mentioned strip 22.

[0020] As is represented in greater detail in figures 3 and 4, the above-mentioned strip 22 is in this case provided on the crosscut far end 19 of the above-mentioned pen 13 by means of a mechanical deformation of the material of this pen 13, but it is clear that it can be fixed in many other ways, such as for example by means of a wringing fit, gluing, screwing, snapping in, a locking pin or the like.

[0021] The use of an improved T-joint 1 according to the invention is represented in figures 5 to 7 and it is very simple and as follows.

[0022] In order to connect two struts 23 and 24 at right angles, the above-mentioned T-joint 1 is pushed in the strut 23 in the axial direction X-X', whereby ribs 25 on opposite walls on the inside of the strut 23 serve as guides which are held in the grooves 8 of the wings 3 and 4.

[0023] The T-joint 1 is hereby, with its pen 13 directed outward, pushed entirely in the strut 23 until the end face 26 coincides with the far end of the strut 23.

[0024] The T-joint 1 is subsequently locked in the strut 23 in the axial direction, for example by means of glue, screws or the like, not represented in the figures.

[0025] In order to subsequently provide for a connection between the struts 23 and 24, the pen 13 must be pushed in the guide 9 of the body 2 by exerting a force in the opposite sense of the force exerted on the pen 13 by the above-mentioned spring 16.

[0026] Since, in practice, the strut 23 will have to be provided between two struts 24 standing at right angles on the latter, an improved T-joint 1 according to the invention will have to be provided on the other far end of said strut 23 as well, which is not represented in the figures for clarity's sake and whose use is analogous to that

of the given T-joint 1.

[0027] As soon as the pen 13 has been pushed in entirely, the strut 23 can be pushed between two struts 24 until the pen 13, under the influence of the resilience, dashes into an opening 27 in the second strut 24.

[0028] As the above-mentioned springy elements 20 unfold as soon as the pen 13 has been pushed through the opening 27, they will hook behind the walls 28 of this second strut 24.

[0029] Thanks to its simple construction, an improved T-joint according to the invention can be assembled and mounted in a fast and simple manner, since the orientation of the pen 13 in relation to the body 2 does not matter.

[0030] Figures 8 to 10 represent a possible variant of an improved T-joint 1 according to the invention whereby the body 2, and in particular the wing 3, is made in two parts, with a first part 29 which is fixed in the strut 23 and a second part 30 which can move in relation to the above-mentioned first part 29 respectively.

[0031] Between the above-mentioned parts 29 and 30 are provided clamping means in the form of a conical threaded hole in which has been provided an adjusting screw 31 with a countersunk head 32.

[0032] In this embodiment of a T-joint 1, the respective wings 3 and 4 are not provided with ribs 7 bent towards each other.

[0033] The other wing 4 is made as an L-shaped profiled part 33 which, as represented in figure 10, is held between a rib 34 in the strut 23 and a wall 35 of this strut 23 when mounted.

[0034] The far end of wing 3 rests against a second rib 5 in the strut 23, whereas the mobile part 30 is provided against the above-mentioned wall 35 of this strut 23.

[0035] In order to prevent an axial movement of the T-joint 1, the adjusting screw 31 is tightened, such that the part 30 is pushed away from the part 29 and the body 2 is clamped between the rib 36 and the wall 35.

[0036] The pen 13 is provided with a shank 37 and protrudes from the body 2 with the springy elements 20 on one far end, whereas the shank 37 protrudes from the other far end.

[0037] Near its free end, the above-mentioned shank 37 is provided with locking means 38 which prevent an axial movement in one direction and which in particular form a stop to the axial movement of the pen 13 under the influence of the spring 15.

[0038] In this case, the above-mentioned locking means 38 are formed of a locking ring 39 provided in a circumferential groove 40 in the above-mentioned rear end of the pen 13.

[0039] Preferably, but not necessarily, the locking means 38 can be adjusted, for example since one or several circumferential grooves 41 are provided, such that the above-mentioned locking ring 39 can also be provided in other grooves, depending on whether a sealing is either or not used between the struts 23 and 24.

[0040] Finally, figures 11 and 12 represent another embodiment of an improved T-joint 1 according to the in-

vention, whereby the above-mentioned accessory 21 is made in the shape of a ring 42 of a resilient material, such as for example stainless steel, which in this case has two springy wings 43 as springy elements and which, as represented in greater detail in figures 13 and 14, is pushed over a protrusion 44 on the crosscut far end of the pen 13 and which is locked by the mechanical deformation of said protrusion 44 after the accessory 21 has been provided.

[0041] It is clear that the above-mentioned accessory 21 can be made in all sorts of materials which preferably but not necessarily have some resilience, such as for example plastic, spring steel or the like.

[0042] According to the invention, the above-mentioned springy elements can be made in one piece with the above-mentioned accessory 21 or with the pen 13, or they can be made as separate thereof.

[0043] The present invention is by no means restricted to the embodiments given as an example and represented in the accompanying drawings; on the contrary, such an improved T-joint according to the invention can be made in all sorts of shapes and dimensions while still remaining within the scope of the invention.

Claims

1. Improved T-joint to connect two struts (23 and 24) at right angles, which T-joint (1) is mainly provided with a profiled body (2) which can be axially provided in one of the above-mentioned struts (23), and with a pen (13) which can work in conjunction with an opening (27) in the other strut (24) to be connected, which pen (13) can be axially moved in a guide (9) in the above-mentioned profiled body (2) between an extreme rest position whereby the above-mentioned pen (13) is pushed at least partly out of the guide (9) by means of a spring (15) and a pushed-in position, **characterised in that** the above-mentioned pen (13) is provided with one or several springy elements (20, 43) on its free crosscut far end (19) which can be provided through the above-mentioned opening (27) of a strut (24) to be mounted and which can hook behind the walls (28) of said strut (24).
2. Improved T-joint according to claim 1, **characterised in that** the above-mentioned guide (9) is formed of a hole in the body (2), whereby this guide (9) is sealed on one side by means of a cover plate (17).
3. Improved T-joint according to claim 1, **characterised in that** the above-mentioned guide (9) is formed of a hole which extends through the body (2) and **in that** the above-mentioned pen (13) is provided with a shank (37), such that the above-mentioned pen (13) with the springy elements (20) protrudes from the body (2) on one side, whereas the shank (37) protrudes from the body (2) on the other side.
4. Improved T-joint according to claim 3, **characterised in that** the above-mentioned shank (37) is provided with locking means (38) near its free end which prevent an axial movement of the pen (13) in one direction and which in particular form a stop to the axial movement of the pen (13) under the influence of the above-mentioned spring (15).
5. Improved T-joint according to claim 4, **characterised in that** the above-mentioned locking means (38) can be adjusted.
6. Improved T-joint according to claim 4 or 5, **characterised in that** the above-mentioned locking means (38) consist of a locking ring (39) provided in a circumferential groove (40 or 41) of the above-mentioned pen (13).
7. Improved T-joint according to claim 1, **characterised in that** the above-mentioned springy elements (20) are provided on or are part of an accessory (21) provided on the crosscut far end (19) of the above-mentioned pen (13).
8. Improved T-joint according to claim 7, **characterised in that** the above-mentioned accessory (21) is made of a springy material.
9. Improved T-joint according to claim 7, **characterised in that** the above-mentioned accessory (21) is provided on the crosscut free end (19) of the above-mentioned pen (13) in at least one of the following ways: a mechanical deformation, a wringing fit, gluing, screwing, snapping in, a locking pin or the like.
10. Improved T-joint according to claim 7, **characterised in that** the above-mentioned accessory (21) is formed of a strip (22) which is provided on the crosscut far end (19) of the above-mentioned pen (13) and whereby the springy elements (20) are formed of the free ends of this strip (22) which are bent slantingly towards the body (2) or **in that** the springy elements are provided on the free ends of this strip (22).
11. Improved T-joint according to one or several of the preceding claims, **characterised in that** it is provided with clamping means for axially clamping the T-joint in a strut (23) to be connected.
12. Improved T-joint according to claim 11, **characterised in that** the body (2) is made in two parts, with a first part (29) which is fixed in a strut (23) to be mounted and a second part (30) which can move in relation to the above-mentioned first part (29) respectively, and **in that** the above-mentioned clamping means are made in the form of a conical threaded

hole provided between the above-mentioned parts (29 and 30) and in which is provided an adjusting screw (31).

5

10

15

20

25

30

35

40

45

50

55

5

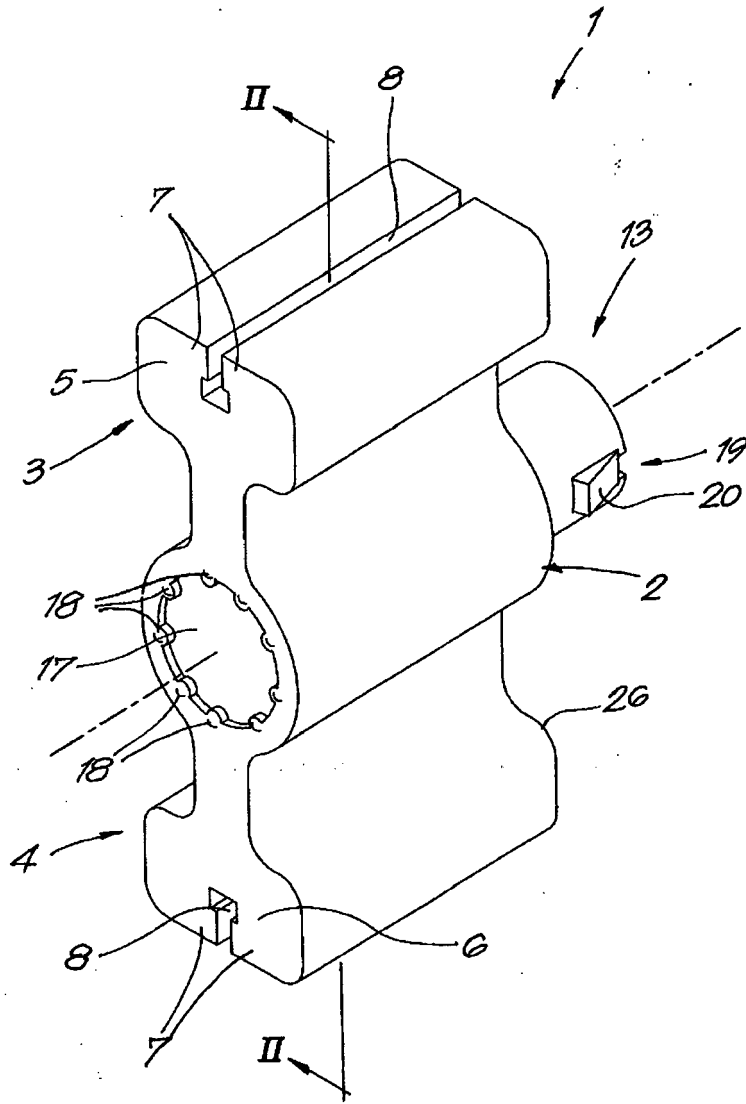

Fig. 1

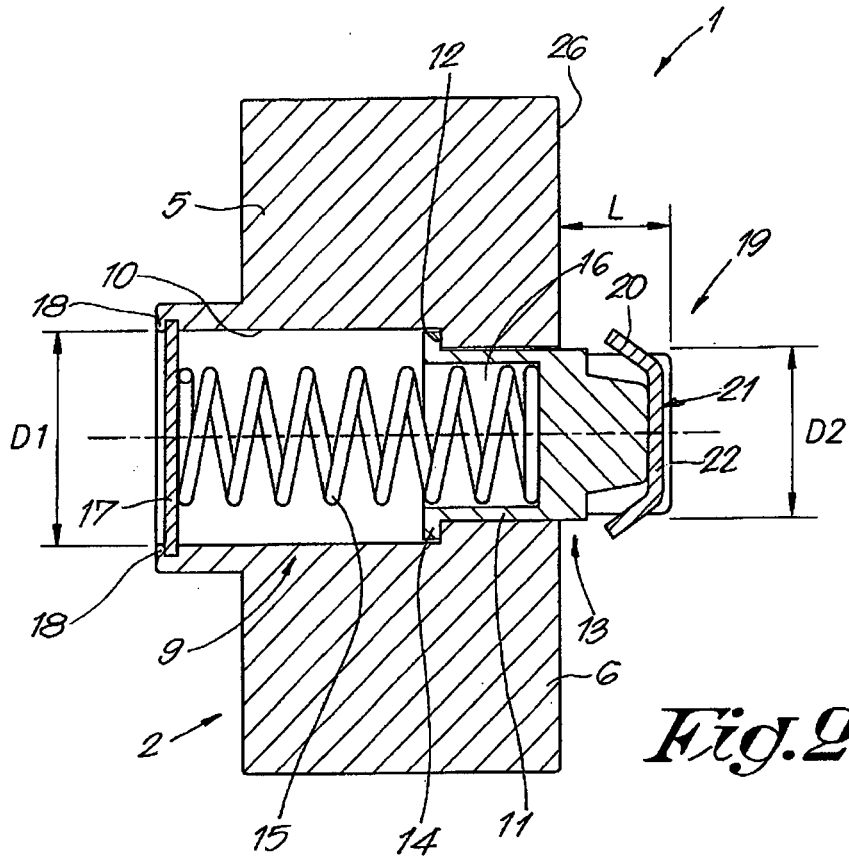

Fig. 2

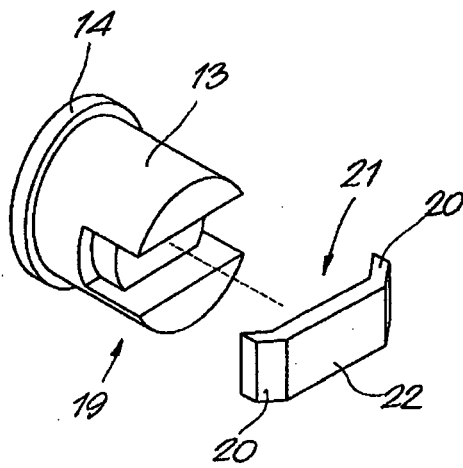

Fig. 3

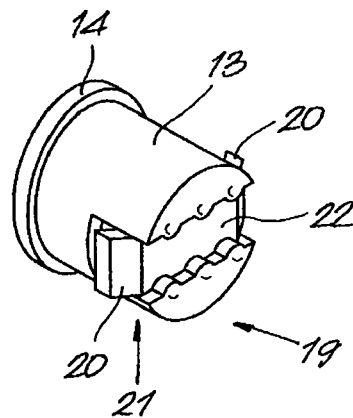

Fig. 4

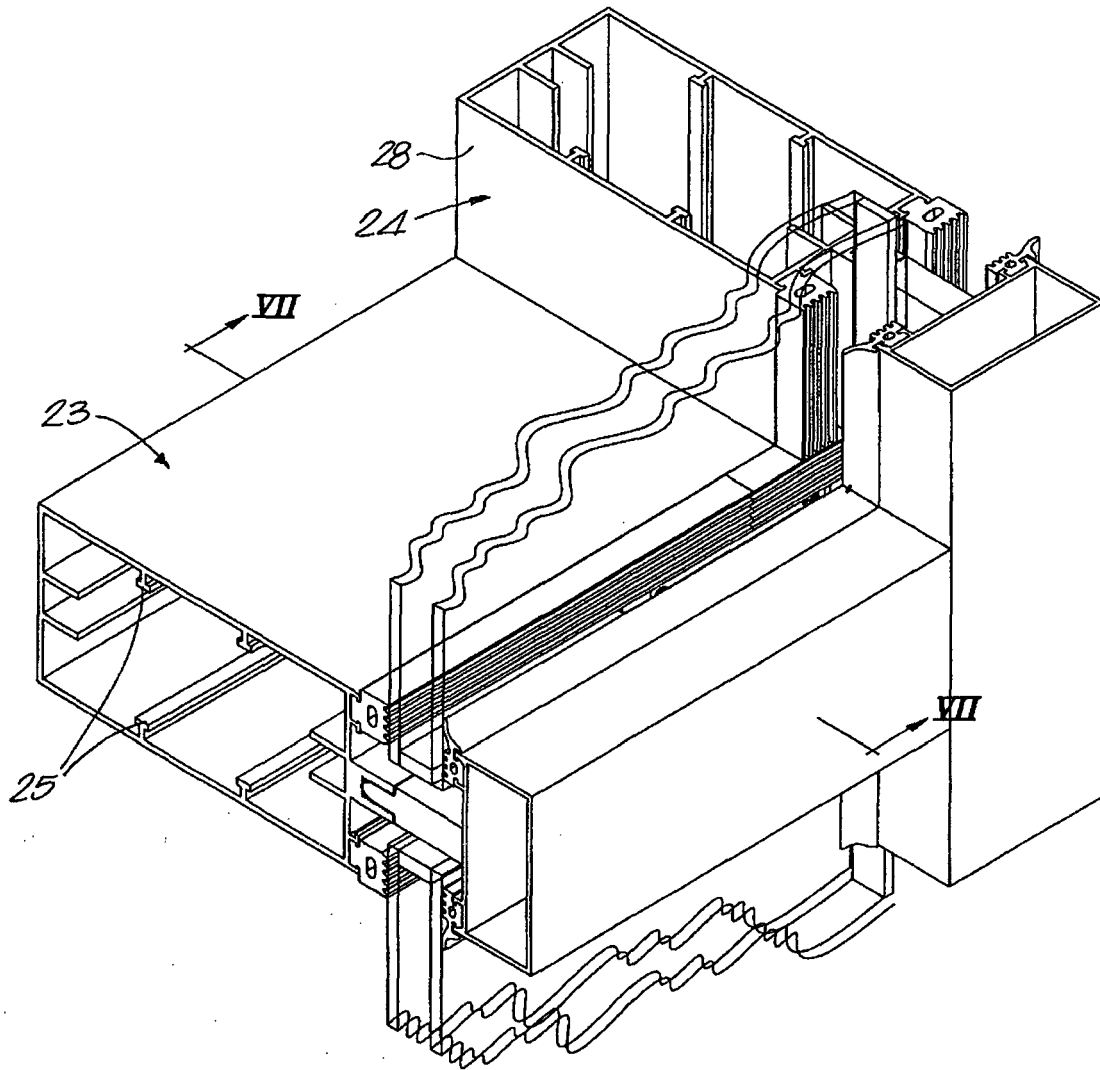
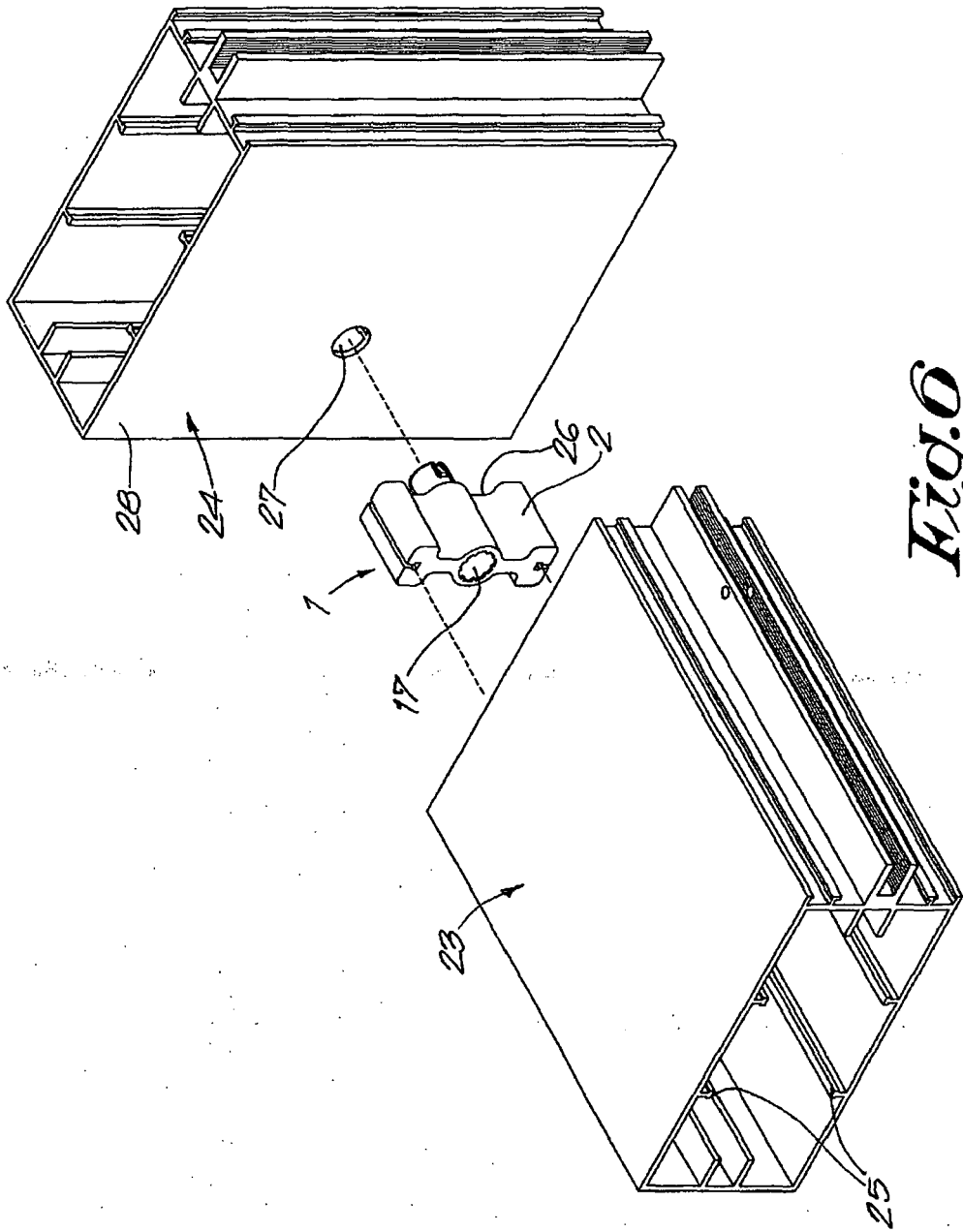

Fig.5



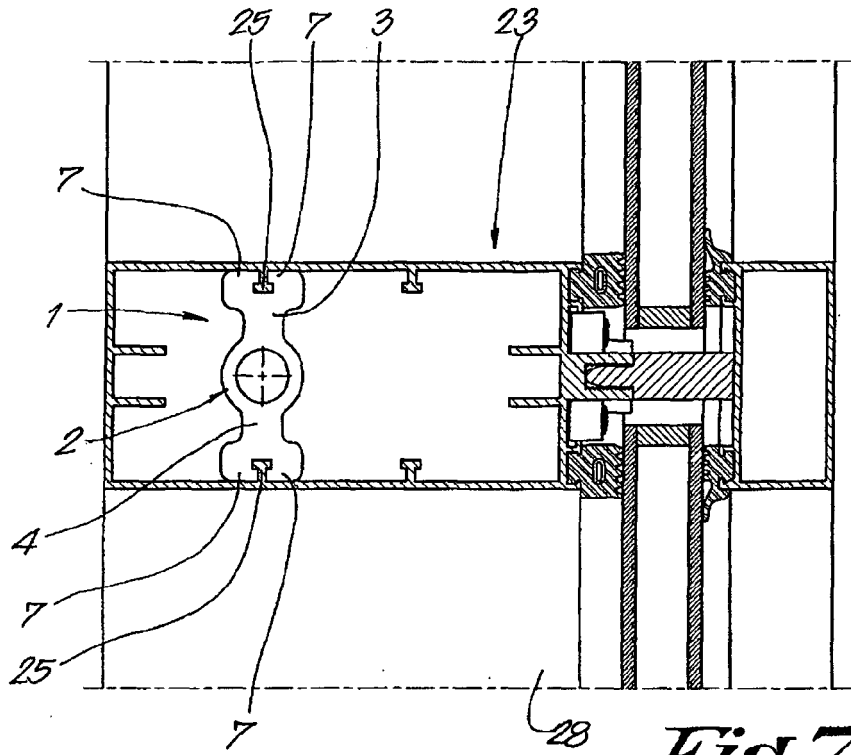

Fig.7

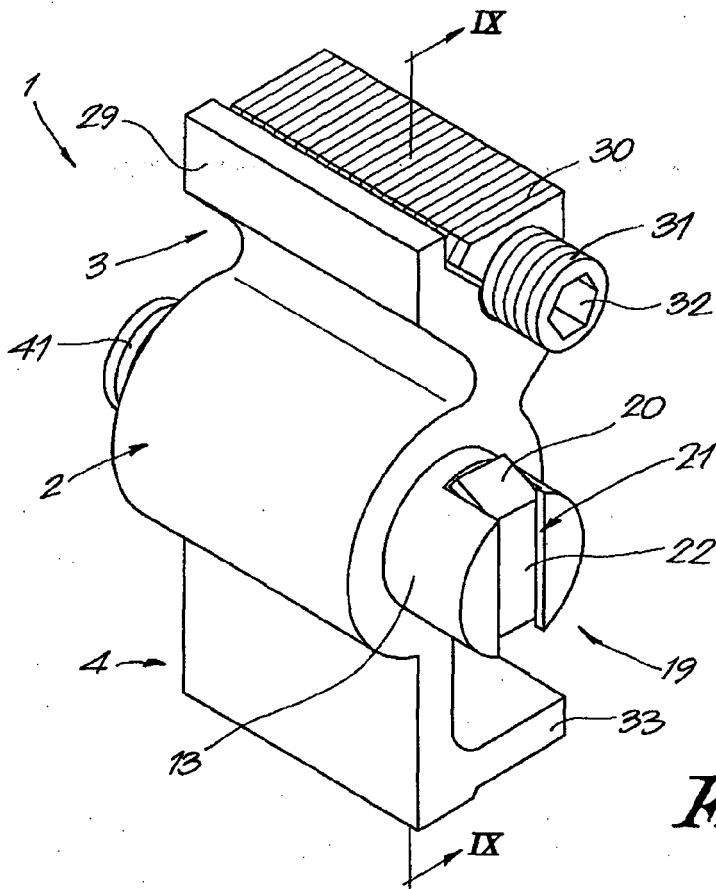
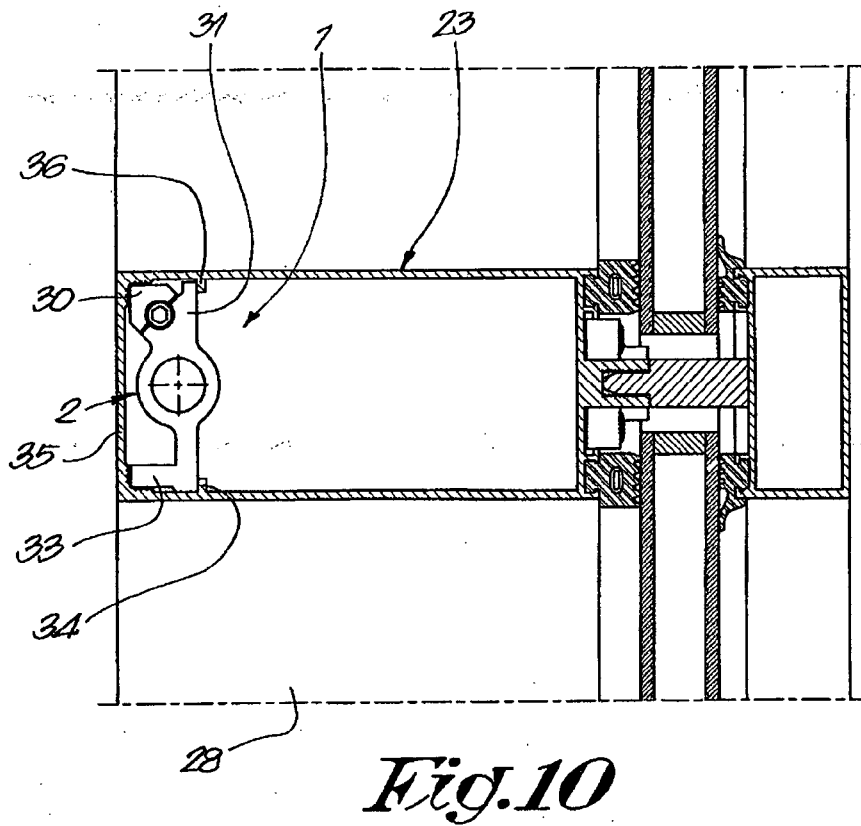
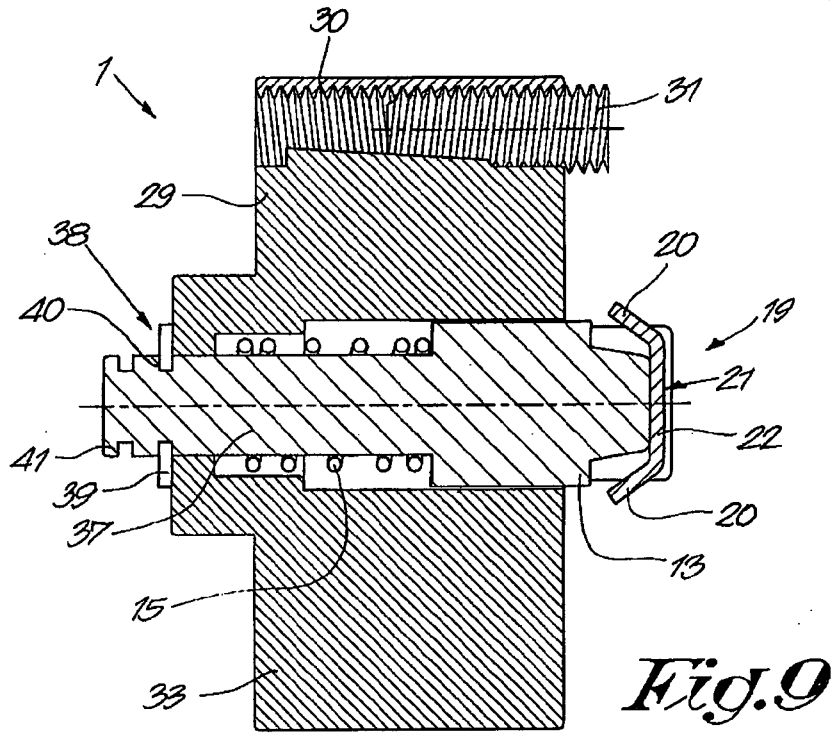

Fig.8



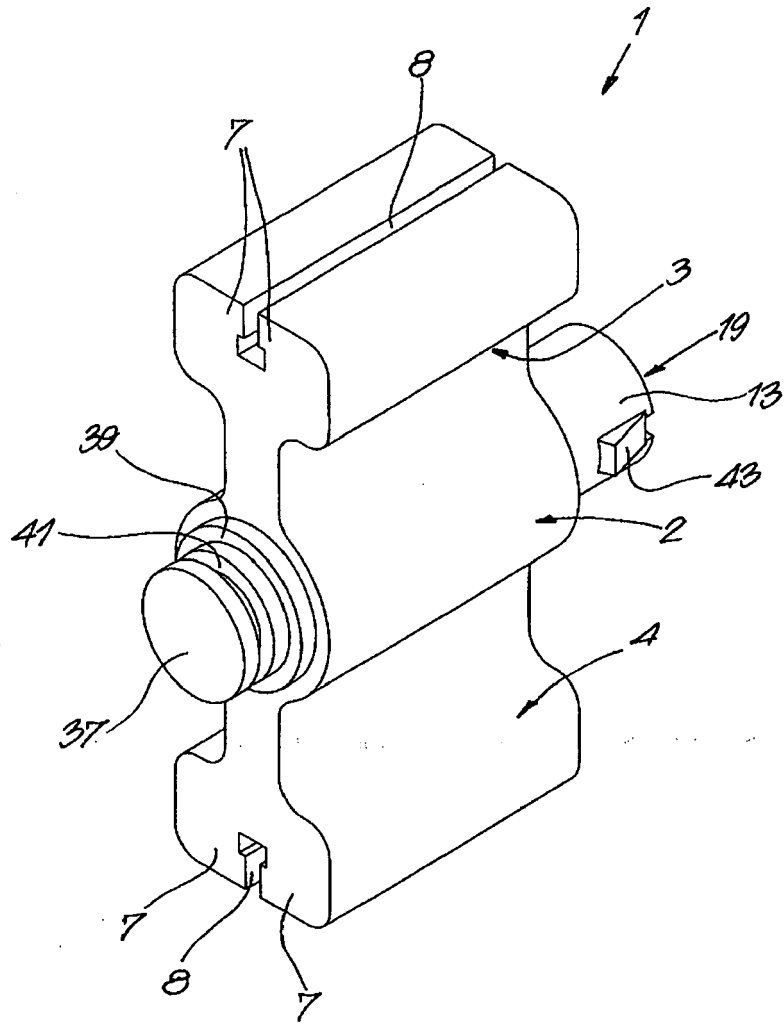

Fig.11

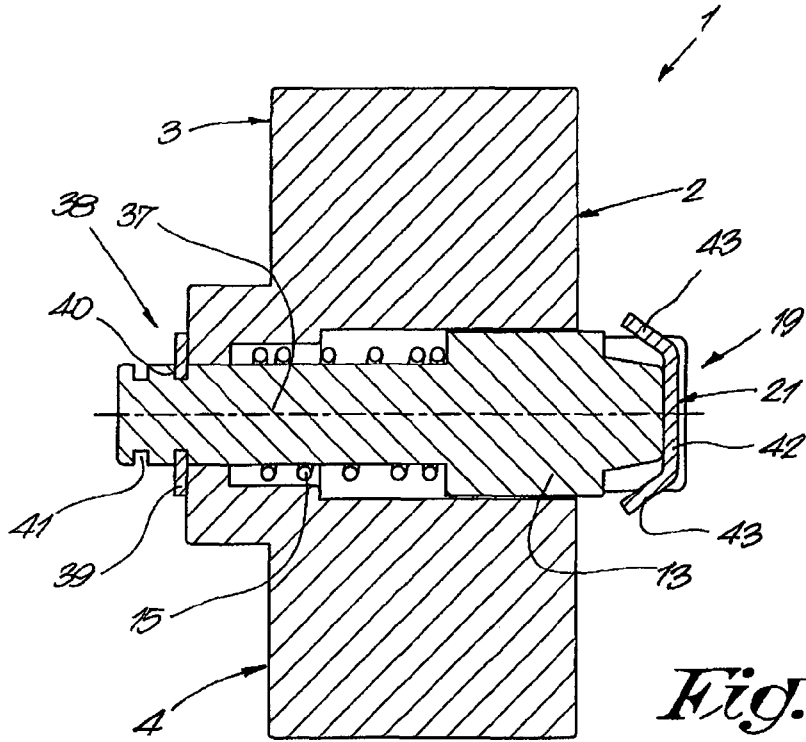

Fig. 12

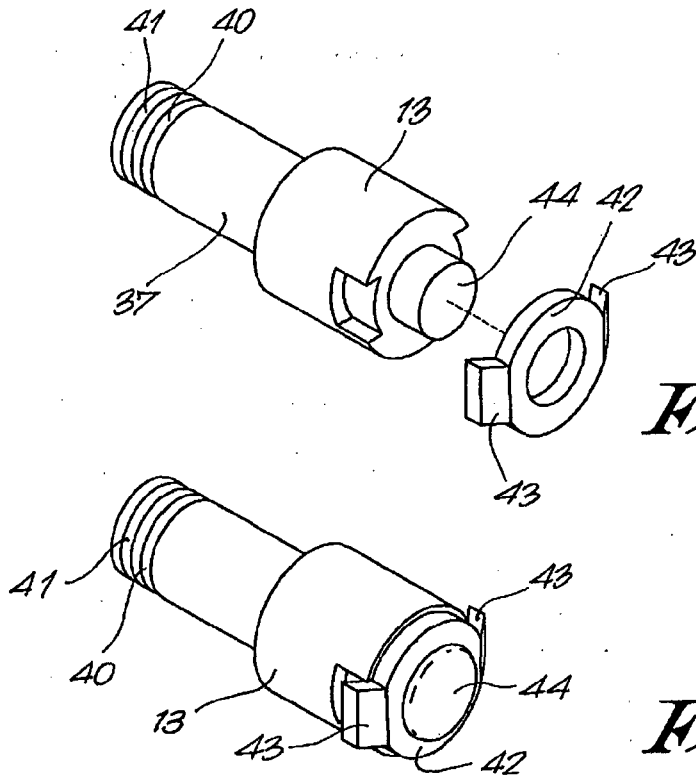

Fig. 13

Fig. 14

REFERENCES CITED IN THE DESCRIPTION

This list of references cited by the applicant is for the reader's convenience only. It does not form part of the European patent document. Even though great care has been taken in compiling the references, errors or omissions cannot be excluded and the EPO disclaims all liability in this regard.

Patent documents cited in the description

- EP 1020575 A [0003]