

(19) World Intellectual Property Organization
International Bureau



(43) International Publication Date
18 August 2011 (18.08.2011)

PCT

(10) International Publication Number
WO 2011/100528 A2

(51) International Patent Classification:
A61K 38/00 (2006.01)

(21) International Application Number:
PCT/US2011/024497

(22) International Filing Date:
11 February 2011 (11.02.2011)

(25) Filing Language: English

(26) Publication Language: English

(30) Priority Data:
61/303,733 12 February 2010 (12.02.2010) US

(71) Applicant (for all designated States except US):
EMORY UNIVERSITY [US/US]; Office of Technology
Transfer, 1599 Clifton Road NE, 4th Floor, Atlanta, GA
30322 (US).

(72) Inventors; and

(75) Inventors/Applicants (for US only): CUMMINGS,
Richard, D. [US/US]; 1832 Grist Stone Court, Atlanta,
GA 30307 (US). STOWELL, Sean, R. [US/US]; 200
Henton Park Drive, Decatur, GA 30030 (US). ARTHUR,
Connie [US/US]; 513 Tuxworth Circle, Decatur, GA
30033 (US).

(74) Agents: MASON, James, C. et al.; Emory University,
Office of Technology Transfer, 1599 Clifton Road NE,
4th Floor, Atlanta, GA 30322 (US).

(81) Designated States (unless otherwise indicated, for every
kind of national protection available): AE, AG, AL, AM,
AO, AT, AU, AZ, BA, BB, BG, BH, BR, BW, BY, BZ,
CA, CH, CL, CN, CO, CR, CU, CZ, DE, DK, DM, DO,
DZ, EC, EE, EG, ES, FI, GB, GD, GE, GH, GM, GT,
HN, HR, HU, ID, IL, IN, IS, JP, KE, KG, KM, KN, KP,
KR, KZ, LA, LC, LK, LR, LS, LT, LU, LY, MA, MD,
ME, MG, MK, MN, MW, MX, MY, MZ, NA, NG, NI,
NO, NZ, OM, PE, PG, PH, PL, PT, RO, RS, RU, SC, SD,
SE, SG, SK, SL, SM, ST, SV, SY, TH, TJ, TM, TN, TR,
TT, TZ, UA, UG, US, UZ, VC, VN, ZA, ZM, ZW.

(84) Designated States (unless otherwise indicated, for every
kind of regional protection available): ARIPO (BW, GH,
GM, KE, LR, LS, MW, MZ, NA, SD, SL, SZ, TZ, UG,
ZM, ZW), Eurasian (AM, AZ, BY, KG, KZ, MD, RU, TJ,
TM), European (AL, AT, BE, BG, CH, CY, CZ, DE, DK,
EE, ES, FI, FR, GB, GR, HR, HU, IE, IS, IT, LT, LU,
LV, MC, MK, MT, NL, NO, PL, PT, RO, RS, SE, SI, SK,
SM, TR), OAPI (BF, BJ, CF, CG, CI, CM, GA, GN, GQ,
GW, ML, MR, NE, SN, TD, TG).

Declarations under Rule 4.17:

— as to applicant's entitlement to apply for and be granted
a patent (Rule 4.17(ii))

Published:

— without international search report and to be republished
upon receipt of that report (Rule 48.2(g))



WO 2011/100528 A2

(54) Title: COMPOSITIONS AND USES OF LECTINS

(57) Abstract: The disclosure relates to uses of a purified or isolated lectin to kill bacteria, viruses, and other pathogens. In certain embodiments, the disclosure relates to method of treating or preventing an infection comprising administering a purified or isolated galectin to a subject in need thereof. In certain embodiments, the subject is at risk of, exhibiting symptoms of, or diagnosed with a pathogenic infection.

COMPOSITIONS AND USES OF LECTINS

This application claims priority to U.S. Provisional Application No. 61,303,733 filed February 12, 2010 hereby incorporated by reference.

BACKGROUND

Blood type is a classification of blood based on the presence or absence of inherited antigenic substances on the exterior surface of red blood cells. The A and B antigens have trisaccharide structures [A, GalNAc α 1-3(Fuc α 1-2)Gal β 1; and B, Gal α 1-3(Fuc α 1-2)Gal β 1] attached to a variety of glycolipids and glycoproteins on the erythrocyte (red blood cell) surface. Group O individuals lack the terminal glycosyltransferases necessary to produce the A or B antigens and carry the disaccharide H antigen (Fuc α 1-2Gal β 1).

Recent studies suggest that blood group antigen diversity may provide a mechanism of pathogen evasion whereby distinct ABO(H) antigen structures may reduce pathogen attachment and therefore infectivity. Because ABO(H) antigens are composed of carbohydrate structures that only differ by distinct monosaccharides on the terminal structures of glycans, factors that might be responsible for providing innate immunity toward pathogens expressing blood group antigens should recognize carbohydrates.

Bacteria generate a wide variety of glycan-based antigenic structures, many of which can possess blood group antigen activity. For example, *E. coli* O86 cross-reacts with antibodies specific for human blood group B and induces high titers of blood group B-specific antibodies in previously unexposed individuals. Notably, whereas individuals of blood group A or O produce antibodies that kill *E. coli* O86, individuals with blood group B do not generate antibodies capable of altering *E. coli* O86 viability, providing a specific example of the immunological limitation in adaptive immunity toward a blood group antigen-bearing pathogen. Springer & Horton, *J. Clin. Invest.* 48, 1280-1291 (1969) and see also Vasta, *Nat. Rev. Microbiol.* 7, 424-438 (2009) entitled "Roles of galectins in infection."

SUMMARY

The disclosure relates to uses of a purified or isolated lectin to kill bacteria, viruses, and other pathogens. In certain embodiments, the disclosure relates to method of treating or

preventing an infection comprising administering a purified or isolated lectin to a subject in need thereof. In certain embodiments, the subject is at risk of, exhibiting symptoms of, or diagnosed with a pathogenic infection.

In certain embodiments, the subject is a human subject. In certain embodiments, the lectin is a galectin such as Gal-4, Gal-8, Gal-7, Gal-9 or active fragments thereof provided the galectin comprises a C-terminal carbohydrate recognition domain. Typically, the C-terminal carbohydrate recognition domain or variant thereof is the human C-terminal carbohydrate recognition domain. In certain embodiments, the fragment of Gal-4, Gal-8, and Gal-9 comprises a C-terminal carbohydrate recognition domain. In certain embodiments, the fragment of Gal-9 comprises an N-terminal carbohydrate recognition domain.

In certain embodiments, the disclosure relates to pharmaceutical compositions comprising a galectin such as Gal-4, Gal-8, Gal-7, Gal-9 or fragments thereof. Typically, the galectin comprises a C-terminal carbohydrate recognition domain. In certain embodiments, the disclosure relates to uses of a Gal-4, Gal-8, Gal-7, Gal-9 or fragments thereof provided the galectin comprises a C-terminal carbohydrate recognition domain in the production of a medicament for the treatment or prevention of a pathogenic infection.

In certain embodiments, the subject is diagnosed with blood type B.

In certain embodiments, the pathogen, such as bacteria, virus, or fungus, express a human blood group antigen comprising a carbohydrate on the exterior of the pathogen. Typically, the human blood group antigen is A, B, H, an Rh glycoprotein or combination thereof.

For example, in a particular embodiment, the subject is at risk of, exhibiting symptoms of, or diagnosed with a bacterial infection selected from the group consisting of *Acinetobacter baumannii*, *Bordetella pertussis*, *Burkholderia cepacia*, *Burkholderia pseudomallei*, *Burkholderia mallei*, *Campylobacter jejuni*, *Campylobacter coli*, *Enterobacter cloacae*, *Enterobacter aerogenes*, *Escherichia coli*, *Francisella tularensis*, *Haemophilus influenzae*, *Haemophilus ducreyi*, *Helicobacter pylori*, *Klebsiella pneumoniae*, *Legionella pneumophila*, *Moraxella catarrhalis*, *Morganella morganii*, *Neisseria gonorrhoeae*, *Neisseria meningitidis*, *Pasteurella multocida*, *Proteus mirabilis*, *Proteus vulgaris*, *Pseudomonas aeruginosa*, *Salmonella typhi*, *Serratia marcescens*, *Shigella flexneri*, *Shigella boydii*, *Shigella sonnei*, *Shigella dysenteriae*, *Stenotrophomonas maltophilia*, *Vibrio cholerae*, and *Chlamydia pneumoniae*. In certain embodiments, the bacterium is a gram-negative.

In certain embodiments, the purified or isolated galectin is administered in combination with one or more additional/second antibiotic agents. Typically, the second antibiotic is sulfanilamide, sulfamethizole, sulfamethoxazole, sulfapyridine, trimethoprim, pyrimethamine, nalidixic acids, norfloxacin, ciproflaxin, cinoxacin, dapsone, enoxacin, gatifloxacin, gemifloxacin, grepafloxacin, levofloxacin, lomefloxacin, moxifloxacin, ofloxacin, pefloxacin, sparfloxacin, trovafloxacin, penicillins (amoxicillin, ampicillin, azlocillin, carbenicillin, cloxacillin, dicloxacillin, flucloxacillin, hetacillin, oxacillin, mezlocillin, penicillin G, penicillin V, piperacillin), cephalosporins (cefacetrile, cefadroxil, cefalexin, cefaloglycin, cefalonium, cefaloridin, cefalotin, cefapirin, cefatrizine, cefazafur, cefazedone, cefazolin, cefradine, cefroxadine, ceftazolidime, cefaclor, cefonicid, ceforanide, cefprozil, cefuroxime, cefuzonam, cefmetazole, cefoteta, cefoxitin, cefcapene, cefdaloxime, cefdinir, cefditoren, cefetamet, cefixime, cefmenoxime, cefodizime, cefoperazone, cefotaxime, cefotiam, cefpimizole, cefpiramide, cefpodoxime, cefteteram, ceftibuten, ceftiofur, ceftiolen, ceftizoxime, ceftriaxone, cefoperazone, ceftazidime, cefepime), moxolactam, carbapenems (imipenem, ertapenem, meropenem) monobactams (aztreonam) oxytetracycline, chlortetracycline, clomocycline, demeclocycline, tetracycline, doxycycline, lymecycline, meclocycline, methacycline, minocycline, rolitetracycline, chloramphenicol, amikacin, gentamicin, framycetin, kanamycin, neomicin, neomycin, netilmicin, streptomycin, tobramycin, azithromycin, clarithromycin, dirithromycin, erythromycin, roxithromycin, telithromycin, polymyxin-B, colistin, bacitracin, tyrothricin, nitrofurantoin, furazolidone, metronidazole, tinidazole, Isoniazid, pyrazinamide, ethionamide, nystatin, amphotericin-B, hamycin, miconazole, clotrimazole, ketoconazole, fluconazole, rifampacin, lincomycin, clindamycin, spectinomycin, chloramphenicol, clindamycin, colistin, fosfomicin, loracarbef, metronidazole, nitrofurantoin, polymyxin B, polymyxin B sulfate, procain, spectinomycin, tinidazole, trimethoprim, ramoplanin, teicoplanin, vancomycin, trimethoprim, sulfamethoxazole, and/or nitrofurantoin.

In a specific embodiment, the subject is at risk of, exhibiting symptoms of, or diagnosed with a viral infection such as the influenza A virus including subtype H1N1, influenza B virus, influenza C virus, rotavirus A, rotavirus B, rotavirus C, rotavirus D, rotavirus E, SARS coronavirus, human adenovirus types (HAdV-1 to 55), human papillomavirus (HPV) Types 16, 18, 31, 33, 35, 39, 45, 51, 52, 56, 58, and 59, parvovirus B19, molluscum contagiosum virus, JC virus (JCV), BK virus, Merkel cell polyomavirus, coxsackie A virus, norovirus, Rubella virus,

lymphocytic choriomeningitis virus (LCMV), yellow fever virus, measles virus, mumps virus, respiratory syncytial virus, rinderpest virus, California encephalitis virus, hantavirus, rabies virus, ebola virus, marburg virus, herpes simplex virus-1 (HSV-1), herpes simplex virus-2 (HSV-2), varicella zoster virus (VZV), Epstein-Barr virus (EBV), cytomegalovirus (CMV), herpes lymphotropic virus, roseolovirus, or Kaposi's sarcoma-associated herpesvirus, hepatitis A, hepatitis B, hepatitis C, hepatitis D, hepatitis E, or human immunodeficiency virus (HIV).

In further embodiments, the purified or isolated galectin is administered in combination with one or more of the following antiviral agents: abacavir, acyclovir, acyclovir, adefovir, amantadine, amprenavir, ampligen, arbidol, atazanavir, atripla, boceprevir, cidofovir, combivir, darunavir, delavirdine, didanosine, docosanol, edoxudine, efavirenz, emtricitabine, enfuvirtide, entecavir, famciclovir, fomivirsen, fosamprenavir, foscarnet, fosfonet, ganciclovir, ibacitabine, imunovir, idoxuridine, imiquimod, indinavir, inosine, interferon type III, interferon type II, interferon type I, lamivudine, lopinavir, loviride, maraviroc, moroxydine, methisazone, nelfinavir, nevirapine, nexavir, oseltamivir (Tamiflu), peginterferon alfa-2a, penciclovir, peramivir, pleconaril, podophyllotoxin, raltegravir, ribavirin, rimantadine, ritonavir, pyrimidine, saquinavir, stavudine, tenofovir, tenofovir disoproxil, tipranavir, trifluridine, trizivir, tromantadine, truvada, valaciclovir (Valtrex), valganciclovir, vicriviroc, vidarabine, viramidine, zalcitabine, zanamivir (Relenza), and/or zidovudine (AZT).

In certain embodiments, the disclosure relates to killing PAO5 expressing bacteria by administering pharmaceutical compositions disclosed herein. In certain embodiments, the disclosure relates to kill bacteria expressing sialylated and terminal lactosamine-containing glycans by administering pharmaceutical compositions disclosed herein.

In certain embodiments, the disclosure relates to pharmaceutical compositions comprising peptides with SEQ ID NO:1, SEQ ID NO:2, SEQ ID NO:3, and/or SEQ ID NO:4. In certain embodiments, the pharmaceutical composition comprises a N-terminal fragment of less than 50, 40, 30, 20, or 10 amino acids as provided for in SEQ ID NO:1, SEQ ID NO:2, SEQ ID NO:3, and/or SEQ ID NO:4. In certain embodiments, the pharmaceutical composition comprises a C-terminal fragment of less than 50, 40, 30, 20, or 10 amino acids as provided for in SEQ ID NO:1, SEQ ID NO:2, SEQ ID NO:3, and/or SEQ ID NO:4,

BRIEF DESCRIPTION OF THE FIGURES

Figures 1A-D show glycan microarray data obtained after incubation with 0.2 μM Gal-1 (a), 0.2 μM Gal-3 (b), 0.5 μM Gal-4 (c) and 0.02 μM Gal-8 (d). RFU, relative fluorescence units. Error bars represent means \pm s.e.m.

Figure 1E illustrates the structure of *E. coli* O86 O antigen.

Figures 1F-I show flow cytometric analysis of BGB⁺ *E. coli* counts after incubation of BGB⁺ *E. coli* with Gal-1 (f), Gal-3 (g), Gal-4 (h) or Gal-8 (i), all tested at \sim 0.1 μM with or without inclusion of 20 mM lactose (Lac) where indicated.

Figures 2A-D show data on the quantification of viable bacteria after BGB⁺ *E. coli* were mixed with 5 μM Gal-1, Gal-3, Gal-4 or Gal-8 (a), 5 μM Gal-4 with or without 20 mM lactose (Lac) or 20 mM sucrose (Sucr.) (b), 5 μM Gal-8 with or without 20 mM lactose (Lac) or 20 mM sucrose (Sucr.) (c) or the indicated concentrations of Gal-1, Gal-3, Gal-4 and Gal-8 (d). In each experiment, bacteria were quantified by dilution plating, $n = 3$; one representative experiment in duplicate over two dilutions is shown in a–c. Error bars represent means \pm s.d.

Figure 2 E shows still-frame images from real-time video microscopy showing bacterial mobility at 10-s intervals before and after addition of 5 μM Gal-8, as indicated. Arrows indicate one group of immobilized bacteria. Scale bars, 100 μm .

Figure 2F shows fluorescence microscopy images of BGB⁺ *E. coli* grown to mid-log phase followed by addition of 5 μM Gal-8. Untreated and Gal-8–treated bacteria were stained with propidium iodide (red). Scale bars, 100 μm .

Figure 2G shows transmission electron microscopy images of BGB⁺ *E. coli* after addition of PBS (NT) or 5 μM Gal-8. The bottom images show an enlarged view of a single bacterium. Scale bars, 500 nm.

Figure 2H shows scanning electron microscopy images of BGB⁺ *E. coli* followed by addition of PBS (NT) or Gal-8. Scale bars, 500 nm.

Figure 3A shows data on the quantification of BGB⁺ *E. coli* after addition of 5 μM Gal-8, Gal-8R233H or Gal-8R69H at mid-log phase. Viable bacteria were quantified by dilution plating, $n = 3$ experiments; one representative experiment in duplicate over two dilutions is shown; error bars represent means \pm s.d. of duplicates.

Figure 3B shows flow cytometric analysis of BGB⁺ *E. coli* counts after incubation of BGB⁺ *E. coli* with Gal-8N or Gal-8C at ~0.1 μ M with or without inclusion of 20 mM lactose (Lac) where indicated.

Figure 3C shows data on the quantification of BGB⁺ *E. coli* after addition of 5 μ M Gal-8, Gal-8N or Gal-8C at mid-log phase. Viable bacteria were quantified by dilution plating, n = 3 experiments; one representative experiment in duplicate over two dilutions shown; error bars represent means \pm s.d. of duplicates.

Figure 4D shows flow cytometric analysis of BGB⁺ *E. coli* counts after incubation of BGB⁺ *E. coli* with Gal-4N or Gal-4C at ~0.1 μ M with or without inclusion of 20 mM lactose (Lac) where indicated.

Figure 4E shows data on the quantification of BGB⁺ *E. coli* after addition of 5 μ M Gal-4, Gal-4N or Gal-4C at mid-log phase. Viable bacteria were quantified by dilution plating; n = 3 experiments; one representative experiment in duplicate over two dilutions shown; error bars represent means \pm s.d. of duplicates.

Figure 4A shows flow cytometric analysis of galectin binding after incubation of BGB⁺ *E. coli* and two different BGB⁻ *E. coli* reference strains obtained from a clinical laboratory with ~0.1 μ M Gal-8.

Figures 4B and 4C show data on the quantification of BGB⁺ *E. coli* (b) or BGB⁻ *E. coli* strain 1 (c) after incubation with 5 μ M Gal-1, Gal-3, Gal-4 or Gal-8, as indicated. Viable bacteria were quantified by dilution plating; n = 3 experiments; one representative experiment in duplicate over two dilutions is shown; error bars represent means \pm s.d.

Figure 4D shows flow cytometric analysis of galectin binding after incubation of BGB⁺ *E. coli*, *K. pneumoniae*, *P. aeruginosa* or *S. aureus* with ~0.1 μ M Gal-8.

Figures 4E-G show data on the quantification of *K. pneumoniae* (e), *P. aeruginosa* (f) or *S. aureus* (g) with 5 μ M Gal-1, Gal-3, Gal-4 or Gal-8, as indicated. Viable bacteria were quantified by dilution plating; n = 3 experiments; one representative experiment in duplicate over two dilutions is shown; error bars represent means \pm s.d.

Figures 4H and 4I show data on the quantification of GFP⁺ *P. aeruginosa* alone (h) or GFP⁺ *P. aeruginosa* mixed with BGB⁺ *E. coli* (i) after incubation with or without 5 μ M Gal-8 followed by determination of percentage GFP⁺ *P. aeruginosa* by flow cytometric analysis in a

mixing experiment. Gated counts of GFP⁺ bacteria treated with PBS (blue) or Gal-8 (red) are shown in the upper left corners.

Figure 4J shows data on the quantification of percentage GFP⁺ bacteria by flow cytometric analysis after incubation of Gal-8 with either GFP⁺ *P. aeruginosa* alone (P.a.) or GFP⁺ *P. aeruginosa* mixed with BGB⁺ *E. coli* (P.a. + BGB⁺ E.c.).

Figure 5A is a schematic illustration of O antigen structures on WT BGB⁺ *E. coli* and Δ waaL and Δ wzy mutants of BGB⁺ *E. coli* lacking a complete O antigen.

Figure 5B shows flow cytometric analysis of galectin binding after incubation of BGB⁺, Δ waaL and Δ wzy *E. coli* with \sim 0.1 μ M Gal-8.

Figures 5C and 5D show data after incubation of WT and Δ waaL mutant *E. coli* (c) or WT and Δ wzy mutant *E. coli* (d) with 5 μ M Gal-4 or Gal-8, as indicated. Viable bacteria were quantified by dilution plating; n = 3 experiments; one representative experiment in duplicate over two dilutions shown; error bars represent means \pm s.d.

Figure 6A shows flow cytometric analysis of BGB⁺ *E. coli* counts after incubation of BGB⁺ *E. coli* with \sim 0.1 μ M mouse Gal-4 (mGal-4) with or without lactose.

Figure 6B shows flow cytometric analysis of galectin binding after incubation of BGB⁺ and Δ waaL *E. coli* with \sim 0.1 μ M mGal-4.

Figure 6C shows mGal-4 binding to the Consortium for Functional Glycomics glycan microarray at 20 μ g ml⁻¹ (0.5 μ M).

Figure 6D shows data on the quantification of WT BGB⁺ and Δ waaL mutant *E. coli* after incubation with \sim 5 μ M mGal-4. Viable bacteria were quantified by dilution plating; n = 3 experiments; one representative experiment in duplicate over two dilutions is shown; error bars represent means \pm s.d.

Figure 6E shows data on the quantification of the number of viable bacteria in the intestine of live, antibiotic-treated mice fed PBS, WT BGB⁺ or Δ waaL mutant *E. coli*. The mice were killed 24 h after feeding, and bacteria were quantified by dilution plating. *P = 0.049.

Figure 6F shows data on the growth of WT and Δ waaL mutant BGB⁺ *E. coli* in the presence and absence of thiodigalactoside (TDG). *P = 0.008.

Figure 6G is a schematic illustration of O antigen structures on α -Gal *E. coli*.

Figure 6H shows flow cytometric analysis of α -Gal-expressing bacteria after incubation of α -Gal-expressing bacteria with \sim 0.1 μ M human Gal-4 or Gal-8.

Figure 6I shows data on the percentage of α -Gal-expressing bacteria and BGB- bacteria remaining after incubation with 5 μ M Gal-4 and Gal-8 as compared to PBS-treated control bacteria. Viable bacteria were quantified by dilution plating; $n = 3$ experiments; one representative experiment in duplicate over two dilutions is shown; error bars represent means \pm s.d.

Figures 7A and B show data that suggest Gal-4 and Gal-8 specifically interact with self-like antigens when presented on the MGM. Binding of Gal-4 (A) or Gal-8 (B) on the MGM.

Figure 7C and D show Flow cytometric analysis of *P. alcalifaciens* O5 with Gal-4 (C) or Gal-8 (D) with or with 20 mM TDG or sucrose as indicated.

Figures 7E and F show flow cytometric analysis of *P. alcalifaciens* O21 with Gal-4 (E) or Gal-8 (F) with or with 20 mM TDG or sucrose as indicated.

Figures 7G-J show data where *P. alcalifaciens* O5 (G,H,J) or O21 (I) were grown to mid-log phase as indicated followed by addition of Gal-4 or Gal-8 with or without the addition of 20 mM TDG or sucrose. Viable bacteria were quantified by dilution plating.

Figures 8A-C show analysis of galectin carbohydrate binding specificity following incubation of 0.2 μ M Gal-4 (A) 5 μ M Gal-4 (B), and 5 μ M Gal-8 (C) on the glycan microarray. (RFU, relative fluorescence units.) Error bars represent means \pm s.e.m.

Figure 8D schematically illustrates representation of glycan structures found on the mammalian glycan array paired with similar structures found on various strains of bacteria as indicated.

Figure 8E schematically illustrates representative antigenic structures of related strains that fail to generate self-like antigens.

Figure 8F shows data from flow cytometric analysis of *K. pneumoniae* O1 counts after incubation with Gal-8 with or without inclusion of 20 mM TDG as indicated.

Figures 8G-K show data for *K. pneumoniae* O1 (G,K), *K. pneumoniae* O4 (H), NtHi 2019 (I), or NtHi control (J). Bacteria were grown to mid-log phase as indicated followed by addition of Gal-4 or Gal-8 with or without the addition of 20 mM TDG or sucrose. Viable bacteria were quantified by dilution plating.

Figure 9A schematically illustrates representative glycan structures found on various eukaryotic cells as indicated compared to self-like antigenic structures expressed on pathogens.

Figures 9B and C show data of flow cytometric analysis of WT CHO cell counts (B) or Lec2 cell counts (C) after incubation with Gal-8 with or without inclusion of 20 mM TDG as indicated.

Figures 9D and E show data on the quantification of percent PI positive WT CHO cells (D) and Lec2 cells (E) after incubation with Gal-8. Incubation with Triton X 100 served as the positive control.

Figure 9F shows data on the quantification of hemoglobin release from murine erythrocytes after incubation with Gal-4 or Gal-8.

Figures 9G and H show scanning electron microscopy images of *K. pneumoniae* O1 after incubation with PBS (G) or Gal-8 (H) for 25 minutes.

Figures 9I and J show increased magnification of panels F (I) and G (J) respectively.

DETAILED DISCUSSION

It has been discovered that certain innate immune lectins, e.g., galectin-4 (Gal-4), galectin-7 (Gal-7), galectin-8 (Gal-8) and, galectin Gal-9 (Gal-9) recognize and kill pathogens. The killing activity of Gal-4 and Gal-8 is mediated by their C-terminal domains, occurs rapidly and independently of complement and is accompanied by disruption of membrane integrity. These results demonstrate that innate defense lectins can provide immunity against pathogens that express blood group-like antigens on their surface and suggests that pharmaceutical compositions that contain these domains are useful for the treatment or prevention of certain bacterial infections or infection of other pathogens.

Lectins kill bacteria expressing blood group antigen

The expression of ABO(H) blood group antigens causes deletion of cells that generate self-specific antibodies to these antigens but this deletion limits adaptive immunity toward pathogens bearing cognate blood group antigens. To explore potential defense mechanisms against such pathogens, given these limitations in adaptive immunity, innate proteins that could recognize human blood group antigens were screened. Two innate immune lectins, Gal-4 and Gal-8, which are expressed in the intestinal tract, recognize and kill human blood group antigen-expressing *Escherichia coli* while failing to alter the viability of other *E. coli* strains or certain other Gram-negative or Gram-positive organisms both in vitro and in vivo. The killing activity of

both Gal-4 and Gal-8 is mediated by their C-terminal domains, occurs rapidly and independently of complement and is accompanied by disruption of membrane integrity. The ability of Gal-4 and Gal-8 to specifically kill BGB⁺ E. coli extends previous observations suggesting roles for galectins in innate immunity and may reflect a common but unrealized feature of other innate immune lectins to provide direct protection against pathogens expressing particular self-like antigens, where adaptive immunity cannot.

Similar to many innate immune factors, the galectins represent proteins present in a wide variety of species. As galectins evolved long before the selection of adaptive immunity, it is intriguing to speculate that the types of carbohydrate modifications on some self-antigens, such as blood group antigens, may reflect the binding specificity of preexisting innate immune factors such as the galectins. The generation of ABO(H) antigen diversity in the human population has been proposed to facilitate pathogen evasion during human evolution. See Rowe et al. Proc. Natl. Acad. Sci. USA 104, 17471–17476 (2007). For example, differential expression of blood group ABO(H) antigens in host tissues can differentially affect pathogen adhesion and infection. However, this diversity might have arisen with a considerable fitness cost, as development of these antigens precludes adaptive immune responses against blood group antigen-bearing pathogens. The ability of galectins to recognize blood group antigen-bearing pathogens may have facilitated the selection of ABO(H) expression on human erythrocytes rather than alternative antigens that did not have the same preexisting innate immune protection. In contrast, the ability of Gal-4 and Gal-8 to also kill α -Gal-expressing bacteria shows that galectin-mediated killing is not limited to human blood group antigen-expressing bacteria and suggests that galectins may affect the composition of multiple populations of intestinal bacteria, thereby modulating the intestinal microbiome.

Pharmaceutical Formulations

Pharmaceutical compositions disclosed herein may be in the form of pharmaceutically acceptable salts, as generally described below. Some preferred, but non-limiting examples of suitable pharmaceutically acceptable organic and/or inorganic acids are hydrochloric acid, hydrobromic acid, sulfuric acid, nitric acid, acetic acid, and citric acid, as well as other pharmaceutically acceptable acids known per se (for which reference is made to the references referred to below).

When the compounds of the disclosure contain an acidic group as well as a basic group, the compounds of the disclosure may also form internal salts, and such compounds are within the scope of the disclosure. When a compound contains a hydrogen-donating heteroatom (e.g., NH), salts are contemplated to cover isomers formed by transfer of the hydrogen atom to a basic group or atom within the molecule.

Pharmaceutically acceptable salts of the compounds include the acid addition and base salts thereof. Suitable acid addition salts are formed from acids which form non-toxic salts. Examples include: the acetate, adipate, aspartate, benzoate, besylate, bicarbonate/carbonate, bisulphate/sulphate, borate, camsylate, citrate, cyclamate, edisylate, esylate, formate, fumarate, gluceptate, gluconate, glucuronate, hexafluorophosphate, hibenzate, hydrochloride/chloride, hydrobromide/bromide, hydroiodide/iodide, isethionate, lactate, malate, maleate, malonate, mesylate, methylsulphate, naphthylate, 2-napsylate, nicotinate, nitrate, orotate, oxalate, palmitate, pamoate, phosphate/hydrogen phosphate/dihydrogen phosphate, pyroglutamate, saccharate, stearate, succinate, tannate, tartrate, tosylate, trifluoroacetate and xinofoate salts. Suitable base salts are formed from bases that form non-toxic salts. Examples include the aluminium, arginine, benzathine, calcium, choline, diethylamine, diolamine, glycine, lysine, magnesium, meglumine, olamine, potassium, sodium, tromethamine and zinc salts. Hemisalts of acids and bases may also be formed, for example, hemisulphate and hemicalcium salts. For a review on suitable salts, see Handbook of Pharmaceutical Salts: Properties, Selection, and Use by Stahl and Wermuth (Wiley-VCH, 2002), incorporated herein by reference.

The compounds described herein may be administered in the form of prodrugs. A prodrug can include a covalently bonded carrier that releases the active parent drug when administered to a mammalian subject. Prodrugs can be prepared by modifying functional groups present in the compounds in such a way that the modifications are cleaved, either in routine manipulation or in vivo, to the parent compounds. Prodrugs include, for example, compounds wherein a hydroxyl group is bonded to any group that, when administered to a mammalian subject, cleaves to form a free hydroxyl group. Examples of prodrugs include, but are not limited to, acetate, formate and benzoate derivatives of alcohol functional groups in the compounds. Examples of methods of structuring a compound as prodrugs can be found in the book of Testa and Mayer, Hydrolysis in Drug and Prodrug Metabolism, Wiley (2006), which is incorporated herein by reference. Typical prodrugs form the active metabolite by transformation

of the prodrug by hydrolytic enzymes, the hydrolysis of amide, lactams, peptides, carboxylic acid esters, epoxides or the cleavage of esters or inorganic acids.

Pharmaceutical compositions typically comprise an effective amount of a compound and a suitable pharmaceutical acceptable carrier. The preparations may be prepared in a manner known per se, which usually involves mixing the at least one compound according to the disclosure with the one or more pharmaceutically acceptable carriers, and, if desired, in combination with other pharmaceutical active compounds, when necessary under aseptic conditions. Reference is made to U.S. Pat. No. 6,372,778, U.S. Pat. No. 6,369,086, U.S. Pat. No. 6,369,087, and U.S. Pat. No. 6,372,733 and the further references mentioned above, as well as to the standard handbooks, such as the latest edition of Remington's Pharmaceutical Sciences. It is well known that ester prodrugs are readily degraded in the body to release the corresponding alcohol. See e.g., Imai, Drug Metab Pharmacokinet. (2006) 21(3):173-85, entitled "Human carboxylesterase isozymes: catalytic properties and rational drug design."

Generally, for pharmaceutical use, the compounds may be formulated as a pharmaceutical preparation comprising at least one compound and at least one pharmaceutically acceptable carrier, diluent or excipient and/or adjuvant, and optionally one or more further pharmaceutically active compounds.

The pharmaceutical preparations of the disclosure are preferably in a unit dosage form, and may be suitably packaged, for example in a box, blister, vial, bottle, sachet, ampoule or in any other suitable single-dose or multi-dose holder or container (which may be properly labeled); optionally with one or more leaflets containing product information and/or instructions for use. Generally, such unit dosages will contain between 1 and 1000 mg, and usually between 5 and 500 mg, of the at least one compound of the disclosure, e.g., about 10, 25, 50, 100, 200, 300 or 400 mg per unit dosage.

The compounds can be administered by a variety of routes including the oral, ocular, rectal, transdermal, subcutaneous, intravenous, intramuscular or intranasal routes, depending mainly on the specific preparation used. The compound will generally be administered in an "effective amount", by which it is meant any amount of a compound that, upon suitable administration, is sufficient to achieve the desired therapeutic or prophylactic effect in the subject to which it is administered. Usually, depending on the condition to be prevented or treated and the route of administration, such an effective amount will usually be between 0.01 to

1000 mg per kilogram body weight of the patient per day, more often between 0.1 and 500 mg, such as between 1 and 250 mg, for example about 5, 10, 20, 50, 100, 150, 200 or 250 mg, per kilogram body weight of the patient per day, which may be administered as a single daily dose, divided over one or more daily doses. The amount(s) to be administered, the route of administration and the further treatment regimen may be determined by the treating clinician, depending on factors such as the age, gender and general condition of the patient and the nature and severity of the disease/symptoms to be treated. Reference is made to U.S. Pat. No. 6,372,778, U.S. Pat. No. 6,369,086, U.S. Pat. No. 6,369,087, and U.S. Pat. No. 6,372,733 and the further references mentioned above, as well as to the standard handbooks, such as the latest edition of Remington's Pharmaceutical Sciences.

Formulations containing one or more of the compounds described herein may be prepared using a pharmaceutically acceptable carrier composed of materials that are considered safe and effective and may be administered to an individual without causing undesirable biological side effects or unwanted interactions. The carrier is all components present in the pharmaceutical formulation other than the active ingredient or ingredients. As generally used herein, "carrier" includes, but is not limited to, diluents, binders, lubricants, disintegrators, fillers, pH modifying agents, preservatives, antioxidants, solubility enhancers, and coating compositions.

Carrier also includes all components of the coating composition which may include plasticizers, pigments, colorants, stabilizing agents, and glidants. Delayed release, extended release, and/or pulsatile release dosage formulations may be prepared as described in standard references such as "Pharmaceutical dosage form tablets", eds. Liberman et. al. (New York, Marcel Dekker, Inc., 1989), "Remington – The science and practice of pharmacy", 20th ed., Lippincott Williams & Wilkins, Baltimore, MD, 2000, and "Pharmaceutical dosage forms and drug delivery systems", 6th Edition, Ansel et al., (Media, PA: Williams and Wilkins, 1995). These references provide information on carriers, materials, equipment and process for preparing tablets and capsules and delayed release dosage forms of tablets, capsules, and granules.

Examples of suitable coating materials include, but are not limited to, cellulose polymers such as cellulose acetate phthalate, hydroxypropyl cellulose, hydroxypropyl methylcellulose, hydroxypropyl methylcellulose phthalate and hydroxypropyl methylcellulose acetate succinate; polyvinyl acetate phthalate, acrylic acid polymers and copolymers, and methacrylic resins that

are commercially available under the trade name EUDRAGIT® (Roth Pharma, Westerstadt, Germany), zein, shellac, and polysaccharides.

Additionally, the coating material may contain conventional carriers such as plasticizers, pigments, colorants, glidants, stabilization agents, pore formers, and surfactants.

Optional pharmaceutically acceptable excipients present in the drug-containing tablets, beads, granules or particles include, but are not limited to, diluents, binders, lubricants, disintegrants, colorants, stabilizers, and surfactants. Diluents, also referred to as "fillers," are typically necessary to increase the bulk of a solid dosage form so that a practical size is provided for compression of tablets or formation of beads and granules. Suitable diluents include, but are not limited to, dicalcium phosphate dihydrate, calcium sulfate, lactose, sucrose, mannitol, sorbitol, cellulose, microcrystalline cellulose, kaolin, sodium chloride, dry starch, hydrolyzed starches, pregelatinized starch, silicone dioxide, titanium oxide, magnesium aluminum silicate, and powdered sugar.

Binders are used to impart cohesive qualities to a solid dosage formulation, and thus ensure that a tablet or bead or granule remains intact after the formation of the dosage forms. Suitable binder materials include, but are not limited to, starch, pregelatinized starch, gelatin, sugars (including sucrose, glucose, dextrose, lactose and sorbitol), polyethylene glycol, waxes, natural and synthetic gums such as acacia, tragacanth, sodium alginate, cellulose, including hydroxypropylmethylcellulose, hydroxypropylcellulose, ethylcellulose, and veegum, and synthetic polymers such as acrylic acid and methacrylic acid copolymers, methacrylic acid copolymers, methyl methacrylate copolymers, aminoalkyl methacrylate copolymers, polyacrylic acid/polymethacrylic acid, and polyvinylpyrrolidone.

Lubricants are used to facilitate tablet manufacture. Examples of suitable lubricants include, but are not limited to, magnesium stearate, calcium stearate, stearic acid, glycerol behenate, polyethylene glycol, talc, and mineral oil.

Disintegrants are used to facilitate dosage form disintegration or "breakup" after administration, and generally include, but are not limited to, starch, sodium starch glycolate, sodium carboxymethyl starch, sodium carboxymethylcellulose, hydroxypropyl cellulose, pregelatinized starch, clays, cellulose, alginine, gums or cross linked polymers, such as cross-linked PVP (Polyplasdone XL from GAF Chemical Corp).

Stabilizers are used to inhibit or retard drug decomposition reactions that include, by way of example, oxidative reactions.

Surfactants may be anionic, cationic, amphoteric or nonionic surface active agents. Suitable anionic surfactants include, but are not limited to, those containing carboxylate, sulfonate and sulfate ions. Examples of anionic surfactants include sodium, potassium, ammonium of long chain alkyl sulfonates and alkyl aryl sulfonates such as sodium dodecylbenzene sulfonate; dialkyl sodium sulfosuccinates, such as sodium dodecylbenzene sulfonate; dialkyl sodium sulfosuccinates, such as sodium bis-(2-ethylthioxy)-sulfosuccinate; and alkyl sulfates such as sodium lauryl sulfate. Cationic surfactants include, but are not limited to, quaternary ammonium compounds such as benzalkonium chloride, benzethonium chloride, cetrimonium bromide, stearyl dimethylbenzyl ammonium chloride, polyoxyethylene, and coconut amine. Examples of nonionic surfactants include ethylene glycol monostearate, propylene glycol myristate, glyceryl monostearate, glyceryl stearate, polyglyceryl-4-oleate, sorbitan acylate, sucrose acylate, PEG-150 laurate, PEG-400 monolaurate, polyoxyethylene monolaurate, polysorbates, polyoxyethylene octylphenylether, PEG-1000 cetyl ether, polyoxyethylene tridecyl ether, polypropylene glycol butyl ether, Poloxamer® 401, stearyl monoisopropanolamide, and polyoxyethylene hydrogenated tallow amide. Examples of amphoteric surfactants include sodium N-dodecyl-.beta.-alanine, sodium N-lauryl-.beta.-iminodipropionate, myristoamphoacetate, lauryl betaine, and lauryl sulfobetaine.

If desired, the tablets, beads, granules, or particles may also contain minor amount of nontoxic auxiliary substances such as wetting or emulsifying agents, dyes, pH buffering agents, or preservatives.

The compositions described herein can be formulation for modified or controlled release. Examples of controlled release dosage forms include extended release dosage forms, delayed release dosage forms, pulsatile release dosage forms, and combinations thereof.

The extended release formulations are generally prepared as diffusion or osmotic systems, for example, as described in "Remington – The science and practice of pharmacy" (20th ed., Lippincott Williams & Wilkins, Baltimore, MD, 2000). A diffusion system typically consists of two types of devices, a reservoir and a matrix, and is well known and described in the art. The matrix devices are generally prepared by compressing the drug with a slowly dissolving polymer carrier into a tablet form. The three major types of materials used in the preparation of

matrix devices are insoluble plastics, hydrophilic polymers, and fatty compounds. Plastic matrices include, but are not limited to, methyl acrylate-methyl methacrylate, polyvinyl chloride, and polyethylene. Hydrophilic polymers include, but are not limited to, cellulosic polymers such as methyl and ethyl cellulose, hydroxyalkylcelluloses such as hydroxypropyl-cellulose, hydroxypropylmethylcellulose, sodium carboxymethylcellulose, and Carbopol® 934, polyethylene oxides and mixtures thereof. Fatty compounds include, but are not limited to, various waxes such as carnauba wax and glyceryl tristearate and wax-type substances including hydrogenated castor oil or hydrogenated vegetable oil, or mixtures thereof.

In certain preferred embodiments, the plastic material is a pharmaceutically acceptable acrylic polymer, including but not limited to, acrylic acid and methacrylic acid copolymers, methyl methacrylate, methyl methacrylate copolymers, ethoxyethyl methacrylates, cyanoethyl methacrylate, aminoalkyl methacrylate copolymer, poly(acrylic acid), poly(methacrylic acid), methacrylic acid alkylamine copolymer poly(methyl methacrylate), poly(methacrylic acid)(anhydride), polymethacrylate, polyacrylamide, poly(methacrylic acid anhydride), and glycidyl methacrylate copolymers.

In certain preferred embodiments, the acrylic polymer is comprised of one or more ammonio methacrylate copolymers. Ammonio methacrylate copolymers are well known in the art, and are described in NF XVII as fully polymerized copolymers of acrylic and methacrylic acid esters with a low content of quaternary ammonium groups.

In one preferred embodiment, the acrylic polymer is an acrylic resin lacquer such as that which is commercially available from Rohm Pharma sold as Eudragit®. In further preferred embodiments, the acrylic polymer comprises a mixture of two acrylic resin lacquers commercially available from Rohm Pharma sold as Eudragit® RL30D and Eudragit® RS30D, respectively. Eudragit® RL30D and Eudragit® RS30D are copolymers of acrylic and methacrylic esters with a low content of quaternary ammonium groups, the molar ratio of ammonium groups to the remaining neutral (meth)acrylic esters being 1:20 in Eudragit® RL30D and 1:40 in Eudragit® RS30D. The mean molecular weight is about 150,000. Eudragit® S-100 and Eudragit® L-100 are also preferred. The code designations RL (high permeability) and RS (low permeability) refer to the permeability properties of these agents. Eudragit® RL/RS mixtures are insoluble in water and in digestive fluids. However, multiparticulate systems

formed to include the same are swellable and permeable in aqueous solutions and digestive fluids.

The polymers described above, such as Eudragit® RL/RS, may be mixed together in any desired ratio in order to ultimately obtain a sustained-release formulation having a desirable dissolution profile. Desirable sustained-release multiparticulate systems may be obtained, for instance, from 100% Eudragit® RL, 50% Eudragit® RL and 50% Eudragit® RS, and 10% Eudragit® RL and 90% Eudragit® RS. One skilled in the art will recognize that other acrylic polymers may also be used, such as, for example, Eudragit® L.

Alternatively, extended release formulations can be prepared using osmotic systems or by applying a semi-permeable coating to the dosage form. In the latter case, the desired drug release profile can be achieved by combining low permeable and high permeable coating materials in suitable proportion.

The devices with different drug release mechanisms described above can be combined in a final dosage form comprising single or multiple units. Examples of multiple units include, but are not limited to, multilayer tablets and capsules containing tablets, beads, or granules. An immediate release portion can be added to the extended release system by means of either applying an immediate release layer on top of the extended release core using a coating or compression process or in a multiple unit system such as a capsule containing extended and immediate release beads.

Extended release tablets containing hydrophilic polymers are prepared by techniques commonly known in the art such as direct compression, wet granulation, or dry granulation. Their formulations usually incorporate polymers, diluents, binders, and lubricants as well as the active pharmaceutical ingredient. The usual diluents include inert powdered substances such as starches, powdered cellulose, especially crystalline and microcrystalline cellulose, sugars such as fructose, mannitol and sucrose, grain flours, and similar edible powders. Typical diluents include, for example, various types of starch, lactose, mannitol, kaolin, calcium phosphate or sulfate, inorganic salts such as sodium chloride and powdered sugar. Powdered cellulose derivatives are also useful. Typical tablet binders include substances such as starch, gelatin and sugars such as lactose, fructose, and glucose. Natural and synthetic gums, including acacia, alginates, methylcellulose, and polyvinylpyrrolidone can also be used. Polyethylene glycol, hydrophilic polymers, ethylcellulose, and waxes can also serve as binders. A lubricant is

necessary in a tablet formulation to prevent the tablet and punches from sticking in the die. The lubricant is chosen from such slippery solids as talc, magnesium and calcium stearate, stearic acid, and hydrogenated vegetable oils.

Extended release tablets containing wax materials are generally prepared using methods known in the art such as a direct blend method, a congealing method, and an aqueous dispersion method. In the congealing method, the drug is mixed with a wax material and either spray-congealed or congealed and screened and processed.

Delayed release formulations are created by coating a solid dosage form with a polymer film, which is insoluble in the acidic environment of the stomach, and soluble in the neutral environment of the small intestine.

The delayed release dosage units can be prepared, for example, by coating a drug or a drug-containing composition with a selected coating material. The drug-containing composition may be, e.g., a tablet for incorporation into a capsule, a tablet for use as an inner core in a "coated core" dosage form, or a plurality of drug-containing beads, particles or granules, for incorporation into either a tablet or capsule. Preferred coating materials include bioerodible, gradually hydrolyzable, gradually water-soluble, and/or enzymatically degradable polymers, and may be conventional "enteric" polymers. Enteric polymers, as will be appreciated by those skilled in the art, become soluble in the higher pH environment of the lower gastrointestinal tract or slowly erode as the dosage form passes through the gastrointestinal tract, while enzymatically degradable polymers are degraded by bacterial enzymes present in the lower gastrointestinal tract, particularly in the colon. Suitable coating materials for effecting delayed release include, but are not limited to, cellulosic polymers such as hydroxypropyl cellulose, hydroxyethyl cellulose, hydroxymethyl cellulose, hydroxypropyl methyl cellulose, hydroxypropyl methyl cellulose acetate succinate, hydroxypropylmethyl cellulose phthalate, methylcellulose, ethyl cellulose, cellulose acetate, cellulose acetate phthalate, cellulose acetate trimellitate and carboxymethylcellulose sodium; acrylic acid polymers and copolymers, preferably formed from acrylic acid, methacrylic acid, methyl acrylate, ethyl acrylate, methyl methacrylate and/or ethyl methacrylate, and other methacrylic resins that are commercially available under the tradename Eudragit® (Rohm Pharma; Westerstadt, Germany), including Eudragit® L30D-55 and L100-55 (soluble at pH 5.5 and above), Eudragit® L-100 (soluble at pH 6.0 and above), Eudragit® S (soluble at pH 7.0 and above, as a result of a higher degree of esterification), and Eudragits® NE,

RL and RS (water-insoluble polymers having different degrees of permeability and expandability); vinyl polymers and copolymers such as polyvinyl pyrrolidone, vinyl acetate, vinylacetate phthalate, vinylacetate crotonic acid copolymer, and ethylene-vinyl acetate copolymer; enzymatically degradable polymers such as azo polymers, pectin, chitosan, amylose and guar gum; zein; and shellac. Combinations of different coating materials may also be used. Multi-layer coatings using different polymers may also be applied.

The preferred coating weights for particular coating materials may be readily determined by those skilled in the art by evaluating individual release profiles for tablets, beads and granules prepared with different quantities of various coating materials. It is the combination of materials, method and form of application that produce the desired release characteristics, which one can determine only from the clinical studies.

The coating composition may include conventional additives, such as plasticizers, pigments, colorants, stabilizing agents, glidants, etc. A plasticizer is normally present to reduce the fragility of the coating, and will generally represent about 10 wt. % to 50 wt. % relative to the dry weight of the polymer. Examples of typical plasticizers include polyethylene glycol, propylene glycol, triacetin, dimethyl phthalate, diethyl phthalate, dibutyl phthalate, dibutyl sebacate, triethyl citrate, tributyl citrate, triethyl acetyl citrate, castor oil, and acetylated monoglycerides. A stabilizing agent is preferably used to stabilize particles in the dispersion. Typical stabilizing agents are nonionic emulsifiers such as sorbitan esters, polysorbates, and polyvinylpyrrolidone. Glidants are recommended to reduce sticking effects during film formation and drying, and will generally represent approximately 25 wt. % to 100 wt. % of the polymer weight in the coating solution. One effective glidant is talc. Other glidants, such as magnesium stearate and glycerol monostearates, may also be used. Pigments, such as titanium dioxide, may also be used. Small quantities of an anti-foaming agent, such as a silicone (e.g., simethicone), may also be added to the coating composition.

Alternatively, each dosage unit in the capsule may comprise a plurality of drug-containing beads, granules or particles. As is known in the art, drug-containing "beads" refer to beads made with drug and one or more excipients or polymers. Drug-containing beads can be produced by applying drug to an inert support, e.g., inert sugar beads coated with drug or by creating a "core" comprising both drug and one or more excipients. As is also known, drug-containing "granules" and "particles" comprise drug particles that may or may not include one or

more additional excipients or polymers. In contrast to drug-containing beads, granules and particles do not contain an inert support. Granules generally comprise drug particles and require further processing. Generally, particles are smaller than granules, and are not further processed. Although beads, granules and particles may be formulated to provide immediate release, beads and granules are generally employed to provide delayed release.

Terms

A “lectin” refers to a carbohydrate binding protein, e.g., but not limited to, mannose, galactose, glucosamine, and fructose binding lectins. The galectins are lectins that are beta-galactoside-binding proteins, such as lactose, implicated in modulating cell-cell and cell-matrix interactions. The expression of galectins is thought to be restricted to small intestine, colon, and rectum.

Galectin-4 (Gal-4) has SEQ ID NO 1:

MAYVPAPGYQPTYNPTLPYYQPIPGGLNVGMSVYIQGVASEHMKRFFVNFVVGQDPGS
 DVAFHFNPRFDGWDKVVFNLTQGGKKGSEERKRSMPPFKKGAAFELVFIVLAEHYKVV
 VNGNPFYEYGHRLPLQMVTHLQVDGDLQLQSINFIGGQPLRPQGPPMPPYPGPGHCH
 QQLNSLPTMEGPPTFNPPVPYFGRLQGGLTARRTIIKGYVPPTGKSFAINFKVGSSGDIAL
 HINPRMNGTIVRNSLLNGSWGSEEEKKITHNPFPGQFFDLSIRCGLDRFKVYANGQHL
 FDFAHRLSAFQRVDTLEIQGDVTL SYVQi

Galectin-7 (Gal-7) has SEQ ID NO 2:

MSNVPHKSSLPEGIRPGTVLRIRGLVPPNASRFHVNLLCGEEQGSDAALHFNPRLDTSEV
 VFNSKEQGSWGREERGPVPPFQRGQPFEVLIASDDGFKAVVGDAQYHHFRHRLPLARV
 RLVEVGGDVQLDSVRIF

Galectin-8 (Gal-8) has SEQ ID NO 3:

MMLSLNQLQNIINPVPFVGTIPDQLDPGTLIVIRGHVPSDADRFQVDLQNGSSMKPRA
 DVAFHFNPRFKRAGCIVCNTLINEKWGREEITYDTPFKREKSFEIVIMVLKDKFQVAVNG
 KHTLLYGHRIPEKIDTLGIYGKVNHSIGFSFSSDLQSTQASSLELTEISRENVPKSGTPQL
 PSNRGGDISKIAPRTVYTKSKDSTVNHTLTCTKIPPMNYVSKRLPFAARLNTMPMGPGRTV
 VVKGEVNANAKSFNVDLLAGKSKDIALHLNPNLNIKAFVRNSFLQESWGEEERNITSFPF
 SPGMYFEMIIYCDVREFKVA VNGVHSLEYKHRFKELSSIDTLEINGDIHLLEVR SW

Galectin-9 (Gal-9) has SEQ ID NO 4

MAFSGSQAPYLSPA VPFSGTIQGGLQDGLQITVNGTVLSSSGTRFAVNFQTGFSGNDIAF
 HFNPRFEDGGYVVCNTRQNGSWGPEERKTHMPFQKGMFDLCFLVQSSDFKVMVNGIL
 FVQYFHRVPFHRVDTISVNGSVQLSYISFQPPGVWPANPAPITQTVIHTVQSAPGQMFSTP
 AIPPMYHPAYPMPFITLGGLYPSKSILLSGTVLPSAQRFHINLCSGNHIAFHNLNPRFD
 ENAVVRNTQIDNSWGSEERSLPRKMPFVRGQSFSVWILCEAHCLKVAVDGQHLEFYH
 RLRNLPTINRLEVGGDIQLTHVQT

The terms “Gal-4,” “Gal-7,” “Gal-8,” “Gal-9” and N- and C-terminal binding domains are not necessarily intended to be limited to the specific sequences provided above. Minor changes and derivatization may result in a molecule that continues to bind beta-galactoside, and it is intended that the term include such isoforms, homologs, analogs, variants, fragments or derivatives thereof. For example, the Gal-8 gene is relatively conserved in chimpanzee, dog, cow, mouse, rat, chicken, and zebrafish, and the term is intended to include these homologs, isoforms, analogs, variants, fragments or derivatives thereof.

Analogous may differ from naturally occurring proteins or peptides by conservative amino acid sequence differences or by modifications which do not affect sequence, or by both. For example, conservative amino acid changes may be made, which although they alter the primary sequence of the protein or peptide, do not normally alter its function. Conservative amino acid substitutions typically include substitutions within the following groups: glycine for alanine; valine for isoleucine or for leucine; aspartic acid for glutamic acid; asparagine for glutamine; serine for threonine; lysine for arginine; phenylalanine for tyrosine; and vice versa.

Modifications (which do not normally alter primary sequence) include *in vivo* or *in vitro* chemical derivatization of polypeptides, *e.g.*, acetylation, or carboxylation. Also included are polypeptides which have been modified using ordinary molecular biological techniques so as to improve their resistance to proteolytic degradation or to optimize solubility properties or to render them more suitable as a therapeutic agent. Analogous of such polypeptides include those containing residues other than naturally occurring L-amino acids, *e.g.*, D-amino acids or non-naturally occurring synthetic amino acids. The peptides of the disclosure are not limited to products of any of the specific exemplary processes listed herein.

In certain embodiments, the present disclosure should also be construed to encompass “mutants,” “derivatives,” and “variants” of the peptides disclosed herein (or of the DNA encoding the same) which are altered in one or more amino acids (or, when referring to the

nucleotide sequence encoding the same, are altered in one or more base pairs) such that the resulting peptide (or DNA) is not identical to the sequences recited herein,

As used herein, the term "fragment," as applied to a protein or peptide, refers to a subsequence of a larger protein or peptide. A "fragment" of a protein or peptide can be at least about 20 amino acids in length; for example at least about 50 amino acids in length; at least about 100 amino acids in length, at least about 200 amino acids in length, at least about 300 amino acids in length, and at least about 400 amino acids in length (and any integer value in between).

"Variant" as the term is used herein, is a nucleic acid sequence or a peptide sequence that differs in sequence from a reference nucleic acid sequence or peptide sequence respectively, but retains essential properties of the reference molecule. Changes in the sequence of a nucleic acid variant may not alter the amino acid sequence of a peptide encoded by the reference nucleic acid, or may result in amino acid substitutions, additions, deletions, fusions and truncations. Changes in the sequence of peptide variants are typically limited or conservative, so that the sequences of the reference peptide and the variant are closely similar overall and, in many regions, identical. A variant and reference peptide can differ in amino acid sequence by one or more substitutions, additions, deletions in any combination. A variant of a nucleic acid or peptide can be a naturally occurring such as an allelic variant, or can be a variant that is not known to occur naturally. Non-naturally occurring variants of nucleic acids and peptides may be made by mutagenesis techniques or by direct synthesis.

"Isolated" means altered or removed from the natural state. For example, a nucleic acid or a peptide naturally present in a living animal is not "isolated," but the same nucleic acid or peptide partially or completely separated from the coexisting materials of its natural state is "isolated." An isolated nucleic acid or protein can exist in substantially purified form, or can exist in a non-native environment such as, for example, a host cell.

As used herein, "salts" refer to derivatives of the disclosed compounds where the parent compound is modified making acid or base salts thereof. Examples of salts include, but are not limited to, mineral or organic acid salts of basic residues, such as amines, alkylamines, or dialkylamines; alkali or organic salts of acidic residues such as carboxylic acids; and the like. In the preferred embodiments, the salts are conventional nontoxic pharmaceutically acceptable salts including the quaternary ammonium salts of the parent compound formed, and non-toxic

inorganic or organic acids. Preferred salts include those derived from inorganic acids, such as hydrochloric, hydrobromic, sulfuric, sulfamic, phosphoric, nitric, and the like; and the salts prepared from organic acids, such as acetic, propionic, succinic, glycolic, stearic, lactic, malic, tartaric, citric, ascorbic, pantoic, maleic, hydroxymaleic, phenylacetic, glutamic, benzoic, salicylic, sulfanilic, 2-acetoxybenzoic, fumaric, toluenesulfonic, methanesulfonic, ethane disulfonic, oxalic, isethionic, and the like.

"Subject" refers any animal, preferably a human patient, livestock, or domestic pet.

As used herein, the terms "prevent" and "preventing" include the prevention of the recurrence, spread or onset. It is not intended that the present disclosure be limited to complete prevention. In some embodiments, the onset is delayed, or the severity of the disease is reduced.

As used herein, the terms "treat" and "treating" are not limited to the case where the subject (e.g. patient) is cured and the disease is eradicated. Rather, embodiments of the present disclosure also contemplate treatment that merely reduces symptoms, and/or delays disease progression.

EXPERIMENTAL

Example 1: Galectins recognize blood group–positive bacteria

Publicly available data from the screening of nearly 100 different lectins from the Consortium for Functional Glycomics, many of which are mammalian lectins with documented immunological activity, including members of the galectin family was analyzed. Members of the galectin family had some of the most specific interactions observed among the lectins tested after screening of over 300 structurally diverse glycans. Human Gal-3, Gal-4 and Gal-8, which recognize multiple glycan structures at relatively high concentrations showed specificity for human blood group A and B antigens at submicromolar concentrations and did not bind blood group O(H) at these concentrations, whereas human Gal-1, a related galectin family member, did not recognize blood group antigens (Fig. 1a–d). This specificity was not as striking in previous studies concerning members of this protein family, where binding at high protein concentrations was tested. The lectins were found to recognized multiple carbohydrate ligands along with blood group antigens. Stowell et al., *J. Biol. Chem.* 283, 10109–10123 (2008). Stowell et al., *J. Biol. Chem.* 283, 20547–20559 (2008).

Bacteria generate a wide variety of glycan-based antigenic structures, many of which can possess blood group antigen activity. *E. coli* O86, cross-reacts with antibodies specific for human blood group B and induces high titers of blood group B-specific antibodies in previously unexposed individuals. Notably, whereas individuals of blood group A or O produce antibodies that kill *E. coli* O86, individuals with blood group B do not generate antibodies capable of altering *E. coli* O86 viability, providing a specific example of the immunological limitation in adaptive immunity toward a blood group antigen-bearing pathogen. Although *E. coli* O86 generates an identical blood group B epitope (Fig. 1e) to that of humans, the context of this epitope may differ from the common human presentations found on the glycan microarray. Therefore, whether Gal-3, Gal-4 and Gal-8 recognize *E. coli* O86 was examined. Consistent with their ability to specifically recognize blood group A and B antigens on the glycan microarray, human Gal-3, Gal-4 and Gal-8, but not Gal-1, bound *E. coli* O86, hereafter referred to as blood group B-positive *E. coli* (BGB⁺ *E. coli*) (Fig. 1f-i). Binding of all galectins to bacteria was inhibited by lactose, an inhibitor of galectin-carbohydrate interactions (Fig. 1f-i), indicating that galectin bound glycan determinants on the surface of BGB⁺ *E. coli*.

Example 2: Gal-4 and Gal-8 kill blood group-positive bacteria

Studies showed high galectin expression in the intestinal mucosa, where the galectins may serve as pathogen recognition proteins, suggesting that Gal-3, Gal-4 and Gal-8 may facilitate innate immunity toward BGB⁺ pathogens. Although studies disclose that several innate immune lectins can directly affect pathogen viability, there is no direct evidence as to whether galectins can alter prokaryote viability. See Cash et al., *Science* 313, 1126–1130 (2006), Vasta, *Nat. Rev. Microbiol.* 7, 424–438 (2009), Kohatsu et al. *J. Immunol.* 177, 4718–4726 (2006), and Thiel, S. et al. *Nature* 386, 506–510 (1997).

Whether galectins might confer intrinsic immunity by directly killing BGB⁺ *E. coli* was examined. Incubation with both Gal-4 and Gal-8 caused direct killing of BGB⁺ *E. coli*, whereas Gal-3, which also binds BGB⁺ *E. coli*, did not affect viability, and Gal-1, which does not bind BGB⁺ *E. coli*, had no effect (Fig. 2a). Lactose completely inhibited both Gal-4- and Gal-8-induced death, whereas sucrose, a disaccharide unable to inhibit galectin-carbohydrate interactions, failed to alter killing of BGB⁺ *E. coli* (Fig. 2b,c). Gal-4 and Gal-8 showed similarly potent concentration-dependent killing of BGB⁺ *E. coli*, with a half-maximal lethal dose of ~0.1

μM (Fig. 2d), a concentration similar to that observed *in vivo* and used to evaluate glycan binding specificity on the glycan microarray. In addition, the effects of Gal-8 treatment seemed to be rapid, as treated BGB⁺ *E. coli* lost all motility compared to untreated BGB⁺ *E. coli* shortly after the addition of Gal-8 (Fig. 2e). BGB⁺ *E. coli* positively stained for propidium iodide after a 30 min incubation with Gal-8 (Fig. 2f) and showed considerable disruption of membrane morphology (Fig. 2g,h). These results show that Gal-8 kills BGB⁺ *E. coli* by directly altering membrane integrity. Comparable alterations were observed after incubation with Gal-4 (data not shown). Taken together, these results show that both human Gal-4 and Gal-8 directly kill BGB⁺ *E. coli* through recognition of bacterial surface carbohydrates via a mechanism that drastically alters membrane integrity and bacterial motility. Killing of BGB⁺ *E. coli* by human Gal-4 and Gal-8 did not require complement (Fig. 2), demonstrating that these lectins fundamentally differ from other innate immune lectins, such as mannan-binding proteins, which do not directly alter viability but activate complement after pathogen recognition.

Unlike Gal-1 and Gal-3, which contain a single carbohydrate recognition domain (CRD), Gal-4 and Gal-8 have two distinct CRDs, suggesting that these galectins may use one domain for target recognition and the other domain for killing the target once bound, similarly to many prokaryotic AB toxins. To distinguish these possibilities, we mutated each CRD of Gal-8, in the context of the whole protein, to determine which domain recognizes BGB⁺ *E. coli*. Inactivation of the C-terminal CRD (R233H) (Gal-8R233H) eliminated recognition of blood group antigens on both the glycan microarray and BGB⁺ *E. coli*, whereas the analogous mutation in the N-terminal CRD (R69H) (Gal-8R69H) did not alter blood group antigen recognition in either context. Of note, Gal-8R69H, but not Gal-8R233H, killed BGB⁺ *E. coli* (Fig. 3a), which indicates that Gal-8-mediated killing requires carbohydrate recognition only by the blood group-binding C-terminal domain of Gal-8. To determine whether the N-terminal domain is required for Gal-8 killing independently of glycan recognition, the individual domains of Gal-8 were expressed. Whereas the N-terminal domain (Gal-8N) failed to bind blood group antigens on either the glycan microarray or BGB⁺ *E. coli* (Fig. 3b and data not shown), the C-terminal domain of Gal-8 (Gal-8C) independently recognized blood group antigens and killed BGB⁺ *E. coli* (Fig. 3b,c). These results show that recognition and killing of BGB⁺ *E. coli* by Gal-8 resides entirely within its blood group-binding domain. By contrast, both domains of Gal-4 showed specific recognition of BGB⁺ *E. coli* (Fig. 3d). Thus, we asked whether Gal-4N and Gal-4C

might independently kill BGB⁺ *E. coli*. However, similar to Gal-3, Gal-4N showed substantial recognition of BGB⁺ *E. coli* yet failed to alter BGB⁺ *E. coli* viability (Fig. 2a and Fig. 3e). By contrast, Gal-4C had substantial killing activity toward BGB⁺ *E. coli* (Fig. 3e). Notably, the Gal-4C and Gal-8C domains show phylogenetic similarities not shared by Gal-3 and the Gal-4N domain, which suggests a conserved mechanism shared between these two protein domains.

Example 3: Galectin killing requires blood group antigen recognition

The ability of the blood group-binding domain of Gal-4 and Gal-8 to independently kill BGB⁺ *E. coli* (Fig. 3a,c,e) suggested that Gal-4 and Gal-8 might specifically kill BGB⁺ *E. coli*. To test this, whether Gal-4 and Gal-8 recognize strains of *E. coli* that fail to express the blood group B-related antigen was examined. Although both Gal-4 and Gal-8 recognize BGB⁺ *E. coli*, they did not substantially bind or affect the viability of BGB⁻ *E. coli* (Fig. 4a-c and data not shown). In addition, Gal-4 and Gal-8 did not recognize or kill the Gram-negative, BGB⁻ species *Klebsiella pneumoniae* and *Pseudomonas aeruginosa*, and they neither bound nor altered the viability of Gram-positive *Staphylococcus aureus* (Fig. 4d-g and data not shown). We next asked whether Gal-8 specifically kills BGB⁺ *E. coli* in a mixed population of BGB⁺ and BGB⁻ bacteria. We incubated GFP⁺ BGB⁻ *P. aeruginosa* with Gal-8 to determine whether Gal-8 altered GFP expression or viability. Gal-8 failed to alter GFP expression (Fig. 4h) or viability, allowing us to discriminate between GFP⁺ *P. aeruginosa* and BGB⁺ *E. coli* within a mixed population. To examine whether Gal-8 specifically kills BGB⁺ *E. coli*, various ratios of BGB⁺ *E. coli* to GFP⁺ *P. aeruginosa* were incubated with or without Gal-8. Even at a 4:1 ratio of BGB⁺ *E. coli*:GFP⁺ *P. aeruginosa*, Gal-8 selectively eliminated the GFP⁻ BGB⁺ *E. coli* (Fig. 4i,j). Furthermore, defined mutations that prevent synthesis of the blood group antigen formation on BGB⁺ *E. coli* (Δ waaL) prevented recognition and killing by Gal-4 and Gal-8, whereas bacteria carrying mutations that allow formation of at least one repeat of the blood group antigen (Δ wzy) remained sensitive to Gal-4 and Gal-8 (Fig. 5a-d), further illustrating the specificity of Gal-4 and Gal-8 for the blood group B antigen. Of note, lactose, but not sucrose, prevented Gal-4 and Gal-8 killing. Notably, although both Gal-4 and Gal-8 recognized BGB⁺ human erythrocytes, neither affected the membrane integrity of these cells, which indicates that the killing activity of Gal-4 and Gal-8 not only shows antigen specificity but also uniquely targets prokaryotes. Furthermore, Gal-4- and Gal-8-induced killing of BGB⁺ *E. coli* did not represent a simple agglutination-associated

reduction in colony-forming unit (CFU) counts, as Gal-4 and Gal-8 bound BGB⁺ E. coli at 4 °C but did not alter viability. In addition, both Gal-1 and human BGB-specific antibodies recognized and agglutinated BGB⁺ E. coli at high concentrations, yet failed to affect CFU counts of BGB⁺ E. coli after incubation with the bacteria.

Mice we used to test whether similar activities occur in vivo. Whether the mouse galectin-4 (Gal-4) possesses a similar ability to bind and kill BGB⁺ E. coli to human Gal-4 was examined. Recombinant mouse Gal-4 recognized BGB⁺ E. coli, and the recognition was inhibited by both lactose (Fig. 6a) and thiodigalactoside, a nonmetabolizable inhibitor of galectins. Furthermore, mouse Gal-4 recognition of BGB⁺ E. coli seemed to be specific to the BGB antigen, as mouse Gal-4 failed to recognize the Δ waaL mutant (Fig. 6b), similar to human Gal-4. Mouse Gal-4 also showed high binding of blood group antigens on the glycan microarray (Fig. 6c). Of note, mouse Gal-4 recognition of BGB⁺ E. coli resulted in a substantial reduction in viability, which seemed to be specific to BGB antigen binding, as mouse Gal-4 failed to alter the viability of the Δ waaL mutant (Fig. 6d), and Gal-4-mediated killing was inhibited by thiodigalactoside. However, mouse Gal-4-mediated killing was less potent when compared to human Gal-4, possibly owing to the reduced affinity of mouse Gal-4 for BGB when compared to BGA (Fig. 6c,d).

Example 4: Galectins specifically kill BGB⁺ bacteria in vivo

The selective killing of BGB⁺ E. coli by mouse Gal-4 suggests that the Δ waaL mutant should show better growth in vivo as a result of the inability of endogenous galectins to bind and kill these bacteria, whereas BGB⁺ E. coli should be limited in their growth owing to killing by endogenous Gal-4 and Gal-8. It has been shown that Gal-4 and Gal-8 are the only intestinal proteins that detectably bind β -galactosides, but Gal-4 and Gal-8 double-knockout mice are not available, and such mice may not be viable. Thus, to specifically test the physiological functions of these intestinal galectins, wild-type (WT) mice were fed with BGB⁺ E. coli or Δ waaL mutant E. coli. In this in vivo model, mice were treated with streptomycin to deplete endogenous bacteria followed by feeding the mice with the WT and Δ waaL mutant strains of bacteria. The number of WT bacteria detected was significantly lower in vivo compared to the Δ waaL mutant (Fig. 6e), although both types of bacteria showed equal growth kinetics in vitro, which implicated a possible galectin-mediated process in vivo. The few bacteria isolated from mice

inoculated with WT bacteria were positive for BGB antigen. Similarly, bacteria isolated after introduction of the $\Delta waaL$ mutant were negative for the BGB antigen, indicating that the bacteria examined reflected those used during the inoculation. To test the potential role of galectins in the observed difference in growth of the two types of bacteria, BGB⁺ E. coli or $\Delta waaL$ E. coli were incubated with or without the inclusion of thiodigalactoside in vivo. Although thiodigalactoside failed to alter the growth of BGB⁺ E. coli or $\Delta waaL$ E. coli in the absence of mGal-4, thiodigalactoside significantly increased BGB⁺ E. coli viability in vivo while failing to alter $\Delta waaL$ E. coli viability (Fig. 6f). These results strongly suggest that endogenous galectins specifically alter the viability of BGB⁺ E. coli in vivo. Although blood group antigens are expressed to some extent in glycosphingolipids and mucins of the gastrointestinal tract, it has been found that they are susceptible to degradation by bacterial-derived glycosidases, and in infants this bacterial-induced degradation of blood group antigens is observed soon after weaning. Thus, it is not likely that host blood group antigens, which are expressed in low amounts, can bind all of the galectins present, as Gal-4 and Gal-8 are highly expressed in the intestinal tract.

Although Gal-4 and Gal-8 seem to kill specifically BGB⁺ E. coli, whether Gal-4 or Gal-8 possess the ability to recognize and kill bacteria expressing other types of blood group antigens remained unknown. To test this, whether Gal-4 and Gal-8 could recognize and kill bacteria expressing the α 1-3Gal epitope (α -Gal E. coli), a common glycan moiety found in many mammalian species (Fig. 6g) was examined. Similar to BGB⁺ E. coli, α -Gal E. coli were recognized by Gal-4 and Gal-8 (Fig. 6h), and recognition was inhibited by thiodigalactoside. Furthermore, Gal-4 and Gal-8 recognition of α -Gal E. coli resulted in a considerable decrease in viability (Fig. 6i), although killing of α -Gal E. coli by Gal-4 and Gal-8 was reduced when compared to Gal-4- and Gal-8-mediated killing of BGB⁺ E. coli, suggesting a possible reduced binding affinity toward this glycan epitope. Consistent with this, Gal-4 and Gal-8 only recognized α -Gal epitopes on the glycan array when incubated at higher concentrations. Taken together, these results demonstrate that Gal-4 and Gal-8 possess the ability to specifically kill bacteria expressing common blood group-associated mammalian-like antigens.

Example 5: Gal-4 and Gal-8 recognize a broad range of pathogen self-like antigens

The binding of galectins to lipopoligosaccharide (LOS) molecules from a broad range of bacteria were evaluated, including some pathogenic strains, followed by printing of the LOS

structure on suitable matrices to generate a microbial glycan microarray (MGM) (Figure 7). Evaluation of Gal-4 and Gal-8 on the MGM demonstrated specific recognition of only one LOS structure, the LOS of *Providencia alcalifaciens* O5 (PAO5) (Figure 7A,B). To confirm that Gal-4 and Gal-8 specifically interact with PAO5, it was tested whether Gal-4 and Gal-8 would recognize PAO5 LOS in situ. Gal-4 and Gal-8 not only recognized the PAO5 bacteria, but did not bind PAO21 (Figure 7C-F), a related strain also printed on the MGM, and whose LOS has a similar composition but different configuration than PAO5. Furthermore, inclusion of thiodigalactoside (TDG), an inhibitor of galectin-carbohydrate interactions, prevented recognition (Figure 7C-F). Importantly, Gal-4 and Gal-8 not only recognized PAO5, but cause significant death of PAO5 over a similar range of concentrations. Similar to recognition, inclusion of TDG completely prevented Gal-4 or Gal-8 killing of PAO5 (Figure 7G-J). In addition, Gal-4 and Gal-8 failed to alter the viability of PAO21 (Figure 7I). Taken together, these results demonstrate that the MGM accurately predicts innate immune factor recognition of pathogens and suggests that PAO5 may be a previously unrecognized target for Gal-4 and Gal-8-mediated immunity.

The distinct recognition of PAO5 by Gal-4 and Gal-8 suggests that PAO5 likely possesses a unique antigenic structure recognized by these innate immune factors. Indeed, careful analysis of the MGM data demonstrated that PAO5 is the only pathogen printed on the MGM that possesses a LOS structure with potential molecular mimicry, the alpha-galactose (α -Gal) epitope. However, the ability of Gal-4 and Gal-8 to recognize α -Gal epitopes on pathogens with high affinity appears to contrast previous results utilizing the mammalian glycan microarray, and suggests that the unique self-antigen presentation on pathogens may provide high affinity interactions. Indeed, when examined at very low concentrations on the mammalian glycan microarray, Gal-4 displayed significant binding of blood group B antigens (Figure 8A). However, when examined at higher concentrations, Gal-4 and Gal-8 exhibited a wider range of self-antigen recognition, which included sialylated and terminal lactosamine containing glycans, in addition to the α -Gal epitope recognized on the MGM (Figure 8B,C). These results suggest that, in addition to killing PAO5, Gal-4 and Gal-8 may recognize other pathogens that express alternative self-like antigens.

An *in silico* approach was used in an effort to identify other potential targets which may express self-like antigens similar to those recognized by Gal-4 and Gal-8 on the mammalian

glycan microarray. To this end a relatively new searchable database of LOS structures from a diverse range of pathogenic species was utilized. Using this analysis, *Klebsiella pneumoniae* O1 (KPO1) was identified which expresses a nearly identical LOS structure as expressed by PAO5(2) (Figure 8D). To determine whether *in silico* predictions of Gal-4 and Gal-8-LOS interactions reflect actual LOS recognition, the potential binding of Gal-4 and Gal-8 toward KPO1 was examined. Gal-4 and Gal-8 recognized KPO1 and inclusion of TDG inhibited recognition (Figure 8F). Importantly, similar to their inability to recognize PA21, Gal-4 and Gal-8 failed to recognize a related strain of KP, KPO4, which possesses a LOS of similar composition as KPO1, yet fails to generate a self-like antigen. Importantly, incubation of KPO1 with either Gal-4 or Gal-8 resulted in significant loss in cell viability, while Gal-4 and Gal-8 failed to alter the viability of KPO4 (Figure 8G,H). Furthermore, inclusion of TDG prevented Gal-4 and Gal-8-induced killing (Figure 8G). These results demonstrate that this *in silico* approach can identify additional targets for Gal-4 and Gal-8-mediated immunity of pathogens bearing self-like antigens.

As this *in silico* approach appeared to predict Gal-4 and Gal-8-pathogen interactions, whether Gal-4 or Gal-8 might provide immunity against pathogens which bear other commonly occurring carbohydrate antigens was investigated. To accomplish this, pathogens were searched that generate sialylated carbohydrate antigens, one of the most common monosaccharide modifications on the surface of mammalian cells. *In silico* analysis identified a nontypeable *Haemophilus influenzae* (NTHi) 2019 as a pathogen that expresses both terminal sialylated and lactosamine antigens. Consistent with the predicted recognition based on the carbohydrate binding properties of Gal-4 and Gal-8 on the mammalian glycan microarray and *in silico* analysis, Gal-4 and Gal-8 displayed significant recognition of NTHi 2019. Furthermore, incubation of Gal-4 and Gal-8 with NTHi 2019 resulted in significant loss of viability (Figure 8I-K). Inclusion of TDG not only prevented Gal-4 and Gal-8 recognition of NTHi 2019, but also inhibited Gal-4 and Gal-8-induced killing. Importantly, Gal-4 and Gal-8 failed to recognize or kill strains of NTHi that fail to express sialylated and lactosamine related antigens (Figure 8J). These results demonstrate that Gal-4 and Gal-8 can recognize and kill bacteria expressing sialylated and terminal lactosamine-containing glycans.

Most innate immune lectins and effector molecules of the adaptive immune system recognize unique determinants that appear to specifically reside on the surface of a targeted

pathogen. Indeed, discrimination of self from non-self at the level of ligand recognition by immune factors likely plays a major role in the ability of immunity to specifically target pathogens. However, the ability of Gal-4 and Gal-8 to not only recognize, but to apparently exclusively recognize self-like antigens stands in stark contrast to other innate immune factors and suggests that Gal-4 and Gal-8 may actually induce similar changes, such as loss of membrane integrity, in mammalian cells. However, while Gal-4 and Gal-8 induced significant loss in viability of PAO5, KPO1, and NTHi 2019, incubation of Gal-4 or Gal-8 with murine erythrocytes, wt CHO or Lec 2 CHO cells which express α -Gal, sialylated or LacNAc terminal glycans respectively (Figure 9A), failed to induce any detectable changes in membrane integrity despite their ability to recognize each of these mammalian cells in a carbohydrate dependent fashion (Figure 9B-F). Importantly, significant changes in membrane architecture accompanied Gal-4 and Gal-8-induced loss of bacterial viability (Figure 9G-J). Taken together, these results demonstrate that Gal-4 and Gal-8 have an unprecedented ability to discriminate pathogens versus self while recognizing very similar antigenic structures.

Example 6: Gal-7 and Gal-9 recognize and kill selected strains of bacteria expressing host-like antigens.

In addition to observed killing by the “tandem repeat galectins”, galectin-4 and galectin-8, recent data also implicates tandem repeat galectin-9 (Gal-9) as well as “prototypical” galectin-7 (Gal-7) have direct killing activity as innate immune lectins. Both Gal-7, as well as both the N and C CRD domains of Gal-9, demonstrate specificity for blood group structures on the glycan microarray of the Consortium for Functional Glycomics. In addition Gal-7 and Gal-9 are able to bind directly to blood group positive *Escherichia coli* as well as blood group-like structures on other bacterial strains shown to be targeted by Gal-4 and Gal-8. Incubation of these bacterial strains with either Gal-7 or the Gal-9 domains results in almost complete loss of viability. In addition, further study of Gal-7 killing has demonstrated a similar kinetics, potency, and changes in bacterial membrane morphology to that observed after incubation with Gal-4 or Gal-8.

Methods

Preparation of recombinant human galectins.

Gal-1, Gal-3, Gal-4, Gal-4 domains, Gal-8, Gal-7, Gal-8 domains and Gal-8 mutants, and Gal-9 were prepared as outlined in Stowell et al., *J. Biol. Chem.* 283, 10109–10123 (2008) and Stowell et al., *Mol. Biol. Cell* 20, 1408–1418 (2009) hereby incorporated by reference. Gal-8R69H and Gal-8R233H were generated with appropriate primers as described in Stowell et al., *J. Biol. Chem.* 283, 20547–20559 (2008) hereby incorporated by reference. Galectins were purified to apparent homogeneity by affinity chromatography on lactosyl-Sepharose (Sigma) as observed by SDS-PAGE. To aid in detection, all galectins were derivatized by addition of EZ-link Sulfo-NHS-LC-Biotin (Sulfosuccinimidyl-6-(biotinamido) hexanoate) (Pierce).

Glycan microarray preparation and analysis.

Glycan microarrays were obtained from the Consortium for Functional Glycomics (<http://www.functionalglycomics.org/>) that were prepared as described in Blixt, O. et al., *Proc. Natl. Acad. Sci. USA* 101, 17033–17038 (2004) hereby incorporated by reference.

Flow cytometric analysis.

To examine potential binding by each galectin, bacteria were grown to mid-log phase in LB medium (Fisher), and resuspended 1×10^8 cells per ml in PBS pH 7.4 with biotinylated Gal-1, Gal-3, Gal-4, Gal-4 domains, Gal-8, Gal-8 domains or mutant Gal-4 at concentrations of ~ 0.1 μ M at 4 °C for 30 min. As a control, bacteria were also incubated with 20 mM lactose (Fisher) along with galectins. After incubation, the bacteria were washed three times and incubated them with Alexa Fluor-488–conjugated streptavidin or Alexa Fluor-633–conjugated streptavidin (Molecular Probes) at 4 °C for 30 min. Bacteria were washed two times and resuspended them in 400 μ L PBS for analysis by flow cytometry with a FACSCalibur flow cytometer (BD Biosciences). Results were analyzed with CellQuest software (BD Biosciences).

Growth and treatment of bacteria.

E. coli O86 (BGB⁺ *E. coli*), were received as well as mutant strains and α -Gal *E. coli*, from Ohio State University. Clinical reference strains were obtained, including the two blood group–negative strains of *E. coli* (American Type Culture Collection (ATCC) 25922 and ATCC 35218), *K. pneumoniae* (ATCC 700603), *P. aeruginosa* (ATCC 27853) and *S. aureus* (ATCC 29213) from the Emory University Clinical Microbiology lab. When assaying potential

antimicrobial effects of galectins, all bacteria were grown to mid-log phase in LB media (Fisher) and incubated 1×10^8 cells per mL with the concentrations of each galectin indicated in the figures for 2 h at 37 °C, unless otherwise indicated. After incubation with each respective galectin, the number of viable bacteria were determined by dilution plating and CFU enumeration. 20 mM lactose or sucrose was typically incubated with the galectin for 10 min before incubation with bacteria.

Mixed population.

To assess the specificity of Gal-8-mediated killing in a mixed population, BGB⁺ *E. coli* was mixed with GFP-expressing *P. aeruginosa* (Supplementary Methods) in a 4:1 ratio. This mixture was incubated in the presence or absence of Gal-8 for 2 h at 37 °C followed by dilution plating for CFU enumeration or flow cytometric examination of percentage GFP-positive cells.

Preparation for visual analysis.

Either PBS control or 5 μ M Gal-8 at 37 °C was added to BGB⁺ *E. coli* grown to log phase. BGB⁺ *E. coli* were incubated for 30 min with PBS control or 5 μ M Gal-8 at 37 °C. 20 mM lactose was added to halt treatment and reduce agglutination. Bacteria were washed one time with PBS and centrifuged at 20,000g in a table-top centrifuge. Bacteria were resuspended in PBS and added 1 μ l of propidium iodide solution (1 in 20 dilution of propidium iodide from Live/Dead viability kit (Invitrogen) to PBS). Bacteria were incubated in the dark at 22 °C for 30 min and visualized by fluorescence microscopy at 100 \times magnification.

Mouse studies.

Experiments were conducted in accordance with the guidelines of the Animal Care Committee from the University of Sao Paulo (protocol number 09.1.543.53.5). C57BL/6 specific pathogens-free mice were obtained from the animal facilities of the Faculdade de Ciências Farmacêuticas de Ribeirão Preto, Universidade de São Paulo. For in vivo experiments, mice were treated with streptomycin (5 g l⁻¹) for 48 h. The mice were then fed with either WT BGB⁺ or Δ waaL *E. coli* with or without addition of thiodigalactoside. After 24 h, the mice were killed and the number of viable bacteria were determined in the intestine by dilution plating and CFU enumeration.

CLAIMS

1. Use of a purified galectin to kill bacteria and other pathogens.
2. A method of treating or preventing an infectious disease comprising administering a purified lectin to a subject at risk of, exhibiting symptoms of, or diagnosed with a pathogenic infection.
3. The method of Claim 2, wherein the subject is a human subject.
4. The method of Claim 2, wherein the lectin is Gal-4, Gal-7, Gal-8, Gal-9 or active fragments thereof.
5. The method of Claim 4, wherein a fragment of Gal-4, Gal-8, and Gal-9 comprises a C-terminal carbohydrate recognition domain.
6. The method of Claim 4, wherein a fragment of Gal-9 comprises an N-terminal carbohydrate recognition domain.
7. The method of Claim 6, wherein the human blood group antigen is A, B, H, an Rh glycoprotein or combination thereof.
8. The method of Claim 2, wherein the subject is diagnosed with blood type B.
9. The method of Claim 2, wherein the pathogen is a bacteria, virus, or fungus.
10. The method of Claim 9, wherein the bacteria is selected from the group consisting of *Acinetobacter baumannii*, *Bordetella pertussis*, *Burkholderia cepacia*, *Burkholderia pseudomallei*, *Burkholderia mallei*, *Campylobacter jejuni*, *Campylobacter coli*, *Enterobacter cloacae*, *Enterobacter aerogenes*, *Escherichia coli*, *Francisella tularensis*, *Haemophilus influenzae*, *Haemophilus ducreyi*, *Helicobacter pylori*, *Klebsiella pneumoniae*, *Legionella pneumophila*, *Moraxella catarrhalis*, *Morganella morganii*, *Neisseria gonorrhoeae*, *Neisseria*

procain, spectinomycin, tinidazole, trimethoprim, ramoplanin, teicoplanin, vancomycin, trimethoprim, sulfamethoxazole, and/or nitrofurantoin.

13. The method of Claim 9, wherein the virus is influenza A virus including subtype H1N1, influenza B virus, influenza C virus, rotavirus A, rotavirus B, rotavirus C, rotavirus D, rotavirus E, SARS coronavirus, human adenovirus types (HAdV-1 to 55), human papillomavirus (HPV) Types 16, 18, 31, 33, 35, 39, 45, 51, 52, 56, 58, and 59, parvovirus B19, molluscum contagiosum virus, JC virus (JCV), BK virus, Merkel cell polyomavirus, coxsackie A virus, norovirus, Rubella virus, lymphocytic choriomeningitis virus (LCMV), yellow fever virus, measles virus, mumps virus, respiratory syncytial virus, rinderpest virus, California encephalitis virus, hantavirus, rabies virus, ebola virus, marburg virus, herpes simplex virus-1 (HSV-1), herpes simplex virus-2 (HSV-2), varicella zoster virus (VZV), Epstein-Barr virus (EBV), cytomegalovirus (CMV), herpes lymphotropic virus, roseolovirus, or Kaposi's sarcoma-associated herpesvirus, hepatitis A, hepatitis B, hepatitis C, hepatitis D, hepatitis E or human immunodeficiency virus (HIV).

14. The method of Claim 2, wherein the purified galectin is administered in combination with one or more antiviral agents.

15. The method of Claim 13, wherein the antiviral agent is abacavir, acyclovir, acyclovir, adefovir, amantadine, amprenavir, ampligen, arbidol, atazanavir, atripla, boceprevir, cidofovir, combivir, darunavir, delavirdine, didanosine, docosanol, edoxudine, efavirenz, emtricitabine, enfuvirtide, entecavir, famciclovir, fomivirsen, fosamprenavir, foscarnet, fosfonet, ganciclovir, ibacitabine, imunovir, idoxuridine, imiquimod, indinavir, inosine, interferon type III, interferon type II, interferon type I, lamivudine, lopinavir, loviride, maraviroc, moroxydine, methisazone, nelfinavir, nevirapine, nexavir, oseltamivir (Tamiflu), peginterferon alfa-2a, penciclovir, peramivir, pleconaril, podophyllotoxin, raltegravir, ribavirin, rimantadine, ritonavir, pyrimidine, saquinavir, stavudine, tenofovir, tenofovir disoproxil, tipranavir, trifluridine, trizivir, tromantadine, truvada, valaciclovir (Valtrex), valganciclovir, vicriviroc, vidarabine, viramidine, zalcitabine, zanamivir (Relenza), and/or zidovudine (AZT).

16. A pharmaceutical composition comprising a Gal-4, Gal-7, Gal-8, Gal-9 or active fragments thereof provided the galectin comprises a C-terminal carbohydrate recognition domain.

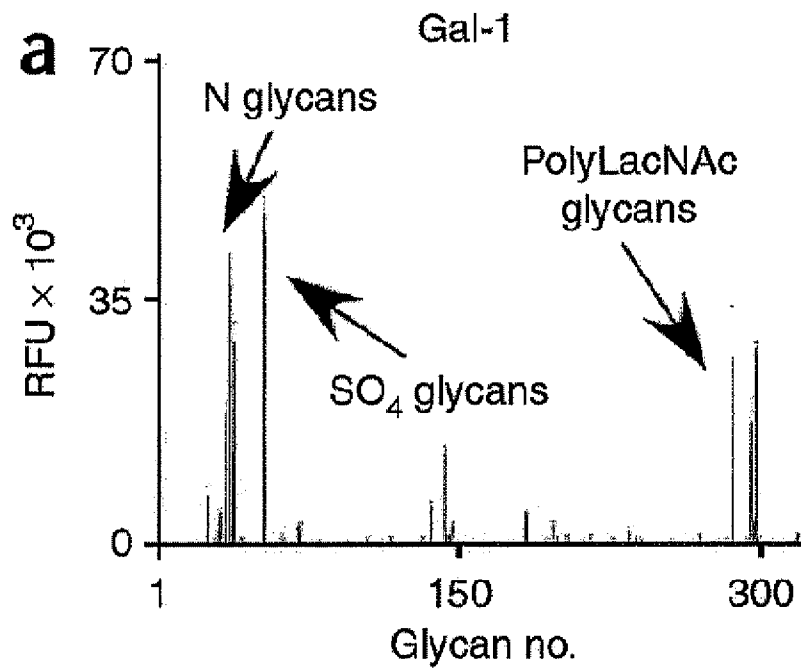

FIGURE 1A

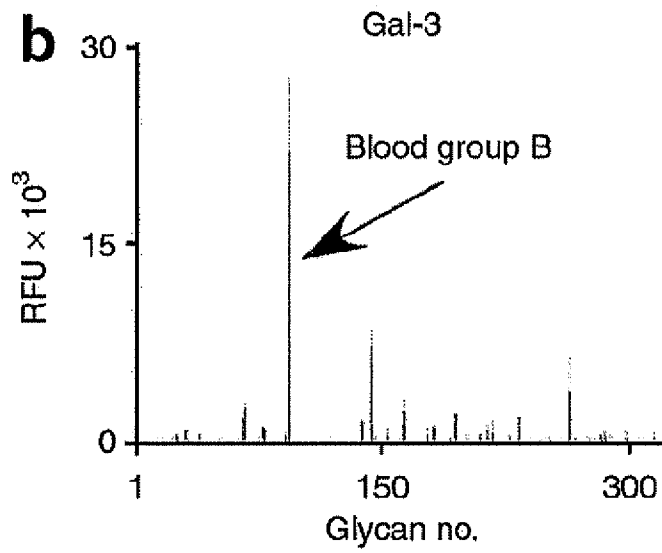

FIGURE 1B

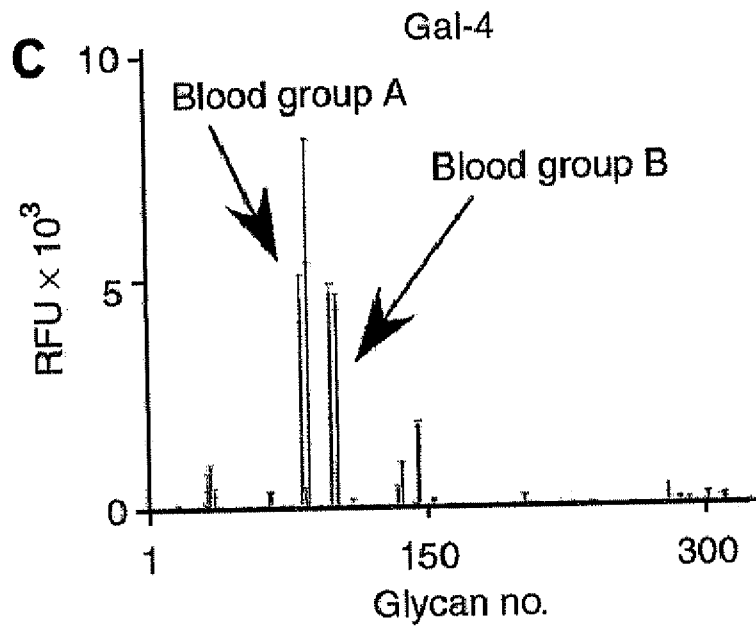

FIGURE 1C

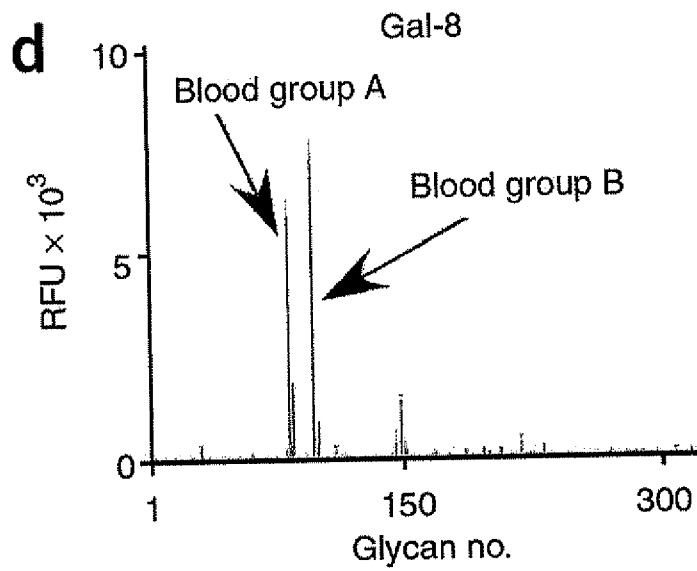

FIGURE 1D

e

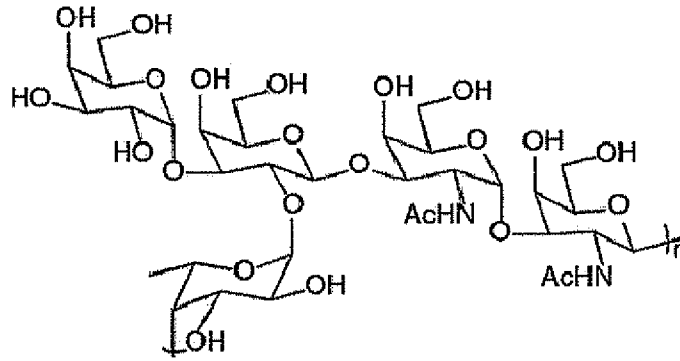

FIGURE 1E

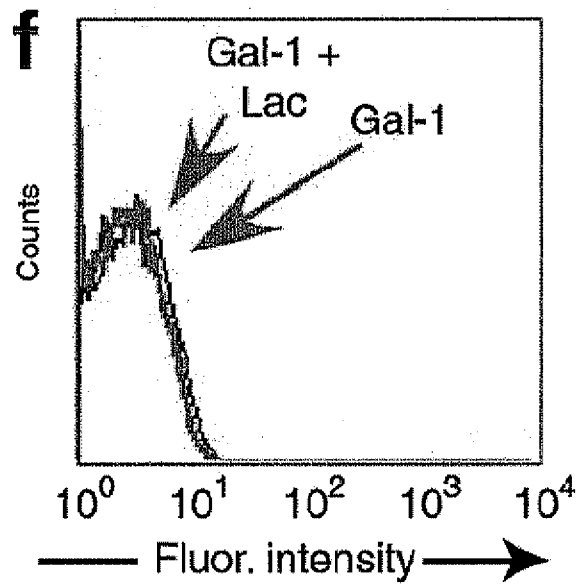

FIGURE 1F

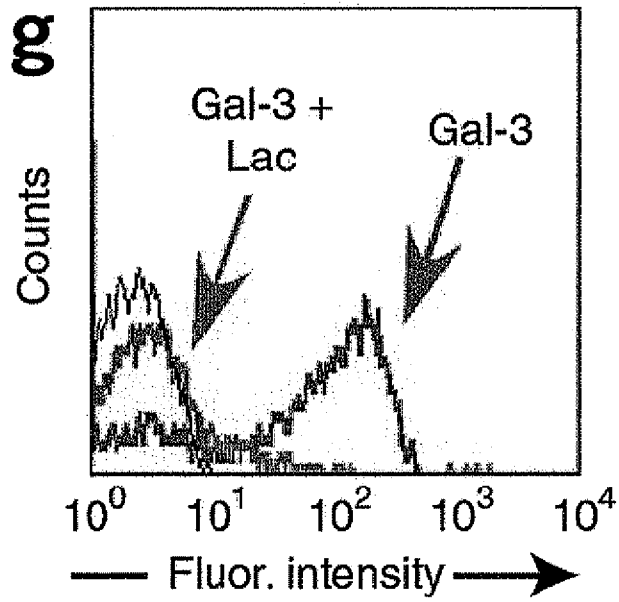

FIGURE 1G

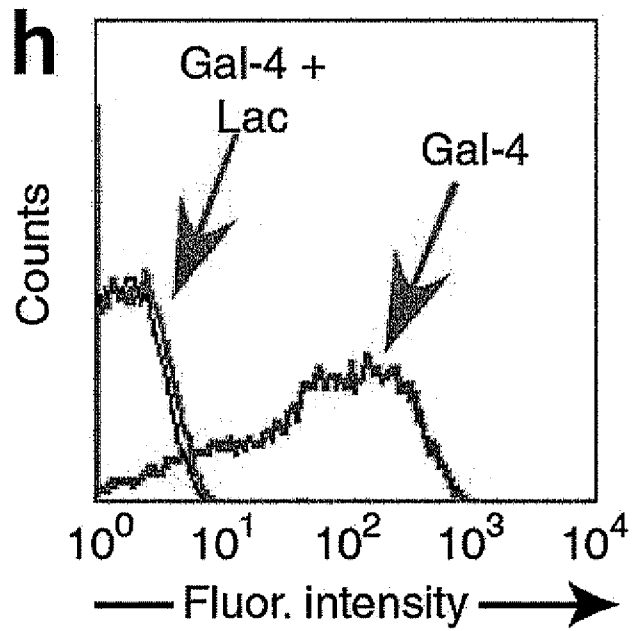

FIGURE 1H

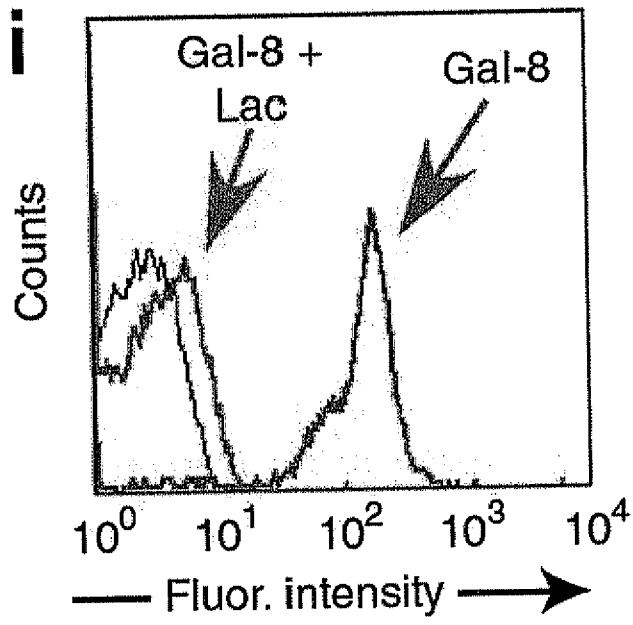

FIGURE II

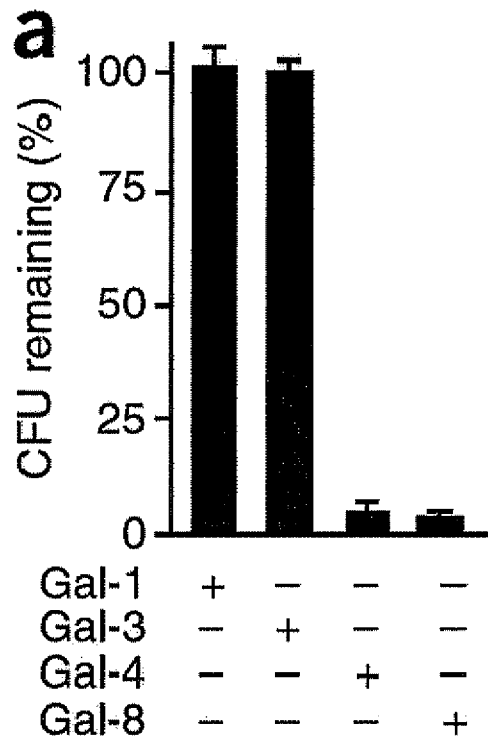

FIGURE 2A

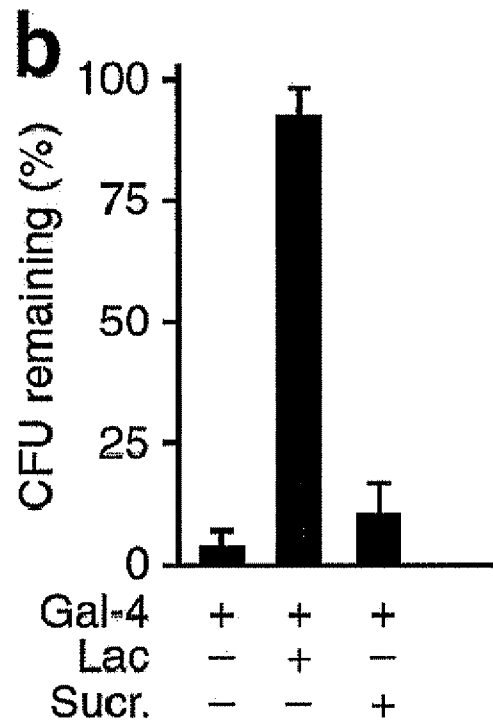

FIGURE 2B

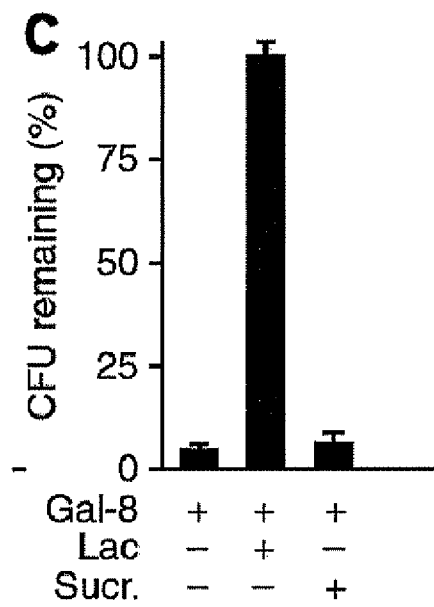

FIGURE 2C

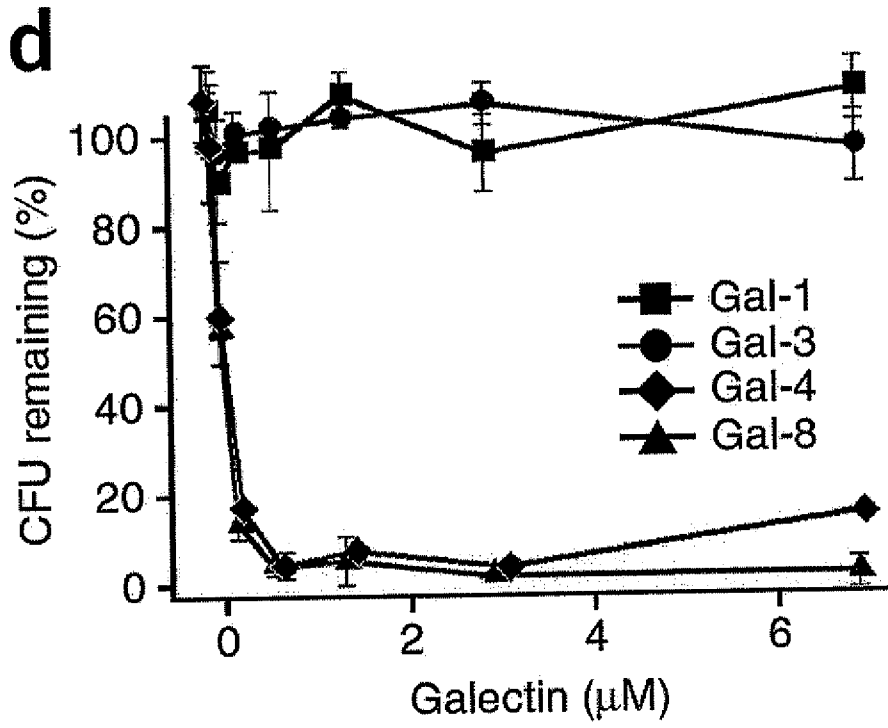

FIGURE 2D

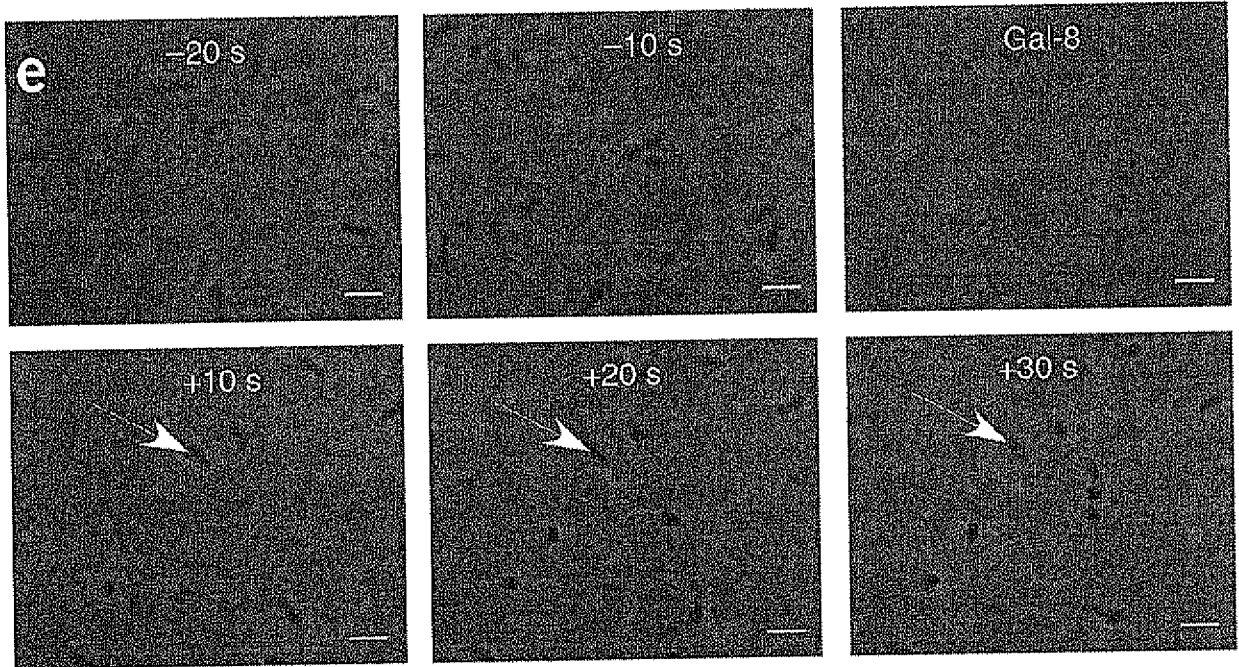

FIGURE 2E

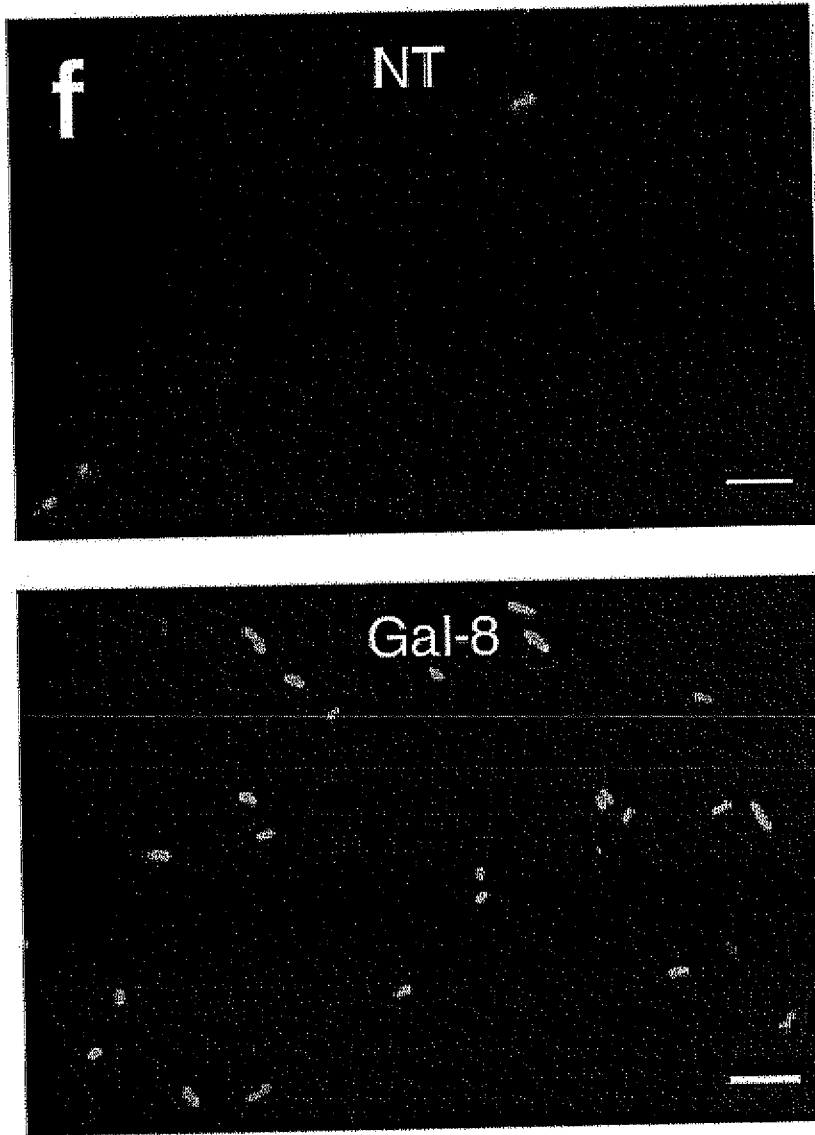

FIGURE 2F

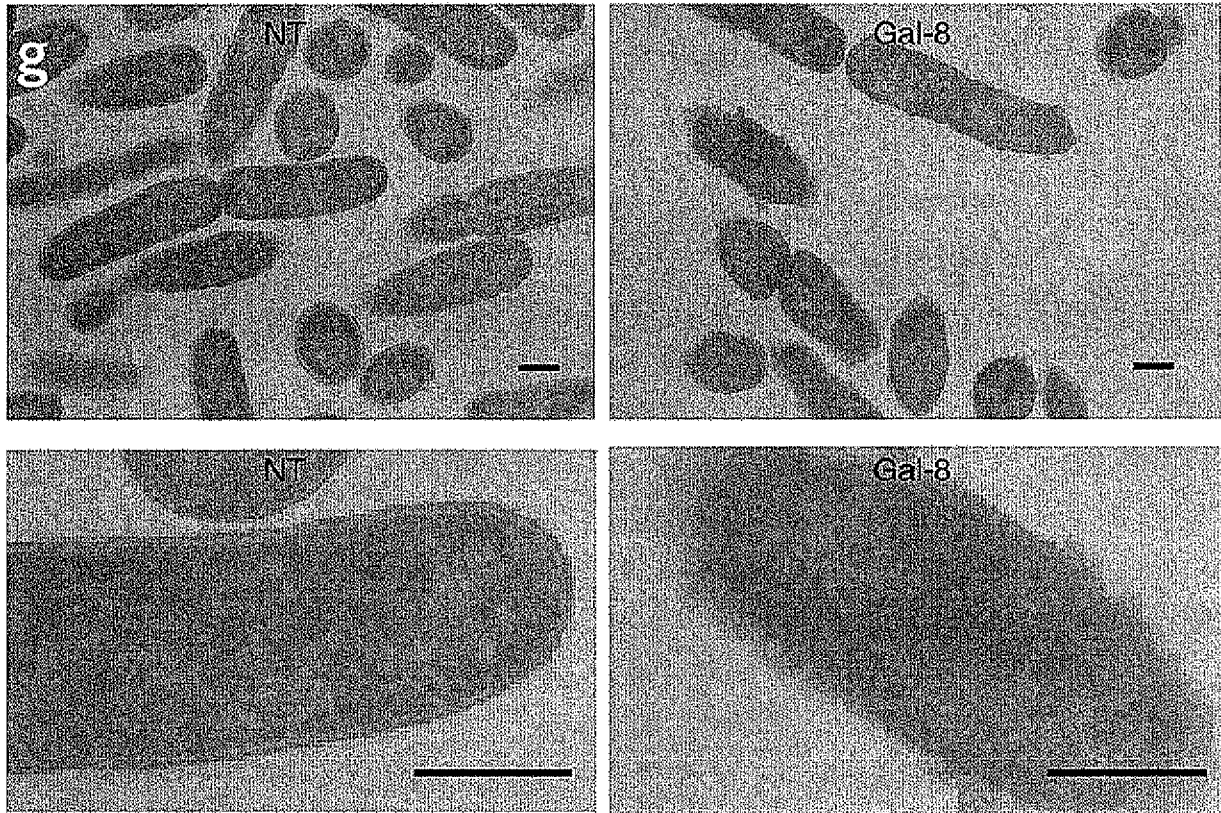

FIGURE 2G

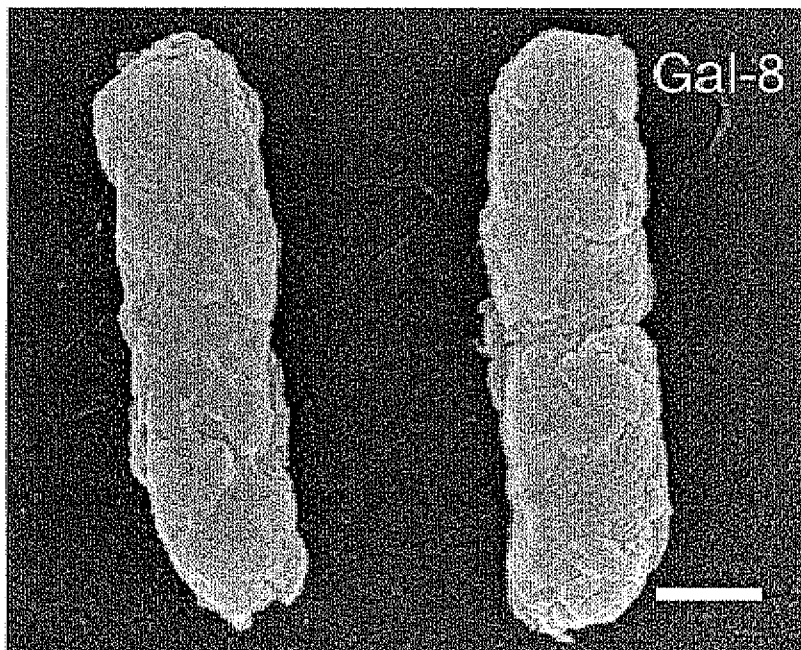
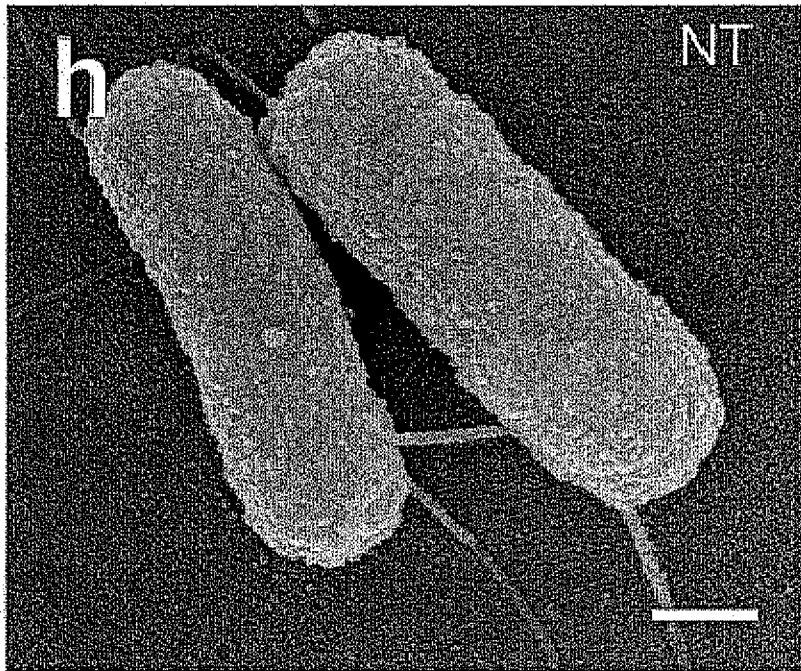

FIGURE 2H

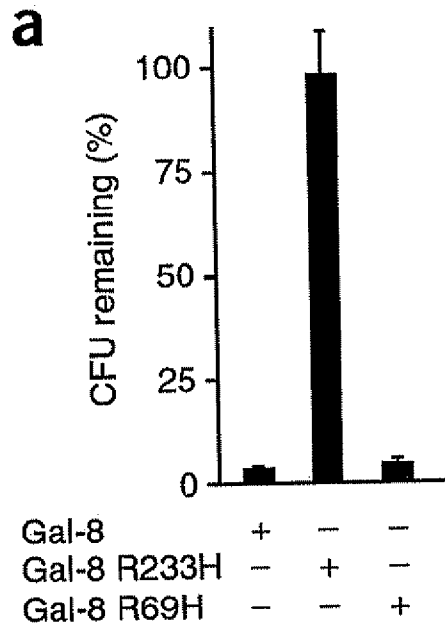

FIGURE 3A

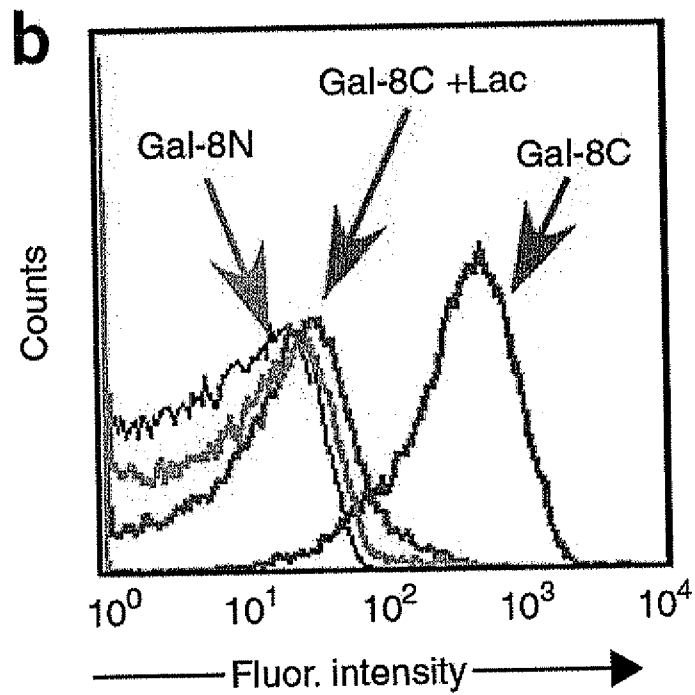

FIGURE 3B

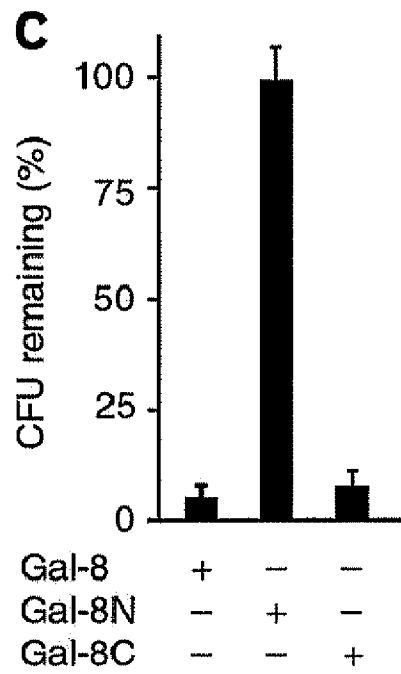

FIGURE 3C

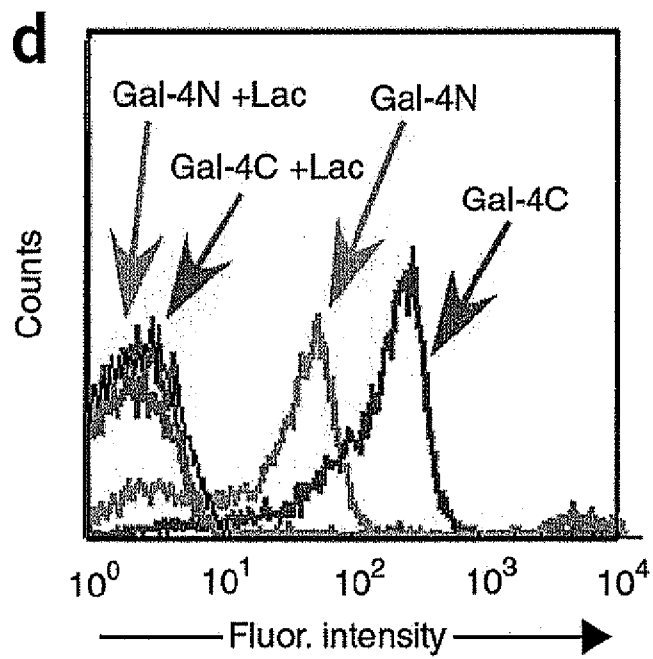

FIGURE 3D

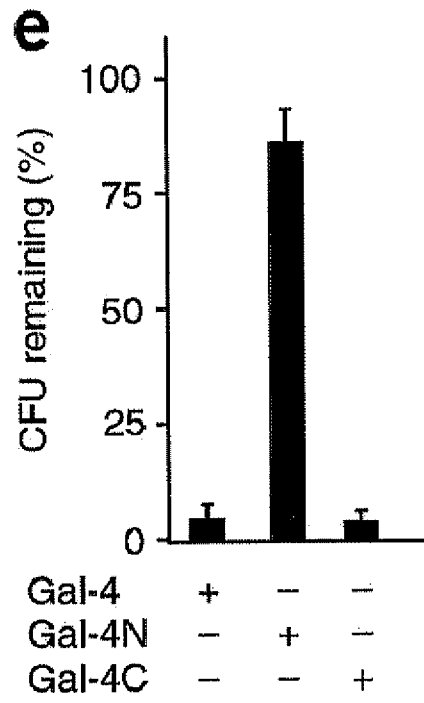

FIGURE 3E

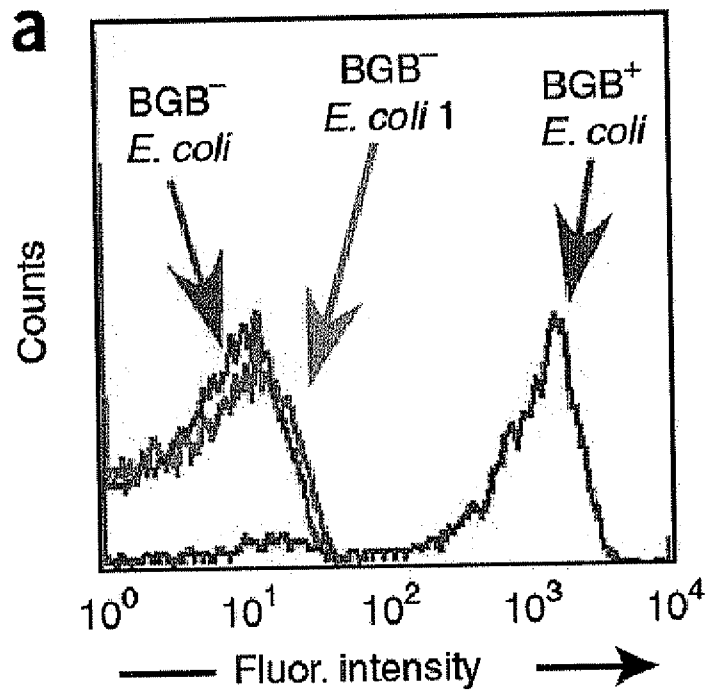

FIGURE 4A

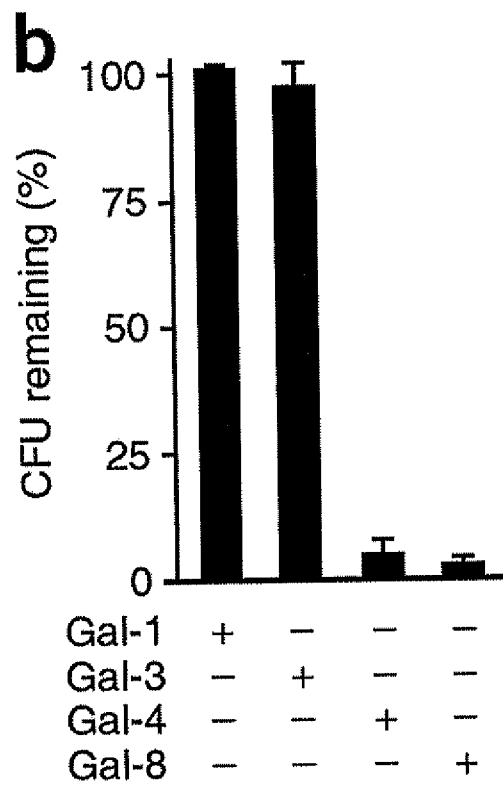

FIGURE 4B

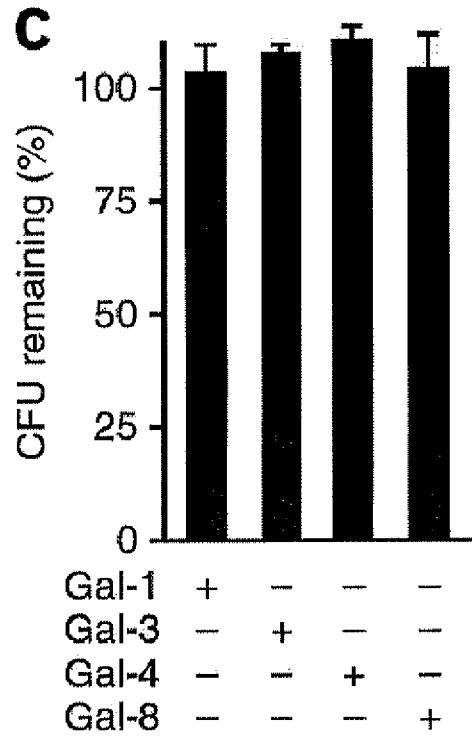

FIGURE 4C

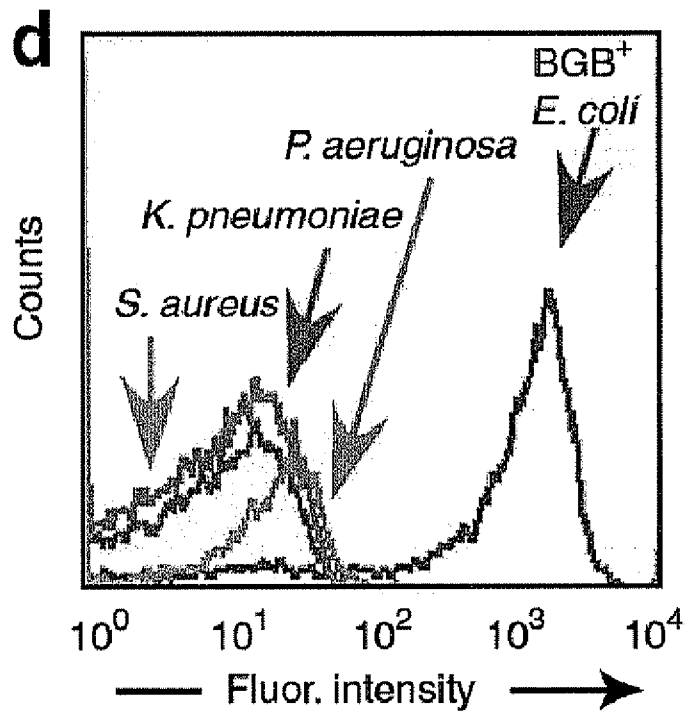

FIGURE 4D

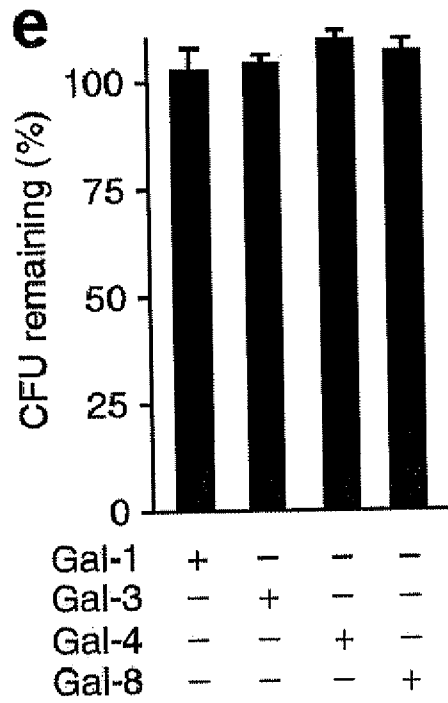

FIGURE 4E

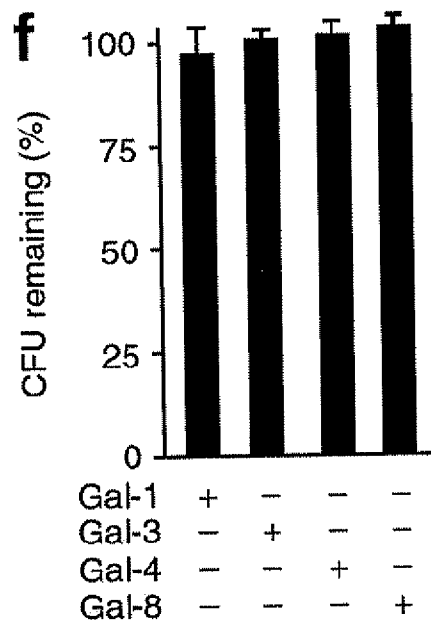

FIGURE 4F

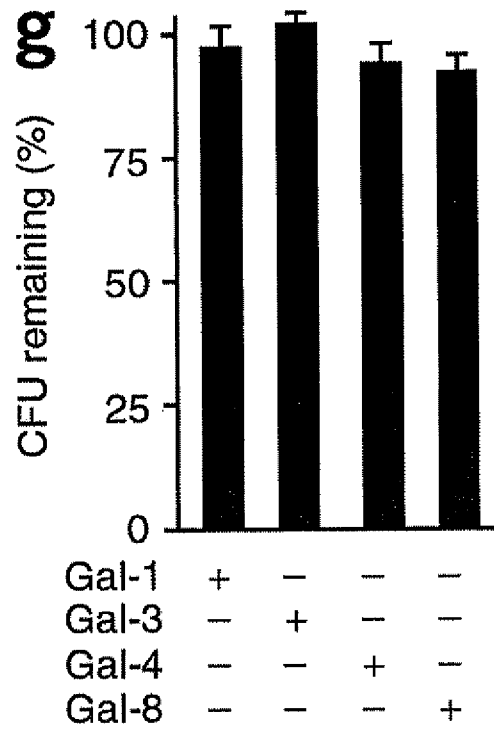

FIGURE 4G

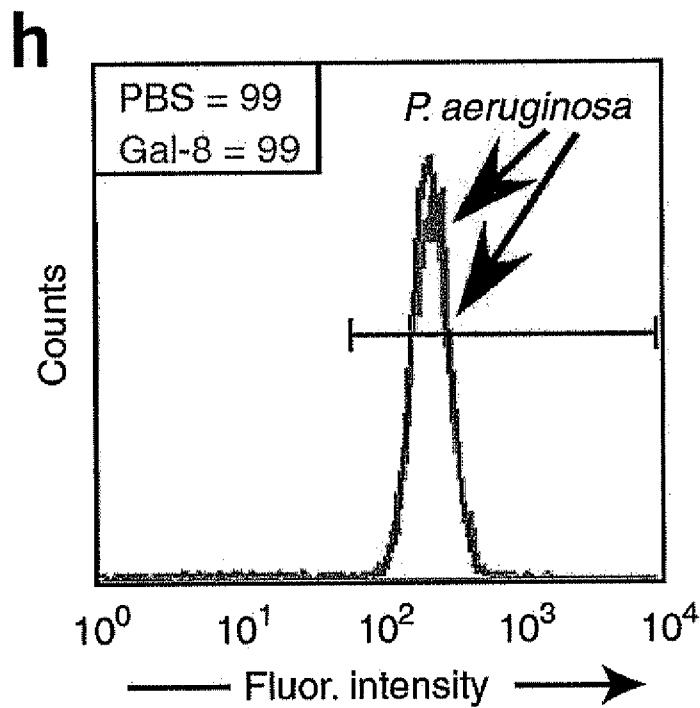

FIGURE 4H

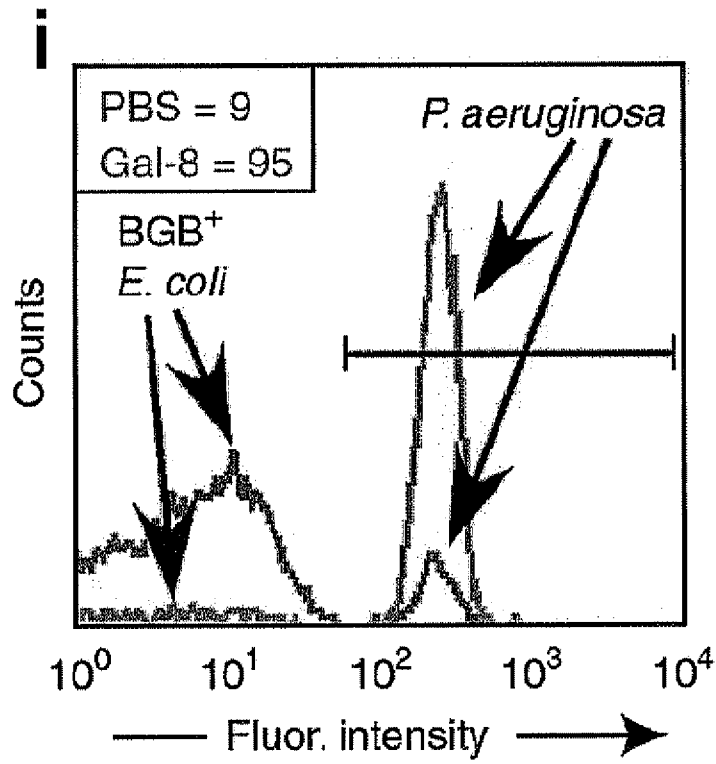

FIGURE 4I

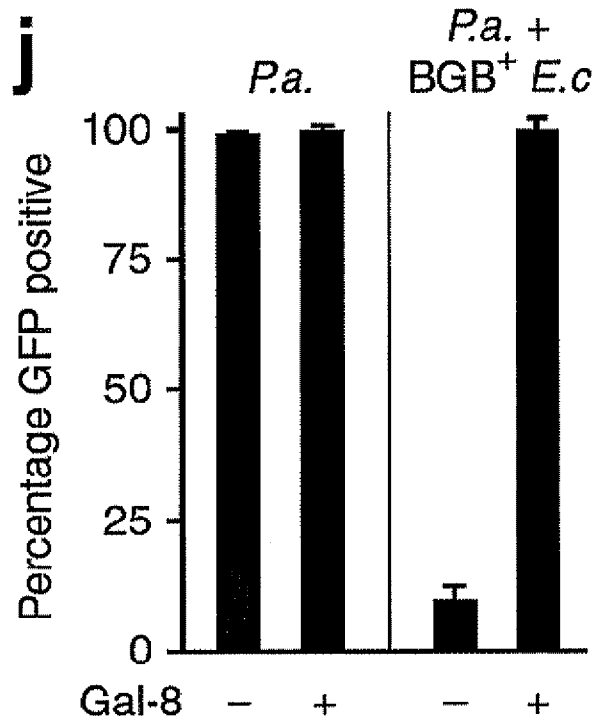

FIGURE 4J

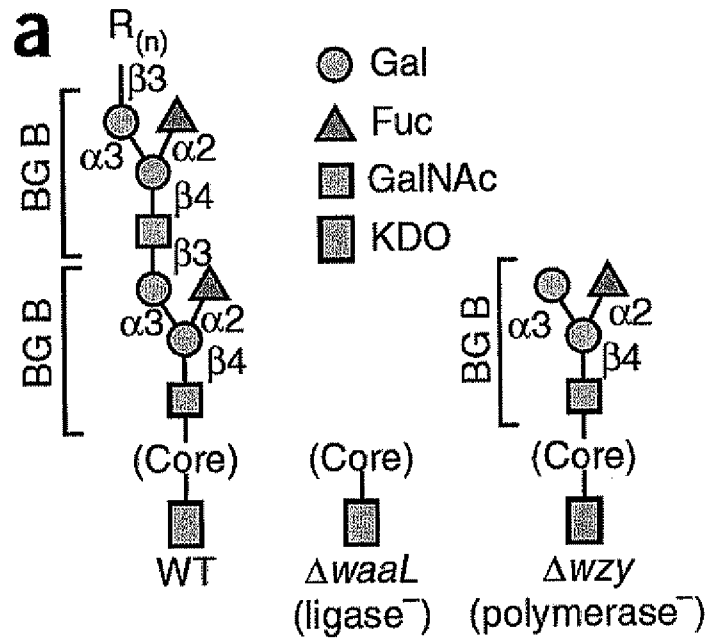

FIGURE 5A

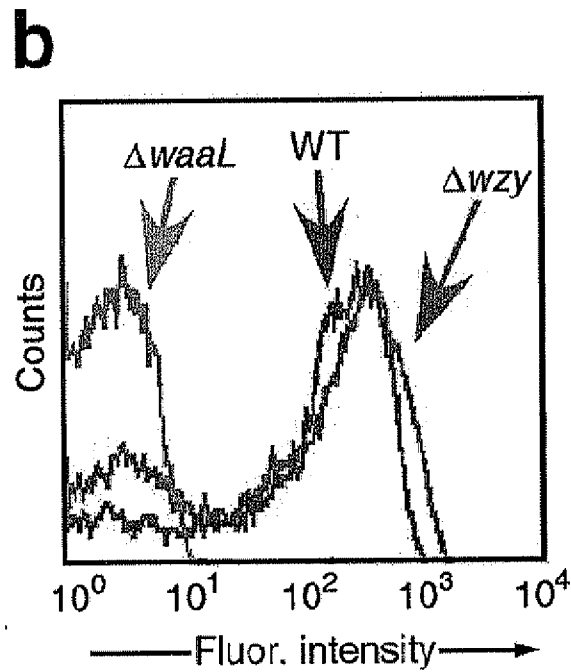

FIGURE 5B

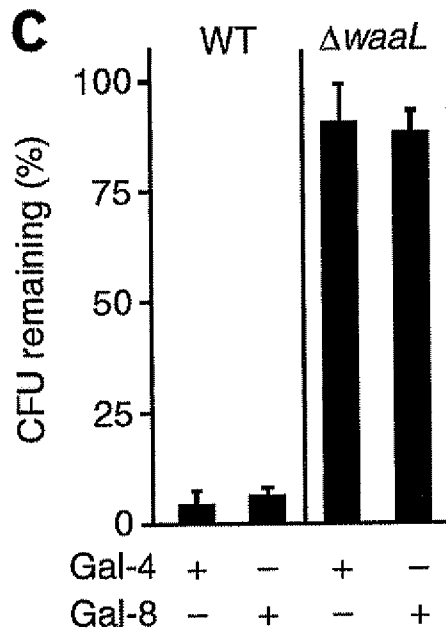

FIGURE 5C

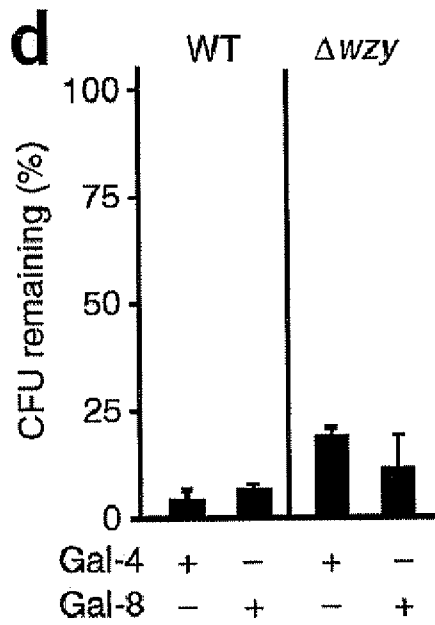

FIGURE 5D

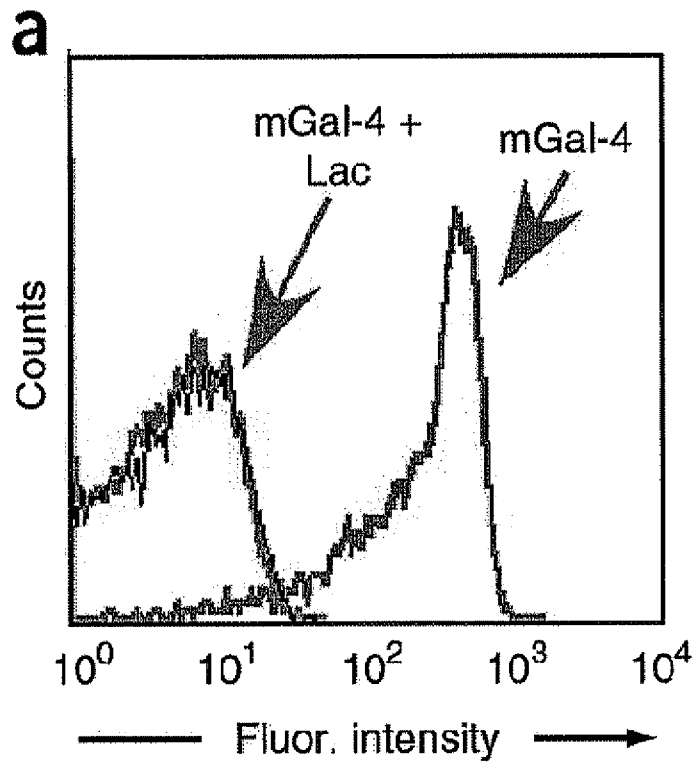

FIGURE 6A

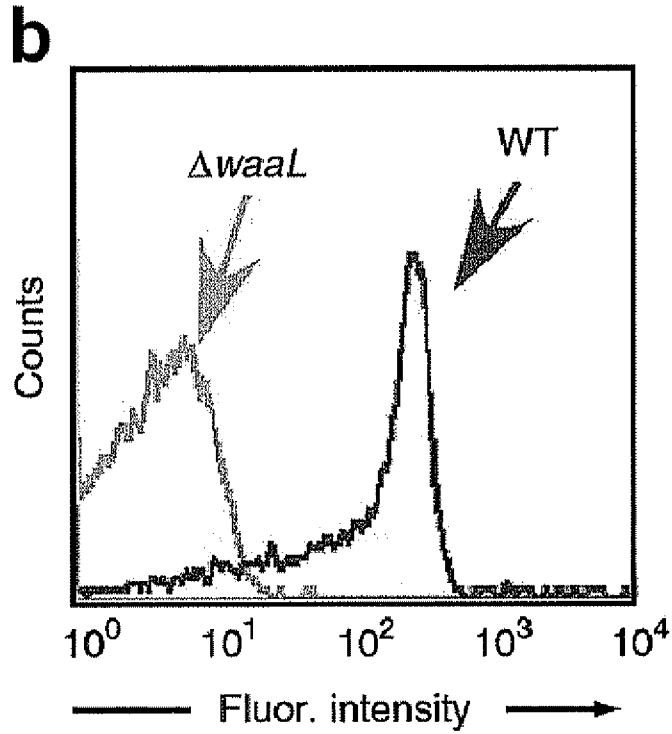

FIGURE 6B

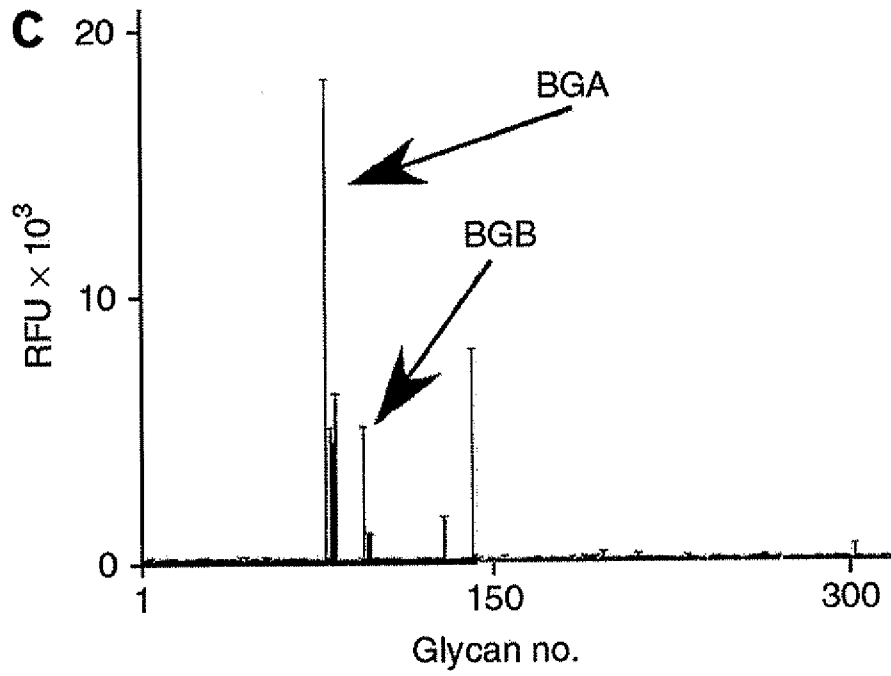

FIGURE 6C

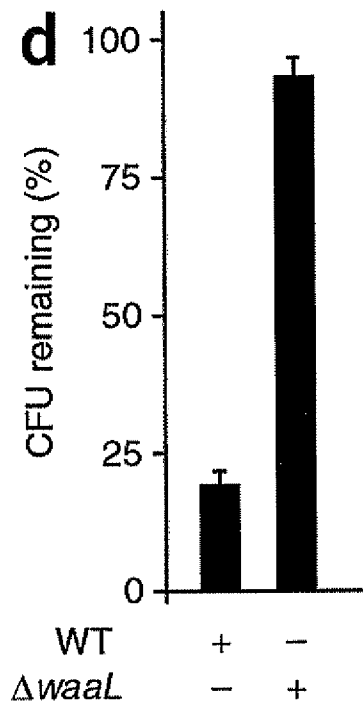

FIGURE 6D

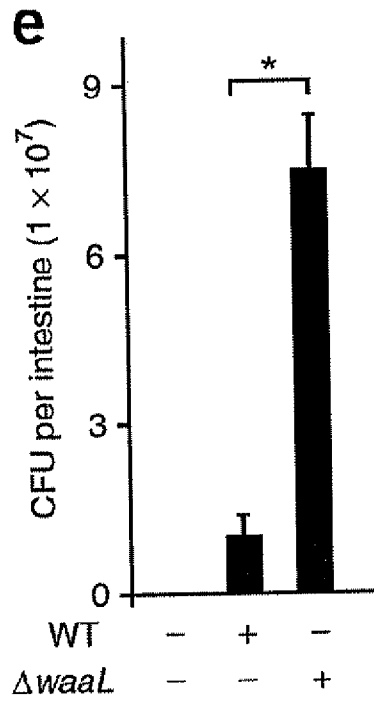

FIGURE 6E

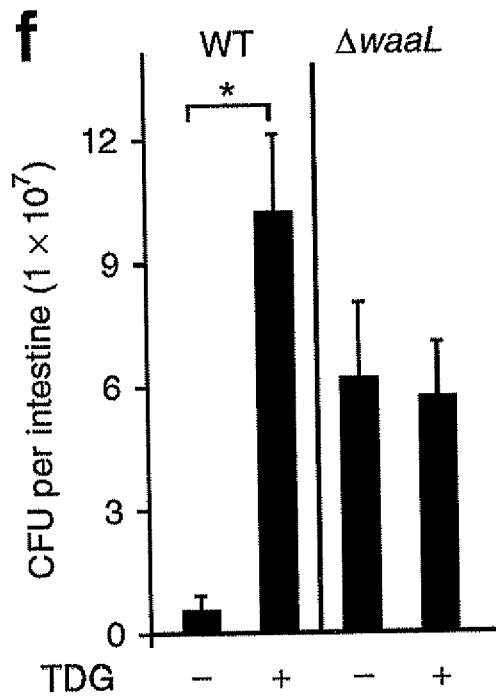

FIGURE 6F

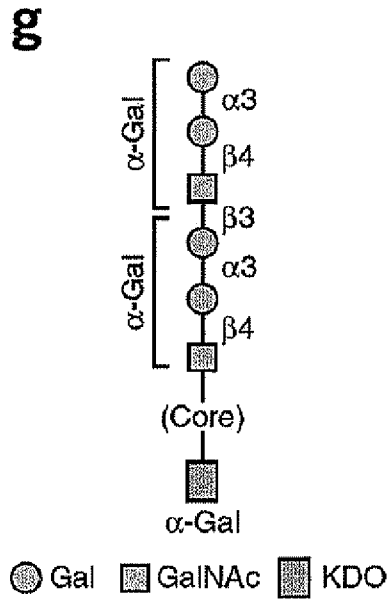

FIGURE 6G

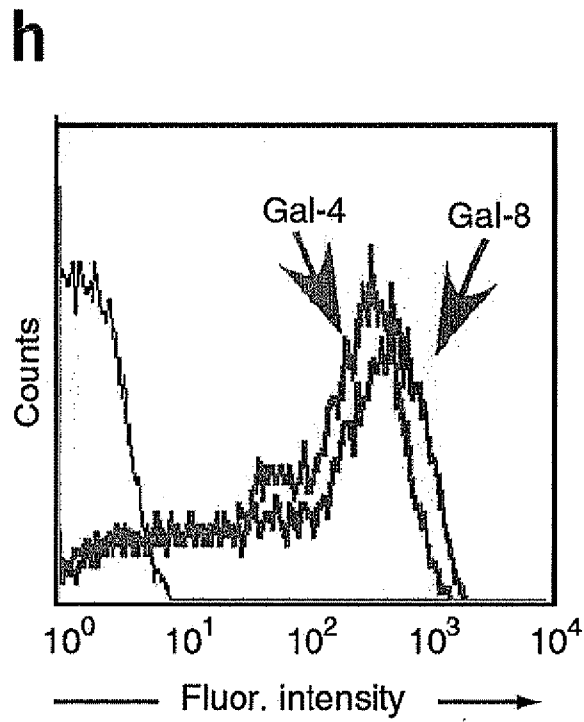

FIGURE 6H

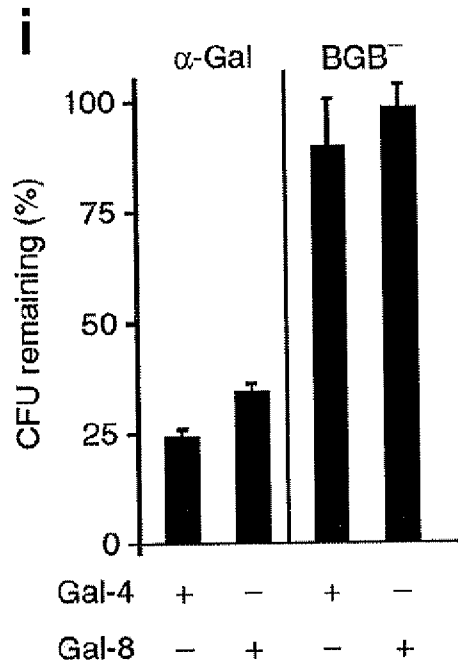

FIGURE 6I

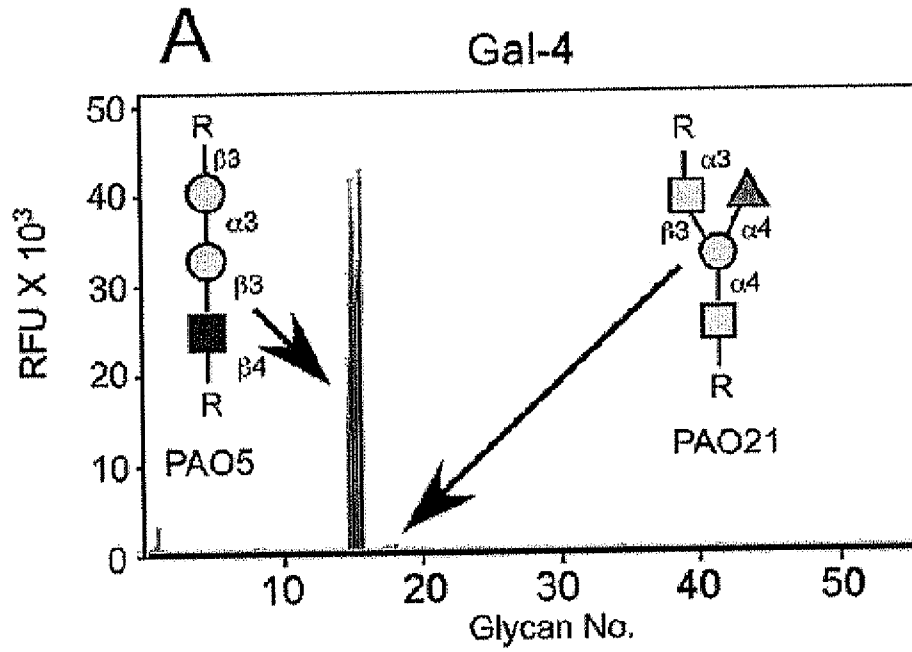

FIGURE 7A

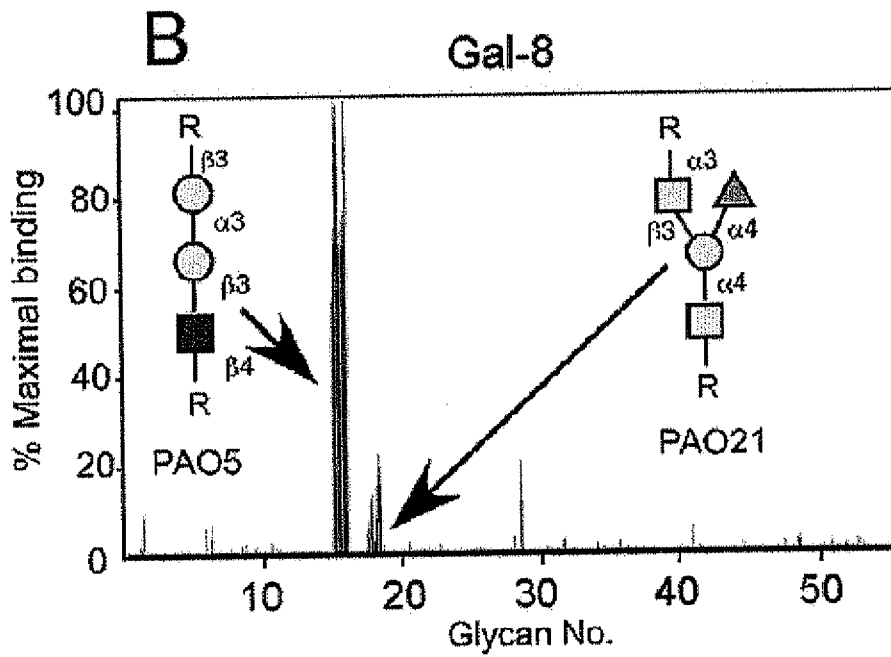

FIGURE 7B

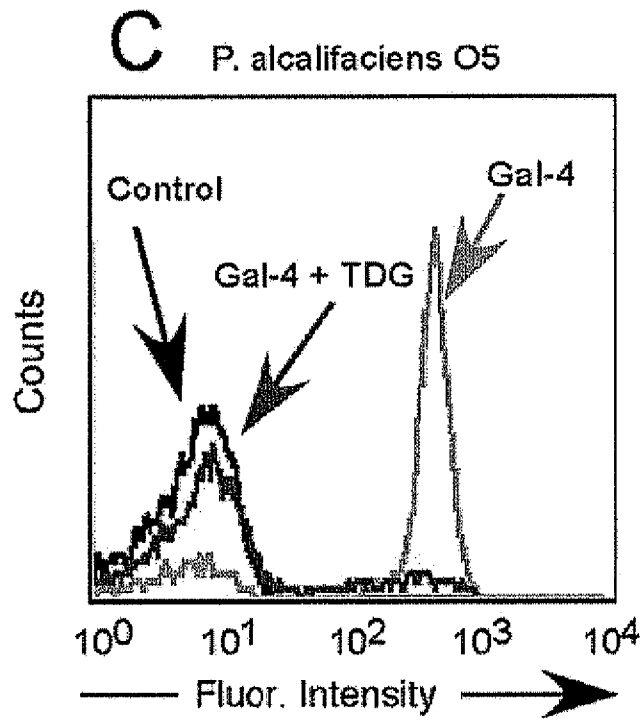

FIGURE 7C

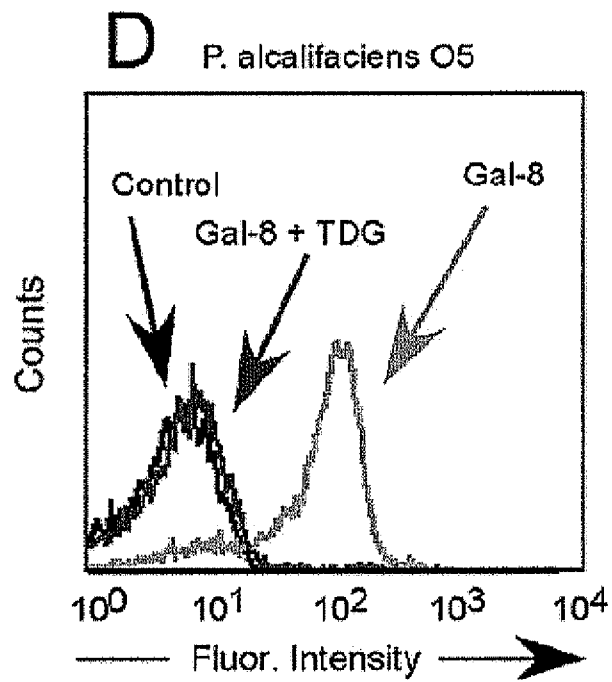

FIGURE 7D

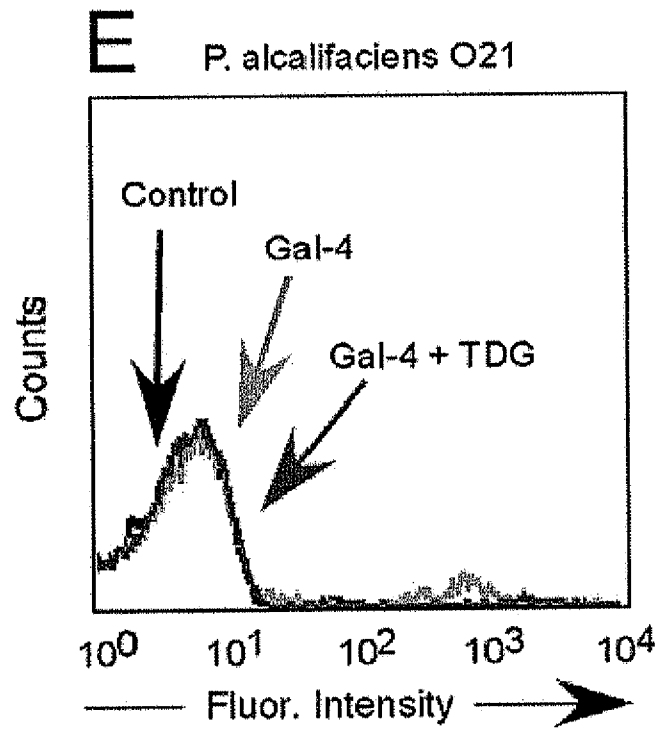

FIGURE 7E

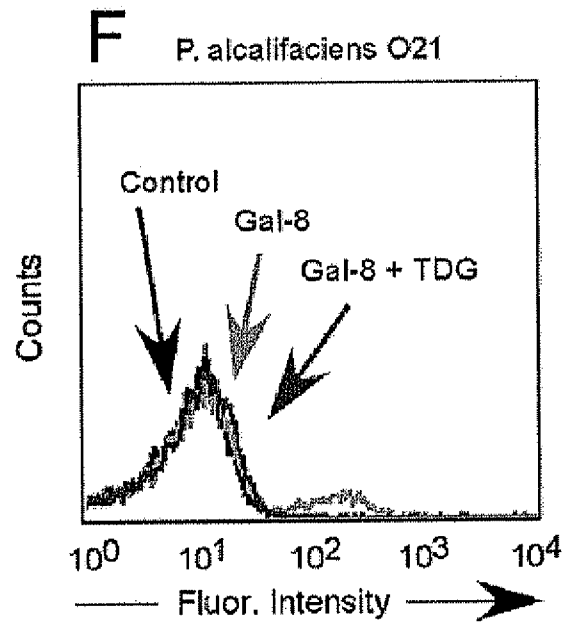

FIGURE 7F

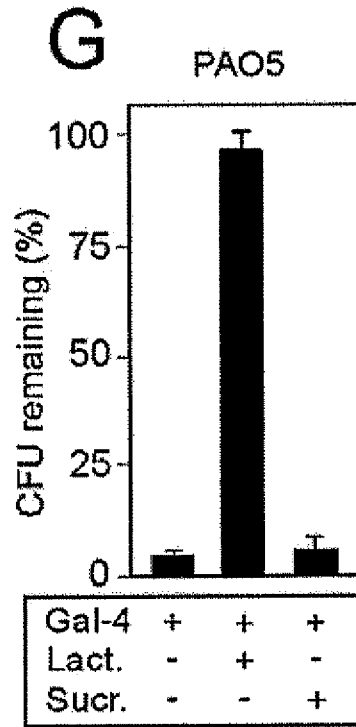

FIGURE 7G

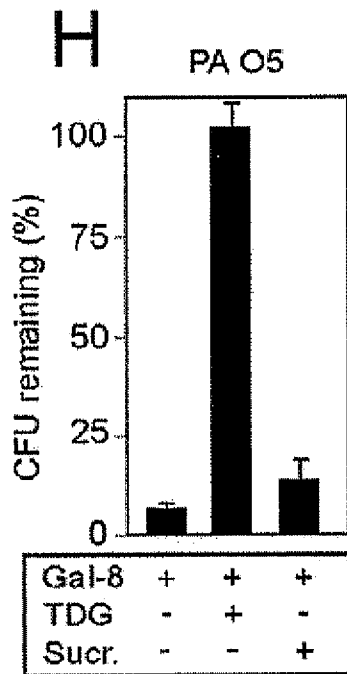

FIGURE 7H

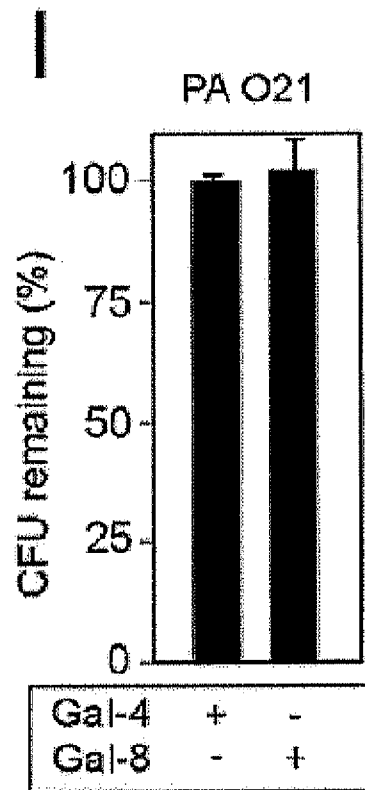

FIGURE 7I

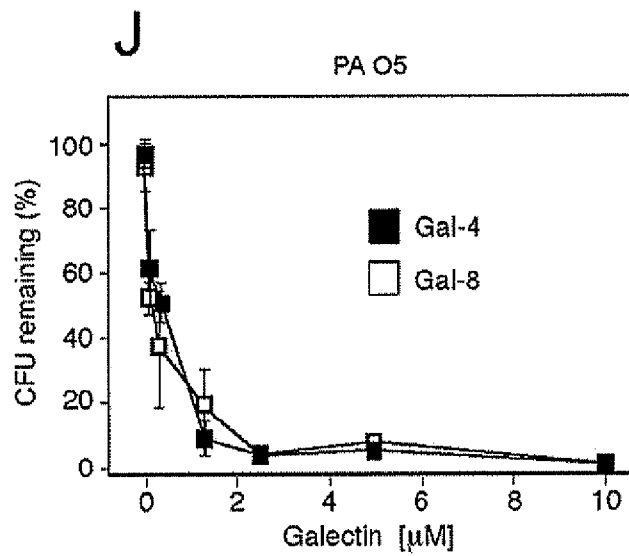

FIGURE 7J

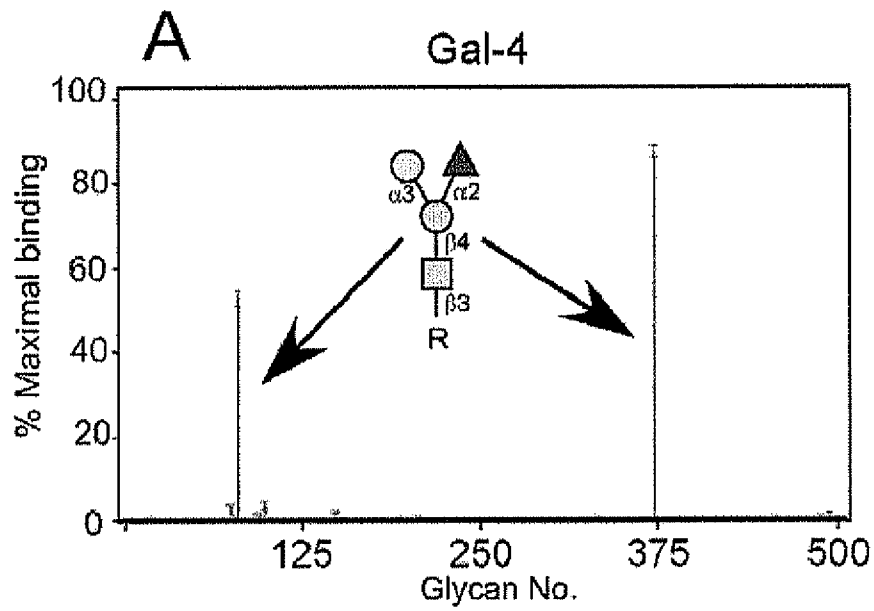

FIGURE 8A

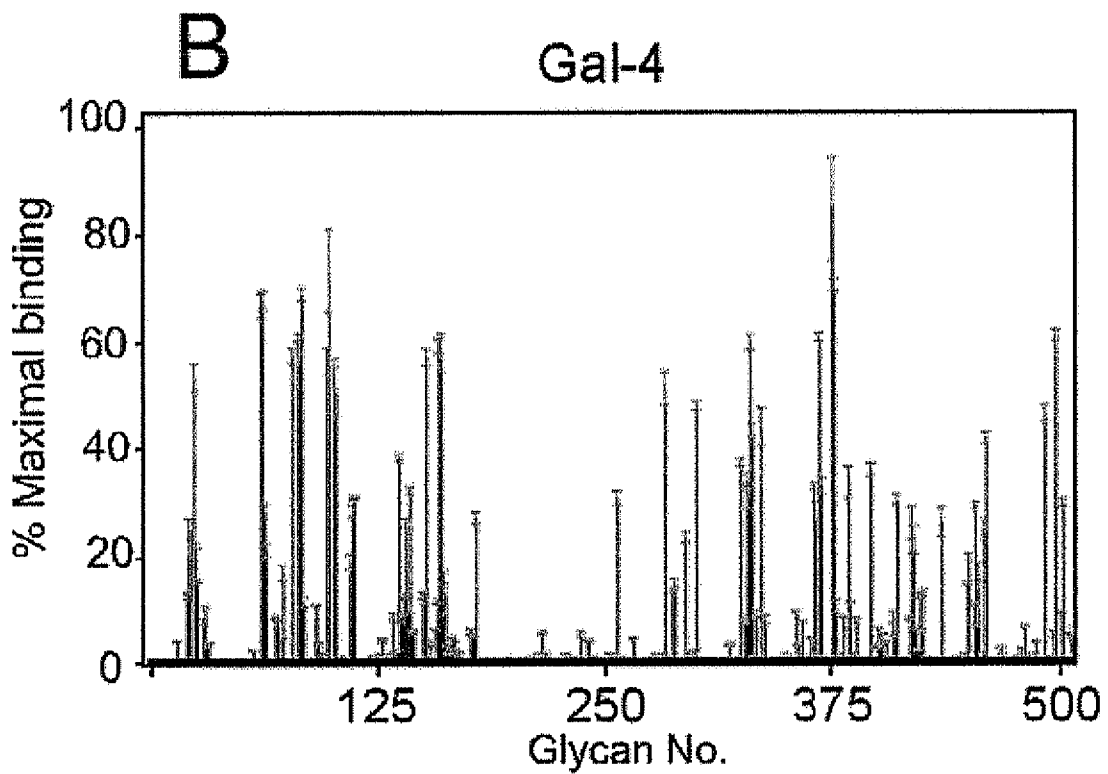

FIGURE 8B

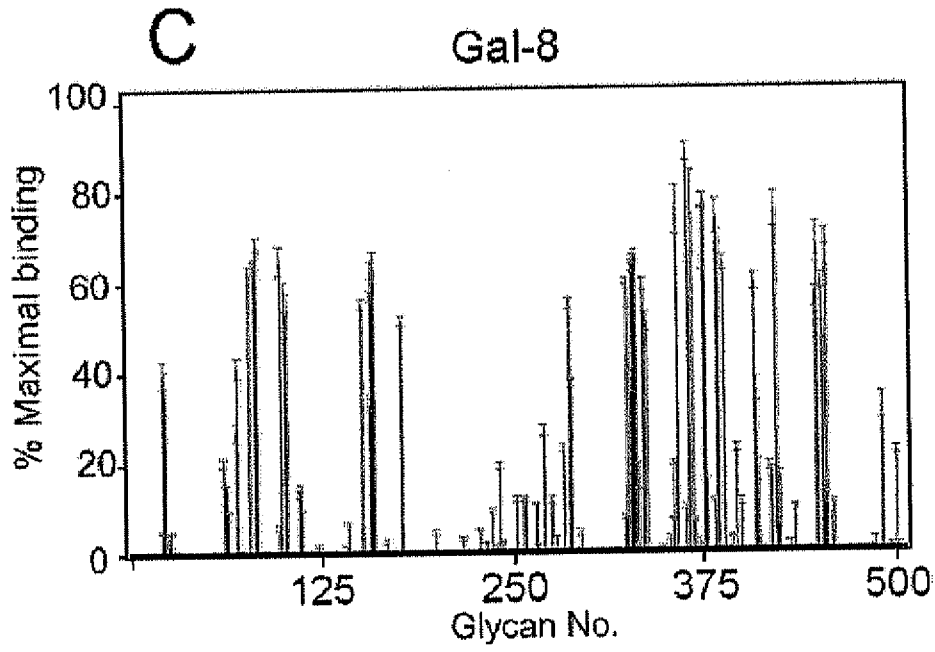

FIGURE 8C

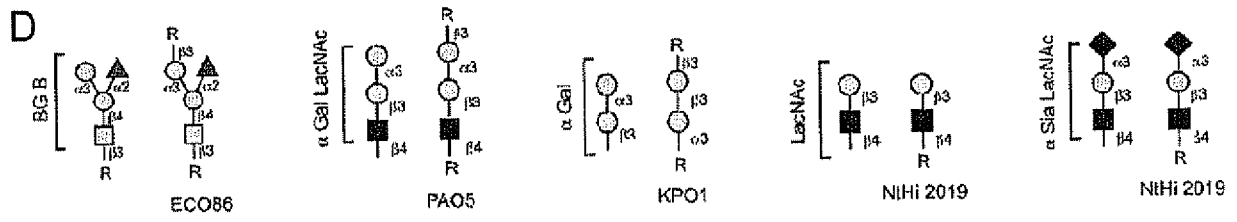

FIGURE 8D

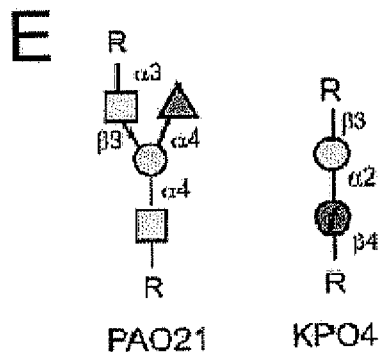

FIGURE 8E

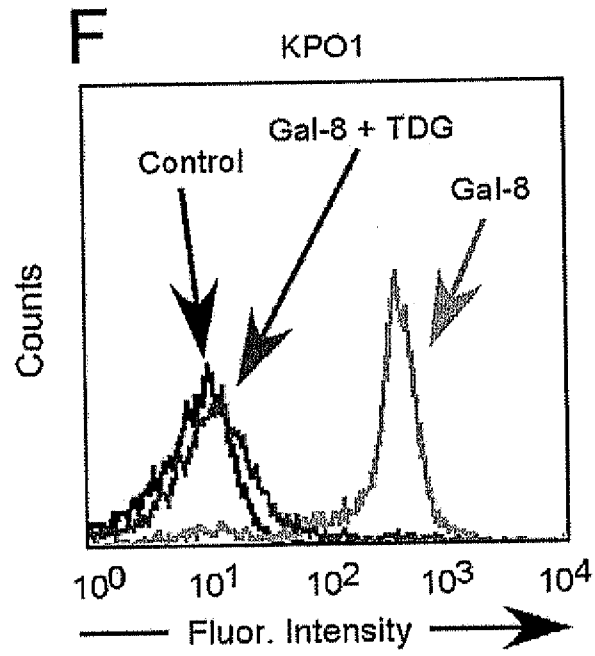

FIGURE 8F

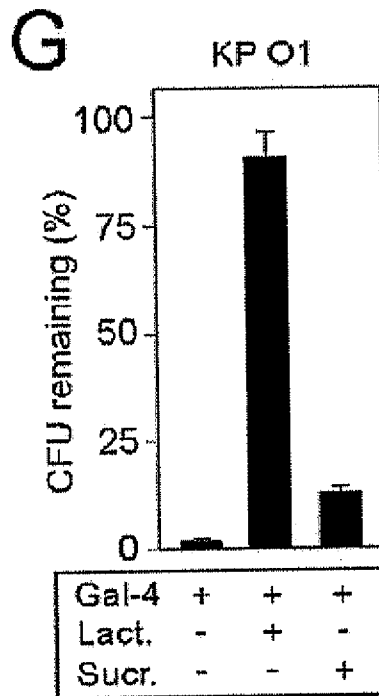

FIGURE 8G

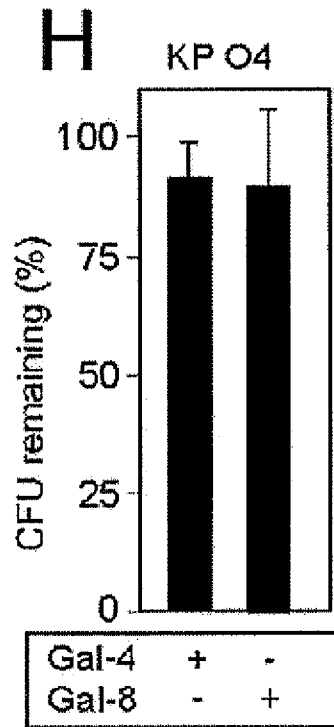

Figure 8H

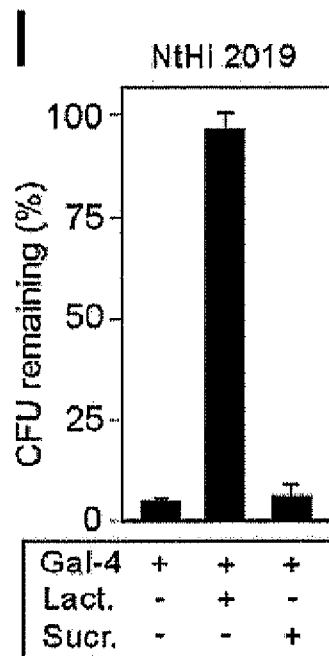

FIGURE 8I

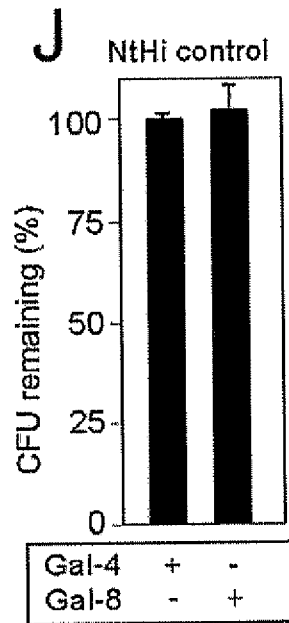

FIGURE 8J

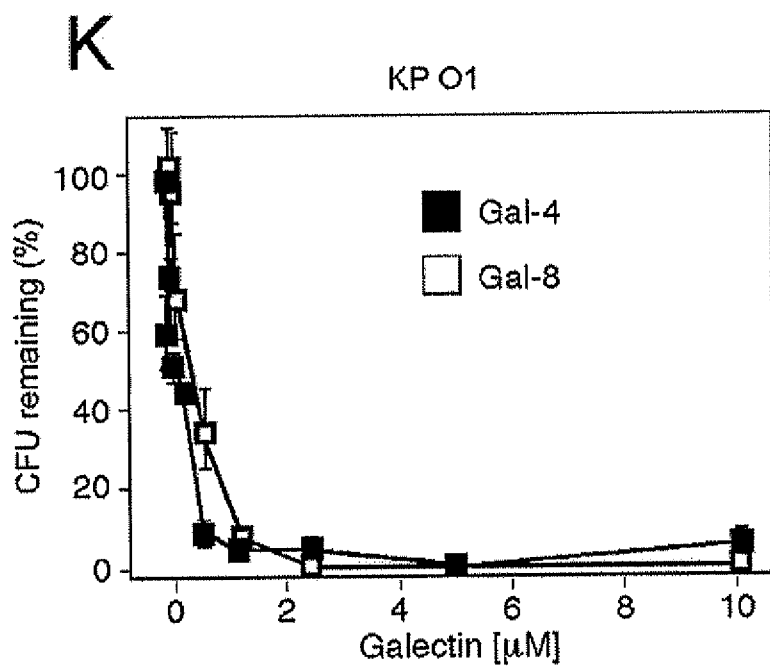

FIGURE 8K

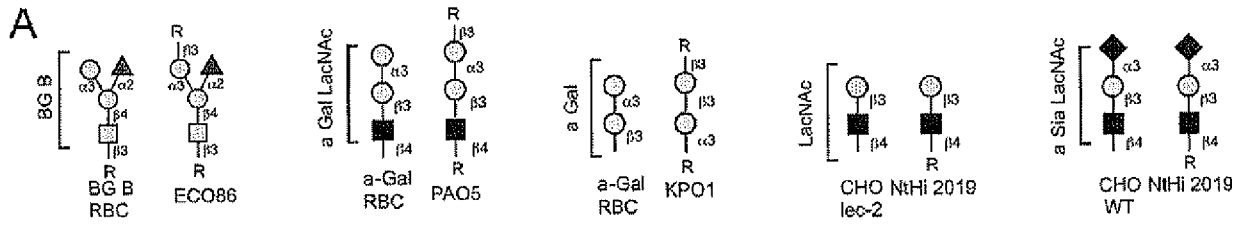

FIGURE 9A

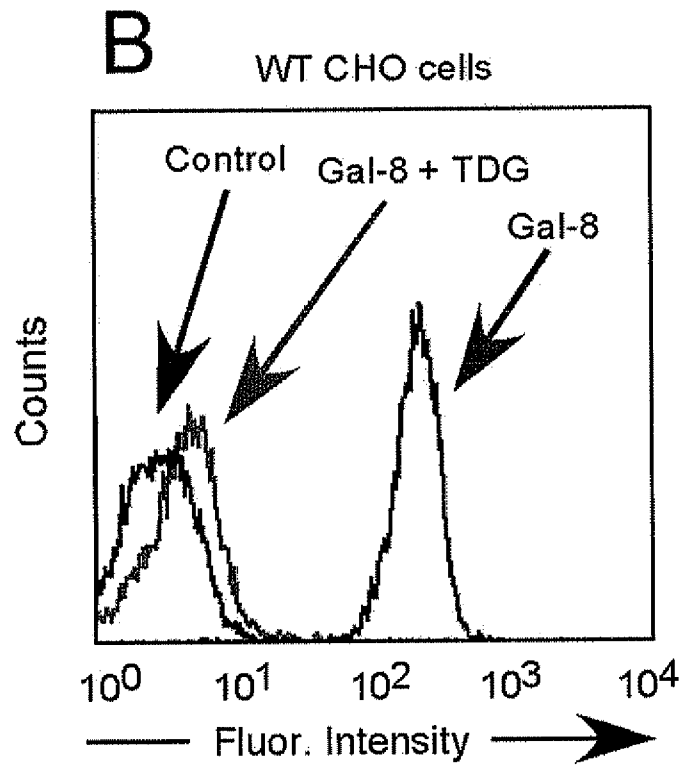

FIGURE 9B

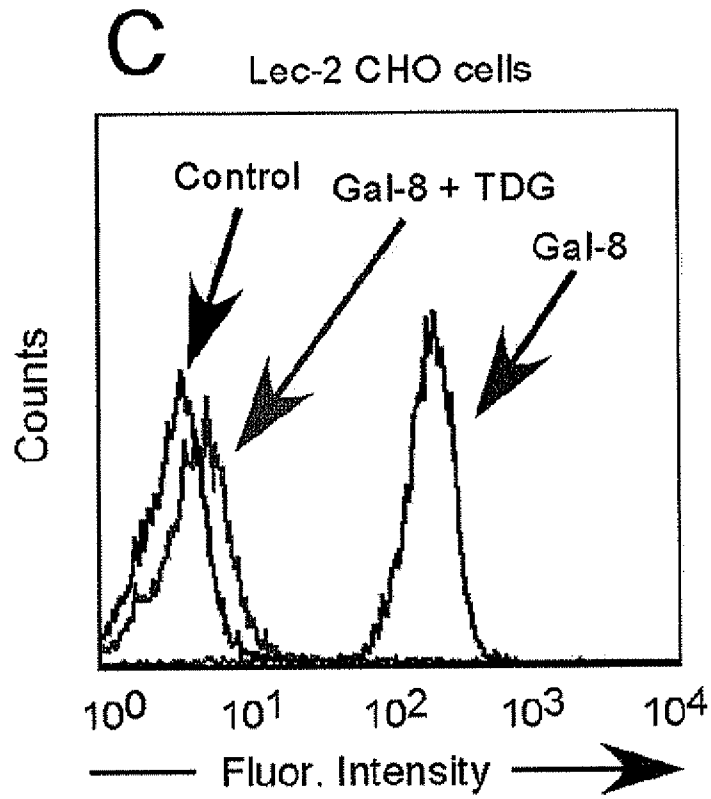

FIGURE 9C

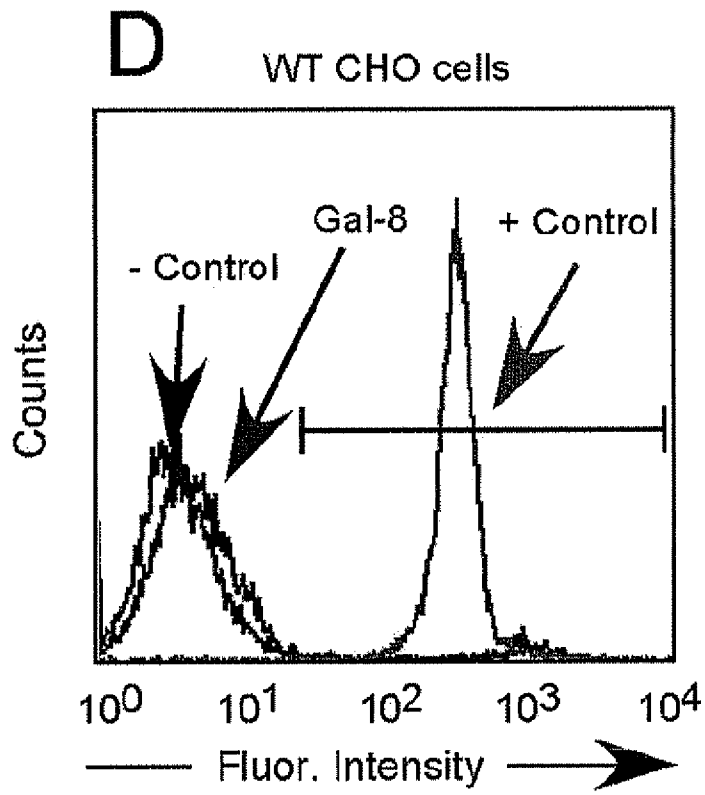

Figure 9D

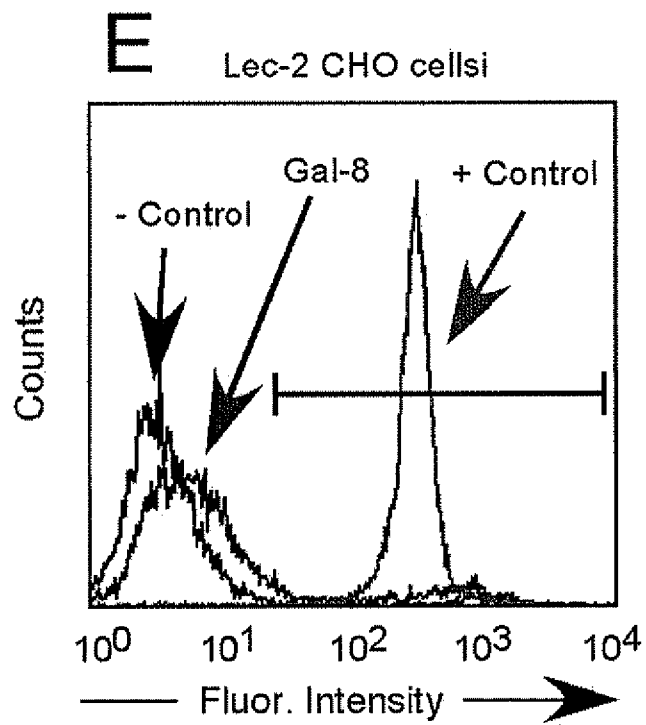

FIGURE 9E

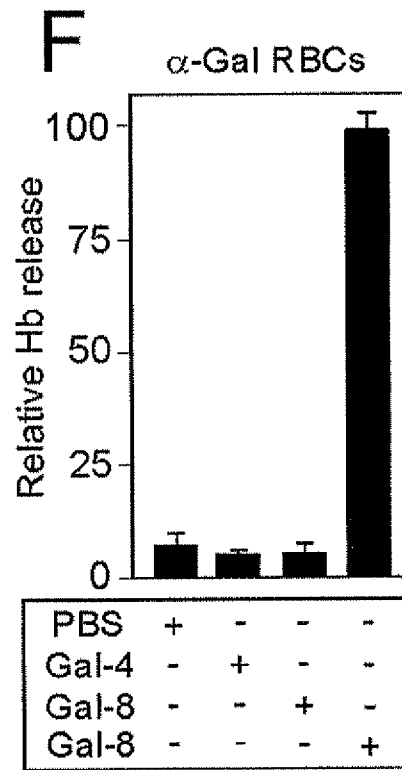

FIGURE 9F



FIGURE 9G

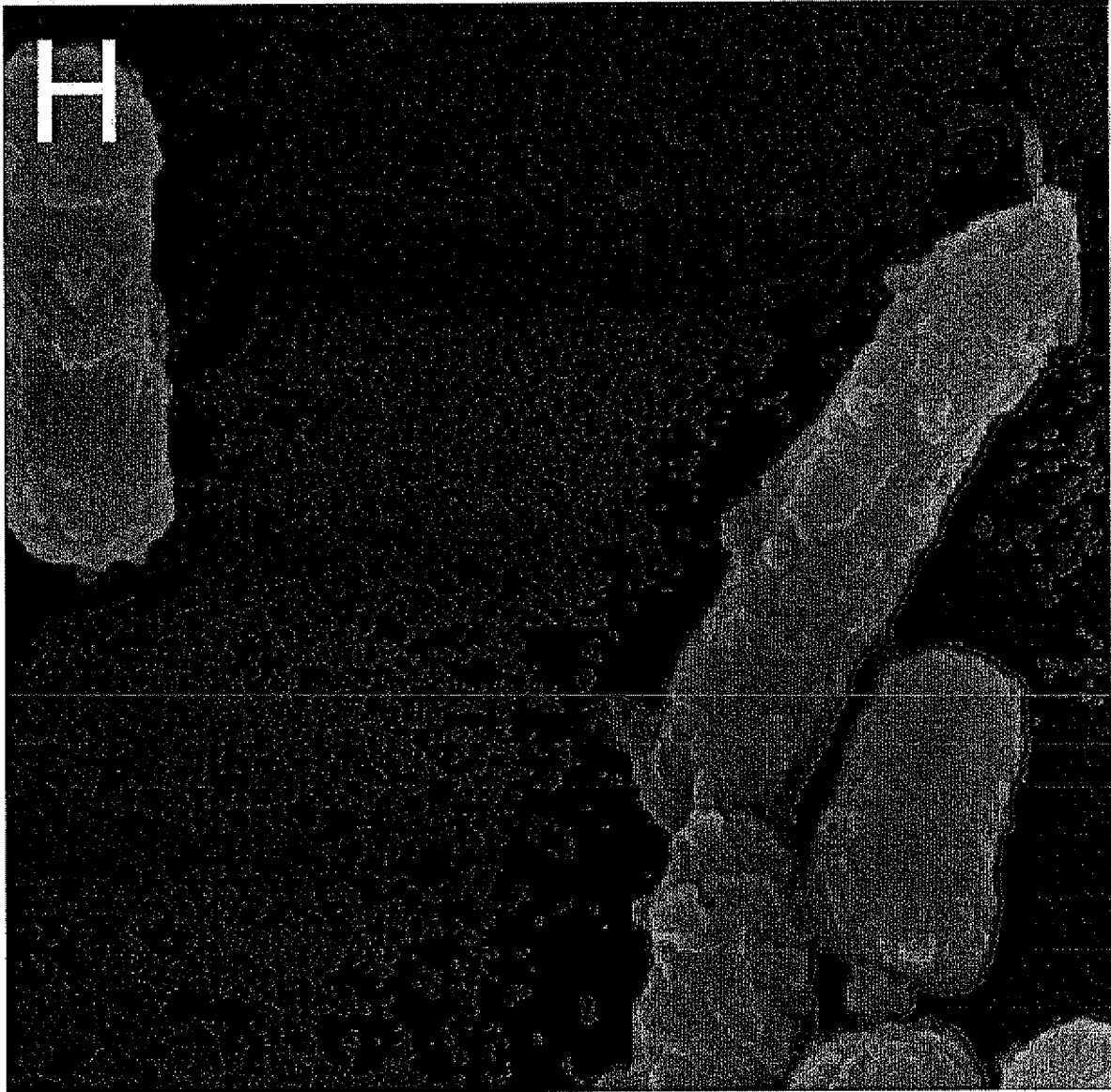

FIGURE 9H

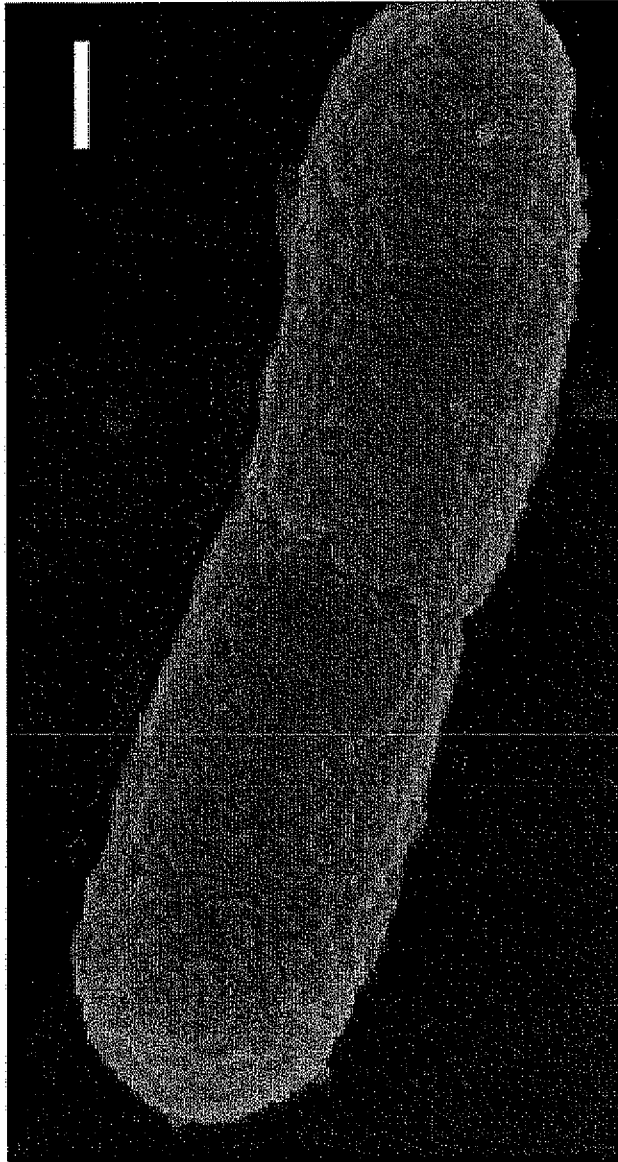

FIGURE 9I

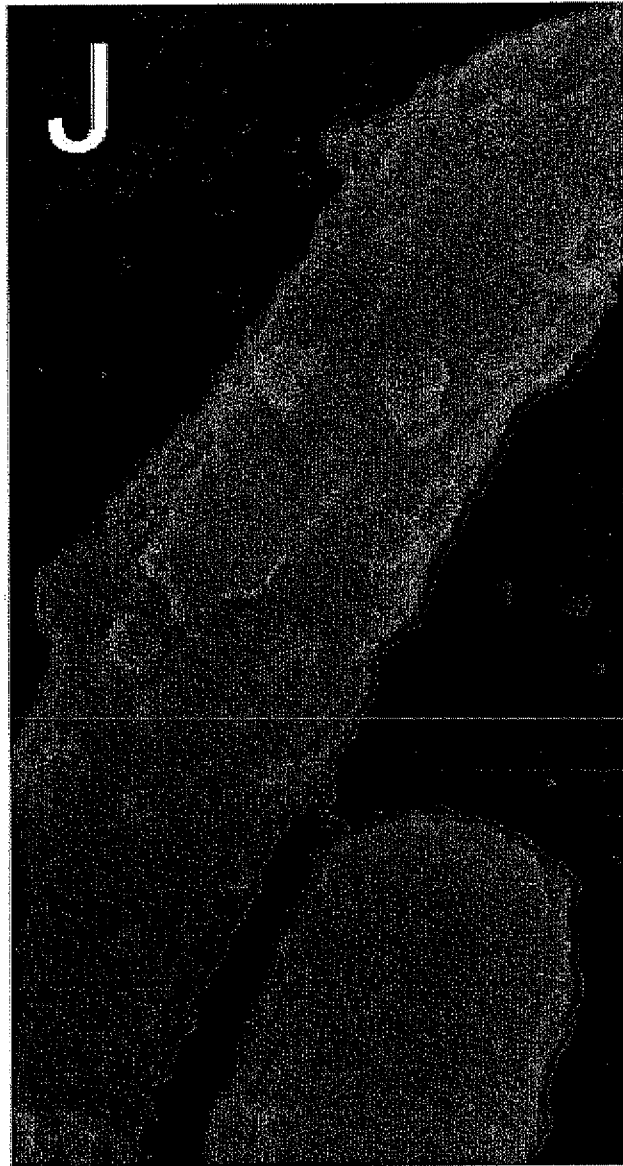

FIGURE 9J