



**FOR THE PURPOSES OF INFORMATION ONLY**

Codes used to identify States party to the PCT on the front pages of pamphlets publishing international applications under the PCT.

AL	Albania	ES	Spain	LS	Lesotho	SI	Slovenia
AM	Armenia	FI	Finland	LT	Lithuania	SK	Slovakia
AT	Austria	FR	France	LU	Luxembourg	SN	Senegal
AU	Australia	GA	Gabon	LV	Latvia	SZ	Swaziland
AZ	Azerbaijan	GB	United Kingdom	MC	Monaco	TD	Chad
BA	Bosnia and Herzegovina	GE	Georgia	MD	Republic of Moldova	TG	Togo
BB	Barbados	GH	Ghana	MG	Madagascar	TJ	Tajikistan
BE	Belgium	GN	Guinea	MK	The former Yugoslav Republic of Macedonia	TM	Turkmenistan
BF	Burkina Faso	GR	Greece	ML	Mali	TR	Turkey
BG	Bulgaria	HU	Hungary	MN	Mongolia	TT	Trinidad and Tobago
BJ	Benin	IE	Ireland	MR	Mauritania	UA	Ukraine
BR	Brazil	IL	Israel	MW	Malawi	UG	Uganda
BY	Belarus	IS	Iceland	MX	Mexico	US	United States of America
CA	Canada	IT	Italy	NE	Niger	UZ	Uzbekistan
CF	Central African Republic	JP	Japan	NL	Netherlands	VN	Viet Nam
CG	Congo	KE	Kenya	NO	Norway	YU	Yugoslavia
CH	Switzerland	KG	Kyrgyzstan	NZ	New Zealand	ZW	Zimbabwe
CI	Côte d'Ivoire	KP	Democratic People's Republic of Korea	PL	Poland		
CM	Cameroon	KR	Republic of Korea	PT	Portugal		
CN	China	KZ	Kazakstan	RO	Romania		
CU	Cuba	LC	Saint Lucia	RU	Russian Federation		
CZ	Czech Republic	LI	Liechtenstein	SD	Sudan		
DE	Germany	LK	Sri Lanka	SE	Sweden		
DK	Denmark	LR	Liberia	SG	Singapore		
EE	Estonia						

**FLAT BOTTOM TOOL****Field of the Invention**

The invention relates generally to a cutting insert to be placed into a tool holder for boring holes into metals. More specifically the invention relates to a cutting tool  
5 insert for boring flat bottomed holes into metals.

**Background of the Invention**

Drilling systems are frequently used to provide cylindrical holes in metallic work pieces. The cutting or boring action of the drill system may be carried out by an elongated, substantially cylindrical drilling tool, such as a combination of a tool holder  
10 and a drill insert which is selectively attached thereto. Such an arrangement may then be used in an application wherein one end of the tool holder is securely mounted in a driving apparatus which rotates the holder about its longitudinal axis. At the opposite end of the elongated tool holder, the cutting insert engages the material to be cut. Alternatively, the workpiece may be made to rotate relative to the holder and cutting insert, such as in  
15 positioning the holder in the tailstock of a lathe or the like. Further, the tool and workpiece may be made to rotate relative to one another. The use of cutting inserts allows for quick changing of the insert upon wear of the cutting surfaces instead of the entire tool, and allows for one tool to be used for a variety of different boring application by simply changing the insert and not the entire drill assembly.

20 For many applications, it may be desirable to form a hole in a work piece which terminates in a flat bottom surface. In general, the drilling system as described above may utilize one type of drill insert for starting such a hole, and then using an insert to produce the desired flat bottom in the hole. Prior cutting inserts that were designed to cut flat bottomed holes have various deficiencies. For example, one type of these inserts had

cutting edges extending from a center portion that were opposingly angled planes, with the center portion being removed in order to accommodate the cutting surfaces to cut a flat bottomed hole. The removal of this center area created a weakened area, point or line where the prior art inserts would occasionally break or fracture. Also, prior art flat bottom hole cutting inserts were designed with an imbalanced geometry causing it to wobble while drilling. This wobble or instability can cause deviations in the dimensions of the hole being bored, also known as runout, which is undesirable. Additionally, prior art drill systems and inserts were configured such that chips from the drilling process were not formed efficiently, causing deterioration of the cutting surfaces. The configuration of the cutting surfaces also did not allow for producing positive rakes in association with chip removal flutes to facilitate chip formation.

### Summary of the Invention

The present invention is directed to a drilling system and drill insert configuration which allows substantially flat bottomed holes to be machined in an improved manner.

The drilling system of the invention comprises a body member having a substantially cylindrical side surface and opposed mounting and cutting ends, and having a longitudinal axis. The body member is configured to be rotationally driven about the longitudinal axis or to have the workpiece rotate or both the body member and workpiece rotate relative to each other. At the cutting end of the body member, there are provided at least first and second cutting surfaces, with the first cutting surface extending radially from a position adjacent the longitudinal or rotational axis of the body to a first outer end. Although in various applications the body member and cutting surfaces are stationary with respect to a rotating workpiece, the axis of the body member and cutting surfaces may be referred to as the rotational axis, which in such an application is the axis about

which the workpiece rotates. The second cutting surface also extends radially from a position adjacent the longitudinal or rotational axis of the body, but in a direction opposite to the first cutting surface and to a second outer end. A web extends between the at least first and second surfaces through the rotational axis of the body to connect the first and second cutting surfaces. In the preferred embodiment, the first and second cutting edges and web form a continuous surface which provides strength and tool stability. Also in the preferred embodiment, the first and second cutting surfaces are oppositely angled downwardly from a cutting edge to a terminating edge, with the web portion extending between the two cutting edges to strengthen the center portion of the flat bottom tool. The height of the cutting edges of each cutting surface remain consistent for formation of a flat bottom hole. In one preferred embodiment, a center point in the bottom surface of the hole is created by increasing the angle of an upwardly extending portion of the cutting edge adjacent the web.

In a further preferred embodiment of the invention, the drilling system comprises a tool holder having a substantially cylindrical side surface and a longitudinal axis, the tool holder having a mounting end and a cutting end. A drill insert having a rotational axis is selectively secured to the cutting end of the holder. The insert is secured in a position such that the rotational or central axis thereof is substantially coincident with the longitudinal axis of the holder. The insert has at least first and second cutting surfaces, the first cutting surface extending radially from a position adjacent the rotational axis of the insert to a first outer end. The second cutting surface extends radially from a position adjacent the rotational axis in a direction opposite the first cutting surface and to a second outer end. A web extends between the at least first and second surfaces through the rotational axis to connect the first and second cutting surfaces.

In both of the above embodiments, stress at the center portion of the tool or insert is further decreased by the cutting surface having a balanced geometry. The balanced geometry of the tool also prevents the tool from wobbling and creating deviations in the hole being formed.

5           The preferred flat bottom tool insert of the present invention may be provided with bores which allow the insert to be attached to a tool holder. The bores may be offset with bores in the holder to allow the insert to be drawn into engagement with a seat provided in the tool holder. Also a slot may be cut into the bottom of the insert to accommodate a positioning member provided in the seat or insert slot of the holder in  
10           order that the insert is seated and positioned properly in the tool holder.

          Flutes may be formed in association with the first and second cutting surfaces for removal of chips of material cut by the cutting edges, the flutes may be formed with a positive rake to facilitate chip formation. Optionally, chip breakers can be cut into the cutting surface edges of the flat bottom tool insert to allow for easier removal of stock  
15           material.

          It is therefore an object of the present invention to provide a drilling system that can cut flat bottomed holes without the deficiencies of the prior art.

          It is a further object of the present invention to provide a drilling system that is balanced so that the tool does not wobble within the hole and therefore create deviations  
20           in the hole being bored.

          It is still a further object of the present invention to provide a drilling system for producing flat bottomed holes that has a positive rake that allows it to more easily form chips of stock material from the hole being bored.

          These and other objects and advantages of the invention as well as the details of

illustrative embodiments, will be more fully understood from the following specification and drawings.

**Brief Description of the Drawings**

Fig. 1 is an exploded view of a drill tool assembly of a preferred embodiment.

5 Fig. 2 is a side view of a first embodiment of a flat bottom drill insert of the present invention without a center point on the cutting surface.

Fig. 3 is a top view of the flat bottom drill insert as shown in Fig. 2.

Fig. 4 is a perspective view from the upper left of the flat bottom insert of Fig. 2.

10 Fig. 5 is a side view of a flat bottom insert according to a further embodiment of the present invention having a center point on the cutting surface.

Fig. 6 is a top view of the flat bottom insert as shown in Fig. 5.

Fig. 7 is a perspective view from the upper left of the flat bottom insert as shown in Fig. 5.

15 Fig. 8 is a side cross-sectional view of the flat bottom insert of the present invention.

**Detailed Description of the Preferred Embodiment**

Reference will now be made in detail to the present preferred embodiments of the present invention, examples of which are illustrated in the accompanying drawings.

Whenever possible, the same reference numbers will be used throughout the drawings to  
5 refer to the same or like parts.

In the present invention, the preferred embodiment of the invention comprises an assembly of parts, but it should be understood that these components could be formed as an integral drilling system. In the preferred embodiment, the drill tool assembly **10** comprises a holder **12**, which has a shank **14** and head portion **16** associated therewith. In  
10 the preferred embodiment, holder **12** has in general a cylindrical shape with a first end **20** and second end **22** with the second end **22** and portion of shank **14** adapted to be fixedly attached in a drilling machine for use. As shown in Fig. 1, the first end **20** of holder **12** has a clamping or holder slot **30** which may extend across the entire diameter of the head portion **16** or at least over a center portion thereof at the general location of the rotational  
15 axis **18** of holder **12**. The holder slot **30** has a bottom wall **32** positioned in substantially perpendicular orientation relative to the rotational axis **18** of the holder **12**. In the preferred embodiment, the assembly **10** may further include a locating boss or dowel pin **24** which is positioned precisely with respect to the axis **18** and extends from the bottom wall **32** of the holder slot **30**. The pin **24** may be positioned within a hole **26** extending  
20 downwardly from the bottom wall **32** of slot **30** along the axis **18** of the holder body in a press fit or other securing relationship to position pin **24**. Alternatively, the locating boss which in the preferred embodiment comprises pin **24**, may be configured in another manner to achieve the corresponding functionality of pin **24**, such as an integral member extending from bottom wall **32**. Within the holder slot **30**, a drill insert **35** is precisely

positioned with respect to the holder 12 to perform the desired drilling function in conjunction therewith. As will be hereinafter described in more detail, the insert 35 has a point geometry comprising a plurality of cutting surfaces which are precisely positioned with respect to the axis 18 of the holder 12, and which form a desired flat bottom hole geometry while minimizing errors in a resulting drilling operation using assembly 10.

More particularly, the preferred embodiment of holder 12 may be configured to include at its first end 20 a pair of clamping arms 34 which extend about holder slot 30. The clamping arms 34 preferably include apertures 36 which accommodate screws 38 to secure the drill insert 35 in its position within the holder slot 30. In the preferred configuration, the holes 36 are threaded to engage screws 38, and mate with screw holes formed in the drill insert 35 in a predetermined manner to precisely locate the drill insert in a predetermined location within holder slot 30. Each of the clamp arms 34 may also include a lubrication vent 28 which allows the application and flow of lubrication adjacent the cutting surfaces of the drill insert to facilitate the drilling operation. The clamp arms 34 may also include angled or curved surfaces which facilitate chip removal via chip evacuating grooves 37 on each side of the holder 12. The seating surface 32 is also shown to be designed as a planar surface which corresponds to the planar bottom portion of the preferred drill insert 35, although another configuration of bottom surface 32 may be employed and is contemplated herein.

Turning to Figs. 2 - 4, a preferred embodiment of the drill insert 35 is shown, and particularly the flat bottom cutting insert of the present invention without a center point is shown. It is reiterated that the insert 35 and associated cutting geometry as will be described, could be formed integrally in the body of holder 12 to form an integrated drilling tool, such an embodiment being contemplated in the invention. The insert 35

may have four sides with the upper side provided with a particular cutting geometry to form flat bottom holes. The cutting geometry is made up of a first surface **56** and a second surface **58**, each having a cutting edge **62** and **64** respectively. Surfaces **56** and **58** and associated cutting edges **62** and **64** are configured to work in conjunction with one  
5 another to form a substantially flat bottomed hole. In possible applications of the drilling system, this type of insert may have a primary use to flat bottom pre-existing holes the same size as the tool. Alternatively, the drilling system may also be used to counter bore smaller size holes when used with shorter length holders. It should be recognized that the drilling system, whether an integral tool or an assembly including holder **12** in  
10 combination with insert **35**, may be provided in any desired diameter or size for a particular application.

The insert **35** may be configured as a plate like body **50** having a thickness a lower side **52** and an upper side **54**. The lower side **52** is seated on surface **32** of holder **12** as previously described. The side edges of the body **50** define the diameter or width of the  
15 hole formed by the drilling assembly. The upper side **54** of the body **50** is provided with at least two surfaces **56** and **58** and associated cutting edges **62** and **64** respectively, which serve to define a cutting geometry to form a flat bottomed hole. Each of the surfaces **56** and **58** extend radially from a position adjacent the center or rotational axis **60** of the insert **35**. When insert **35** is positioned within tool holder **12** as previously described, and  
20 the tool holder **12** is rotated or the workpiece or both will rotate about its longitudinal axis, the insert **35** in conjunction with holder **12** will rotate about axis **60** to effect cutting of a work piece by means of cutting edges **62** and **64**. From the cutting edges **62** and **64**, the surfaces **56** and **58** form clearance surfaces which angle downwardly or away from their respective cutting edge to allow the formation and removal of chips of material

during the cutting process. This angle of back clearance from cutting edges **62** and **64** may be of any suitable value for a particular application, but generally is a somewhat shallow angle to provide clearance without requiring excessive machining or the loss of material strength which would occur from a more severe angle. This back clearance angle is shown at **65** in Fig. 8 for reference. As should be evident from the figures, the respective surfaces **56** and **58** are angled downwardly from their respective cutting edges **62** and **64** in opposite directions to allow each cutting edge **62** and **64** to cut material as the tool and insert **35** rotate relative to the workpiece.

In a cutting geometry of this character, the opposed nature of the surfaces **56** and **58** and associated cutting edges **62** and **64** create a significant problem to the desired formation of a flat bottomed hole. To form a flat bottomed hole, the height of cutting edges **62** and **64** must remain consistent all the way to the center axis **60**. If the cutting edges **62** and **64** continue to the rotational axis **60** of the insert without any variance, the cutting edge height would not remain consistent, and a flat bottom hole would not be produced. If the cutting surface is extended beyond the rotational axis **60**, it should be evident that a portion of the cutting surface would oppose rotation of the insert at the location where the surface extends beyond the rotational axis **60**. In the present invention, this problem is overcome by the formation of a slight upwardly inclined surface in each of the clearance surfaces **56** and **58** at a location immediately adjacent the rotational axis **60**. The upwardly inclined surface associated with each of the cutting surfaces **56** and **58** is generally shown at **66** in Fig. 3, and extends in a plane aligned with the longitudinal axis of insert **35**. In Fig. 2, surface **66** associated with surface **56** is shown, and angle **68** represents the angle of inclination of this surface relative to cutting edge **62** or horizontal. Because clearance surface **56** is angled downwardly from cutting

edge 62 via the back clearance angle previously described, the upward inclination angle 68 of surface 66 is designed to work in conjunction with the back clearance angle such that these angles and the corresponding surfaces meet at approximately rotational axis 60 of insert 35. Also in association with each of the upwardly inclined surfaces 66 is a  
5 cutout portion 69 which works in combination with the back clearance angle 65 and angle of inclination or clearance transition angle 68 to form the desired cutting geometry. The cutout portions 69 remove the sharp corner of the cutting edge at a point adjacent the rotational axis 60 without destroying continuity of the cutting edges to facilitate obtaining the desired flat bottomed hole geometry.

10 To further facilitate forming the desired flat bottom hole geometry, the cutout portion 69 preferably includes first and second surfaces 71 and 73 as shown in Fig. 4. It should be recognized that on the opposed side of the rotational axis is a similar cutout portion although oppositely disposed. Surface 71 extends inwardly from cutting edge 64 to a line of intersection between surfaces 71 and 73 and to a point immediately adjacent to  
15 the formed web 70. Surface 73 then extends outwardly to intersect a portion of rake surface 75 below the height of web 70 so as not to interfere with the cutting action of the other cutting edge 62. The angle 77 as shown in Fig. 4 may be selected to accommodate these features. The angle 77 is chosen as a function of the desired web diameter intersecting the rake face or surface 75 and clearance transition angle 68 such that these  
20 surfaces meet at the same point. Because of the opposed nature of surfaces 56 and 58 and associated cutting edges 62 and 64, this configuration in association with each surface forms the web 70 at the location of the rotational axis 60 of insert 35, thereby forming a continuous surface which engages and forms the flat bottom hole geometries desired.

The web 70 formed by the configuration of the cutting surfaces with respect to

one another provide significant advantage in the tool configuration. The web 70 significantly strengthens the insert at the area of the rotational axis 60, thereby eliminating a weakened zone and possible point of fracture as found in prior art designs. The web 70 further provides that each of the cutting edges 62 and 64 are substantially  
5 continuous to the rotational axis 60 to form a true flat bottom hole geometry rather than having a portion of the hole which is not machined or from which material is removed undesirably. The cutting edge of the insert 35 therefore remains at a consistent height along the entire profile of the cutting edge. This also greatly facilitates stability in use of the drilling system. This characteristic is achieved by the neutral or balanced geometry of  
10 the cutting surfaces, which significantly decrease any tendency of the drilling system to wobble in use.

Another significant benefit of the cutting geometry associated with the drilling system and drill insert according to the present invention is found in the relative ease of manufacture. In the preferred embodiment, the drilling system include insert 35 may be  
15 produced from a simple blank of material with less prefabrication steps therefore necessary in creation of the insert 35. The blank, being the plate-like body forming the insert 35, may then have the cutting surfaces 56 and 58 machined thereon, with only a relatively nominal amount of material removed at notches 69. In the prior art approaches, significantly more material would have to be removed in the cutting surface geometry,  
20 requiring more machining effort, and resulting in an imbalanced cutting geometry which tends to be unstable and wobbles. The cutting geometry of the present invention also facilitates the formation of a positive rake 75 adjacent the cutting edges 62 and 64 to greatly facilitate chip formation from the location adjacent the cutting edges. As shown in Fig. 8, the rake angle 80 is a positive angle which allows a sharp cutting edge to be

formed with significant volume produced in the rake surface **75** for efficient formation of chips in a drilling operation. Further, if desired, each of the surfaces **56** and **58** can be provided with chip breakers **82** to facilitate the reduction and size of and removal of chips created in the drilling process.

5           The cutting geometry also allows a reduction in the diameter of the tool without compromising the effectiveness of the tool. As the diameter of the tool is reduced, the center geometry of the tool remains constant in this region. Therefore, a larger diameter tool may be machined to a reduced diameter conveniently.

Turning now to Figs. 5-7, a similar insert construction is shown, but the cutting  
10 geometry is designed to produce a small center point in the flat bottom hole which is desirable for some applications. Creating a small center point or drill point at the center of the flat bottom hole may facilitate further machining processes desirable in a particular application. The center point in this embodiment also acts to improve the stability and strength of the tool. In the embodiment of Figs. 5-7, many aspects of the drill insert **100**  
15 are similar, and reference to the previous description should be made relative thereto. In this embodiment, the inclination angle **102** of the inclined surface **66** associated with each of the surfaces **56** and **58** is increased. In this manner, the relationship between this inclined surface associated with each of the surfaces **56** and **58** in cooperation with the clearance angle **65** of each of the cutting surfaces (reference Fig. 8) cooperates to again  
20 form a web between the cutting surfaces, but also create a small point substantially along the rotational axis **60** of the insert **100**. This geometry will form a small drill point in the flat bottom hole geometry. By increasing the clearance angle, the direction of the web between the cutting edges **62** and **64** begins to rotate relative to the rotational axis of the insert, but a continuous web is maintained. The diagonal thickness **104** as well as the web

cutting diameter 106 can be modified to some degree by changing the clearance angle and/or angle of inclination of surfaces 66 to strengthen or otherwise to configure the tool as required for various applications.

The flat bottom tool of the present invention can be manufactured from materials  
5 such as high speed steel (HSS), carbide and other materials known in the art to have similar properties of hardness and edge sharpness retention. These base materials can then be coated with hard coating materials such as titanium nitride (TiN), titanium carbonitride (TiCN), and titanium aluminum nitride (TiAlN) to further add hardness and edge retention qualities or other suitable coatings. Various combinations of these or  
10 other suitable base materials and coatings can be used to accommodate numerous applications.

Other embodiments and variations to the preferred embodiments described herein will be apparent to those skilled in the art and may be made without departing from the spirit and scope of the invention as defined in the appended claims.

**What is claimed is:**

1. A drilling system comprising a tool having a longitudinal axis a substantially cylindrical side surface with a mounting end and a cutting end,  
said cutting end having at least first and second cutting edge, said first cutting  
5 edge extending radially from a position adjacent said longitudinal axis to a first outer end, and said second cutting surface extending radially from a position adjacent said longitudinal axis in a direction opposite said first cutting edge to a second outer end, and including a web extending between said at least first and second cutting edges through said longitudinal axis which connects between said first and second cutting edges.
- 10 2. A drilling system comprising,  
a tool holder having a longitudinal axis, said tool holder having a first mounting end and a cutting end,  
a drill insert having a rotational axis, and being selectively secured to said cutting  
end of said holder in a position such that said rotational axis is substantially coincident  
15 with said longitudinal axis of said holder, said insert having at least first and second cutting edges, said first cutting edge extending radially from a position adjacent said rotational axis to a first outer end, and said second cutting edge extending radially from a position adjacent said rotational axis in a direction opposite said first cutting edge to a second outer end, and including a web extending between said at least first and second  
20 cutting edges through said rotational axis which connects said first and cutting edges to form a substantially continuous cutting surface.
3. The drilling system according to claim 2, wherein said first and second cutting edges are formed in association with first and second clearance, said clearance surfaces having a width and each are provided with a cutting edge and a relief edge, wherein said

clearance surface inclines downwardly from said cutting edge toward said relief edge.

4. A drilling system according to claim 3, wherein each of said first and second clearance surfaces further includes an upwardly inclined clearance transition surface adjacent said rotational axis, wherein the angle of inclination of the upwardly inclined clearance transition surface cooperates with the clearance angle of said clearance surface to form said web extending between said first and second cutting edges.
5. The drilling system according to claim 2, wherein said first and second cutting edges have a height, and wherein the height of each of said cutting edges and said web remain substantially consistent to form a flat bottom hole geometry.
- 10 6. The drilling system according to claim 2, wherein each of said cutting edges are formed in association with first and second clearance surfaces having an upwardly inclined clearance transition surface, such that each cutting edge is inclined upwardly at a position adjacent said rotational axis to form an elevated center point between said first and second cutting surfaces.
- 15 7. The drilling system according to claim 2, wherein each of said cutting edges has a portion of the cutting edge removed adjacent said rotational axis of said insert.

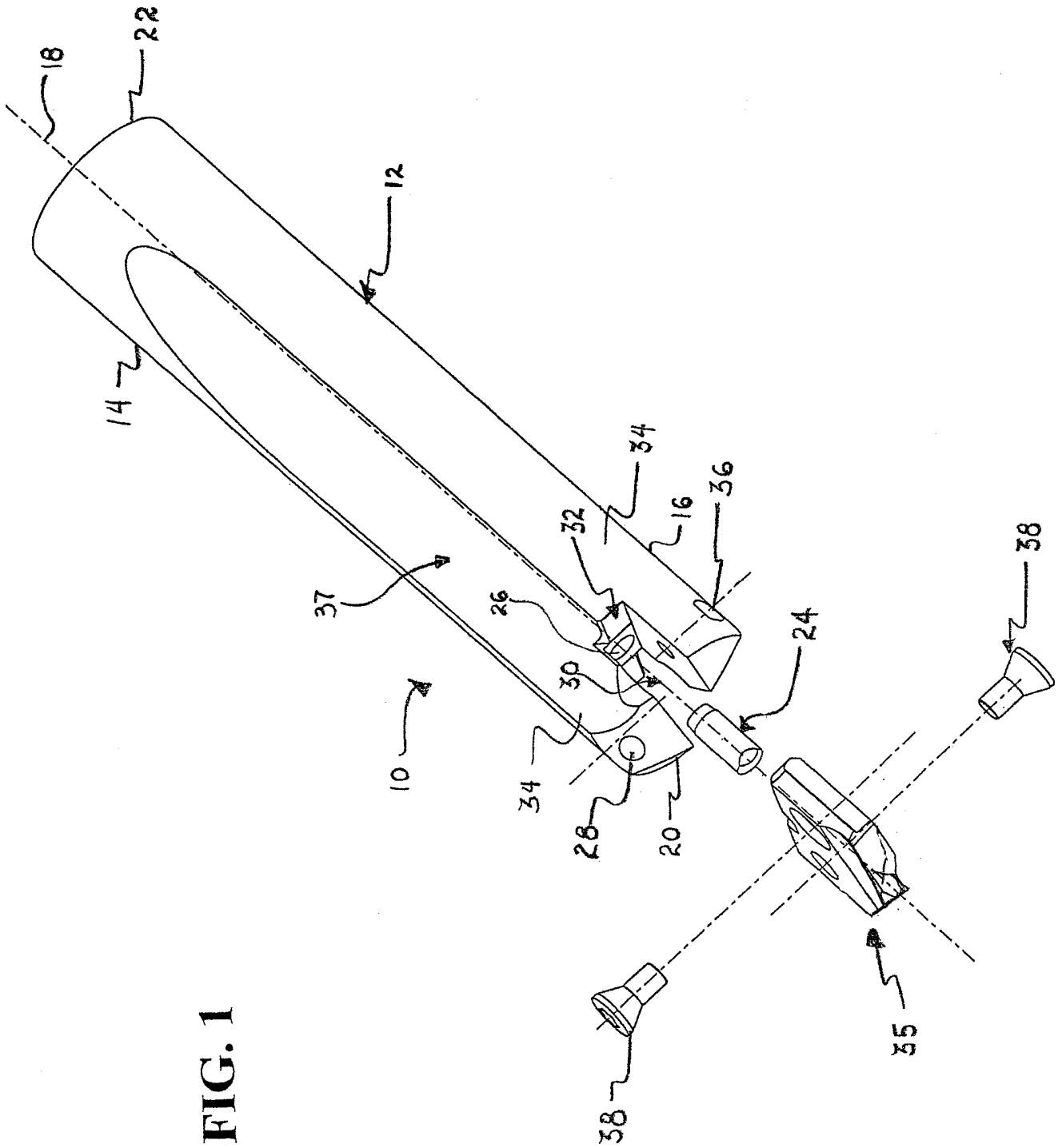

FIG. 1

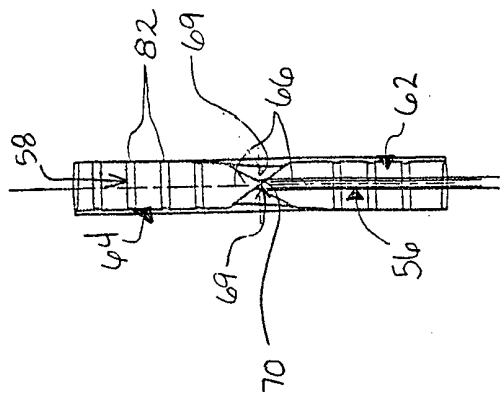

FIG. 3

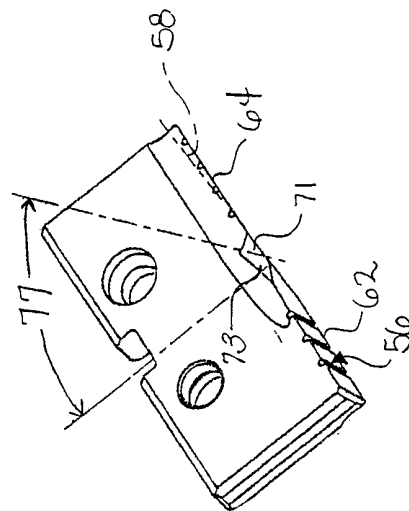

FIG. 4

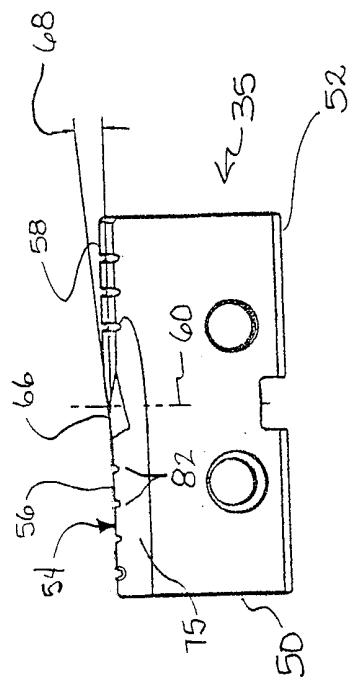

FIG. 2

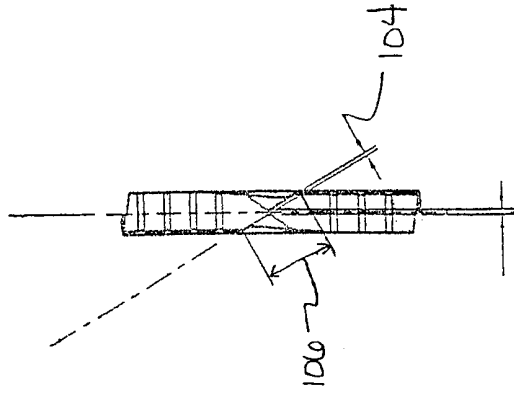

FIG. 6

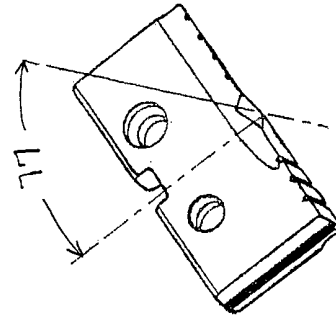

FIG. 7

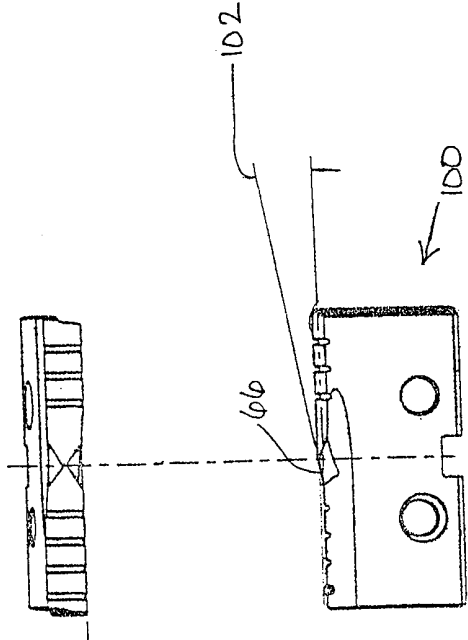

FIG. 5

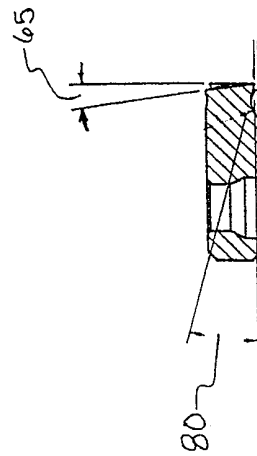

FIG. 8

INTERNATIONAL SEARCH REPORT

International application No.  
PCT/US99/19110

**A. CLASSIFICATION OF SUBJECT MATTER**

IPC(6) :B23B 27/00; B26D 1/12  
US CL :407/54; 408/713

According to International Patent Classification (IPC) or to both national classification and IPC

**B. FIELDS SEARCHED**

Minimum documentation searched (classification system followed by classification symbols)

U.S. : 407/54; 408/713

Documentation searched other than minimum documentation to the extent that such documents are included in the fields searched

Electronic data base consulted during the international search (name of data base and, where practicable, search terms used)

**C. DOCUMENTS CONSIDERED TO BE RELEVANT**

Category*	Citation of document, with indication, where appropriate, of the relevant passages	Relevant to claim No.
X --- Y	US 5,154,549 A (ISOBE et al.) 13 October 1992, entire patent.	1-4, 6, 7 ----- 5
X	US 3,555,964 A (FLEMING) 19 January 1971, entire patent.	1
A	US 5,228,812 A (NOGUCHI et al.) 20 July 1993, entire patent.	1-7
A	US 5,154,550 A (ISOBE et al.) 13 October 1992, entire patent.	1-7
A	US 3,149,534 A (STEPHENS) 22 September 1964, entire patent.	1-7

Further documents are listed in the continuation of Box C.  See patent family annex.

* Special categories of cited documents:	"T"	later document published after the international filing date or priority date and not in conflict with the application but cited to understand the principle or theory underlying the invention
"A" document defining the general state of the art which is not considered to be of particular relevance	"X"	document of particular relevance; the claimed invention cannot be considered novel or cannot be considered to involve an inventive step when the document is taken alone
"E" earlier document published on or after the international filing date	"Y"	document of particular relevance; the claimed invention cannot be considered to involve an inventive step when the document is combined with one or more other such documents, such combination being obvious to a person skilled in the art
"L" document which may throw doubts on priority claim(s) or which is cited to establish the publication date of another citation or other special reason (as specified)	"&"	document member of the same patent family
"O" document referring to an oral disclosure, use, exhibition or other means		
"P" document published prior to the international filing date but later than the priority date claimed		

Date of the actual completion of the international search 29 SEPTEMBER 1999	Date of mailing of the international search report 20 OCT 1999
Name and mailing address of the ISA/US Commissioner of Patents and Trademarks Box PCT Washington, D.C. 20231 Facsimile No. (703) 305-3230	Authorized officer <i>Andie Robinson</i> MONICA SMITH Telephone No. (703) 308-1148