



- (51) International Patent Classification: *F41G 1/38* (2006.01)
- (21) International Application Number: PCT/US2012/066042
- (22) International Filing Date: 20 November 2012 (20.11.2012)
- (25) Filing Language: English
- (26) Publication Language: English
- (30) Priority Data: 61/562,521 22 November 2011 (22.11.2011) US
- (71) Applicant: **LIGHTFORCE USA, INC.** [US/US]; 336 Hazen Lane, Orofino, ID 83544 (US).
- (72) Inventors: **JOHNSON, Klaus**; 7472 Aerie Drive, Lewiston, ID 83501 (US). **RUNIA, Corey**; 42 Four Wheel Drive, Orofino, ID 83544 (US). **STOCKDILL, Kevin**; 13826 4th Avenue, Orofino, ID 83544 (US).
- (74) Agents: **BELLAMY, Glenn, D.** et al.; Wood, Herron & Evans, LLP, 2700 Carew Tower, 441 Vine Street, Cincinnati, OH 45202-2917 (US).
- (81) Designated States (*unless otherwise indicated, for every kind of national protection available*): AE, AG, AL, AM, AO, AT, AU, AZ, BA, BB, BG, BH, BN, BR, BW, BY, BZ, CA, CH, CL, CN, CO, CR, CU, CZ, DE, DK, DM, DO, DZ, EC, EE, EG, ES, FI, GB, GD, GE, GH, GM, GT, HN, HR, HU, ID, IL, IN, IS, JP, KE, KG, KM, KN, KP, KR, KZ, LA, LC, LK, LR, LS, LT, LU, LY, MA, MD, ME, MG, MK, MN, MW, MX, MY, MZ, NA, NG, NI, NO, NZ, OM, PA, PE, PG, PH, PL, PT, QA, RO, RS, RU, RW, SC, SD, SE, SG, SK, SL, SM, ST, SV, SY, TH, TJ, TM, TN, TR, TT, TZ, UA, UG, US, UZ, VC, VN, ZA, ZM, ZW.
- (84) Designated States (*unless otherwise indicated, for every kind of regional protection available*): ARIPO (BW, GH, GM, KE, LR, LS, MW, MZ, NA, RW, SD, SL, SZ, TZ, UG, ZM, ZW), Eurasian (AM, AZ, BY, KG, KZ, RU, TJ, TM), European (AL, AT, BE, BG, CH, CY, CZ, DE, DK,

[Continued on next page]

(54) Title: SCOPE ADJUSTMENT BRAKE

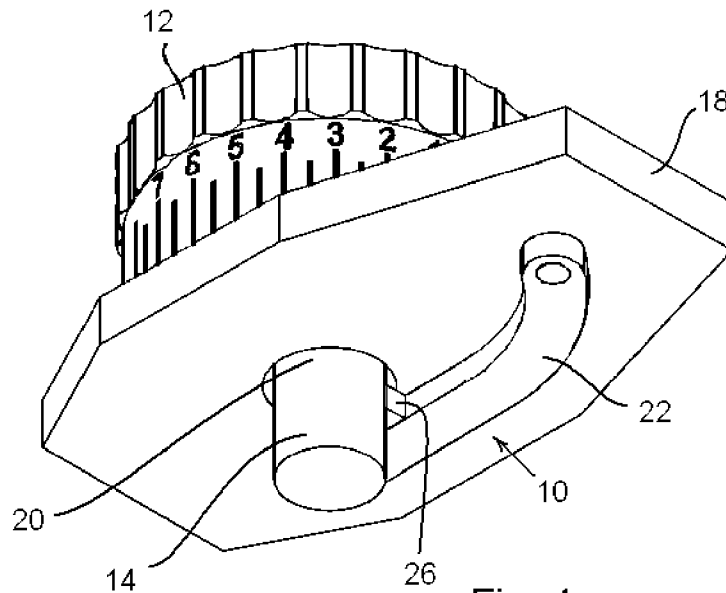

Fig. 4

[Continued on next page]





EE, ES, FI, FR, GB, GR, HR, HU, IE, IS, IT, LT, LU,
LV, MC, MK, MT, NL, NO, PL, PT, RO, RS, SE, SI, SK,
SM, TR), OAPI (BF, BJ, CF, CG, CI, CM, GA, GN, GQ,
GW, ML, MR, NE, SN, TD, TG).

— before the expiration of the time limit for amending the
claims and to be republished in the event of receipt of
amendments (Rule 48.2(h))

Published:

— with international search report (Art. 21(3))

(57) Abstract: In a riflescope (122), a scope adjustment brake (40, 80) for engaging a riflescope's adjustment mechanism (14, 84, 44, 132) includes an engagement portion (26, 56, 96, 140) and an operator-accessible actuator (28, 58, 146) connected to the engagement portion. The engagement portion (26, 56, 96, 140) is moveable between at least a first position in contact with the adjustment mechanism (14, 84, 44, 132) and a second position not in contact with the adjustment mechanism (14, 84, 44, 132).

SCOPE ADJUSTMENT BRAKE

Technical Field

[0001] The invention generally relates to a brake mechanism to selectively prevent unintended adjustment of a riflescope adjustment mechanism.

Background

[0002] Telescopic sighting systems (riflescopes) used to aim a firearm typically include adjustment mechanisms including knobs or dials used for changing the elevation and/or windage setting of a reticle. Typically, an adjustment dial is rotated to cause a lead screw to move axially against an internal optical member, such as an erector tube. In one design, the lead screw is rotated by the adjustment dial as it is moved axially by engaging threads. In another design, the lead screw does not rotate, but is moved axially as a threaded engagement is rotated relative to the lead screw. Once set for a particular range, for example, the elevation adjustment setting preferably remains unchanged until after a shot is fired.

[0003] In riflescopes with exposed adjustment dials, there is a risk that the dial may be inadvertently moved by accidental physical contact. Prior devices have been proposed which mechanically lock the adjustment dial in place, requiring an operator to depress or lift an actuator to release the lock simultaneous with making an adjustment. This can be cumbersome while the operator is wearing gloves or in adverse environments. This also precludes the operator from choosing not to use the locking feature or to deactivate the feature while adjustments are being made and then manually lock the setting when moving from one location to another. Prior devices have also been proposed that lock the adjustment dial at a pre-defined location, requiring an operator to move the adjustment dial to the pre-defined location in order to lock the adjustment dial. This is undesirable to the extent that moving the adjustment dial to the locked position also adjusts the elevation and/or windage setting.

[0004] Thus, a need exists in the field of riflescopes for apparatus for preventing inadvertent adjustments that may be selectively engaged and disengaged by an operator at any point in the range of adjustment and not limited to pre-defined selections.

Summary

[0005] The present invention provides a scope adjustment brake for a riflescope adjustment mechanism mounted on the scope body and movable into frictional braking contact with an adjustment member or adjustable member.

Brief Description of the Drawings

[0006] Like reference numerals are used to indicate like parts throughout the various figures of the drawings, wherein:

[0007] Fig. 1 is a bottom plan view of a scope adjustment brake according to one embodiment of the invention;

[0008] Fig. 2 is a side plan view thereof;

[0009] Fig. 3 is a top plan view thereof;

[0010] Fig. 4 is a bottom isometric view thereof;

[0011] Fig. 5 is a bottom plan view of a scope adjustment brake according to another embodiment of the invention;

[0012] Fig. 6 is a side plan view thereof;

[0013] Fig. 7 is a top plan view thereof;

[0014] Fig. 8 is a bottom isometric view of a scope adjustment brake according to another embodiment of the invention;

[0015] Fig. 9 is a bottom plan view thereof showing the brake in a first position;

[0016] Fig. 10 is a view like Fig. 9 showing the brake in a second position;

[0017] Fig. 11 is a partial upper isometric view of a scope adjustment brake according to still another embodiment of the invention;

[0018] Fig. 12 is a partially cut away top plan view thereof showing the brake in a first position; and

[0019] Fig. 13 is a view like Fig. 12 showing the brake in a second position.

Detailed Description

[0020] Referring to the various figures of the drawing, and first to Figs. 1-4, therein is shown at 10 a scope adjustment brake for a riflescope adjustment mechanism. The scope adjustment brake 10 is shown in the context of an elevation adjustment mechanism, but could also be incorporated into a windage adjustment mechanism. An adjustment dial 12 is provided as part of the elevation adjustment mechanism, and is the type that is rotationally connected to a lead screw 14 that is configured to impinge an internal optical member of the riflescope for adjusting the position of the riflescope's reticle. As the dial 12 is rotated, the lead screw 14 is moved axially by engagement between threads 16 on the lead screw with a threaded member (not shown) that is fixed relative to a scope body.

[0021] The dial 12 is supported on a base 18, and the lead screw 14 extends through a base 18 portion of a scope body. The lead screw 14 includes an engagement portion 20, which may or may not include threads 16 and which may be positioned on the other side of the base 18 from the dial 12. The engagement portion 20 is located along an outer circumferential portion of the lead screw 14.

[0022] An example scope adjustment brake 10 may include an engagement arm 22 and an engagement surface 24, which may be provided by a brake pad 26 connected to the engagement arm 22. The engagement surface 24 and the brake pad 26 are configured to confront and/or contact the circumferential portion of the lead screw 14 having the engagement portion 20. In some embodiments, the brake pad 26 includes an elastomeric friction surface for gripping the engagement portion 20 of the lead screw 14. The engagement arm 22 is connected to an operator-accessible actuator 28 that may be used for selectively engaging and disengaging the scope adjustment brake 10 by frictional contact. As shown in the figures, the engagement arm 22 pivots at 30. The engagement arm 22 is moveable between at least two positions – a first position where its engagement surface 24, including the brake pad 26, is in braking contact with the engagement portion 20 of the lead screw 14, and a second position where its engagement surface 24, including the brake pad 26, is not in braking contact with the engagement portion 20.

[0023] The actuator 28 may be positioned on the same side of the base 18 as the dial 12 and is accessible by an operator. The actuator 28 is connected to the engagement arm 22 and is used to move the engagement arm 22 between the first and second positions. The actuator 28 may be in the form of a switch that is moveable between a "Brake ON" (engaged) orientation and a "Brake OFF" (disengaged) orientation, as shown. The actuator 28 may include structure for keeping it in either the Brake ON or Brake OFF orientations. When the actuator 28 is moved to the Brake ON orientation, the engagement arm 22 is moved toward the lead screw 14, and the engagement surface 24 of the engagement arm 22 bears against the engagement portion 20 of the lead screw 14, putting the engagement arm 22 in the first position. Conversely, when the actuator 28 is moved to the Brake OFF orientation, the engagement arm 22 is moved away from the lead screw 14, putting the engagement arm 22 in the second position.

[0024] When the engagement surface 24 is in braking contact with the engagement portion 20, the lead screw 14 is generally limited in rotation, and the scope adjustment brake 10 limits or prohibits the lead screw 14 from rotation. When in this position the riflescope's adjustment mechanism is limited or prohibited from being adjusted, and the position of the reticle is not disturbed by inadvertent contact with the adjustment dial 12. When the engagement surface 24 is not in contact with the engagement portion, the lead screw 14 is free to rotate and the riflescope's adjustment mechanism may be used to adjust the position of the reticle.

[0025] Referring next to Figs. 5-7, another example scope adjustment brake 40 for a riflescope adjustment mechanism is shown. The scope adjustment brake 40 is shown in the context of an elevation adjustment mechanism, but like scope adjustment brake 10, could also be incorporated into a windage adjustment mechanism. An adjustment dial 42 is provided as part of the elevation adjustment mechanism, and is the type that is connected to a lead screw 44 that is configured to impinge an internal optical member of the riflescope for adjusting the position of the riflescope's reticle. As the dial 42 is rotated, the lead screw 44 is moved axially by a nut (not shown) that engages threads (not shown) on the lead screw 44, but the lead screw 44 does not rotate.

[0026] The dial 42 may be supported on a base 48 with the lead screw 44 extending through the base 48. The lead screw 44 includes an engagement portion 50, which may be positioned on the other side of the base 18 from the dial 12. The engagement portion 50 is located along a flat portion of the lead screw 44.

[0027] The scope adjustment brake 40 includes an engagement arm 52 and an engagement surface 54, which may be provided by a brake pad 56 connected to the engagement arm 52. The engagement surface 54 and the brake pad 56 are configured to engage the flat portion of the lead screw 44 having the engagement portion 50. If desired, the brake pad 56 may include an elastomeric friction surface for gripping the engagement portion 50 of the lead screw 44. The engagement arm 52 is connected to an operator-accessible actuator 58 that may be used for selectively engaging and disengaging the scope adjustment brake 40. As shown in the figures, the engagement arm 52 may be mounted to pivot (at 60). The engagement arm 52 is moveable between at least two positions – a first position where its engagement surface 54, including the brake pad 56, is in braking contact with the engagement portion 50 of the lead screw 44, and a second position where its engagement surface 54, including the brake pad 56, is not in braking contact with the engagement portion 50.

[0028] An actuator 58 may be positioned on the same side of the base 48 as the dial 42 such that it is accessible by an operator. The actuator 58 is connected to the engagement arm 52 and is used to move the engagement arm between the first and second positions. The actuator 58 may be in the form of a switch that is moveable between a “Brake ON” (engaged) orientation and an “Brake OFF” (disengaged) orientation, as shown. The actuator 58 includes structure for keeping it in either the Brake ON or Brake OFF orientations. When the actuator 58 is moved to the Brake ON orientation, the engagement arm 52 is moved toward the lead screw 44, and the engagement surface 54 of the engagement arm 52 bears against the engagement portion 50 of the lead screw 44, putting the engagement arm 52 in the first position. Conversely, when the actuator 58 is moved to the Brake OFF orientation, the engagement arm 52 is moved away from the lead screw 44, putting the engagement arm 52 in the second position.

[0029] When the engagement surface 54 is in braking contact with the engagement portion 50, the lead screw 44 is generally limited in axial movement, and the scope adjustment brake 40 limits or prohibits the lead screw 44 from axial movement. When in this position the riflescope's adjustment mechanism is limited or prohibited from being adjusted, and the position of the reticle is not disturbed. When the engagement surface 54 is not in braking contact with the engagement portion 50, the lead screw 44 is free to move axially and the riflescope's adjustment mechanism may be used to adjust the position of the reticle.

[0030] Referring next to Figs. 8-10, another example scope adjustment brake 80 for a riflescope adjustment mechanism is shown. An adjustment dial 82 is provided as part of the adjustment mechanism and is connected to a lead screw 84 that is configured to impinge an internal optical member of the riflescope for adjusting the position of the riflescope's reticle. The scope adjustment brake 80 may be used for either of the types of adjustment mechanisms discussed above, whether the lead screw 84 rotates or moves axially without rotating, and may be used either with an elevation adjustment mechanism or a windage adjustment mechanism.

[0031] The dial 82 may be supported on a base 88 with the lead screw 84 extending through the base 88. The lead screw 84 includes an engagement portion 90, which may be positioned on the other side of the base 88 from the dial 82. The engagement portion 90 is generally located along an outer circumferential portion of the lead screw 84.

[0032] The scope adjustment brake 80 includes a cam 92, a lever arm 94, a moving engagement linkage 96 having an engagement surface 98, a support linkage 100, and a connector linkage 102. The cam 92 includes a body having two ears extending therefrom, an engagement ear 104 and a disengagement ear 106. The cam 92 engages the lever arm 94 and is connected to an operator-accessible actuator (not shown) that may be used for selectively engaging and disengaging the scope adjustment brake 80. The lever arm 94 is pivotally connected to the connector linkage 102, and is moveable with respect thereto. The lever arm 94 is configured to engage the engagement linkage 96, and may be pivotally connected thereto. The engagement linkage 96 may be

pivotally connected to the base 88, such as at 103, and may include a brake pad 108 for providing the engagement surface 98. The engagement surface 98 and the brake pad 108 are configured to engage (by frictional contact) the circumferential portion of the lead screw 84 having the engagement portion 90. If desired, the brake pad 108 may include an elastomeric friction surface for gripping the engagement portion 90 of the lead screw 84. The support linkage 100 is positioned generally opposite the lead screw 84 from the engagement linkage 96. The connector linkage 102 is connected to the support linkage 100, such as at a pivot 105, and may optionally include a pad 110. The support linkage 100 may be pivotally connected to the base 88, such as at 107.

[0033] The engagement linkage 96 is moveable between at least two positions – a first position where its engagement surface 98, including the brake pad 108, is in braking contact with the engagement portion 90 of the lead screw 84, and a second position where its engagement surface 98, including the brake pad 108, is not in braking contact with the engagement portion 90.

[0034] In particular, the cam 92 is rotatably moveable between at least two positions. In a first position, its engagement ear 104 engages the lever arm 94 to move the lever arm 94 toward the engagement linkage 96 (Fig. 9). In a second position, its disengagement ear 106 engages the lever arm 94 to move the lever arm 94 away from the engagement linkage 96 (Fig. 10).

[0035] When the cam 92 is moved toward its first position, the engagement linkage 96 is pushed toward the lead screw 84 and the engagement surface 98, including its brake pad 108, is in braking contact with the engagement portion 90 of the lead screw 84. In this position, the support linkage 100, including the pad 110, provides support for the lead screw 84. Optionally, the linkage may be configured to move into an “over center” position such that a positive latch is created to hold the engagement surface 98 and brake pad 108 in this braking contact position. Conversely, when the cam 92 is moved toward its second position, the engagement linkage 96 is pulled away from the lead screw 84 and the engagement surface 98, including the brake pad 108, is not in braking contact with the engagement portion 90. The cam 92 may be associated with an operator-accessible actuator, such as a knob for rotating the cam 92 between its first and second positions.

[0036] The support linkage 100 may generally support the lead screw 84 when it is contacted by the engagement linkage 96. This may reduce or eliminate side loading on the lead screw 84 as the engagement linkage 96 presses there against. In addition, the support linkage 100 may provide a "clamping" type of braking contact on the lead screw 84 because it may increase the circumferential portion over which the lead screw 84 is engaged.

[0037] When the engagement surface 98 is in braking contact with the engagement portion 90, the lead screw 84 is generally limited in movement, whether rotation or axial movement, and the scope adjustment brake 80 limits or prohibits the lead screw 84 from moving. When in this position the riflescope's adjustment mechanism is limited or prohibited from being adjusted, and the position of the reticle is not disturbed. When the engagement surface 98 is not in braking contact with the engagement portion, the lead screw 84 is free to rotate or move axially and the riflescope's adjustment mechanism may be used to adjust the position of the reticle.

[0038] Referring next to Figs. 11-13, yet another example scope adjustment brake 120 for a riflescope adjustment mechanism is shown in the context of a partially disassembled riflescope 122. Riflescope 122 includes tube portions 124 and an adjustment mechanism housing, known as the saddle 126. The saddle 126 is for housing the components of the riflescope's adjustment mechanisms, such as those used for changing the elevation and/or windage setting of a reticle. A windage adjustment mechanism bore 128 is shown in the side of the saddle 126 for receiving the windage adjustment mechanism components (not shown). The scope adjustment brake 120 is situated in an opening 130 that houses components of the elevation adjustment mechanism, with a portion of the elevation adjustment mechanism's lead screw shown at 132. The lead screw 132 may be attached to a dial, and is configured to impinge an internal optical member of the riflescope for adjusting the position of the riflescope's reticle. The scope adjustment brake 120 may be used for either of the types of adjustment mechanisms discussed above, whether the lead screw 132 rotates or moves axially without rotating, and may be used either with an elevation adjustment mechanism or a windage adjustment mechanism.

[0039] The scope adjustment brake 120 includes an engagement portion 134 and a support portion 136, the engagement portion 134 and the support portion 136 being positioned on opposite sides of the lead screw 132. The engagement portion 134 includes an engagement surface 138, which may be provided by a brake pad 140 connected to the engagement portion 134. The engagement surface 138 and the brake pad 140 are configured to frictionally contact an engagement portion 142 of the lead screw 132. If desired, the brake pad 140 may include an elastomeric friction surface for gripping the engagement portion 142 of the lead screw 132. The support portion 136 may optionally include an elastomeric pad 144.

[0040] The engagement portion 134 is connected to or associated with an operator-accessible actuator, which in the figures is in the form of a cross-bolt 146. The engagement portion 134 includes a cross-bolt engaging portion 148. A track or slot 150 is defined in the engagement portion 134 for receiving guides 152a, 152b therein, the slot 150 and guides 152a, 152b cooperating to define a generally linear movement path for the engagement portion. The engagement portion 132 further includes arms 154a, 154b extending generally beyond the lead screw 132. The support portion 136 includes arms 156a, 156b, and the engagement portion 134 is connected to the support portion 136 by springs 158a, 158b extending between the arms 154a, 154b and 156a, 156b, respectively.

[0041] The cross-bolt 146 includes a shaft 160 extending between a Brake ON end 162 (to engage the scope adjustment brake 120) and a Brake OFF end 164 (to disengage the scope adjustment brake 120). The shaft 160 extends through a portion of the saddle 126, and the Brake ON end 162 and Brake OFF end 164 may be accessed by an operator. The cross-bolt 146 further includes a notch portion 166 having a first notch portion 168 and a second notch portion 170, which are connected by a ramp 172. The second notch portion 170 is radially inside the first notch portion 168. The cross-bolt 146 is moveable between at least two positions. In a first position, its first notch portion 168 engages the cross-bolt engaging portion 138 of the engagement portion 134 (Fig. 12), and in a second position, its second notch portion 170 also engages the cross-bolt engaging portion 148 (Fig. 13).

[0042] The engagement portion 134 is moveable between at least two positions – a first position where its engagement surface 138, including the brake pad 140, is in braking contact with the engagement portion 142 of the lead screw 132 (Fig. 12), and a second position where its engagement surface 138, including the brake pad 140, is not in braking contact with the engagement portion 142 (Fig. 13). When the cross-bolt 146 is moved toward its first position, such as by an operator pressing on the Brake ON end 162 of the shaft 160, the engagement portion 134 is moved away from the shaft 160 and toward its first position, so its engagement surface 138, including the brake pad 140, bears against the engagement portion 142 of the lead screw 132. When the cross-bolt 146 is moved toward its second position, such as by an operator pressing on the Brake OFF end 164 of the shaft 160, the springs 158a, 158b bias the engagement portion 134 toward the shaft 160 and away from the lead screw 132, and the engagement surface 138 moves out of braking contact with the engagement portion 142 of the lead screw 132.

[0043] The support portion 136 may generally support the lead screw 132 when it is contacted by the engagement portion 134. This may reduce or eliminate side loading on the lead screw 132 as the engagement portion 134 presses there against. In addition, the support portion 136 may provide a "clamping" type of braking contact on the lead screw 132 because it may increase the circumferential portion over which the lead screw 132 is engaged.

[0044] When the engagement surface 138 is in braking contact with the engagement portion 142, the lead screw 132 is generally limited in movement, whether rotation or axial movement, and the scope adjustment brake 120 limits or prohibits the lead screw 132 from moving. When in this position the riflescope's adjustment mechanism is limited or prohibited from being adjusted, and the position of the reticle is not disturbed. When the engagement surface 138 is not in contact with the engagement portion 142, the lead screw 132 is free to rotate or move axially and the riflescope's adjustment mechanism may be used to adjust the position of the reticle.

[0045] In addition, yet another example scope adjustment brake for a riflescope adjustment mechanism is described herein and may be incorporated into an adjustment dial. Most adjustment dials are cylindrical and include an

exterior portion for an operator to grip and rotate or otherwise engage. Rotation of a dial causes adjustment of the elevation and/or windage setting of a reticle, as discussed.

[0046] An interior portion of a dial may provide an engagement surface for limiting the rotation of the dial. Particularly, the interior portion of a dial may resemble a drum having a cylindrical engagement surface. A scope adjustment brake may frictionally engage the cylindrical engagement surface, which may resist or prohibit rotation thereof. The scope adjustment brake may include an engagement portion in the form of a shoe that is moveable between at least two positions – a first position where the shoe is in braking contact with the engagement surface and a second position where the shoe is not in braking contact with the engagement surface. An operator-accessible actuator may be operatively connected to the shoe for moving it between its first and second positions. The actuator may be positioned outside a portion of a scope body for easy access by an operator. Optionally, more than one shoe may be used and the one or more shoes may engage any portion of the engagement surface. When the one or more shoes are in braking contact with the engagement surface, the dial is generally limited in rotation, and the scope adjustment brake limits or prohibits the riflescope adjustment mechanisms from being moved or adjusted.

[0047] While this invention has been described in the context of a riflescope, it will be appreciated that the scope adjustment brakes and other subject matter disclosed herein are equally applicable to other scope applications, such as scopes used with handguns and archery equipment.

[0048] Many features have been listed with particular configurations, options, and embodiments. Any one or more of the features described may be added to or combined with any of the other embodiments or other standard devices to create alternate combinations and embodiments.

[0049] Although the examples given include many specificities, they are intended as illustrative of only one possible embodiment of the invention. Other embodiments and modifications will, no doubt, occur to those skilled in the art. Thus, the examples given should only be interpreted as illustrations of some of

the preferred embodiments of the invention, and the full scope of the invention should be determined by the appended claims and their legal equivalents.

What is claimed is:

1. A brake for a riflescope adjustment mechanism, comprising:
a scope body;
an adjustable member;
an adjustment member configured to cause linear travel of the adjustable member upon rotation of the adjustment member; and
a brake member selectively movable between a first position in braking contact with at least one of the adjustable member and the adjustment member, and a second position out of braking contact.
2. The riflescope adjustment mechanism brake of claim 1, wherein the adjustable member comprises a lead screw and the adjustment member comprises an adjustment dial.
3. The riflescope adjustment mechanism brake of claim 1, wherein the brake member includes a first portion fixed to the scope body and a second portion selectively movable between the first and second positions
4. The riflescope adjustment mechanism brake of claim 1, wherein the adjustable member rotates as it travels linearly, the brake member braking the adjustable member against rotation when in the first position.
5. The riflescope adjustment mechanism brake of claim 1, wherein the adjustable member does not rotate as it traces linearly, the brake member braking against linear movement when in the first position.
6. The riflescope adjustment mechanism brake of claim 1, wherein in the first position, the brake member applies braking force to opposite sides of the adjustable member in a clamping action.
7. The riflescope adjustment mechanism brake of claim 1, wherein the brake member includes an elastomeric material friction surface.

8. The riflescope adjustment mechanism brake of claim 1, wherein the brake member makes braking contact only with the adjustable member.

9. The riflescope adjustment mechanism brake of claim 1, wherein the adjustable member comprises a lead screw.

10. A brake for a riflescope adjustment mechanism, comprising:
a scope body;
an adjustable lead screw configured to be adjustably moved axially in response to rotation of an adjustment dial;
a brake mechanism having a first portion fixed in position relative to the scope body and a second portion selectively movable between a first position in braking contact with the lead screw so as to prevent adjustment movement of the lead screw and a second position not inhibiting adjustment movement of the lead screw.

11. A scope adjustment brake for engaging a lead screw of a scope's adjustment mechanism, the scope adjustment brake comprising:
an engagement portion comprising an engagement surface for contacting an engagement portion on the lead screw; and
an operator-accessible actuator connected to the engagement portion, wherein the engagement portion is moveable between at least a first position in braking contact with the lead screw and a second position not in braking contact with the lead screw.

12. The scope adjustment brake of claim 11, wherein the engagement portion includes a pad defining the engagement surface and wherein the pad is a brake pad that includes an elastomeric friction surface.

13. The scope adjustment brake of claim 11, further comprising a support portion,

wherein the scope adjustment brake is configured so the lead screw is positioned between the engagement portion and the support portion.

14. The scope adjustment brake of claim 11, wherein the actuator comprises a slidable switch.

15. The scope adjustment brake of claim 11, wherein the actuator comprises a rotatable knob.

16. The scope adjustment brake of claim 11, wherein the actuator comprises a cross-bolt member and the cross-bolt moves the engagement portion to its first position and a spring biases the engagement portion toward its second position.

17. The scope adjustment brake of claim 16, wherein the cross-bolt includes a first notch portion and a second notch portion, the first notch portion engaging the engagement portion in the first position and the second notch portion engaging the engagement portion in the second position.

19. The scope adjustment brake of claim 11, further comprising a lever arm connected to the engagement portion and a cam connected to the actuator, the cam engaging the lever arm to move the engagement portion between its first and second positions.

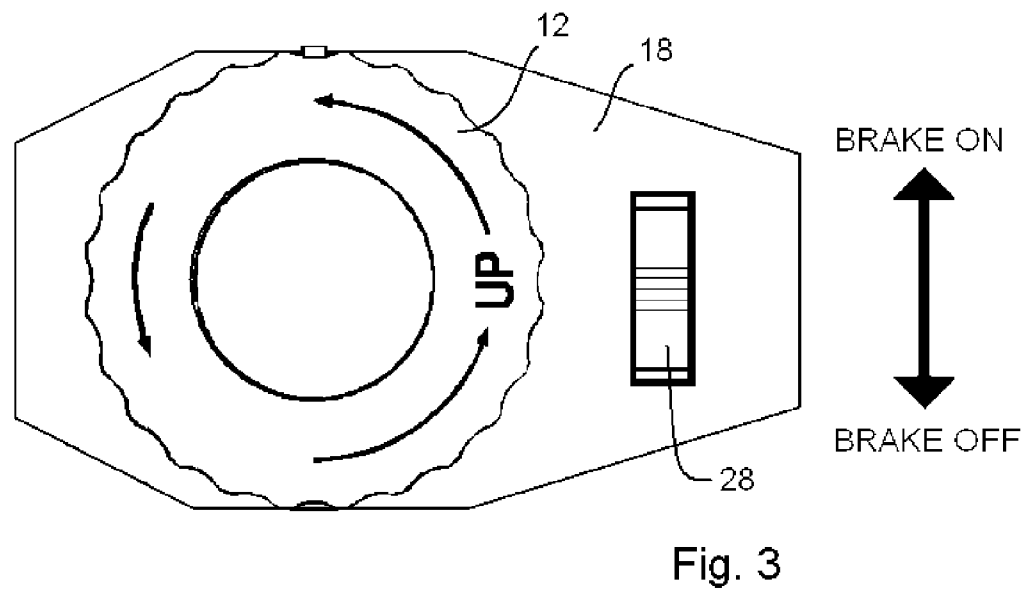
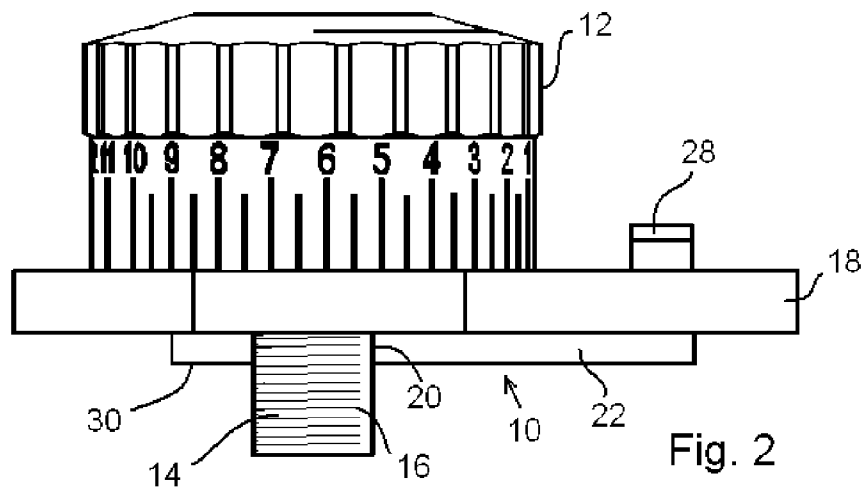
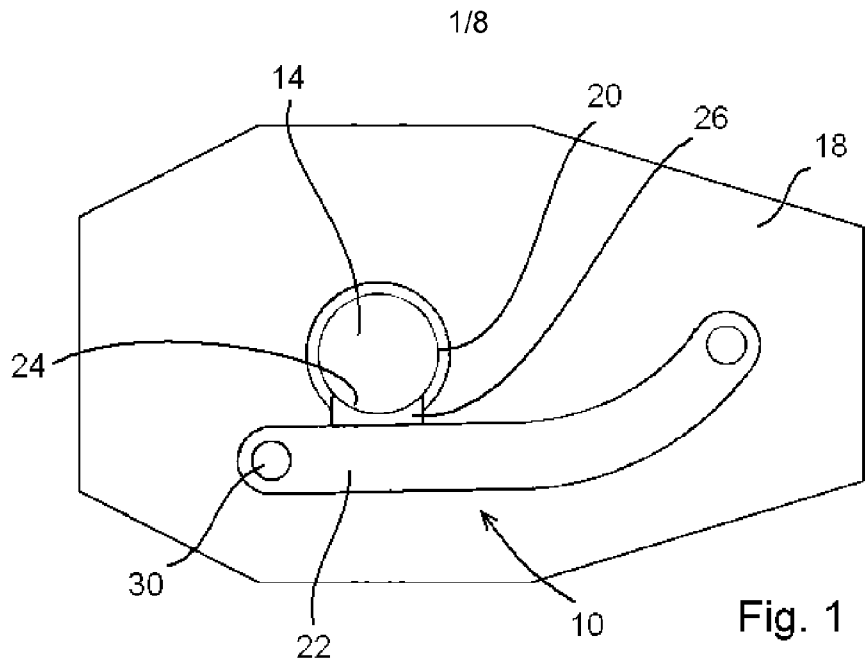

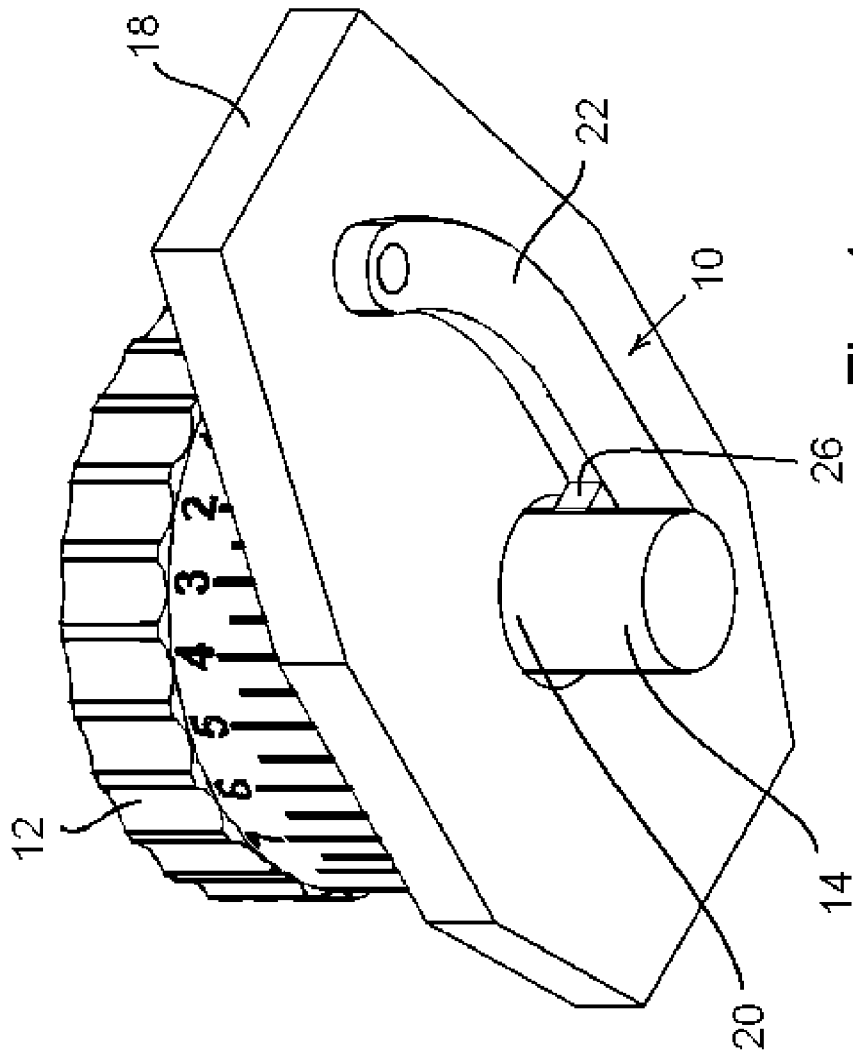
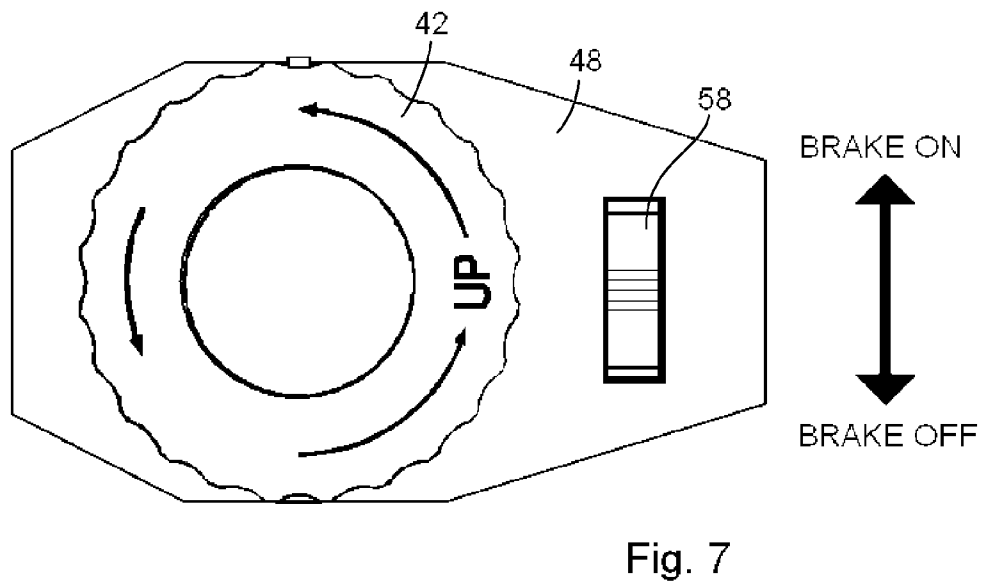
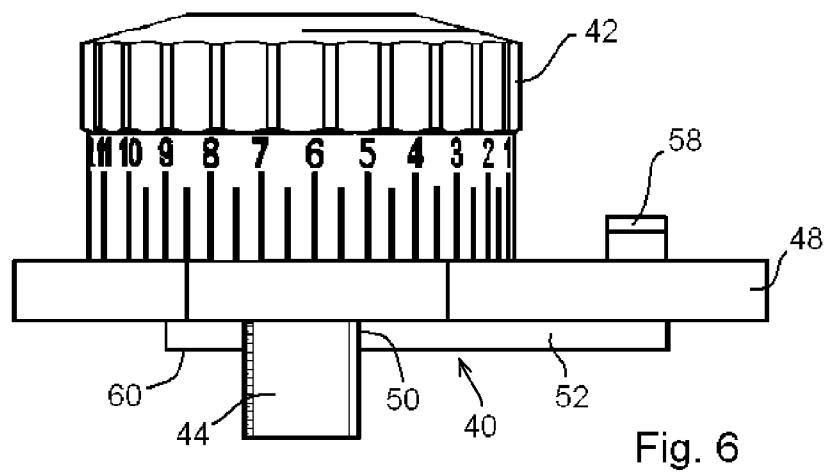
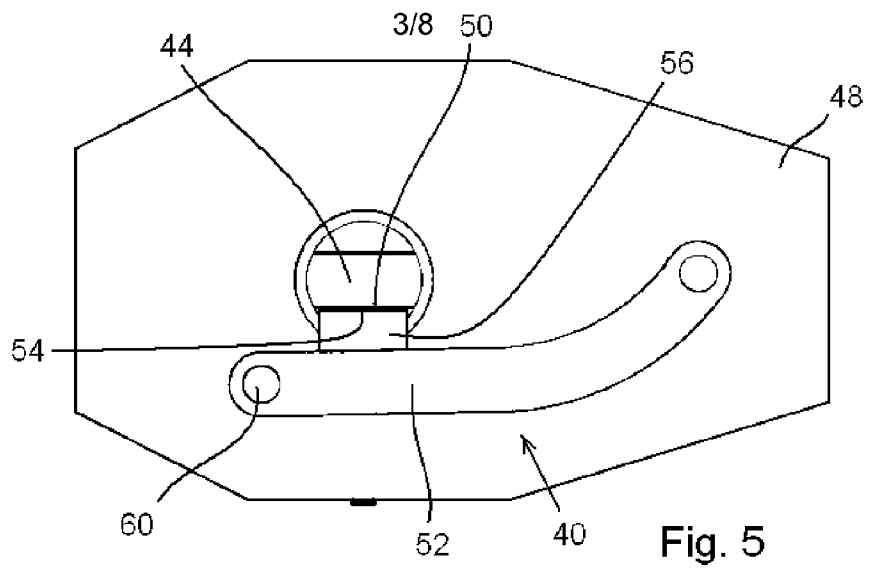

Fig. 4



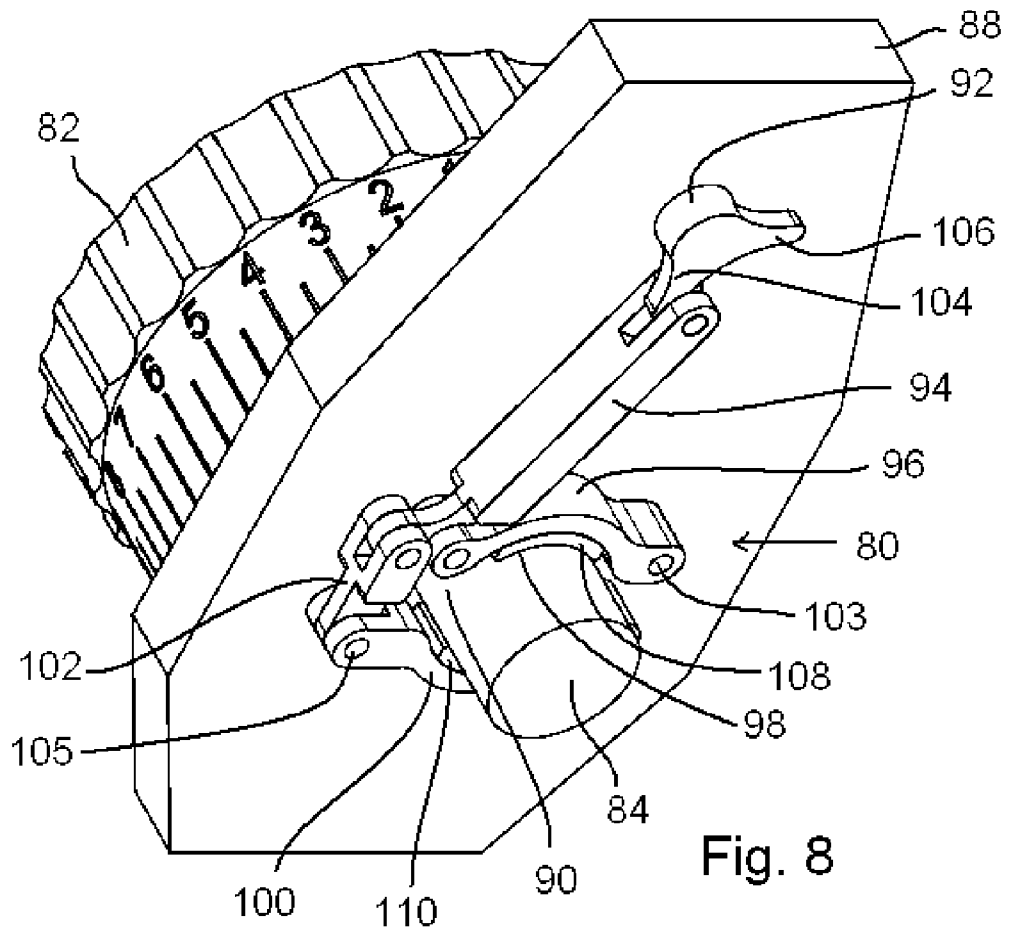

Fig. 8

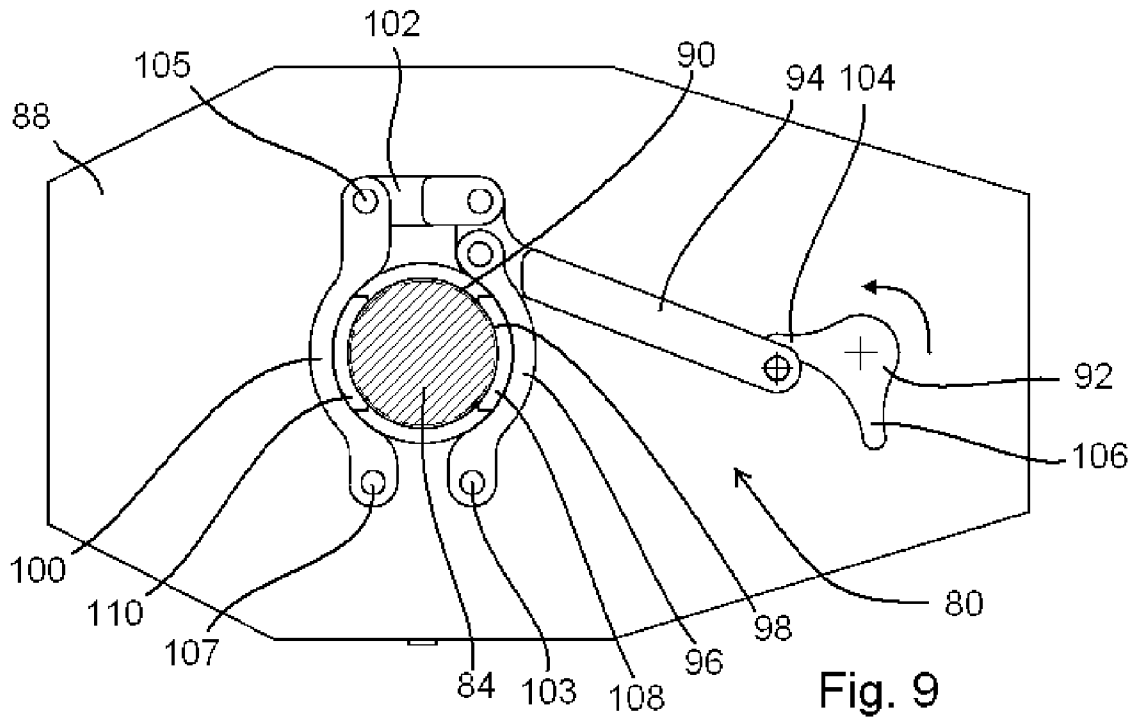

Fig. 9

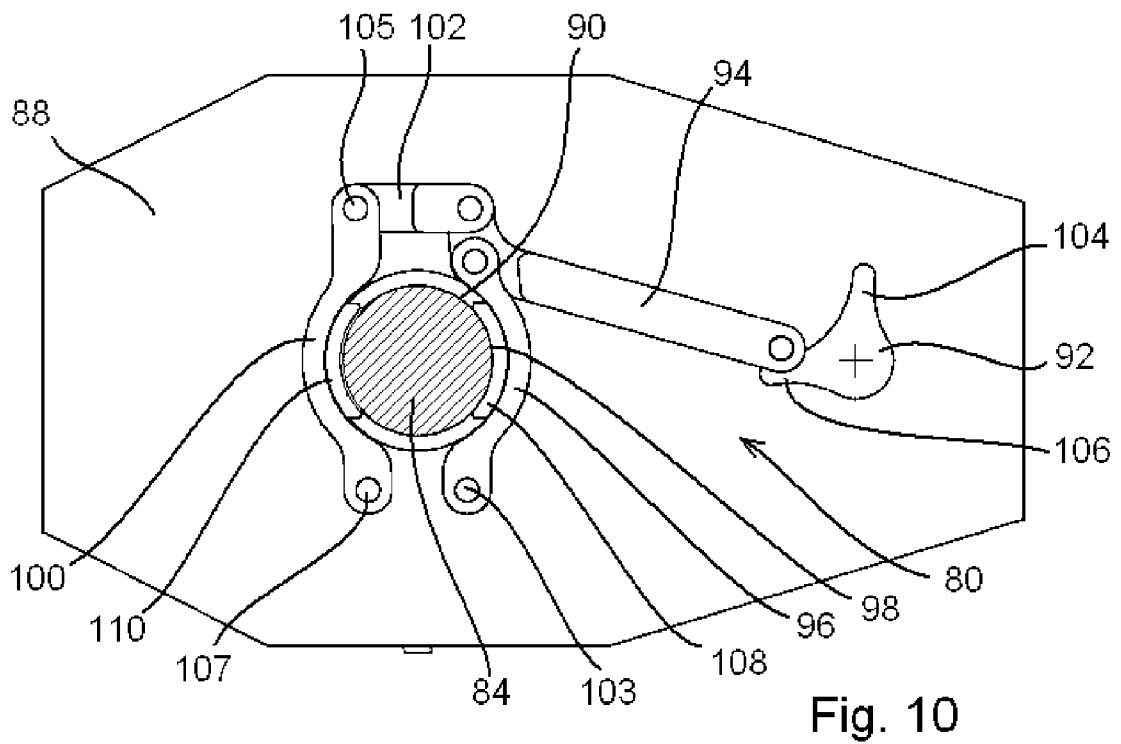

Fig. 10

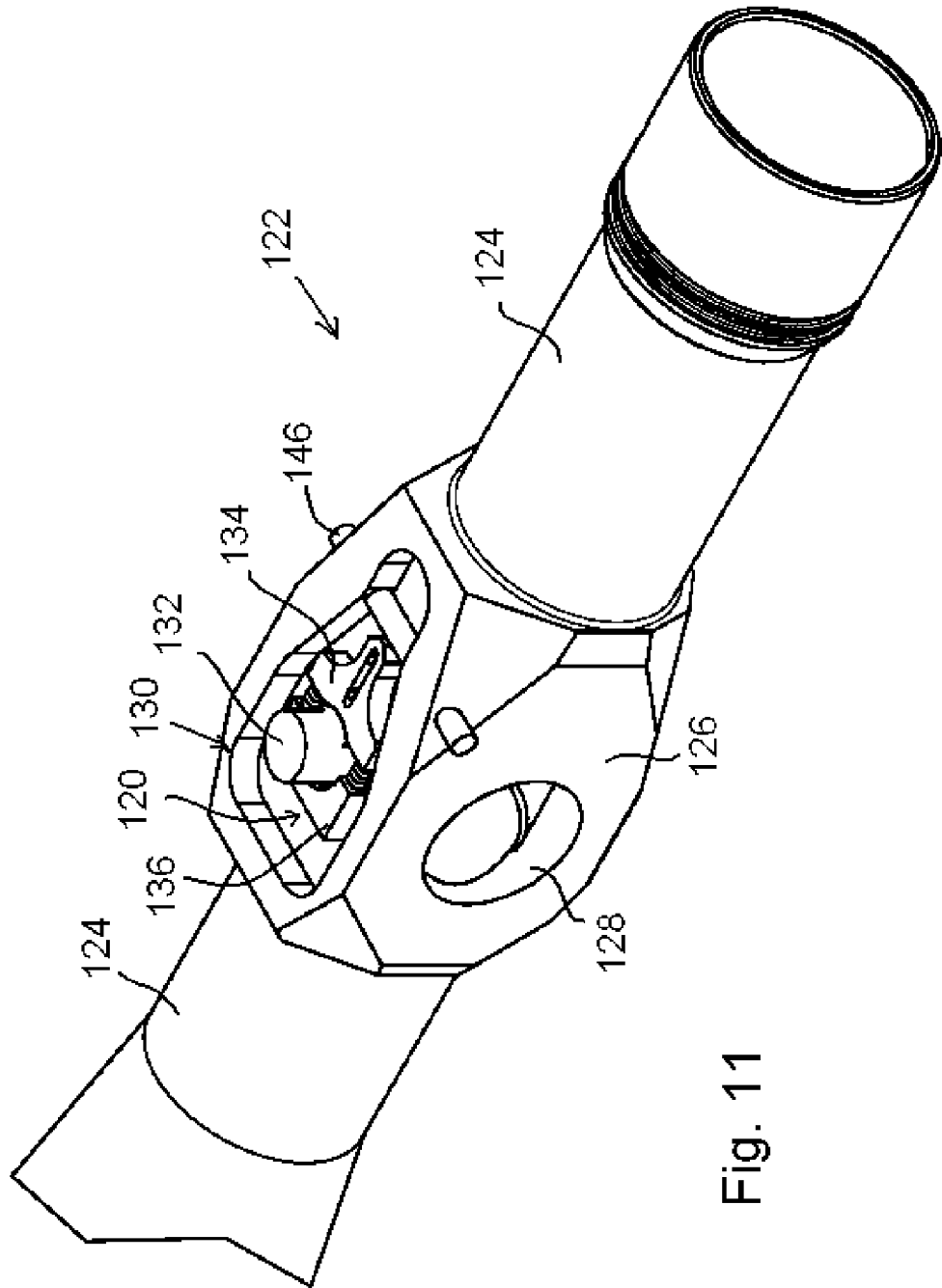

Fig. 11

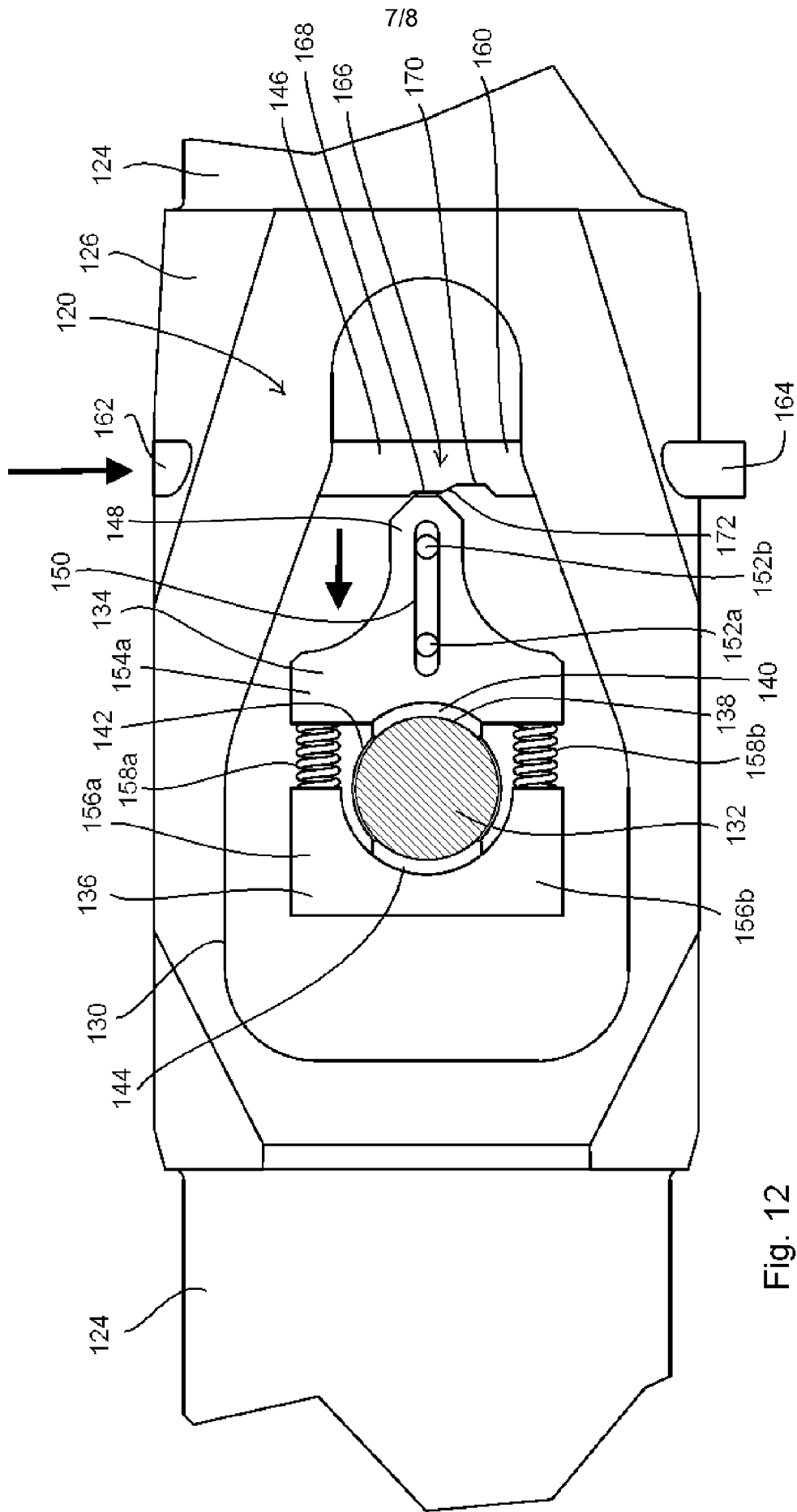

Fig. 12

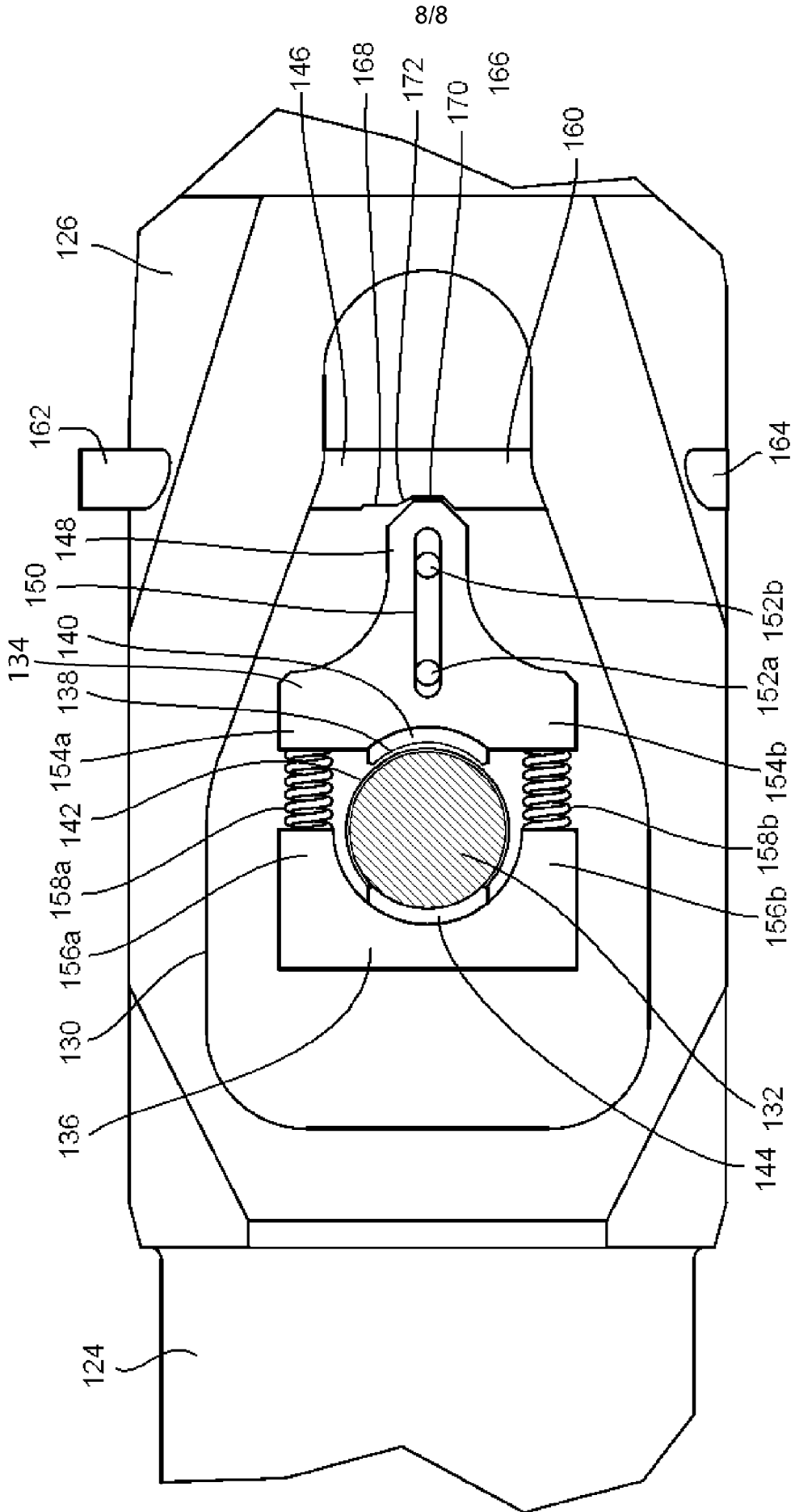

Fig. 13

INTERNATIONAL SEARCH REPORT

International application No.

PCT/US12/66042

<p>A. CLASSIFICATION OF SUBJECT MATTER IPC(8) - F41G 1/38 (2013.01) USPC - 74/813L According to International Patent Classification (IPC) or to both national classification and IPC</p>																							
<p>B. FIELDS SEARCHED</p> <p>Minimum documentation searched (classification system followed by classification symbols) IPC(8): F41G 1/38; G02B 07/00, 7/16, 23/00; F41A 19/18 (2013.01) USPC: 42/119, 122, 125, 129; 74/813L; 89/148</p> <p>Documentation searched other than minimum documentation to the extent that such documents are included in the fields searched</p> <p>Electronic data base consulted during the international search (name of data base and, where practicable, search terms used) MicroPatent (US-G, US-A, EP-A, EP-B, WO, JP-bib, DE-C,B, DE-A, DE-T, DE-U, GB-A, FR-A); DialogPRO; IEEE/IEEExplore; Google/Google Scholar; IP.com; Search Terms Used: Rifle, rifle scope, fire arm, scope, lens, adjust, rotate, turn, brake, stop, lock, unlock, move, position, contact, connect, switch, arm, member, piece, lever, button</p>																							
<p>C. DOCUMENTS CONSIDERED TO BE RELEVANT</p> <table border="1" style="width:100%; border-collapse: collapse;"> <thead> <tr> <th style="width:10%;">Category*</th> <th style="width:70%;">Citation of document, with indication, where appropriate, of the relevant passages</th> <th style="width:20%;">Relevant to claim No.</th> </tr> </thead> <tbody> <tr> <td>X --- Y</td> <td>US 7640830 B2 (BONIS, JG) January 5, 2010, abstract; figure 3; column 1, lines 65-67; column 2, lines 34-39; column 2, 44-46; column 3, lines 5-8; column 3, lines 10-20; column 3, lines 36-51; column 4, lines 1-13</td> <td>1, 8, 11, 13, 15 ----- 2, 4-6, 9, 16, 17, 19</td> </tr> <tr> <td>Y</td> <td>US 2010/0175298 A1 (THOMAS, CR et al.) July 15, 2010, paragraphs [0002], [0023], [0027], [0033], [0034], [0037], [0065]</td> <td>4</td> </tr> <tr> <td>Y</td> <td>US 7543405 B1 (IVEY, S) June 9, 2009, figure 4; column 9, lines 36-37</td> <td>5</td> </tr> <tr> <td>Y</td> <td>US 7886476 B1 (SWAN, RE) February 15, 2011, column 7, lines 15-21</td> <td>6</td> </tr> <tr> <td>Y</td> <td>WO 2010/088624 A1 (HUBER, J) August 5, 2010, abstract</td> <td>2, 9</td> </tr> <tr> <td>Y</td> <td>US 4332407 A (WALDO, RW et al.) June 1, 1982, abstract; column 5, lines 27-35; column 7, lines 10-11; column 7, lines 21-24; column 8, lines 1-6</td> <td>16, 17, 19</td> </tr> </tbody> </table>			Category*	Citation of document, with indication, where appropriate, of the relevant passages	Relevant to claim No.	X --- Y	US 7640830 B2 (BONIS, JG) January 5, 2010, abstract; figure 3; column 1, lines 65-67; column 2, lines 34-39; column 2, 44-46; column 3, lines 5-8; column 3, lines 10-20; column 3, lines 36-51; column 4, lines 1-13	1, 8, 11, 13, 15 ----- 2, 4-6, 9, 16, 17, 19	Y	US 2010/0175298 A1 (THOMAS, CR et al.) July 15, 2010, paragraphs [0002], [0023], [0027], [0033], [0034], [0037], [0065]	4	Y	US 7543405 B1 (IVEY, S) June 9, 2009, figure 4; column 9, lines 36-37	5	Y	US 7886476 B1 (SWAN, RE) February 15, 2011, column 7, lines 15-21	6	Y	WO 2010/088624 A1 (HUBER, J) August 5, 2010, abstract	2, 9	Y	US 4332407 A (WALDO, RW et al.) June 1, 1982, abstract; column 5, lines 27-35; column 7, lines 10-11; column 7, lines 21-24; column 8, lines 1-6	16, 17, 19
Category*	Citation of document, with indication, where appropriate, of the relevant passages	Relevant to claim No.																					
X --- Y	US 7640830 B2 (BONIS, JG) January 5, 2010, abstract; figure 3; column 1, lines 65-67; column 2, lines 34-39; column 2, 44-46; column 3, lines 5-8; column 3, lines 10-20; column 3, lines 36-51; column 4, lines 1-13	1, 8, 11, 13, 15 ----- 2, 4-6, 9, 16, 17, 19																					
Y	US 2010/0175298 A1 (THOMAS, CR et al.) July 15, 2010, paragraphs [0002], [0023], [0027], [0033], [0034], [0037], [0065]	4																					
Y	US 7543405 B1 (IVEY, S) June 9, 2009, figure 4; column 9, lines 36-37	5																					
Y	US 7886476 B1 (SWAN, RE) February 15, 2011, column 7, lines 15-21	6																					
Y	WO 2010/088624 A1 (HUBER, J) August 5, 2010, abstract	2, 9																					
Y	US 4332407 A (WALDO, RW et al.) June 1, 1982, abstract; column 5, lines 27-35; column 7, lines 10-11; column 7, lines 21-24; column 8, lines 1-6	16, 17, 19																					
<p><input type="checkbox"/> Further documents are listed in the continuation of Box C. <input type="checkbox"/></p>																							
<p>* Special categories of cited documents:</p> <table style="width:100%;"> <tr> <td style="width:50%;"> <p>“A” document defining the general state of the art which is not considered to be of particular relevance</p> <p>“E” earlier application or patent but published on or after the international filing date</p> <p>“L” document which may throw doubts on priority claim(s) or which is cited to establish the publication date of another citation or other special reason (as specified)</p> <p>“O” document referring to an oral disclosure, use, exhibition or other means</p> <p>“P” document published prior to the international filing date but later than the priority date claimed</p> </td> <td style="width:50%;"> <p>“T” later document published after the international filing date or priority date and not in conflict with the application but cited to understand the principle or theory underlying the invention</p> <p>“X” document of particular relevance; the claimed invention cannot be considered novel or cannot be considered to involve an inventive step when the document is taken alone</p> <p>“Y” document of particular relevance; the claimed invention cannot be considered to involve an inventive step when the document is combined with one or more other such documents, such combination being obvious to a person skilled in the art</p> <p>“&” document member of the same patent family</p> </td> </tr> </table>			<p>“A” document defining the general state of the art which is not considered to be of particular relevance</p> <p>“E” earlier application or patent but published on or after the international filing date</p> <p>“L” document which may throw doubts on priority claim(s) or which is cited to establish the publication date of another citation or other special reason (as specified)</p> <p>“O” document referring to an oral disclosure, use, exhibition or other means</p> <p>“P” document published prior to the international filing date but later than the priority date claimed</p>	<p>“T” later document published after the international filing date or priority date and not in conflict with the application but cited to understand the principle or theory underlying the invention</p> <p>“X” document of particular relevance; the claimed invention cannot be considered novel or cannot be considered to involve an inventive step when the document is taken alone</p> <p>“Y” document of particular relevance; the claimed invention cannot be considered to involve an inventive step when the document is combined with one or more other such documents, such combination being obvious to a person skilled in the art</p> <p>“&” document member of the same patent family</p>																			
<p>“A” document defining the general state of the art which is not considered to be of particular relevance</p> <p>“E” earlier application or patent but published on or after the international filing date</p> <p>“L” document which may throw doubts on priority claim(s) or which is cited to establish the publication date of another citation or other special reason (as specified)</p> <p>“O” document referring to an oral disclosure, use, exhibition or other means</p> <p>“P” document published prior to the international filing date but later than the priority date claimed</p>	<p>“T” later document published after the international filing date or priority date and not in conflict with the application but cited to understand the principle or theory underlying the invention</p> <p>“X” document of particular relevance; the claimed invention cannot be considered novel or cannot be considered to involve an inventive step when the document is taken alone</p> <p>“Y” document of particular relevance; the claimed invention cannot be considered to involve an inventive step when the document is combined with one or more other such documents, such combination being obvious to a person skilled in the art</p> <p>“&” document member of the same patent family</p>																						
<p>Date of the actual completion of the international search</p> <p>08 March 2013 (08.03.2013)</p>		<p>Date of mailing of the international search report</p> <p align="center">19 MAR 2013</p>																					
<p>Name and mailing address of the ISA/US</p> <p>Mail Stop PCT, Attn: ISA/US, Commissioner for Patents P.O. Box 1450, Alexandria, Virginia 22313-1450 Facsimile No. 571-273-3201</p>		<p>Authorized officer:</p> <p align="center">Shane Thomas</p> <p><small>PCT Helpdesk: 571-272-4300 PCT OSP: 571-272-7774</small></p>																					